

707

AIRPLANE CHARACTERISTICS

AIRPORT PLANNING

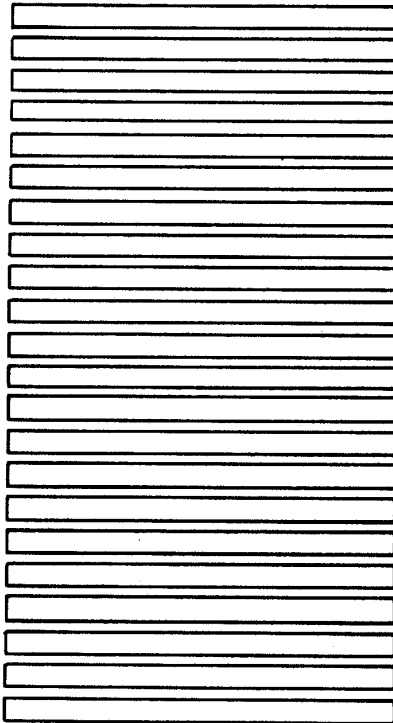

*THE **BOEING** COMPANY
COMMERCIAL AIRPLANE DIVISION*

Not Subject to US Export Administration Regulations (EAR), (15 C.F.R. Parts 730-774)
or US International Traffic in Arms Regulations (ITAR), (22 C.F.R. Parts 120-130).

D6-58322

REVISIONS

707 AIRPLANE CHARACTERISTICS FOR AIRPORT PLANNING

DEC 1968	JUNE 2010	MAY 2011
PAGE	PAGE	PAGE
<hr/> 1-139 <hr/>	<hr/> 113 <hr/>	<hr/> 2 <hr/>
<hr/>	<hr/> 114 <hr/>	<hr/>
<hr/>	<hr/> 140-142 <hr/>	
<hr/>	<hr/>	
<hr/>	<hr/>	
	<hr/>	
	<hr/>	

TABLE OF CONTENTS

SECTION	TITLE	PAGE
1.0	PREFACE	1
1.1	Scope	2
1.2	Introduction	2
1.3	707 Family Comparison	3
2.0	AIRPLANE DESCRIPTION	7
2.1	General Characteristics	8
2.2	General Dimensions	10
2.3	Ground Clearances	13
2.4	Interior Arrangements	16
2.5	Passenger Cabin/Upper Cargo Compartment Cross Sections	19
2.6	Lower Cargo Compartment Capacities	21
2.7	Door Clearances	22
3.0	AIRPLANE PERFORMANCE	29
3.1	Payload/Range for Long Range Cruise	30
3.2	C.A.R. Takeoff Runway Length Requirements	35
3.3	C.A.R. Landing Runway Length Requirements	42
4.0	GROUND MANEUVERING	47
4.1	Turning Radii	48
4.2	Runway and Taxiway Turn Paths	52
4.3	Runway Holding Apron	55
4.4	Minimum Parking Space Requirements	56
5.0	TERMINAL SERVICING	61
5.1	Airplane Servicing Arrangement (Typical)	62
5.2	Terminal Operations, Turnaround Station	64
5.3	Terminal Operations, En Route Station	67

TABLE OF CONTENTS (CONTINUED)

SECTION	TITLE	PAGE
5.4	Ground Service Connections	69
5.5	Engine Starting Pneumatic Requirements	85
5.6	Air Conditioning Requirements	86
5.7	Ground Towing Requirements	90
6.0	JET ENGINE WAKE AND NOISE DATA	93
6.1	Jet Engine Exhaust Velocities and Temperatures	94
6.2	Airport and Community Noise	112
7.0	PAVEMENT DATA	113
7.1	General Information	114
7.2	Landing Gear Footprint	116
7.3	Maximum Pavement Loads	117
7.4	Landing Gear Loading on Pavement	118
7.5	Flexible Pavement Requirements — SEFL 165A	122
7.6	Flexible Pavement Requirements — LCN Conversion	124
7.7	Rigid Pavement Requirements — PCA	128
7.8	Rigid Pavement Requirements — LCN Conversion	133
7.9	Flexible and Rigid Pavement Requirements — FAA Method	137

1.0 PREFACE

1.1 Scope

1.2 Introduction

**1.3 A Brief Description and Comparison of the 707
Family of Airplanes**

1.0 SCOPE AND INTRODUCTION

1.1 SCOPE

This document provides, in a standardized format, airplane characteristics data for general airport planning. Since operational practices vary among airlines, specific data should be coordinated with the using airlines prior to facility design. Boeing Commercial Airplanes should be contacted for any additional information required.

Content of the document reflects the results of the coordinated efforts by representatives from the following organizations:

- Aerospace Industries Association
- Airports Council International – North America
- Air Transport Association of America
- Air Transport Association of America
- International Air Transport Association

1.2 INTRODUCTION

This document conforms to NAS 3601. It provides characteristics of the Boeing Model 707 family of airplanes for airport operators, airlines, and engineering consultant organizations. Airplane changes and available options may alter model characteristics; the data presented herein reflect typical airplanes in each model category.

For additional information contact:

Boeing Commercial Airplanes
P.O. Box 3707
Seattle, WA 98124-2207
U.S.A.

Attention: Manager, Airport Technology
Mail Code: 20-93

1.3 A Brief Description and Comparison of the 707 Family of Airplanes

Model Development

The 707 family of airplanes was derived from the original 707 prototype (Boeing Model 367-80). The original 707-100 Series was developed from the 367-80, and all the other 707 models were derived from the 707-100. Throughout the development of subsequent models, the constant body section (height and width) of the 707-100 was maintained.

Model designations of the 707 family fall into four categories: 707-100 series, 707-200 series, 707-300 series, and 707-400 series. The -100 and -200 series are used on domestic routes. The majority of the -300 and -400 series are used in intercontinental service.

The 707-200 series was developed to meet a specific requirement for an airplane that would be lighter and carry somewhat less payload than the -100. It is essentially the same as the -100 except that it has a different engine and a smaller gross weight.

The 707-300 series was developed to meet the performance requirements for intercontinental service. These airplanes have a longer body, greater wingspan (with high-lift trailing-edge flaps and improved leading-edge flaps), and higher gross weight.

Model Comparison

Model 707-100 and 707-200 series airplanes are represented in this document by the 707-120B. The 707-120 and -220 airplanes originally had non-fan engines (JT3C and JT4A respectively); the majority of the -120's have been modified with JT3D fan engines to yield the 707-120B.

Model 707-300 series airplanes are represented in this document by the 707-320, -320B and -320C. The -320 airplanes have JT4A non-fan engines; the -320B and -320C airplanes have JT3D fan engines.

Model 707-400 series airplanes are represented by the 707-420. The 707-420 is the same as the 707-320 except that it has Rolls-Royce engines rather than Pratt and Whitney engines.

The 707-120, -220, -320, -320B, and -420 are passenger airplanes. The -320C is manufactured in a convertible passenger/cargo version and a strictly freighter version.

The data on the following two pages provide an overall comparison of the members of the 707 family. **Minor dimensional and/or performance differences may exist between some models of the same series as a result of customer option; however, the data presented represent typical airplanes in each model category.**

707 FAMILY COMPARISON

MODEL	ENGINE TYPE	LENGTH		SPAN		BODY		VERTICAL TAIL HEIGHT*	MAXIMUM RAMP WEIGHT (LB)
		OVERALL	FUSELAGE	WING	TAIL	HEIGHT	WIDTH		
707-120B	JT3D	145	138	130	43	14	12	41	258,000
707-220	JT4A	144	→	→	39	→	→	→	248,000
720**	JT3C	136	130	→	→	→	→	41	230,000
720B**	JT3D	136	→	→	43	→	→	41	235,000
707-320	JT4A	152	145	142	45	→	→	42	316,000
707-420	R.Co.-12	→	→	→	→	→	→	→	→
707-320B	JT3D	→	→	145	→	→	→	42	328,000/336,000
707-320C	JT3D	→	→	→	→	→	→	42	336,000

*HEIGHT ABOVE GROUND AT OEW.

**MODELS 720 AND 720B ARE SHOWN HERE FOR INFORMATION BECAUSE THEY ARE DERIVATIVES OF THE 707-100 SERIES.

MODEL	ENGINE TYPE	LENGTH		SPAN		BODY		VERTICAL TAIL HEIGHT* (METERS)	MAXIMUM RAMP WEIGHT KILOGRAMS
		OVERALL (METERS)	FUSELAGE (METERS)	WING (METERS)	TAIL (METERS)	HEIGHT (METERS)	WIDTH (METERS)		
707-120B	JT3D	44.22	42.32	39.88	13.21	4.33	3.76	12.7	117,100
707-220	JT4A	44.20			12.20				112,400
720**	JT3C	41.30	39.78		13.21			12.62	104,400
720B**	JT3D	41.68						12.55	106,700
707-320	JT4A	46.61	44.35	43.40	13.94			12.85	143,500
707-420	R.Co.-12								
707-320B	JT3D			44.42				12.83	148,900/152,500
707-320C	JT3D							12.80	152,500

*HEIGHT ABOVE GROUND AT OEW.

**MODELS 720 AND 720B ARE SHOWN HERE FOR INFORMATION BECAUSE THEY ARE DERIVATIVES OF THE 707-100 SERIES.

707 FAMILY COMPARISON — METRIC

2.0 AIRPLANE DESCRIPTION

2.1 General Characteristics

2.2 General Dimensions

2.3 Ground Clearances

2.4 Interior Arrangements

2.5 Passenger Cabin and Cargo Compartment Cross Sections

2.6 Lower Cargo Compartment Capacities

2.7 Door Clearances

2.0 AIRPLANE DESCRIPTION

2.1 General Characteristics — Model 707

(Definition of terms used on page 9)

Maximum Ramp Weight. Maximum weight authorized for ground maneuver by the applicable government regulations, including taxi and runup fuel. Also designated in some manuals as maximum design taxi weight.

Maximum Landing Weight. Maximum weight authorized at touchdown by the applicable government regulations.

Maximum Takeoff Weight. Maximum weight authorized at takeoff brake release by the applicable government regulations and excludes taxi and runup fuel.

Operating Empty Weight. Weight of structure, power plant, furnishings, systems, unusable fuel and other unusable propulsion agents, and other items of equipment that are considered an integral part of a particular aircraft configuration. Also included are certain standard items, personnel, equipment, and supplies necessary for full operation, excluding fuel and payload.

Zero Fuel Weight. Maximum airplane weight less usable fuel, engine injection fluid, and other consumable propulsion agents. It may include usable fuel in specified tanks when carried in lieu of payload. The addition of usable and consumable items to the Zero Fuel Weight must be in accordance with the applicable government regulations so that airplane structure and airworthiness requirements are not exceeded.

Maximum Structural Payload. Consists of the maximum design payload weight of passengers, passenger baggage and/or cargo.

Maximum Seating Capacity. The maximum number of passengers specifically certified or anticipated for certification.

Maximum Cargo Volume. The maximum space available for cargo.

Usable Fuel Capacity. The volume of fuel carried for a particular operation less drainable unusable fuel and trapped fuel remaining after a fuel runout test has been accomplished.

AIRPLANE CHARACTERISTIC	UNIT OF MEASURE	MODEL					
		-120B	-320/-420	-320B		-320C	
				PASSENGER	CARGO	PASSENGER	FREIGHTER
MAXIMUM RAMP WEIGHT	POUNDS	258,000	316,000	328,000	336,000	336,000	336,000
	KILOGRAMS	117,100	143,500	148,900	152,500	152,500	152,500
MAXIMUM LANDING WEIGHT	POUNDS	190,000	207,000	207,000	215,000	247,000	247,000
	KILOGRAMS	86,300	94,000	94,000	97,500	112,100	112,100
MAXIMUM TAKEOFF WEIGHT	POUNDS	257,340	312,000	327,000	333,600***	333,600***	333,600***
	KILOGRAMS	117,000	141,700	148,500	151,500	151,500	151,500
OPERATING EMPTY WEIGHT (TYP)	POUNDS	127,500 **	142,600 *	142,780 **	148,800 *	155,100 *	148,300 *
	KILOGRAMS	57,600	64,600	64,700	67,500	70,500	67,300
ZERO FUEL WEIGHT	POUNDS	170,000	190,000	190,000	195,000	230,000	230,000
	KILOGRAMS	77,200	86,300	86,300	88,500	104,400	104,400
MAXIMUM STRUCTURAL PAYLOAD	POUNDS	42,500	47,400	47,220	46,200	74,900	81,700
	KILOGRAMS	19,300	32,500	21,400	21,000	34,000	37,100
MAXIMUM SEATING CAPACITY See Pages 16 & 17.	ALL ECONOMY	174	189	189	189	194	—
MAXIMUM CARGO CAPACITY See Pages 20 & 21.	CUBIC FEET	1,668	1,773	1,770	1,770	1,700	9,115
	CUBIC METERS	47.39	50.24	50.16	50.16	48.36	258.0
USABLE FUEL CAPACITY	U.S. GALLONS	17,330	23,820	23,855	23,855	23,855	23,855
	LITERS	65,590	90,160	90,290	90,290	90,290	90,290

NOTE: OEW'S SHOWN ARE AN AVERAGE AIRLINE VALUE.
IF SPECIFIC FIGURES ARE REQUIRED, CONSULT USING AIRLINE.

* INTERNATIONAL CONFIGURATION

** DOMESTIC CONFIGURATION

*** MAXIMUM TAKEOFF WEIGHT OF 335,000 POUNDS
IS POSSIBLE WHEN USING WET THRUST.

GENERAL CHARACTERISTICS
MODEL 707

D6-58322

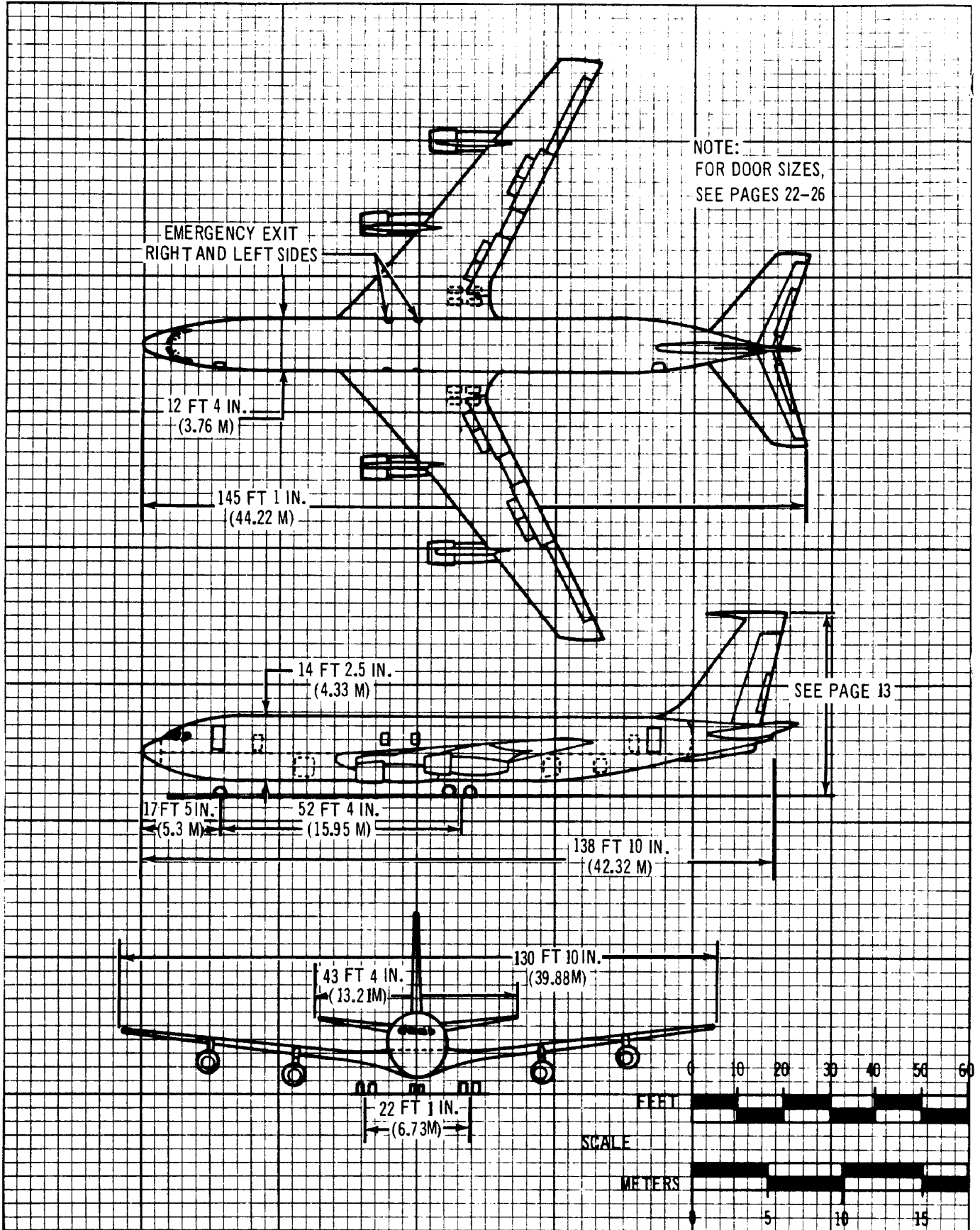

2.2 GENERAL DIMENSIONS
MODEL 707-120B

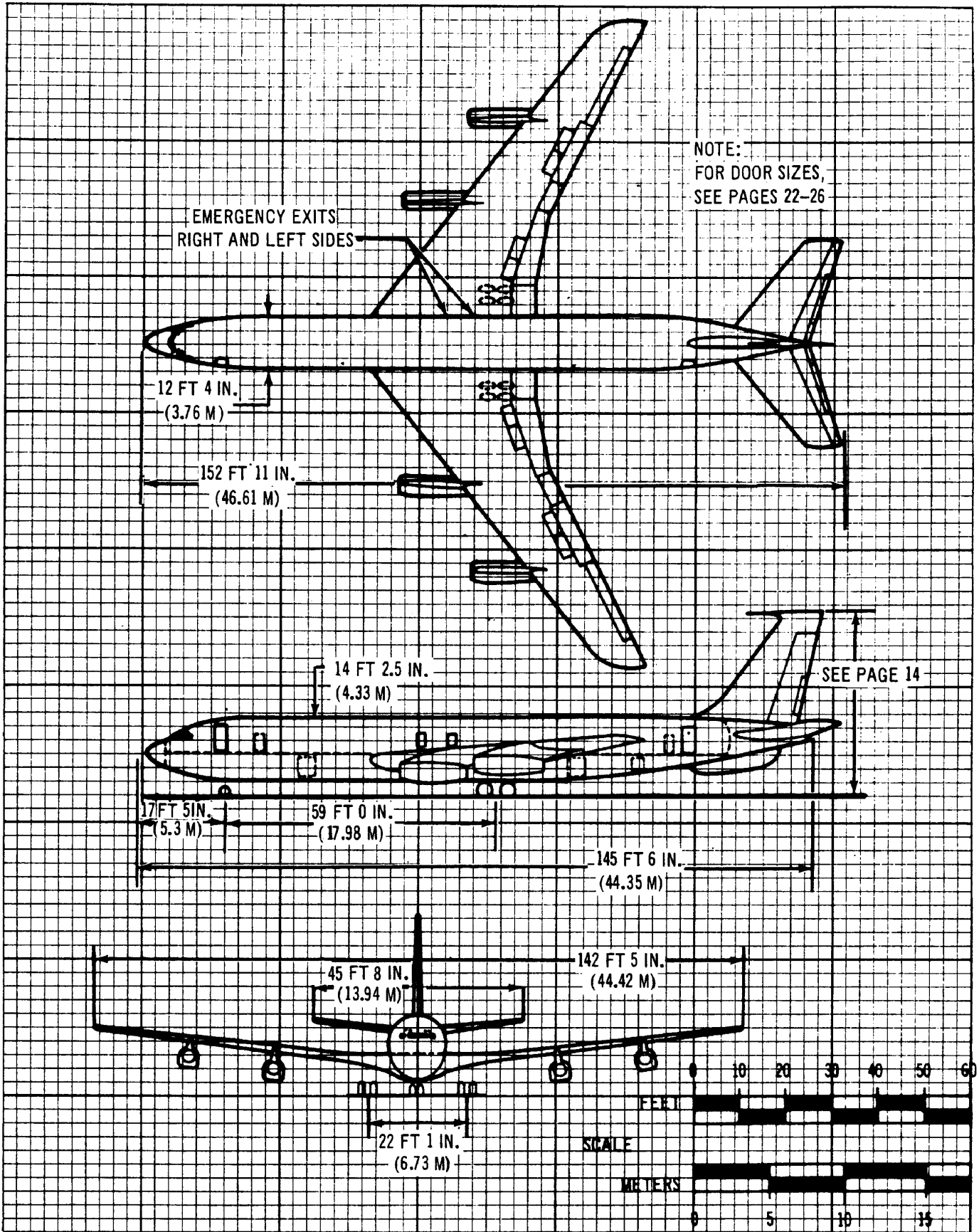

GENERAL DIMENSIONS
MODELS 707-320, -420

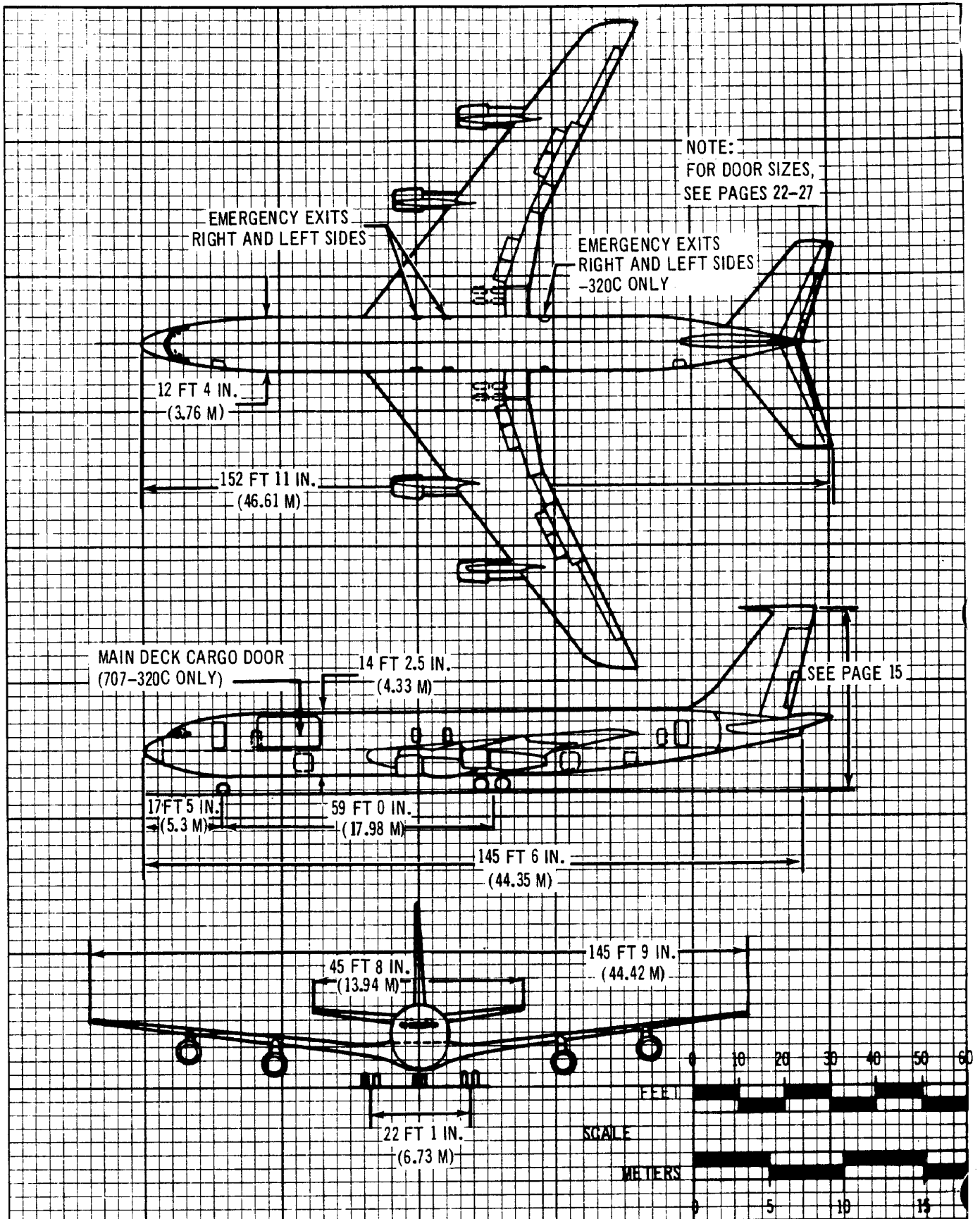

**GENERAL DIMENSIONS
MODELS 707-320B, -320C**

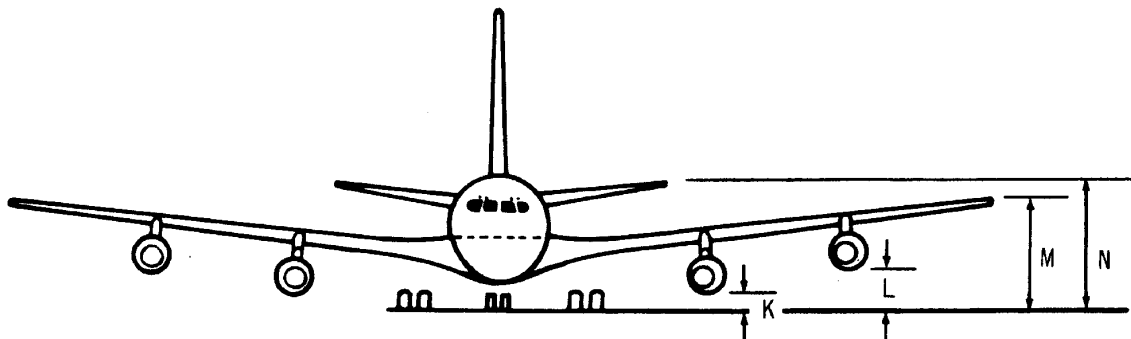
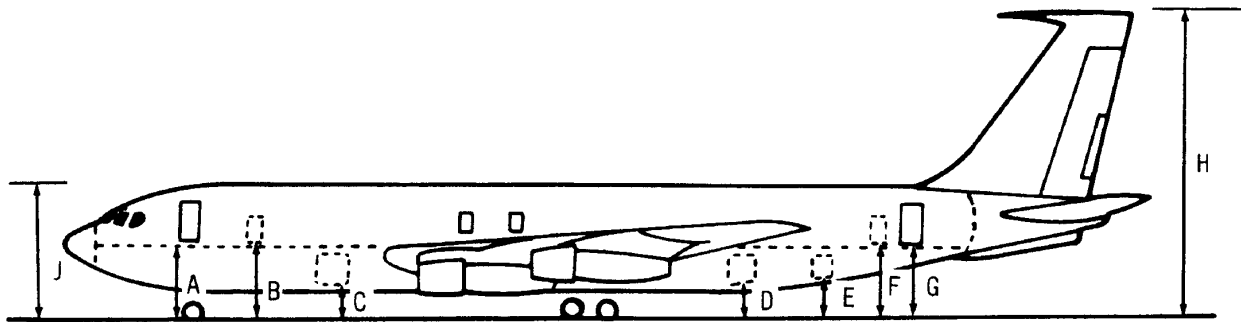

	VERTICAL CLEARANCES			
	OPERATING EMPTY WEIGHT		MAXIMUM RAMP WEIGHT	
	FT-IN.	M	FT-IN.	M
A	10 - 6	3.20	9 - 11	3.02
B	10 - 5	3.18	9 - 11	3.02
C	4 - 11	1.50	4 - 6	1.37
D	5 - 0	1.52	4 - 8	1.42
E	6 - 2	1.88	5 - 11	1.80
F	10 - 3	3.12	10 - 1	3.07
G	10 - 3	3.12	10 - 1	3.07
H	41 - 8	12.70	41 - 7	12.68
J	18 - 4	5.59	18 - 0	5.49
K	2 - 6	0.76	2 - 4	0.71
L	4 - 9	1.45	4 - 2	1.27
M	12 - 4	3.76	11 - 7	3.53
N	16 - 10	5.13	16 - 9	5.11

**2.3 GROUND CLEARANCES
MODEL 707-120B**

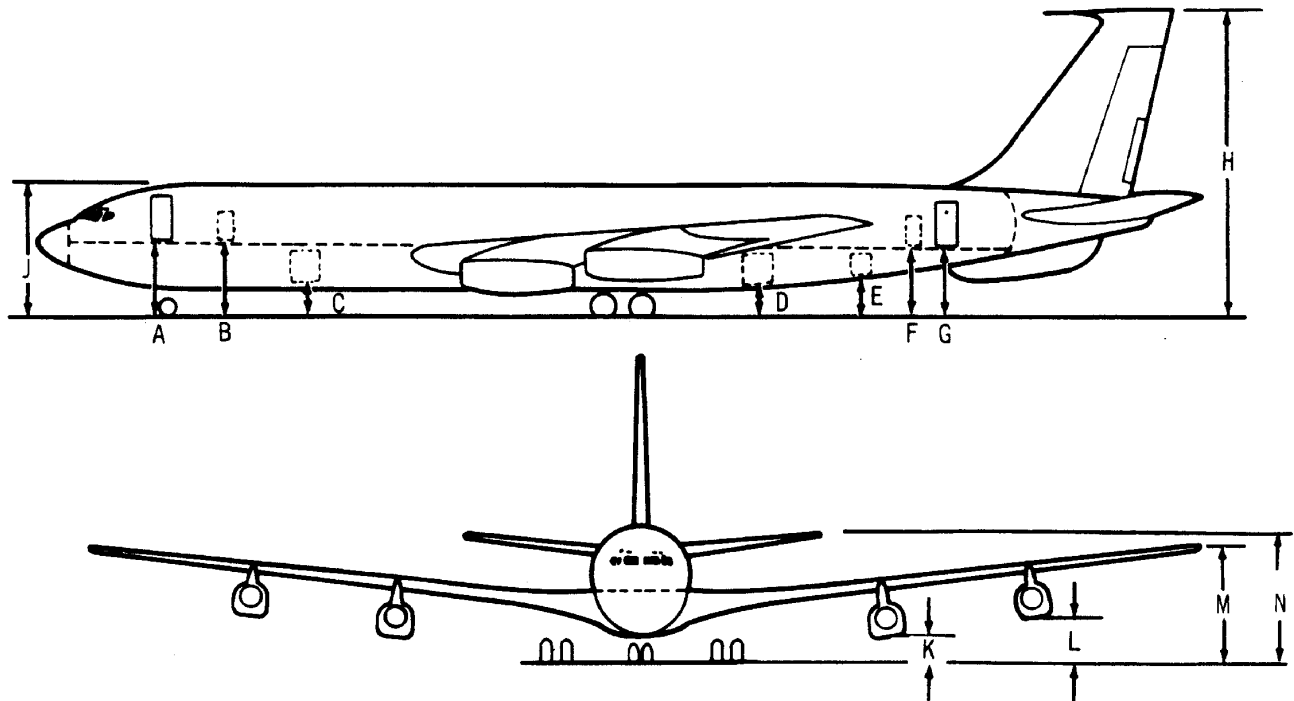

	VERTICAL CLEARANCES			
	OPERATING EMPTY WEIGHT		MAXIMUM RAMP WEIGHT	
	FT-IN.	M	FT-IN.	M
A	10 - 6	3.20	9 - 11	3.02
B	10 - 6	3.20	10 - 0	3.05
C	5 - 1	1.55	4 - 6	1.37
D	5 - 3	1.60	4 - 11	1.50
E	6 - 5	1.96	6 - 2	1.88
F	10 - 8	3.25	10 - 4	3.15
G	10 - 8	3.25	10 - 4	3.15
H	42 - 2	12.85	41 - 11	12.78
J	18 - 7	5.66	18 - 0	5.49
K	3 - 3	0.99	2 - 9	0.84
L	5 - 3	1.60	4 - 7	1.40
M	13 - 0	3.96	12 - 1	3.68
N	17 - 6	5.33	17 - 3	5.26

**GROUND CLEARANCES
MODELS 707-320, -420**

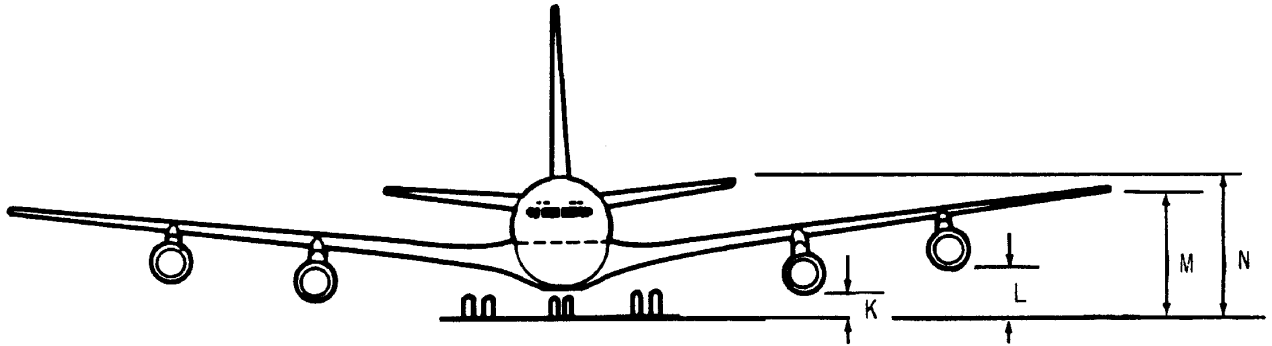
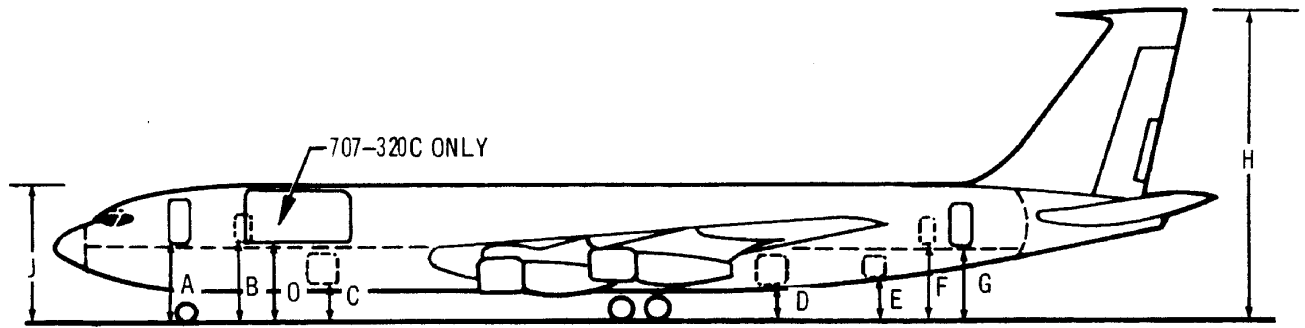

	VERTICAL CLEARANCES							
	OPERATING EMPTY WEIGHT				MAXIMUM RAMP WEIGHT			
	320B		320C		320B		320C	
	FT - IN.	M	FT - IN.	M	FT - IN.	M	FT - IN.	M
A	10 - 6	3.20	10 - 8	3.25	9 - 11	3.02	10 - 0	3.05
B	10 - 6	3.20	10 - 7	3.23	10 - 0	3.05	10 - 0	3.05
C	5 - 1	1.55	5 - 1	1.55	4 - 6	1.37	4 - 6	1.37
D	5 - 3	1.60	4 - 10	1.47	5 - 2	1.58	4 - 10	1.47
E	6 - 5	1.96	6 - 4	1.93	6 - 1	1.85	6 - 0	1.83
F	10 - 7	3.23	10 - 6	3.20	10 - 3	3.12	10 - 3	3.12
G	10 - 7	3.23	10 - 6	3.12	10 - 3	3.20	10 - 3	3.12
H	42 - 1	12.83	42 - 0	12.80	41 - 10	12.75	41 - 10	12.75
J	18 - 7	5.66	18 - 6	5.64	18 - 0	5.49	18 - 1	5.51
K	3 - 4	1.02	3 - 4	1.02	2 - 9	0.84	2 - 9	0.84
L	5 - 4	1.63	5 - 4	1.63	4 - 7	1.40	4 - 7	1.40
M	13 - 1	3.99	13 - 0	3.96	12 - 2	3.71	12 - 1	3.68
N	17 - 4	5.28	17 - 3	5.26	17 - 2	5.23	17 - 1	5.21
O			10 - 6	3.20			9 - 11	3.02

GROUND CLEARANCES
MODELS 707-320B, -320C

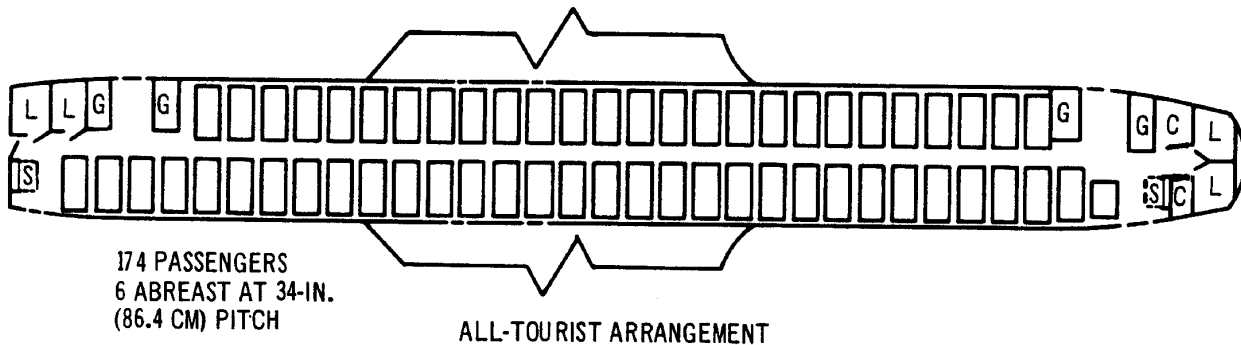
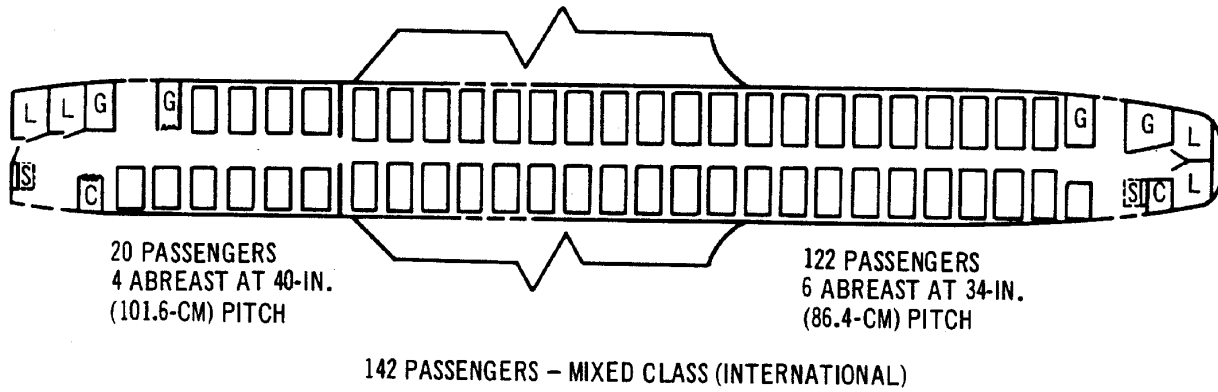
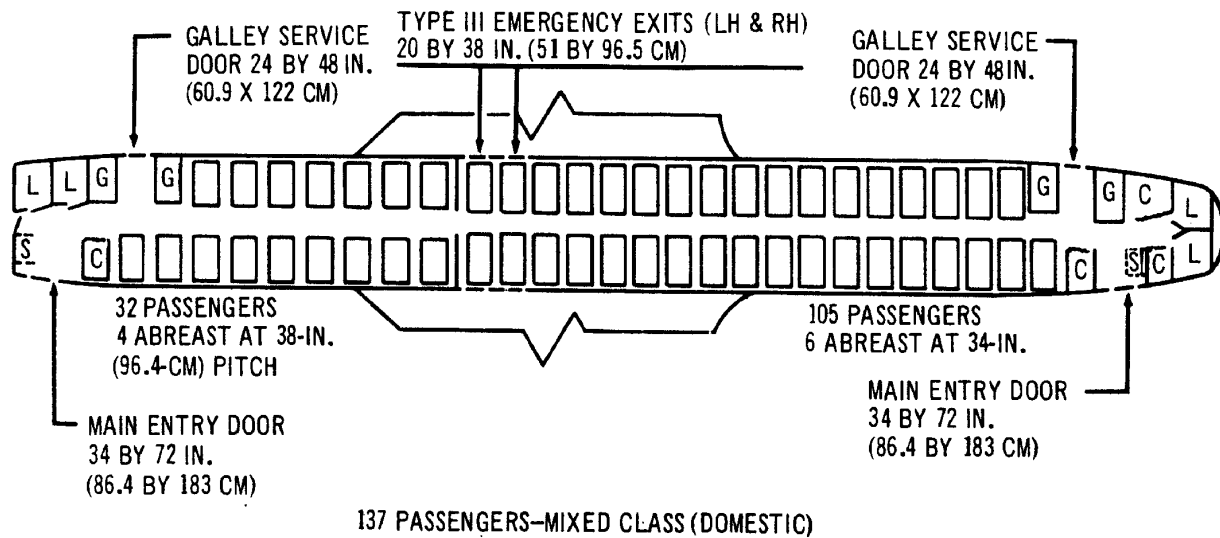

- C CLOSET
- G GALLEY
- L LAVATORY
- S DOUBLE ATTENDANTS SEAT

2.4 INTERIOR ARRANGEMENT - PASSENGER
MODEL 707-120B

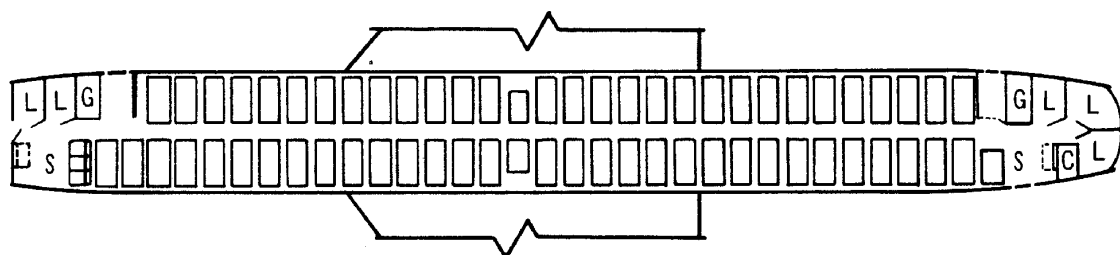
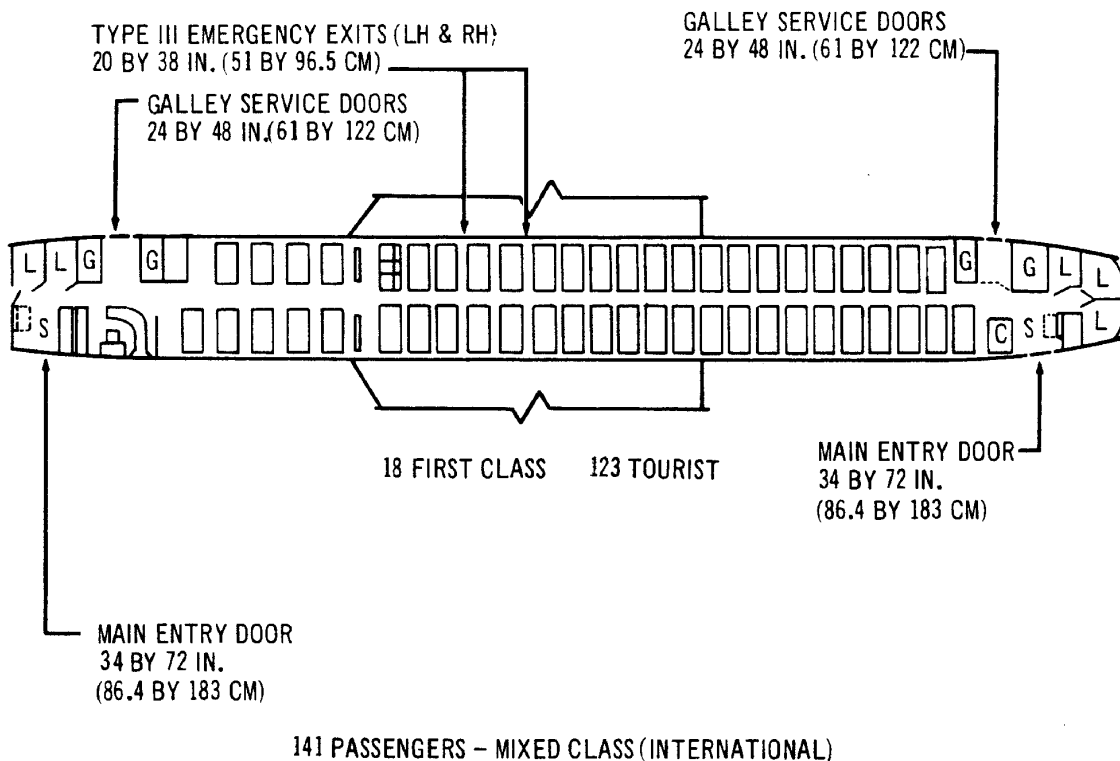

- C** CLOSET
- G** GALLEY
- L** LAVATORY
- S** DOUBLE ATTENDANTS SEAT

**INTERIOR ARRANGEMENT - PASSENGER
MODEL 707-320, -320B, -420**

THREE TO 10 PALLETS CAN BE ACCOMMODATED IN MIXED CARGO/PASSENGER CONFIGURATIONS. VARIOUS COMBINATIONS ARE SHOWN BELOW.

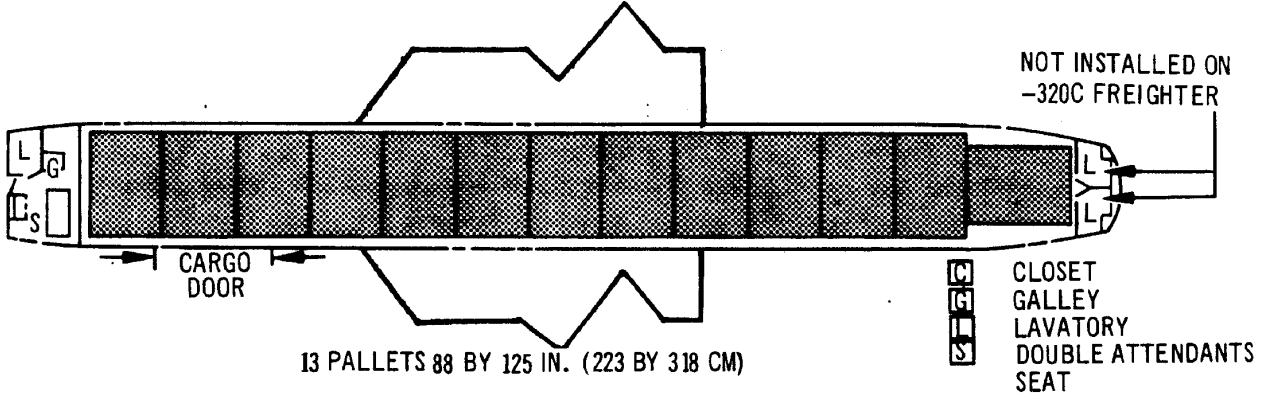
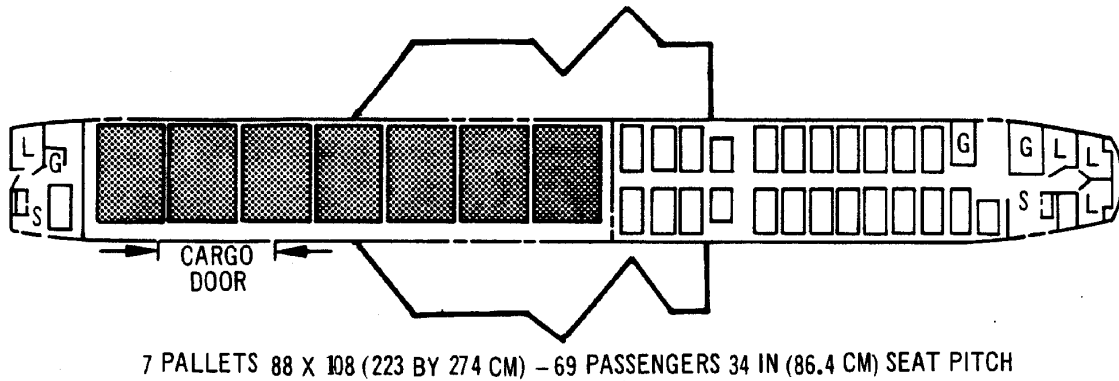
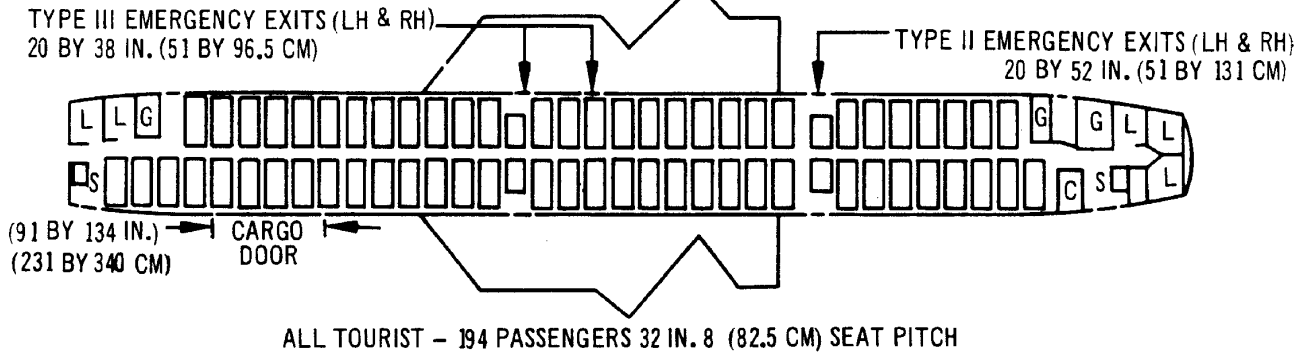

PASSENGERS
(34-IN. PITCH)
(86.4-CM PITCH)

NO.	PALLETS	
	SIZE	
	IN.	(CM)
0	88 BY 108	(223 BY 274)
3	88 BY 108	(223 BY 274)
4	88 BY 108	(223 BY 274)
5	88 BY 108	(223 BY 274)
6	88 BY 108	(223 BY 274)
7	88 BT 108	(223 BY 274)
8	88 BT 108	(223 BY 274)
9	88 BT 108	(223 BY 274)
10	88 BY 108	(223 BY 274)
13	88 BY 108 (BASIC)	(223 BY 274)
13	88 BY 125 (OPTIONAL)	223 BY 318

TOTAL CARGO VOLUMES
(INCLUDING LOWER CARGO
COMPARTMENTS)

CU FT	(CU M)
1,700	(48.14)
2,906	(82.30)
3,317	(93.94)
3,728	(105.58)
4,139	(117.22)
4,550	(128.86)
4,961	(140.50)
5,372	(152.14)
5,783	(163.77)
7,022	(198.86)
7,630	(216.08)

**INTERIOR ARRANGEMENT - CARGO/PASSENGER
MODEL 707-320C**

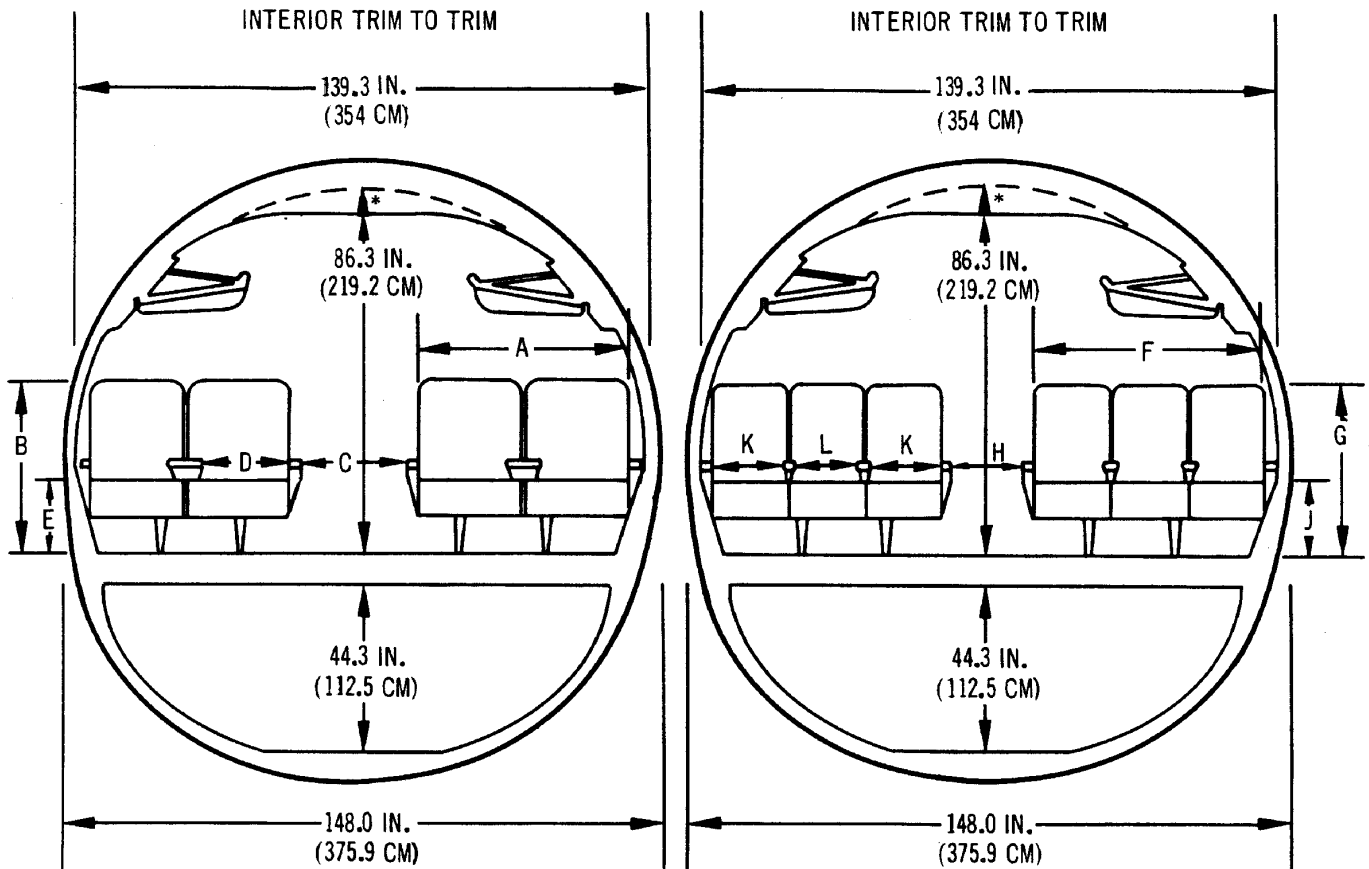

* 91.3 IN. (232 CM) -320C ONLY

	IN.	CM
A	47.4	120.4
B	42.6	107.9
C	28.0	71.2
D	20.0	50.8
E	17.9	45.5

FIRST CLASS

	IN.	CM
F	54.4	138.2
G	42.6	107.9
H	18.0	45.7
J	17.9	45.5
K	16.5	41.9
L	17.6	44.7

TOURIST

2.5 CABIN CROSS SECTIONS - PASSENGER
 MODELS 707-120B, -320, -320B, -320C, -420

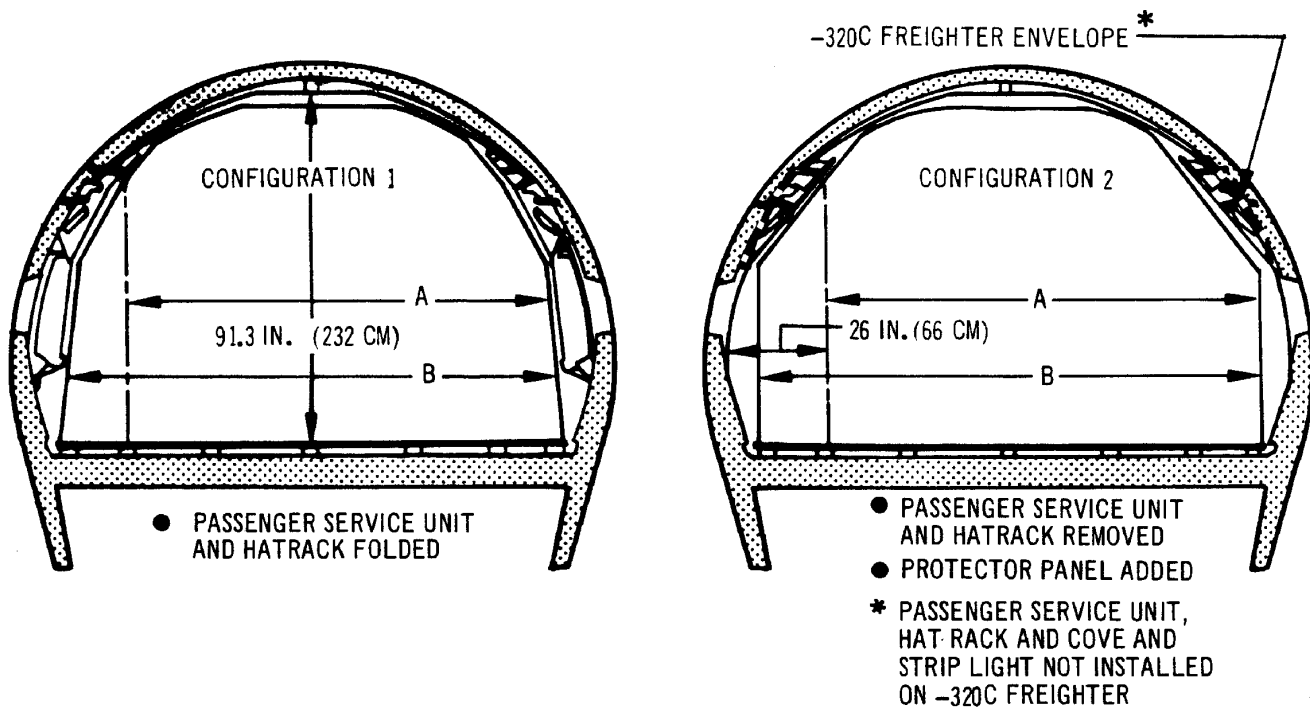

PALLET ENVELOPES BASED ON 1-INCH MINIMUM CLEARANCE (PALLETS 2 THRU 12)

-320C CONVERTIBLE PALLETIZED CARGO VOLUMES				
CONFIGURATION 1			CONFIGURATION 2	
PALLET A	PALLET B		PALLET A	PALLET B
88 BY 108 IN. (2.23 BY 2.74 M)	88 BY 125 IN. (2.23 BY 3.18 M)		88 BY 108 IN. (2.23 BY 2.74 M)	88 BY 108 IN. (2.23 BY 3.18 M)
403 CU FT (11.4 CU M)	441 CU FT (12.49 CU M)	ONE PALLET	411 CU FT (12.91 CU M)	456 CU FT (11.64 CU M)
5,227 CU FT (148.03 CU M)	5,758 CU FT (163.07 CU M)	TOTAL ENVELOPE (13 PALLETS)	5,322 CU FT (150.72 CU M)	5,930 CU FT (167.94 CU M)

GROSS CARGO COMPARTMENT VOLUMES		
	-320C CONVERTIBLE	-320C FREIGHTER
UPPER COMPARTMENT (WETTED VOL)	7,415 CU FT (209.64 CU M)	8,000 CU FT (226.5 CU M)
LOWER COMPARTMENT	1,700 CU FT (48.36 CU M)	1,785 CU FT (50.5 CU M)
TOTAL	9,115 CU FT (257 CU M)	9,785 CU FT (277 CU M)

NOTE:

WHEN 108-INCH (2.74-METER) PALLETS(A) ARE USED IN CARGO-PASSENGER CONFIGURATIONS, THERE IS A CREW ACCESS AISLE TO THE PASSENGER COMPARTMENT. THE 125-INCH (3.18-METER) PALLETS (B) UTILIZE THE FULL CABIN WIDTH. SEE PAGE 19.

**UPPER CARGO COMPARTMENT CROSS SECTIONS -
CONVERTIBLE AND FREIGHTER
MODEL 707-320C**

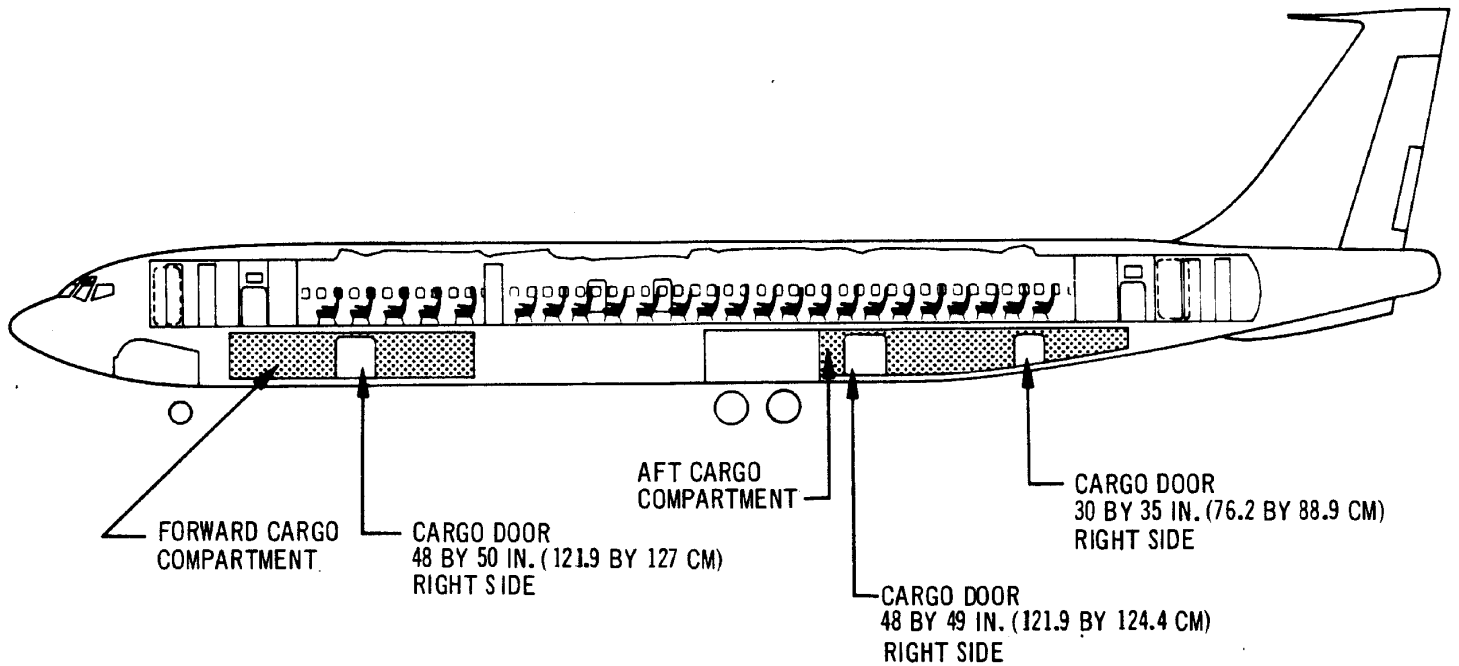

LOWER CARGO COMPARTMENT CAPACITIES

MODEL	FORWARD		AFT		TOTAL	
	CU FT	CU M	CU FT	CU M	CU FT	CU M
707-120B	758	21.46	910	25.76	1,668	47.22
707-320/-420	868	24.58	905	25.63	1,773	50.21
707-320B	865	24.49	905	25.63	1,770	50.12
707-320C (CONV)	835	23.60	865	24.49	1,700	48.09
707-320C (F)	875	24.80	910	25.76	1,785	50.56

NOTE: CARGO IN LOWER COMPARTMENTS NOT USUALLY CONTAINERIZED; HOWEVER, INDIVIDUAL AIRLINES HAVE OPTION OF USING CONTAINERS.

2.6 LOWER CARGO COMPARTMENT CAPACITIES
 MODELS 707-120B, -320, -320B, -320C, -420

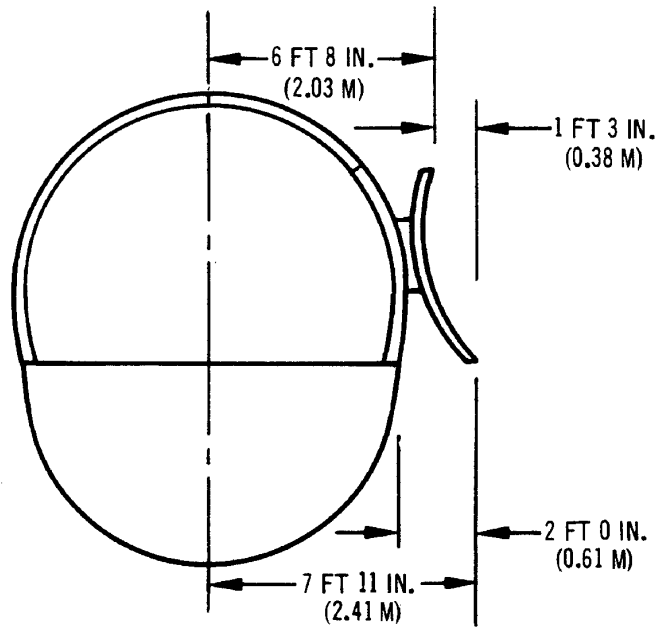
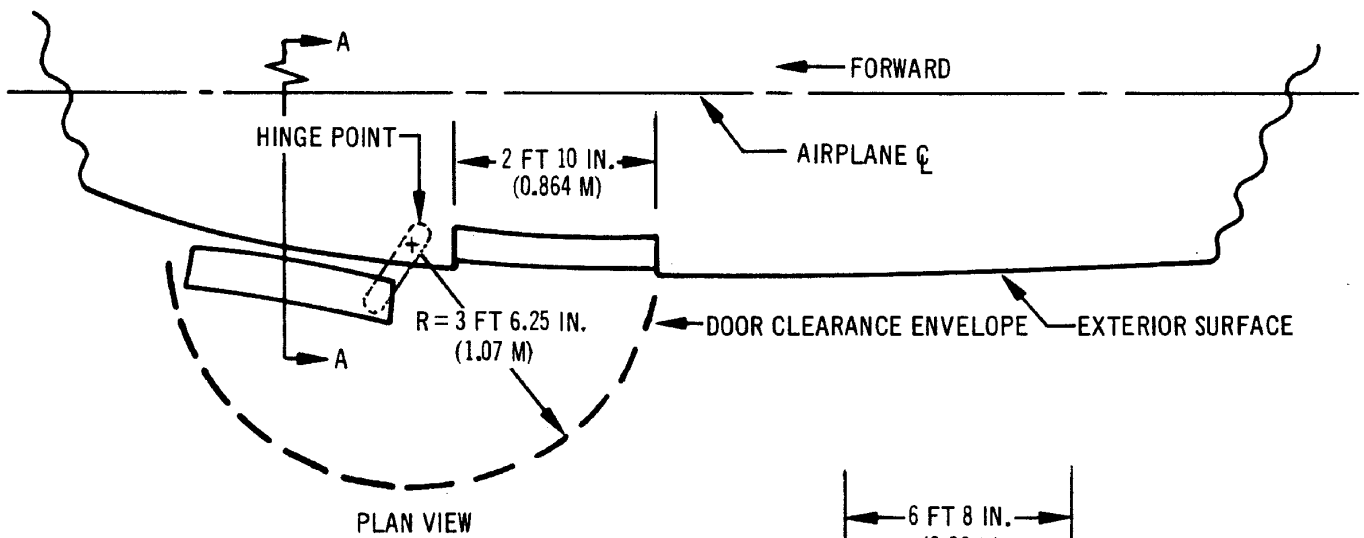
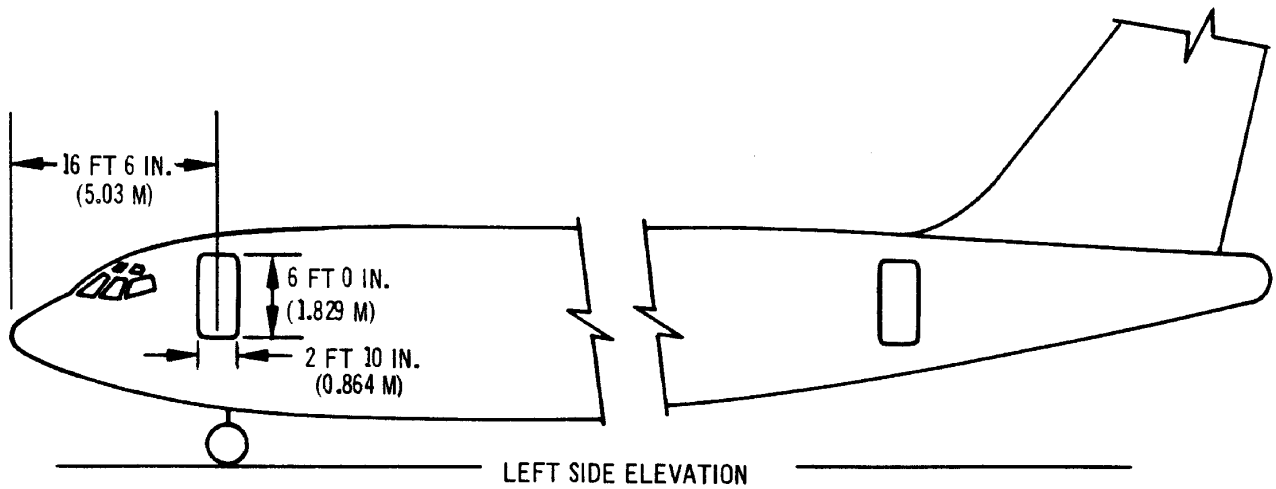

NOTE: FOR DOOR SILL HEIGHTS ABOVE GROUND, SEE PAGES 13, 14, 15.

**2.7 DOOR CLEARANCES - FORWARD PASSENGER ENTRY
MODELS 707-120B, -320, -320B, -320C, -420**

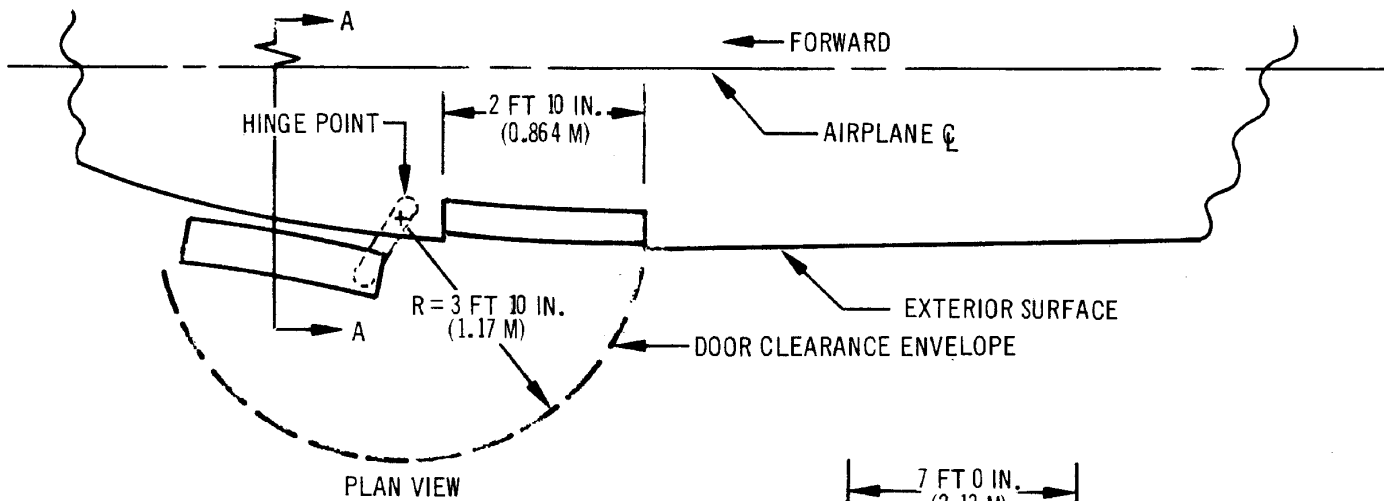
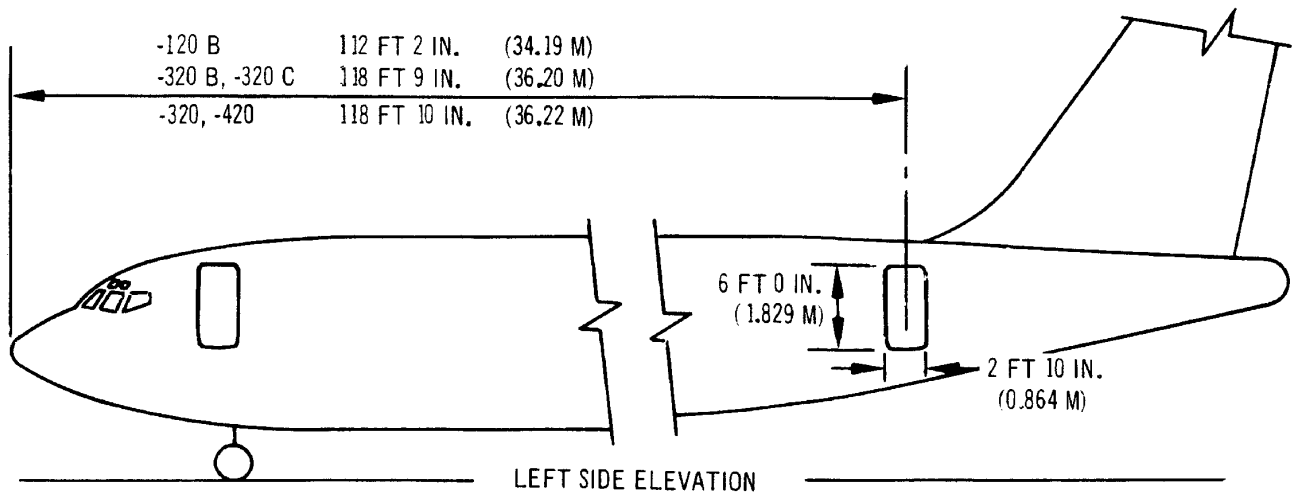

NOTE: FOR DOOR SILL HEIGHTS ABOVE GROUND, SEE PAGES 13, 14, 15.

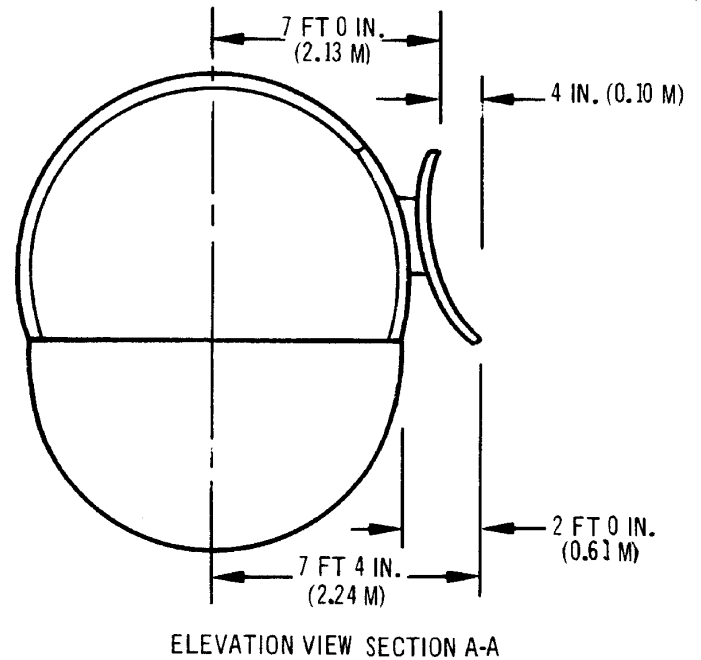

**DOOR CLEARANCES - AFT PASSENGER ENTRY
MODELS 707-120B, -320, -320B, -320C, -420**

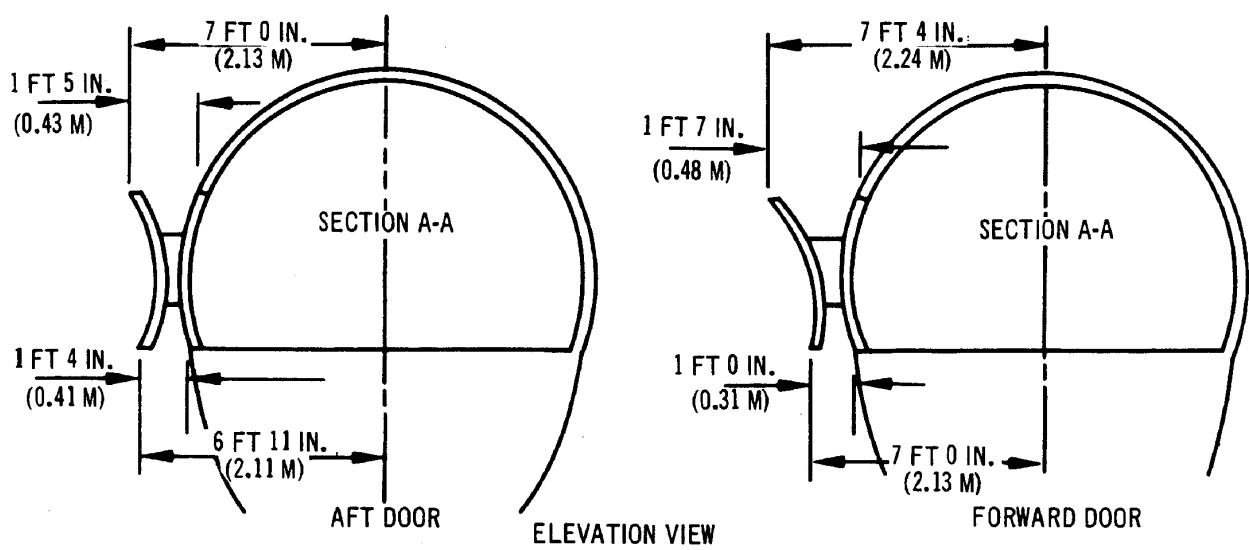
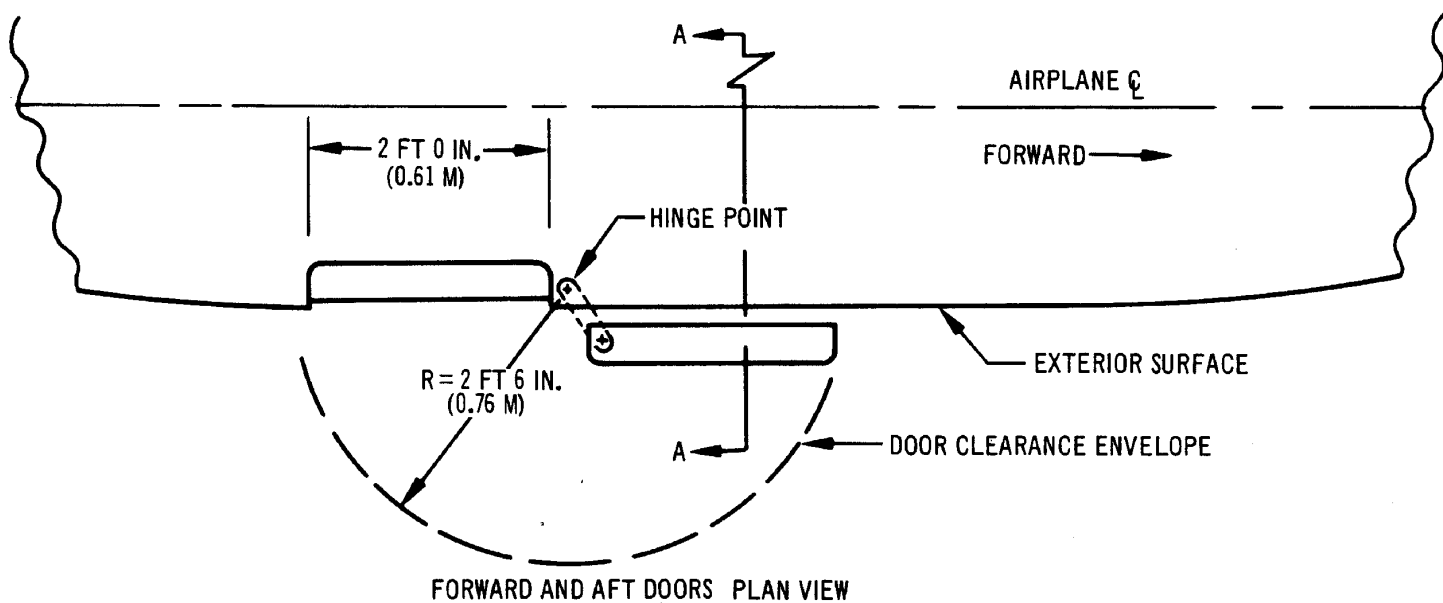
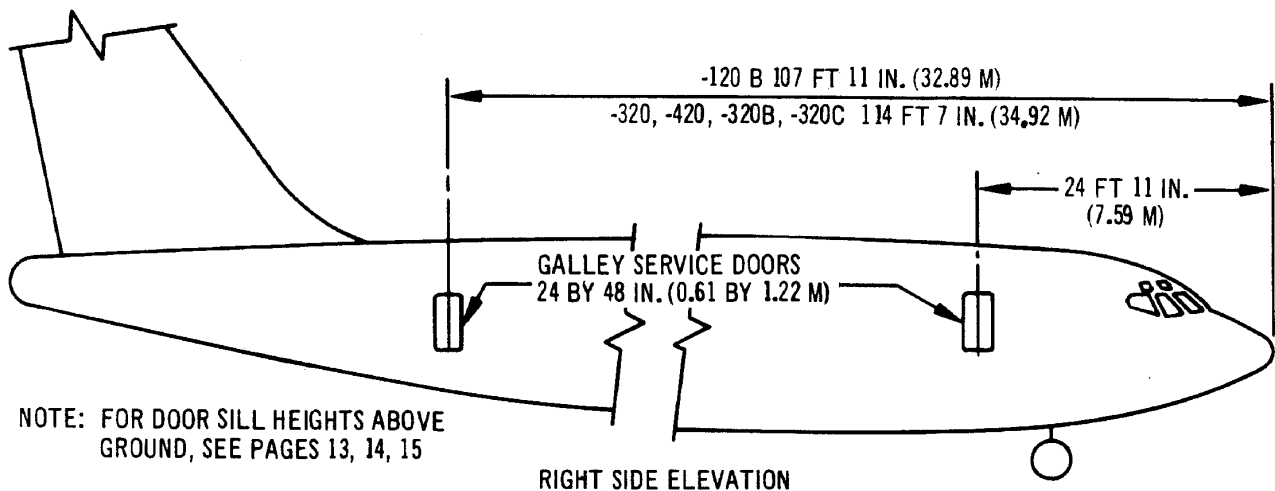

**DOOR CLEARANCES - FORWARD AND AFT GALLEY SERVICE
MODELS 707-120B, -320, -320B, -320C, -420**

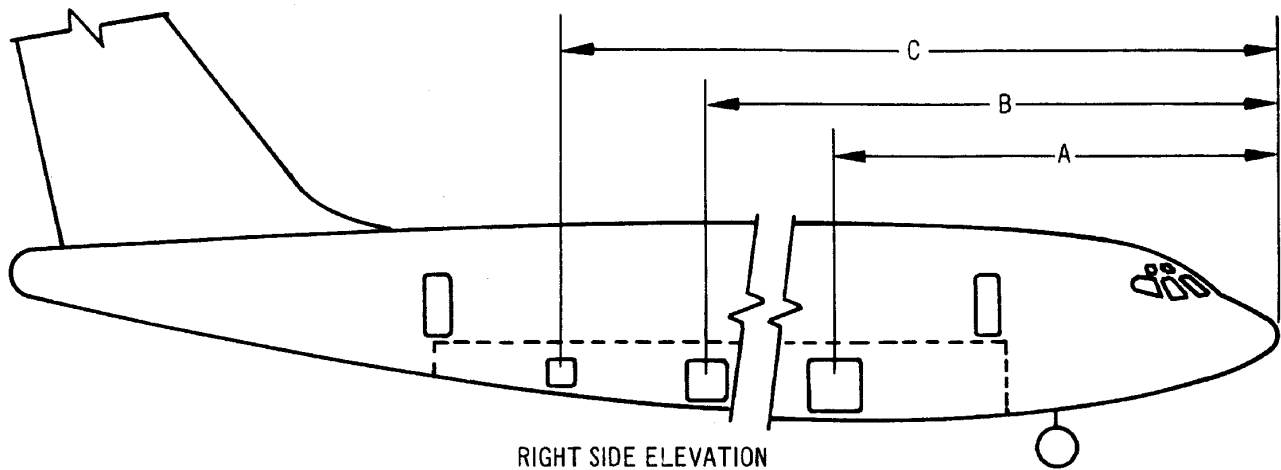

RIGHT SIDE ELEVATION

NOTE: FOR DOOR SILL HEIGHTS ABOVE GROUND, SEE PAGES 13, 14 AND 15

DOOR	MODEL					
	-120B		-320 / -420		-320B / -320C	
	FT	M	FT	M	FT	M
FORWARD CARGO COMPARTMENT (DOOR A) 48 IN. WIDE BY 50 IN. HIGH (1.22 BY 1.27 M)	35 FT 4.2 IN.	10.77	35 FT 4.2 IN.	10.77	35 FT 4.2 IN.	10.77
AFT CARGO COMPARTMENT (FORWARD DOOR B) 48 IN. WIDE BY 49 IN. HIGH (1.22 BY 1.24 M)	86 FT 3.5 IN.	26.30	94 FT 7.5 IN.	28.84	94 FT 7.5 IN.	28.84
(AFT DOOR C) 30 IN. WIDE BY 35 IN. HIGH (0.76 BY 0.89 M)	98 FT 10.5 IN.	30.14	107 FT 2.5 IN.	32.68	107 FT 2.5 IN.	32.68

NOTE: LOWER CARGO COMPARTMENT DOORS DO NOT SWING OUT. TRACKS LOCATED ON INTERIOR SIDEWALL PERMIT DOOR TO SLIDE BACK FROM DOOR OPENING.

DOOR CLEARANCES - LOWER CARGO MODELS 707-120B, -320, -320B, -320C, -420

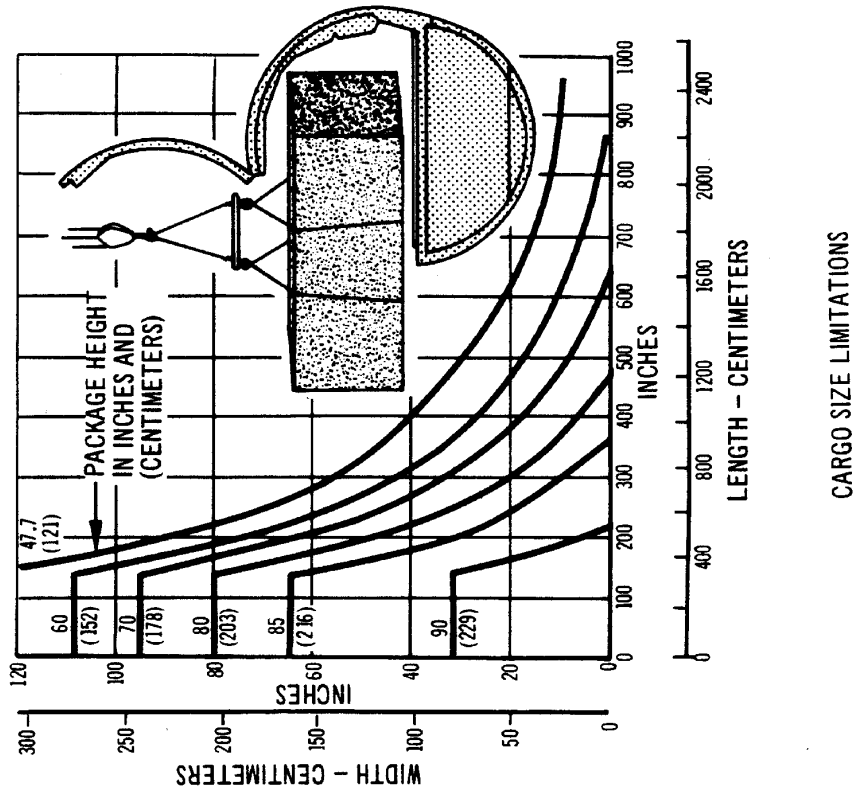
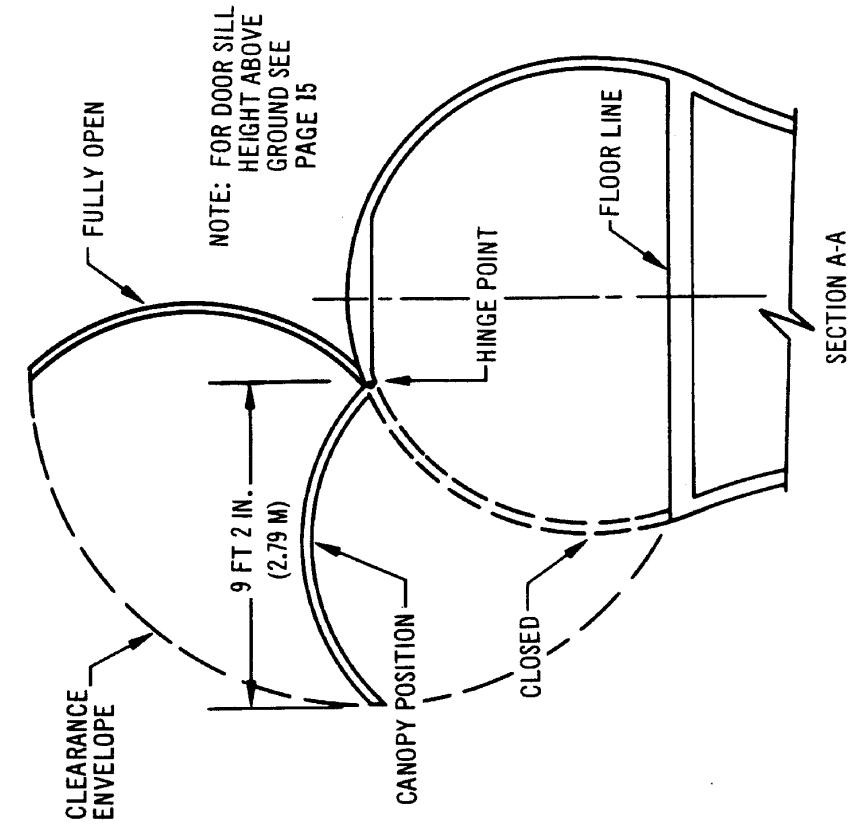
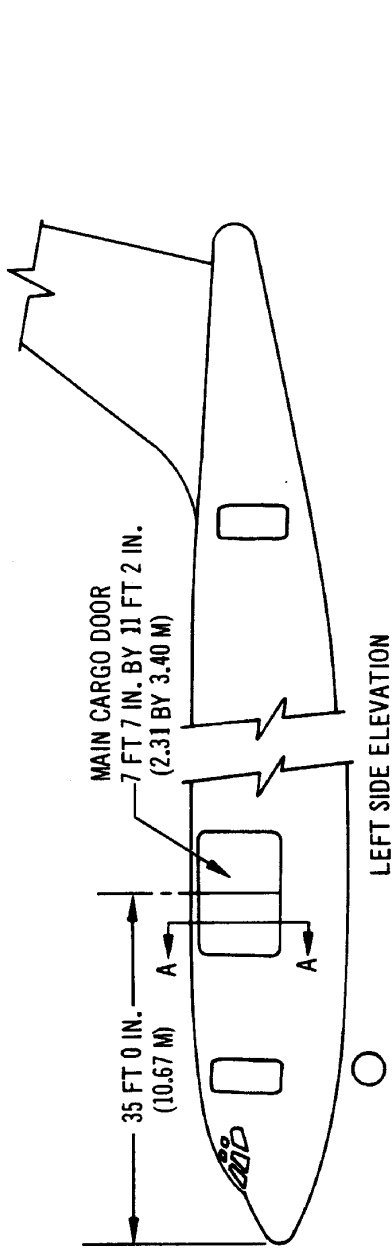

DOOR CLEARANCES - MAIN CARGO MODEL 707-320C

WING HIGH POINT		DISTANCE FROM AIRPLANE CENTERLINE	DISTANCE FROM NOSE	DISTANCE FROM FORWARD ENTRY DOOR CENTERLINE	DISTANCE FROM AFT ENTRY DOOR CENTERLINE	DISTANCE ABOVE TOP OF DOOR SILL PLANE	
						IN.	CM
A	FT-IN.	8-4	49-6	33-0	62-8	IN.	3.76
	M	2.54	15.1	10.05	19.1	CM	9.55
B	FT-IN.	12-6	53-2	36-8	59-0	IN.	3.41
	M	3.81	16.2	11.2	18.0	CM	8.66
C	FT-IN.	16-8	56-11	40-5	55-3	IN.	3.69
	M	5.08	17.3	12.3	16.8	CM	9.38
D	FT-IN.	20-10	60-8	44-2	51-6	IN.	4.73
	M	6.35	18.5	13.5	15.7	CM	12.0
E	FT-IN.	25-0	64-2	51-10	48-0	IN.	8.14
	M	7.62	20.8	15.8	14.6	CM	20.7
F	FT-IN.	29-2	70-3	53-9	41-11	IN.	12.20
	M	8.89	21.4	16.4	12.8	CM	31.0
G	FT-IN.	33-4	72-1	55-7	40-1	IN.	14.42
	M	10.16	22.0	16.9	12.3	CM	36.6
H	FT-IN.	37-6	74-10	58-4	37-4	IN.	18.52
	M	11.43	22.8	17.8	11.3	CM	47.0

NOTE: ● WING CLEARANCES ARE MEASURED RELATIVE TO TOP OF DOOR SILL PLANE.
 ● SEE PAGE 13 FOR DOOR SILL HEIGHT ABOVE GROUND.
 ● AIRPLANE IS IN LEVEL ATTITUDE WITH NO WING DEFLECTION.

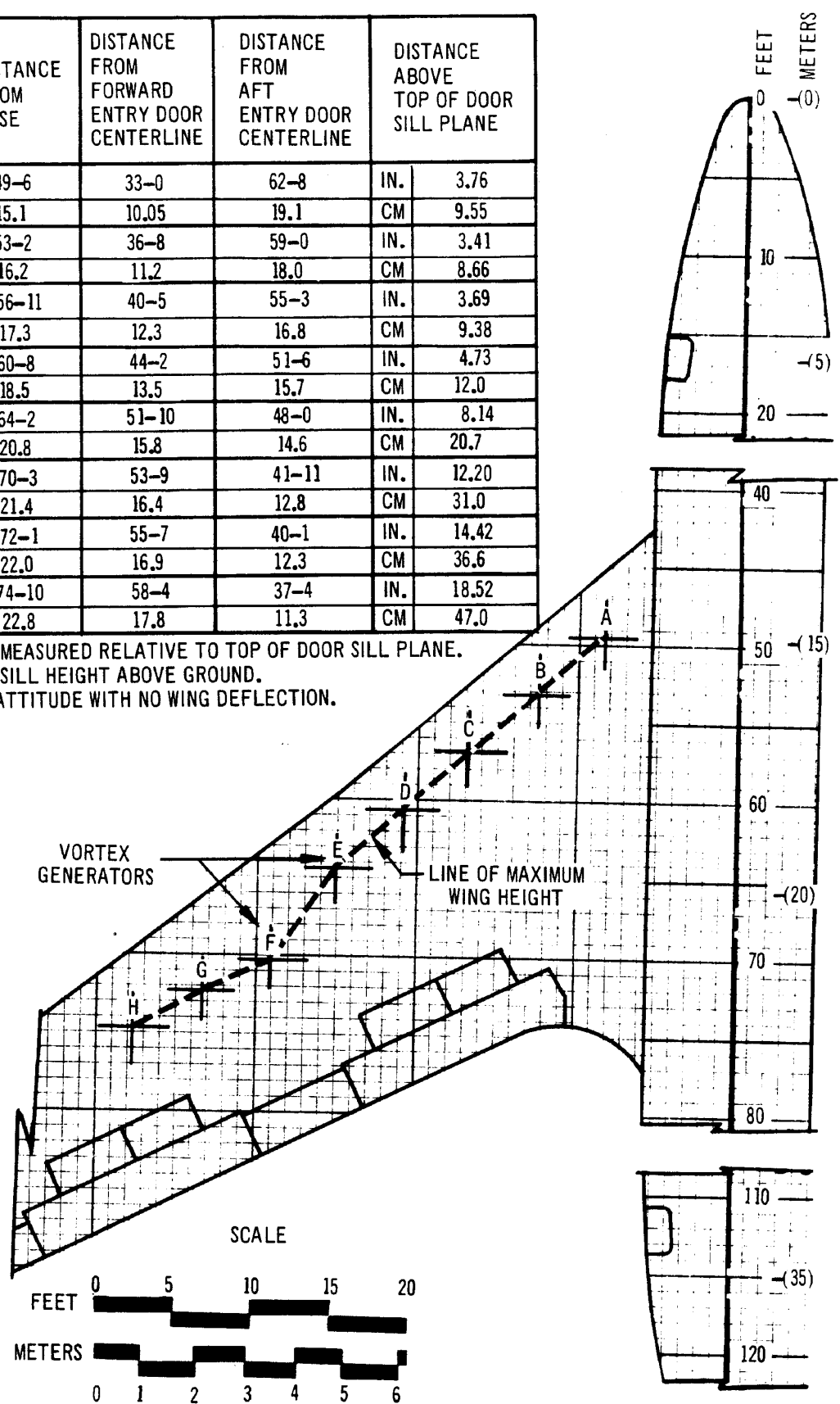

**DOOR SILL/WING CLEARANCE — CRITICAL INTERFERENCE PATH
 MODEL 707-120B**

D6-58322

WING HIGH POINT	DISTANCE FROM AIRPLANE CENTERLINE		DISTANCE FROM NOSE		DISTANCE FROM FORWARD ENTRY DOOR CENTERLINE		DISTANCE FROM AFT ENTRY DOOR CENTERLINE		DISTANCE ABOVE (+) OR BELOW (-) TOP OF DOOR SILL PLANE	
	FT-IN.	M	FT-IN.	M	FT-IN.	M	FT-IN.	M	IN.	CM
A	FT-IN.	8-4	57-11	41-7	60-11	IN.	-3.69			
	M	2.54	17.77	12.6	18.6	CM	-9.39			
B	FT-IN.	12-6	61-10	45-4	57-0	IN.	-2.08			
	M	3.81	18.89	13.8	17.3	CM	-5.28			
C	FT-IN.	16-8	65-5	49-1	53-5	IN.	+0.18			
	M	5.08	19.90	14.8	16.3	CM	+0.46			
D	FT-IN.	20-10	68-0	51-6	50-10	IN.	+3.57			
	M	6.35	20.80	15.7	15.5	CM	+9.07			
E	FT-IN.	25-0	70-8	54-2	48-2	IN.	+7.28			
	M	7.62	21.5	16.5	14.7	CM	+18.50			
F	FT-IN.	29-2	75-7	59-1	43-3	IN.	+12.33			
	M	8.89	23.0	18.0	13.2	CM	+31.35			
G	FT-IN.	33-4	77-8	61-2	41-2	IN.	+16.46			
	M	10.16	23.7	18.6	12.6	CM	+41.80			
H	FT-IN.	37-6	79-9	63-3	39-1	IN.	+20.65			
	M	11.43	24.4	19.3	11.9	CM	+52.60			

NOTE: ● WING CLEARANCES ARE MEASURED RELATIVE TO TOP OF DOOR SILL PLANE.
 ● SEE PAGES 14 & 15 FOR DOOR SILL HEIGHT ABOVE GROUND.
 ● AIRPLANE IS IN LEVEL ATTITUDE WITH NO WING DEFLECTION.

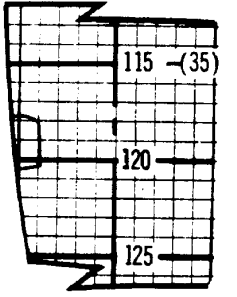
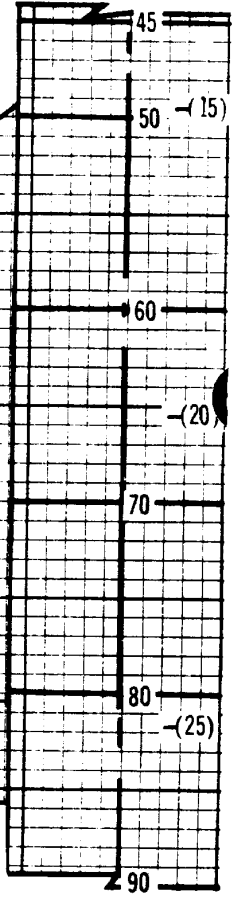
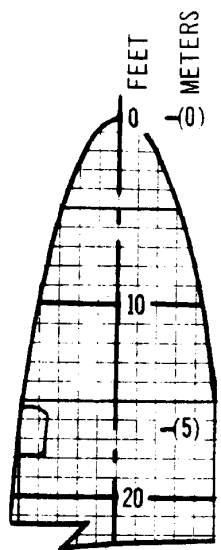
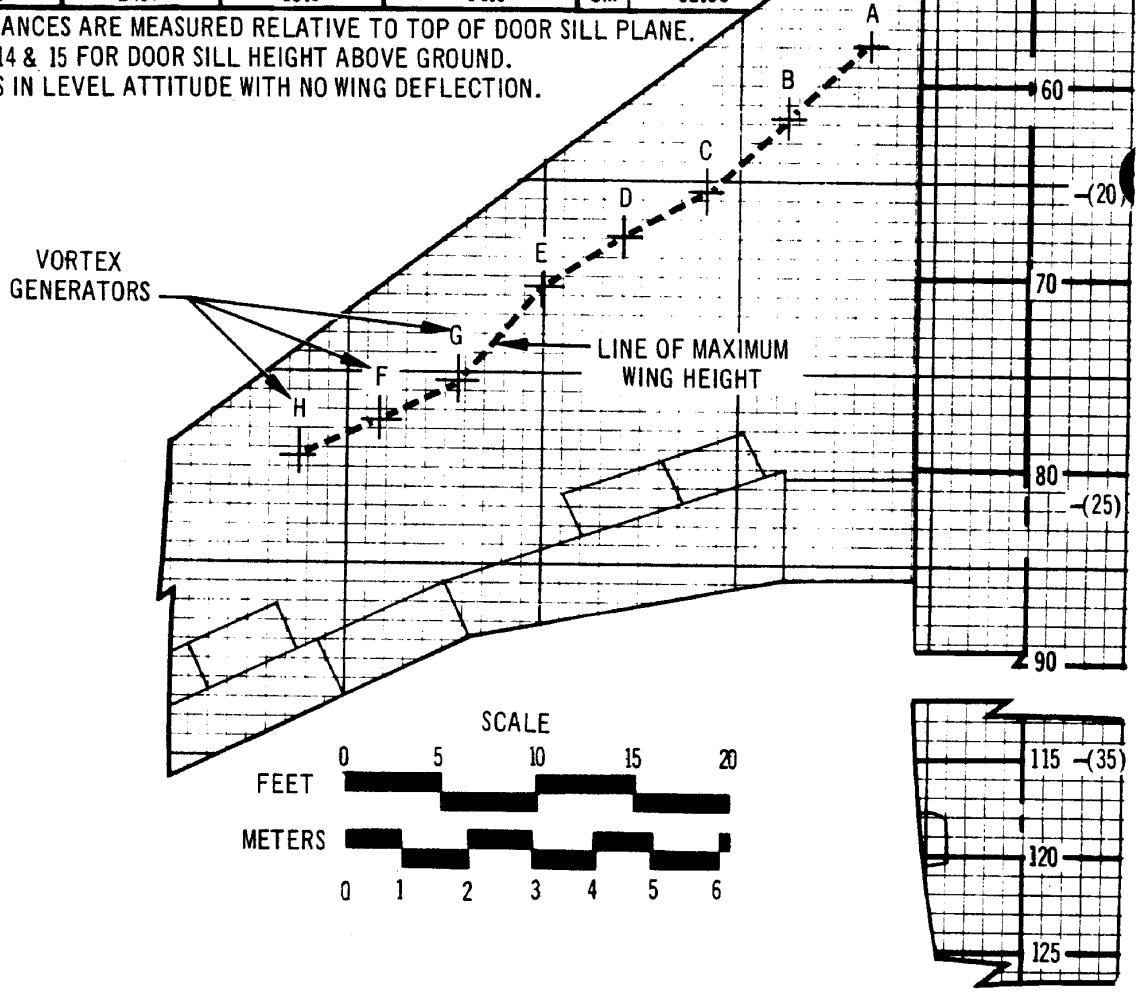

**DOOR SILL/WING CLEARANCE — CRITICAL INTERFERENCE PATH
 MODEL 707-320, -320B, -320C, -420**

3.0 AIRPLANE PERFORMANCE

3.1 Payload/Range for Long Range Cruise

3.2 C.A.R. Takeoff Runway Length Requirements

3.3 C.A.R. Landing Runway Length Requirements

NOTES: ● OEW = 127,500 LB (57,600 KG), AN AVERAGE AIRLINE VALUE;
IF SPECIFIC FIGURES ARE REQUIRED, CONSULT USING AIRLINE.

● JT3D-3 ENGINES

● STANDARD DAY—ZERO WIND

● ATA DOMESTIC FUEL RESERVES—200 NAUTICAL MILE ALTERNATE

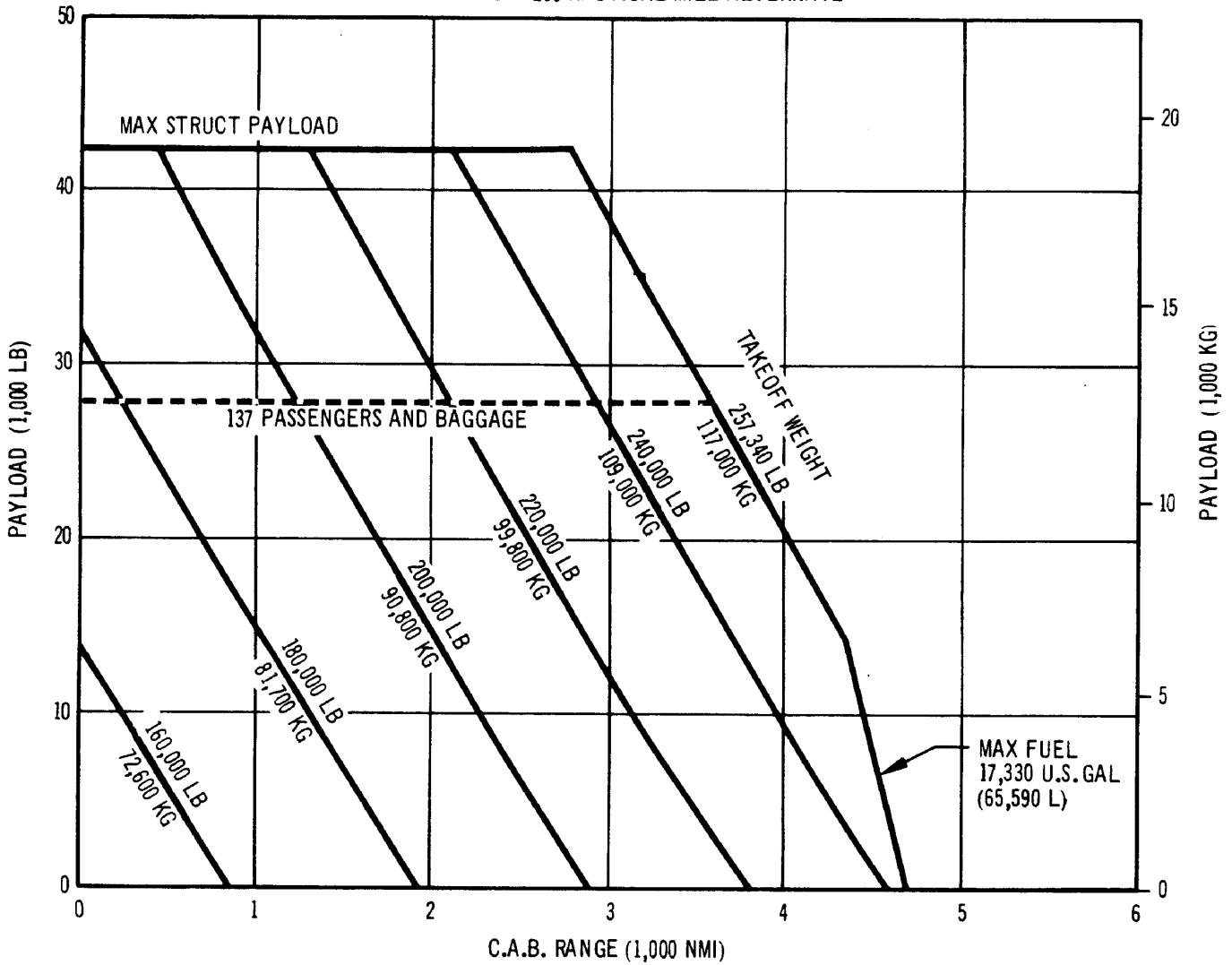

**3.1 PAYLOAD/RANGE FOR LONG RANGE STEP CLIMB CRUISE
MODEL 707-120B PASSENGER - DOMESTIC**

NOTES: ● OEW = 142,600 LB (64,600 KG), AN AVERAGE AIRLINE VALUE;
IF SPECIFIC FIGURES ARE REQUIRED, CONSULT USING AIRLINE.

- JT4A-11 ENGINES
- STANDARD DAY—ZERO WIND
- ATA INTERNATIONAL FUEL RESERVES – 200 NAUTICAL MILE ALTERNATE

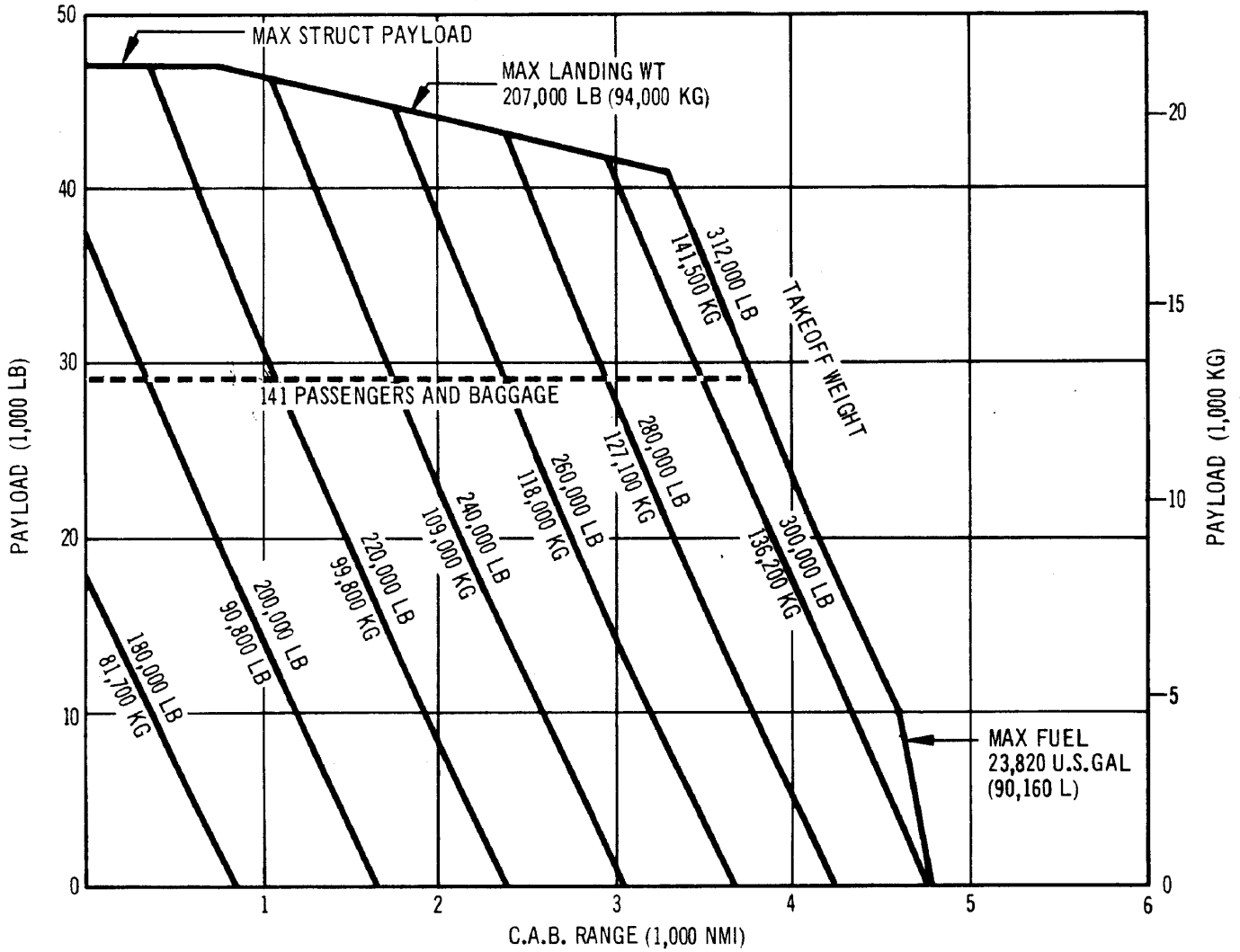

**PAYLOAD/RANGE FOR LONG RANGE STEP CLIMB CRUISE
MODEL 707-320 PASSENGER - INTERNATIONAL**

D6-58322

NOTES: ● OEW = 148,800 LB (67,500 KG), AN AVERAGE AIRLINE VALUE;
IF SPECIFIC FIGURES ARE REQUIRED, CONSULT USING AIRLINE.

● JT3D-3B (1C) ENGINES

● STANDARD DAY—ZERO WIND

● ATA INTERNATIONAL FUEL RESERVES – 200 NAUTICAL MILE ALTERNATE

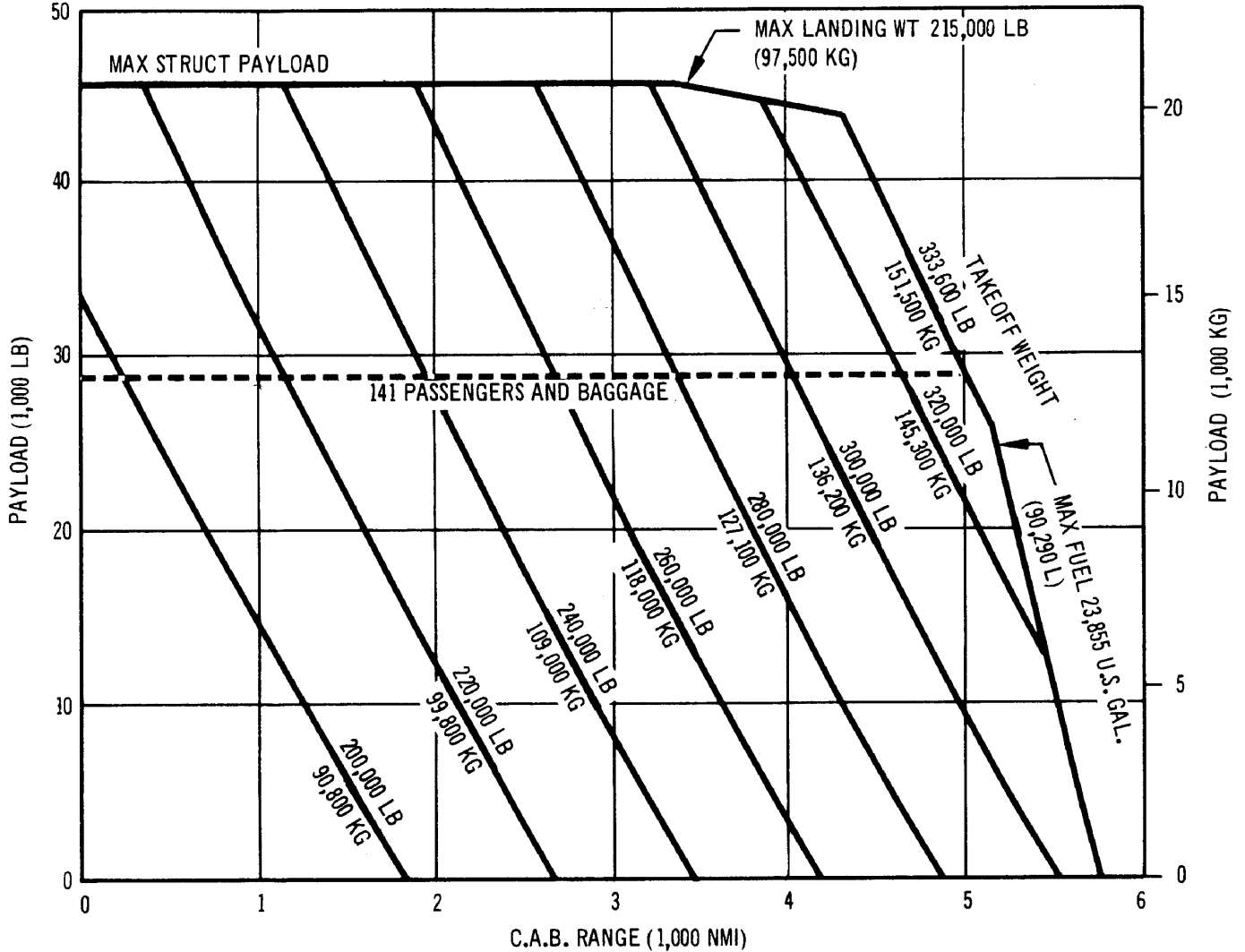

**PAYLOAD/RANGE FOR LONG RANGE STEP CLIMB CRUISE
MODEL 707-320B ADV PASSENGER - INTERNATIONAL**

NOTES: ● OEW = 148,300 LB (67,300 KG), AN AVERAGE AIRLINE VALUE;
IF SPECIFIC FIGURES ARE REQUIRED, CONSULT USING AIRLINE.

● JT3D-3B (IC) ENGINES

● STANDARD DAY - ZERO WIND

● ATA INTERNATIONAL FUEL RESERVES - 200 NAUTICAL MILE ALTERNATE

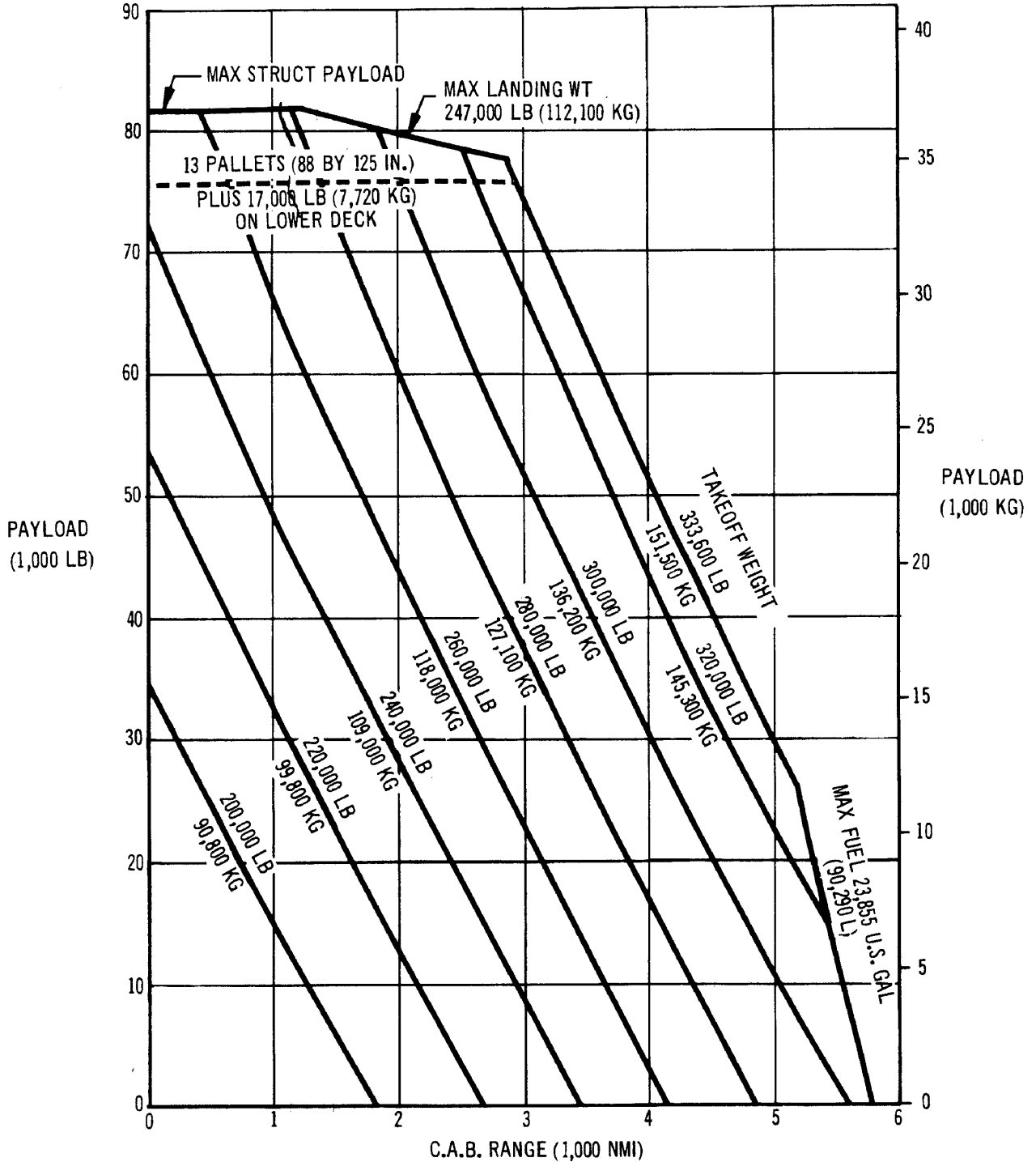

**PAYLOAD/RANGE FOR LONG RANGE STEP CLIMB CRUISE
MODEL 707-320C CONVERTIBLE -ALL CARGO- INTERNATIONAL**

- NOTES: ● OEW = 142,600 LB (64,600 KG), AN AVERAGE AIRLINE VALUE;
IF SPECIFIC FIGURES ARE REQUIRED, CONSULT USING AIRLINE.
- R. CO. - 12 ENGINES
- STANDARD DAY - ZERO WIND
- ATA INTERNATIONAL FUEL RESERVES - 200 NAUTICAL MILE ALTERNATE

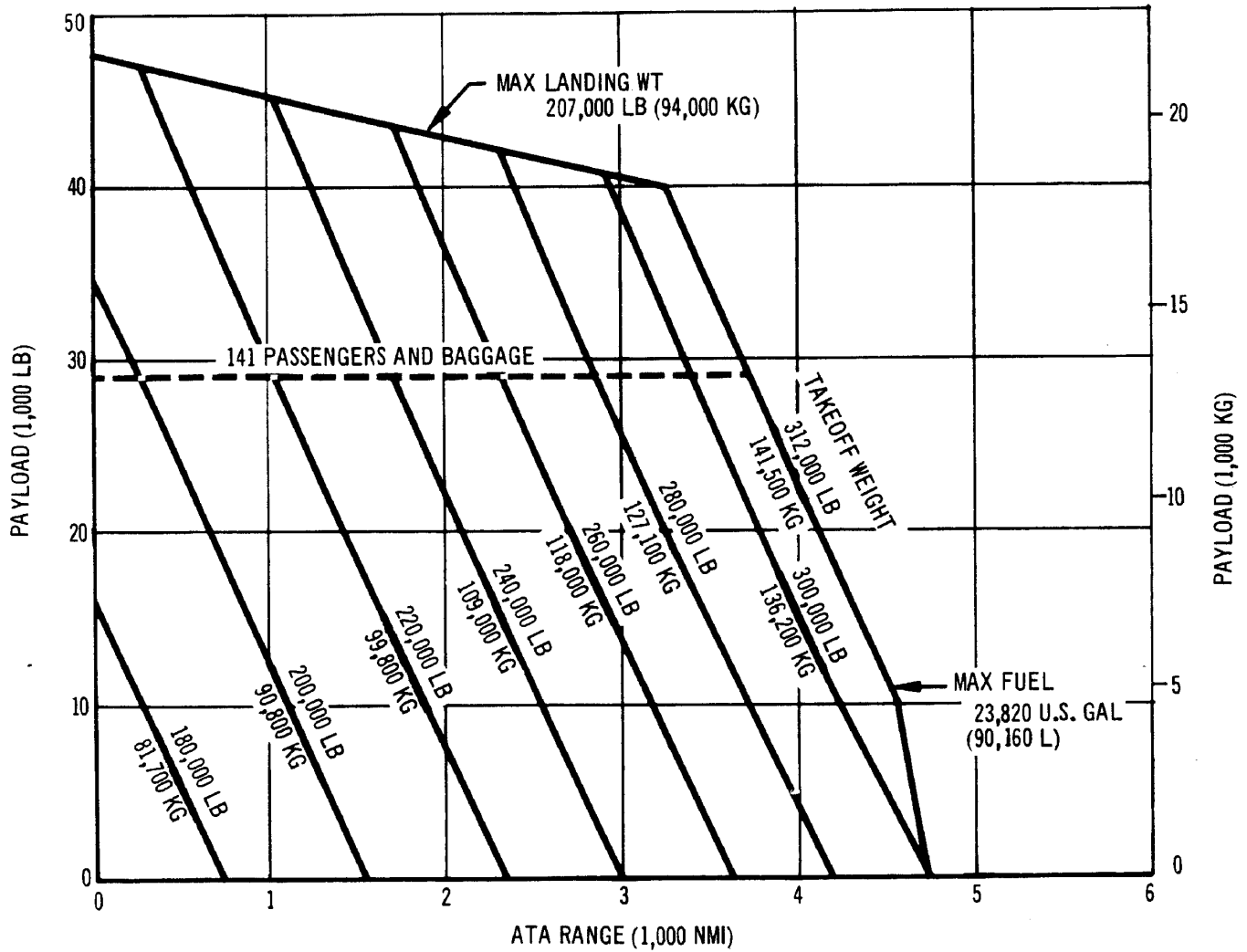

**PAYLOAD/RANGE FOR LONG RANGE STEP CLIMB CRUISE
MODEL 707-420 PASSENGER - INTERNATIONAL**

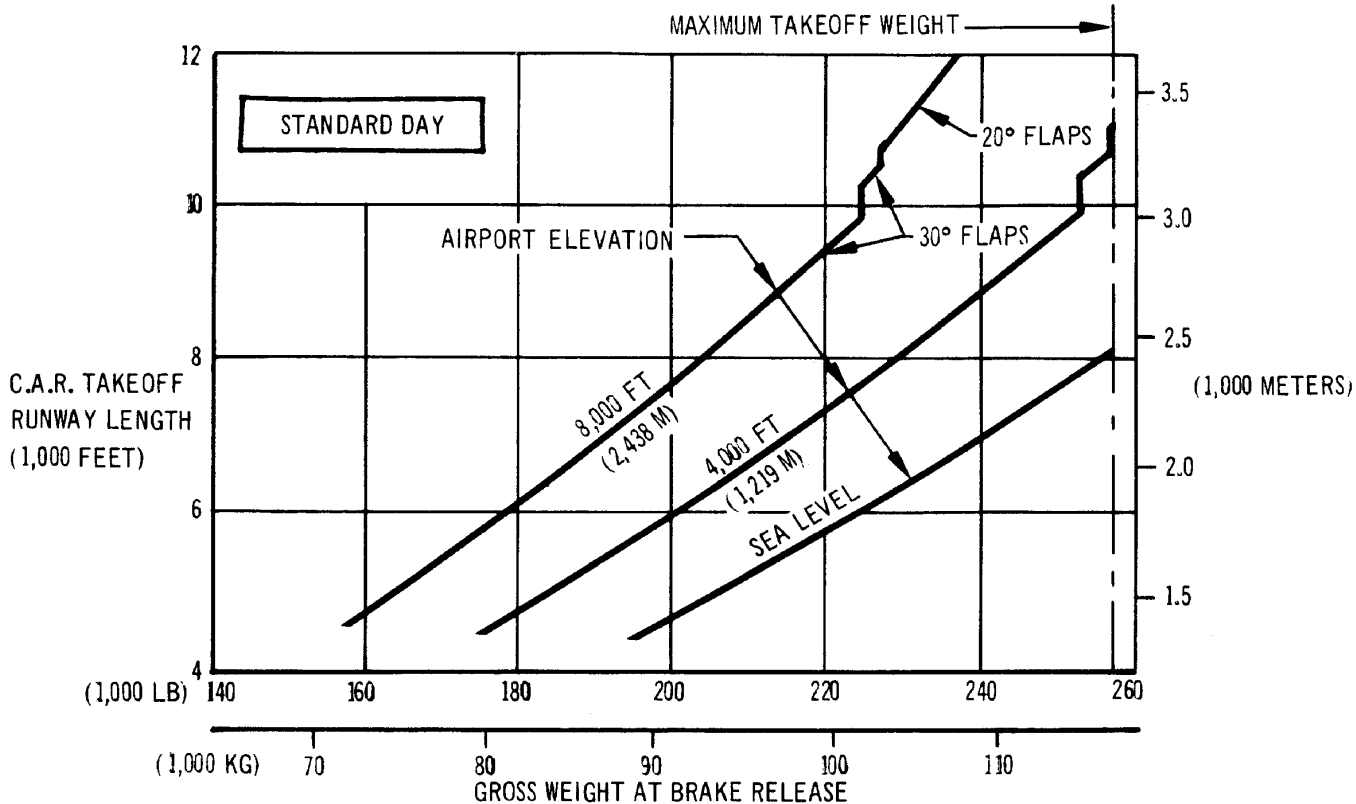

- NOTES:
- JT3D-1 ENGINES (DRY), TWO TURBOCOMPRESSORS ON
 - TAKEOFF NET THRUST = 17,000 LB (7,718 KG) SEA LEVEL STATIC RATING
 - ZERO RUNWAY GRADIENT
 - CONSULT USING AIRLINE FOR SPECIFIC OPERATING PROCEDURE PRIOR TO FACILITY DESIGN

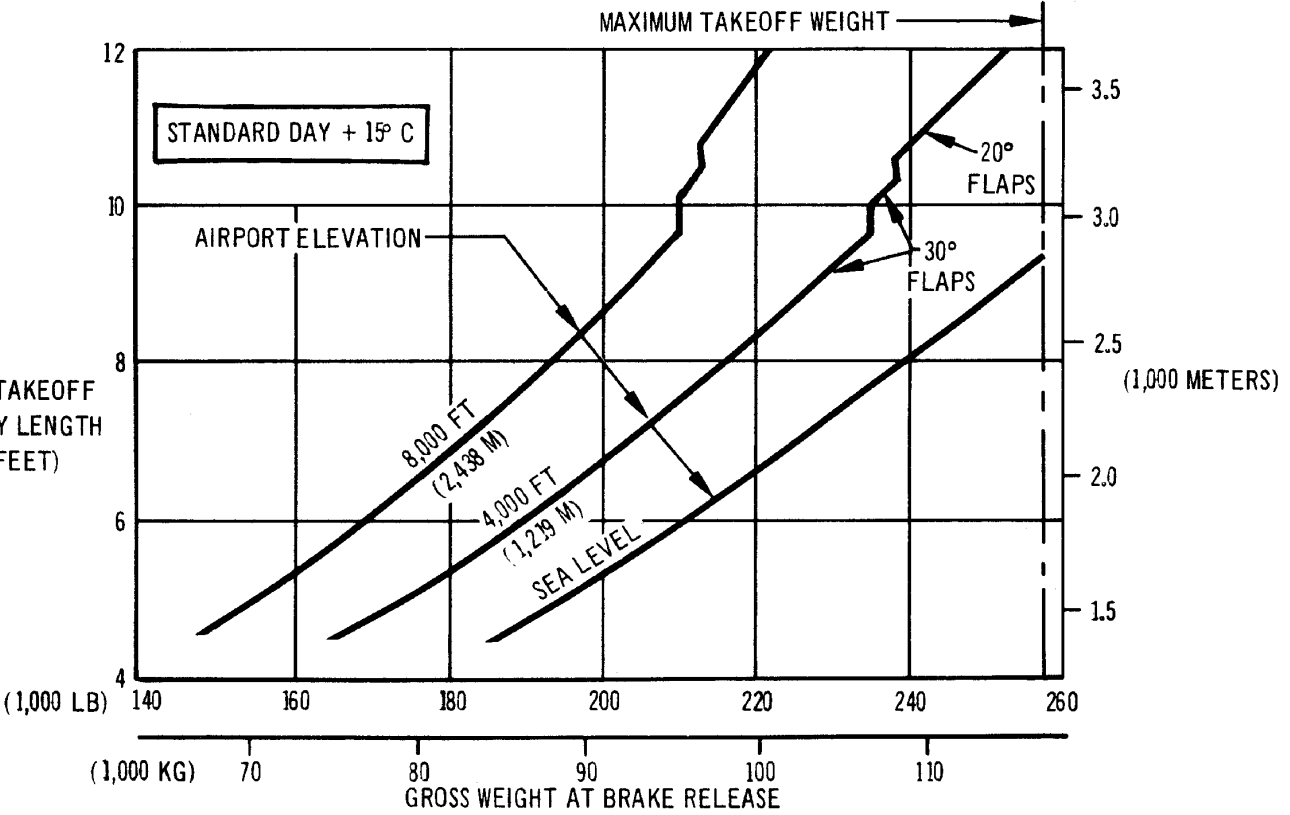

**3.2 C.A.R. TAKEOFF RUNWAY LENGTH REQUIREMENTS
MODEL 707-120B (JT3D-1 ENGINE)**

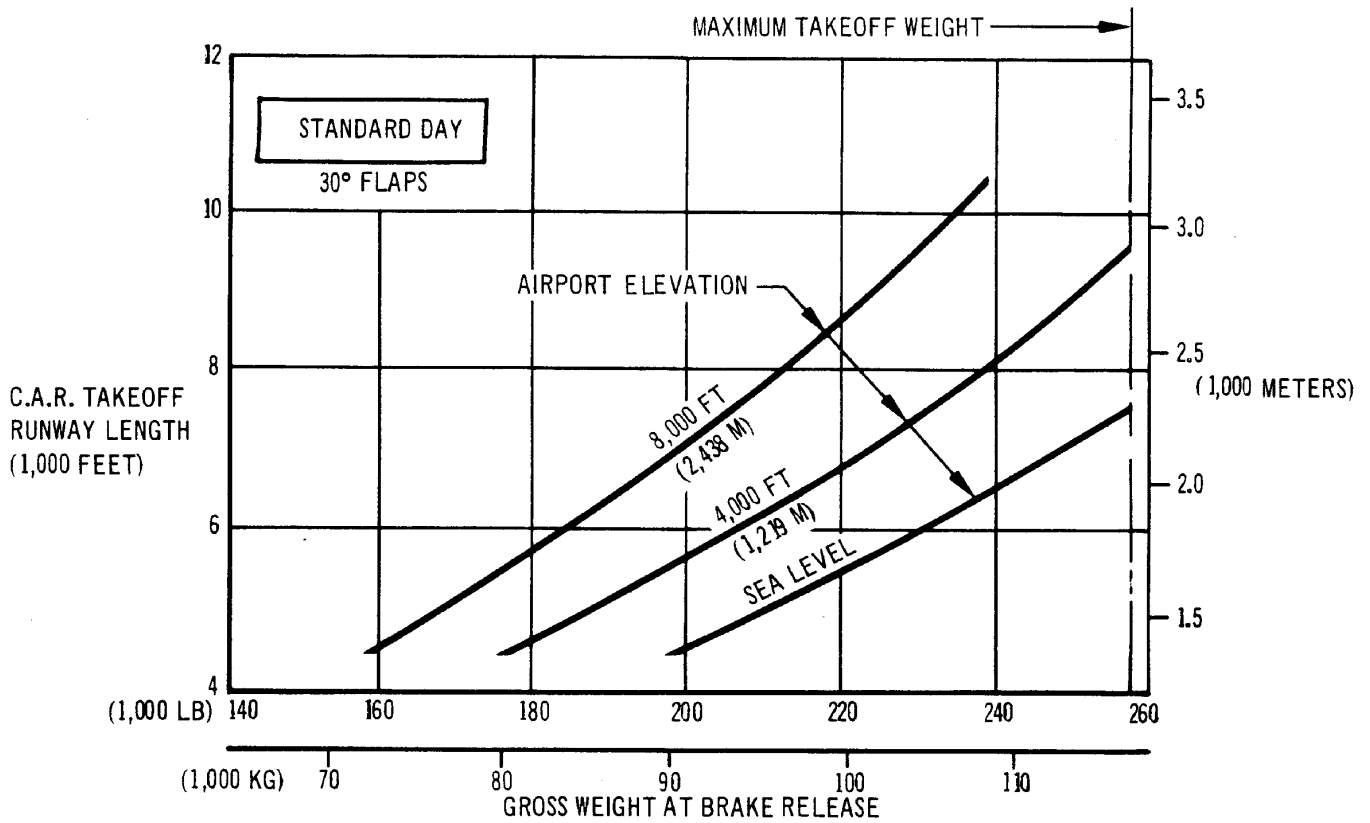

- NOTES:
- JT3D-3 ENGINES (DRY), TWO TURBOCOMPRESSORS ON
 - TAKEOFF NET THRUST = 18,000 LB (8,172 KG) SEA LEVEL STATIC RATING
 - ZERO RUNWAY GRADIENT
 - CONSULT USING AIRLINE FOR SPECIFIC OPERATING PROCEDURE PRIOR TO FACILITY DESIGN

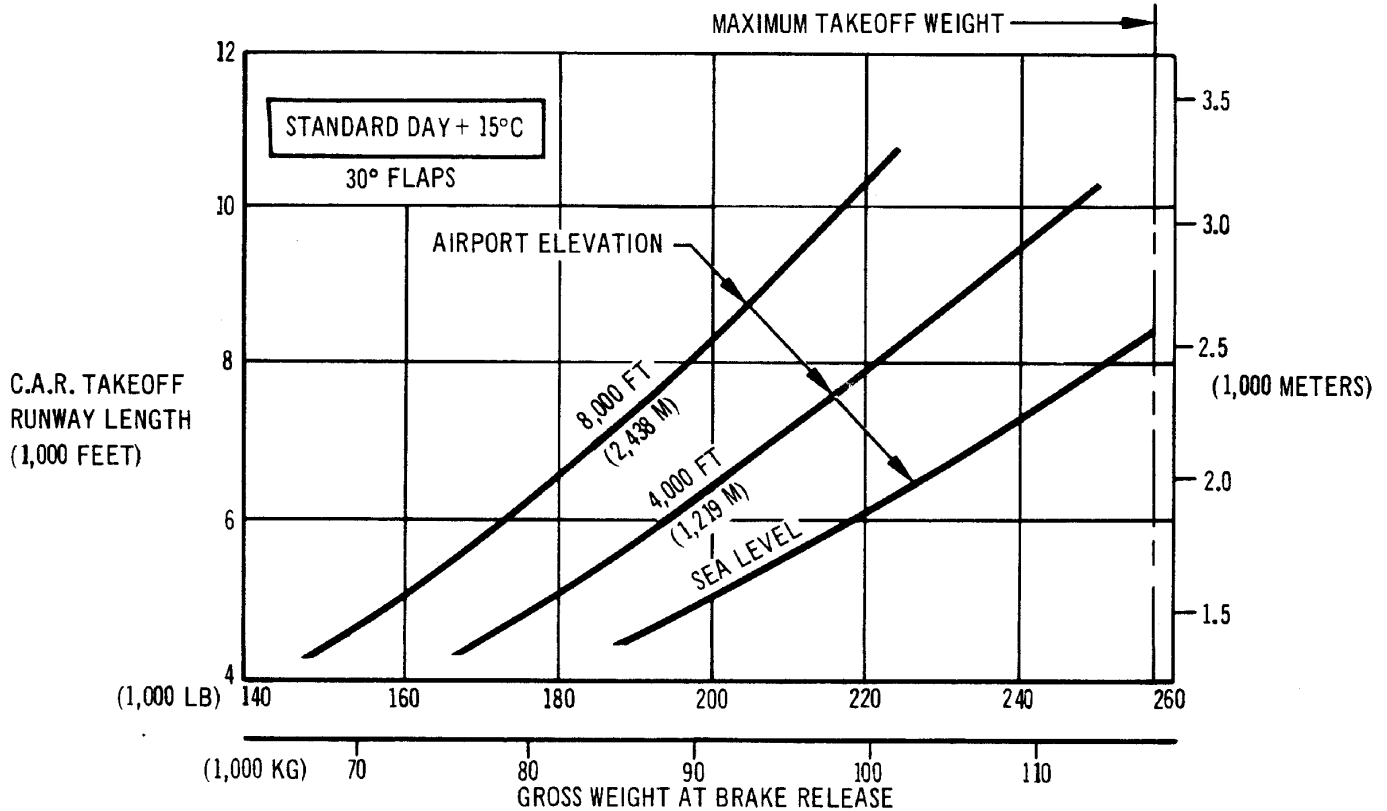

**C.A.R. TAKEOFF RUNWAY LENGTH REQUIREMENTS
MODEL 707-120B (JT3D-3 ENGINE)**

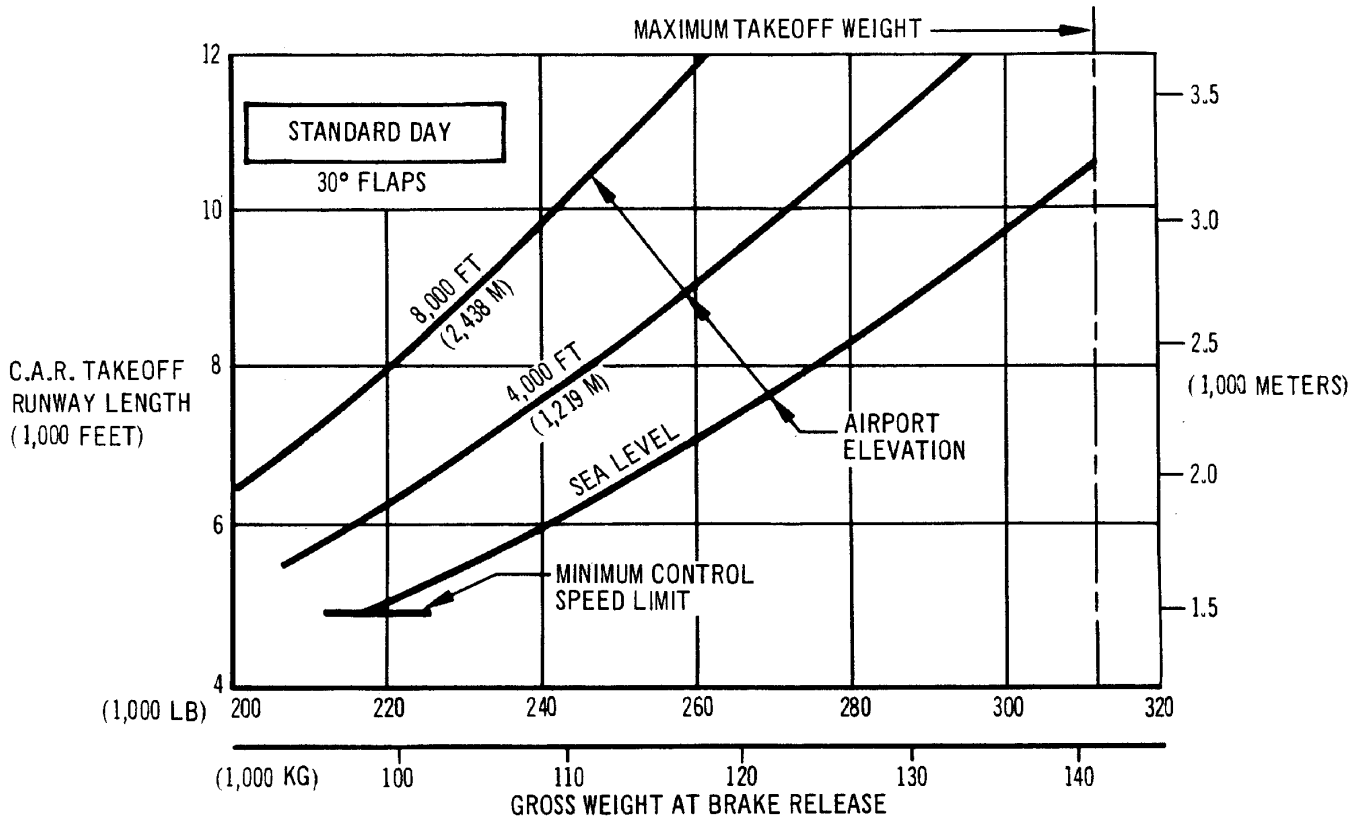

- NOTES:
- JT4A-11, -12 ENGINES (FULL RATED), ONE TURBOCOMPRESSOR ON
 - TAKEOFF NET THRUST = 17,500 LB (7,945 KG) SEA LEVEL STATIC RATING
 - ZERO RUNWAY GRADIENT
 - CONSULT USING AIRLINE FOR SPECIFIC OPERATING PROCEDURE PRIOR TO FACILITY DESIGN

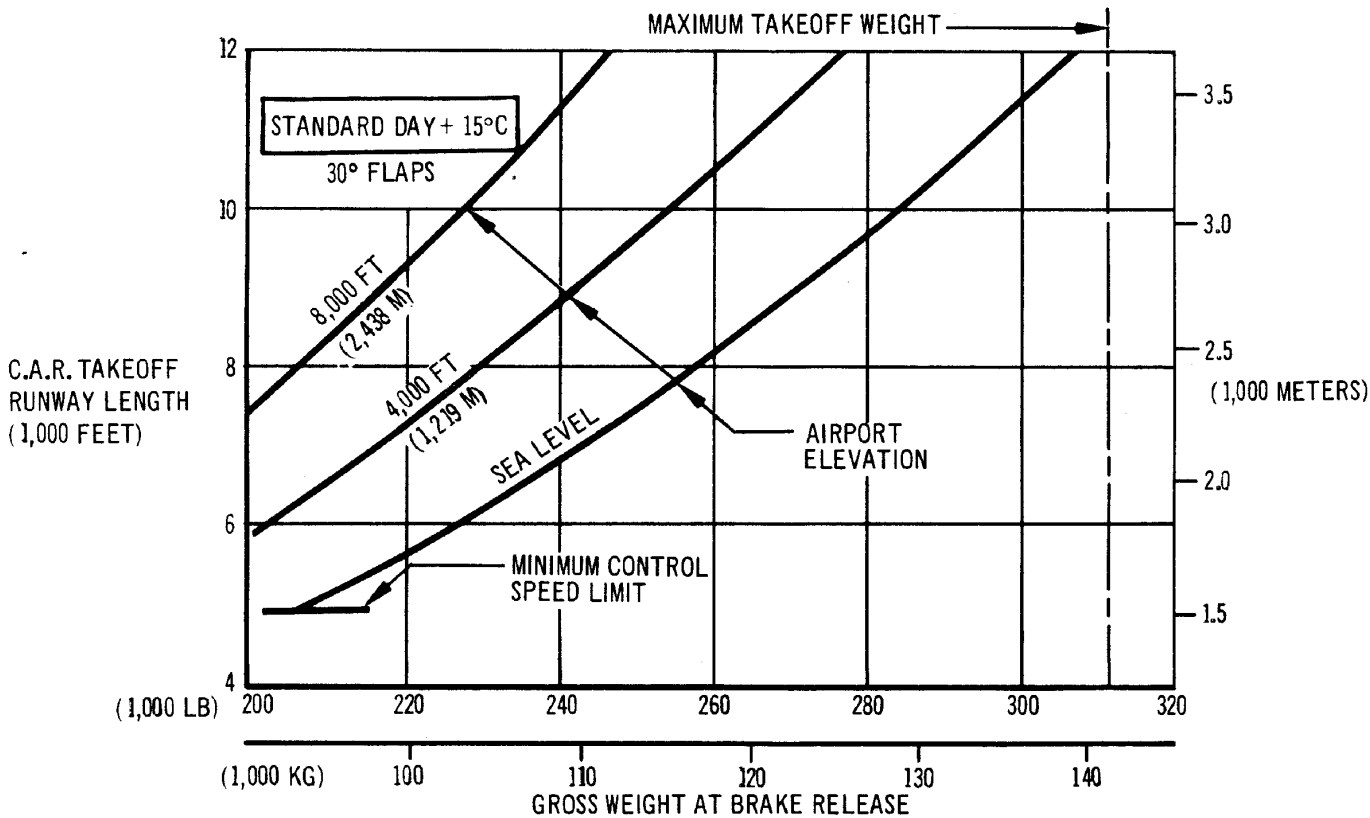

**C.A.R. TAKE OFF RUNWAY LENGTH REQUIREMENTS
MODEL 707-320 (JT4A-11, -12 ENGINES)**

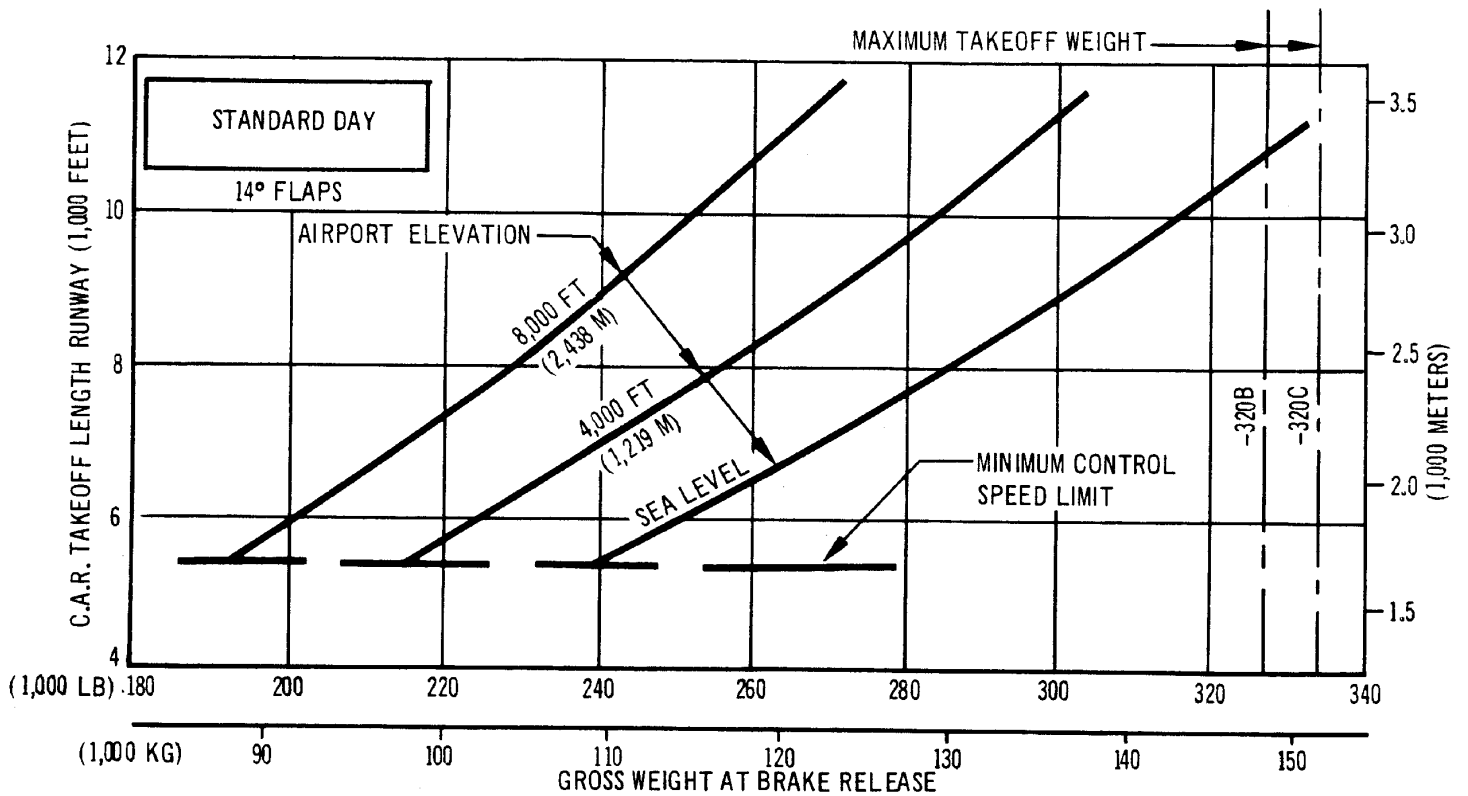

- NOTES:
- JT3D-3B ENGINES -EXT TEMP (DRY) - SMALL COWL DOOR, TURBOCOMPRESSORS OFF
 - TAKEOFF NET THRUST = 18,000 LB (8,172 KG) SEA LEVEL STATIC RATING
 - ZERO RUNWAY GRADIENT
 - CONSULT USING AIRLINE FOR SPECIFIC OPERATING PROCEDURE PRIOR TO FACILITY DESIGN

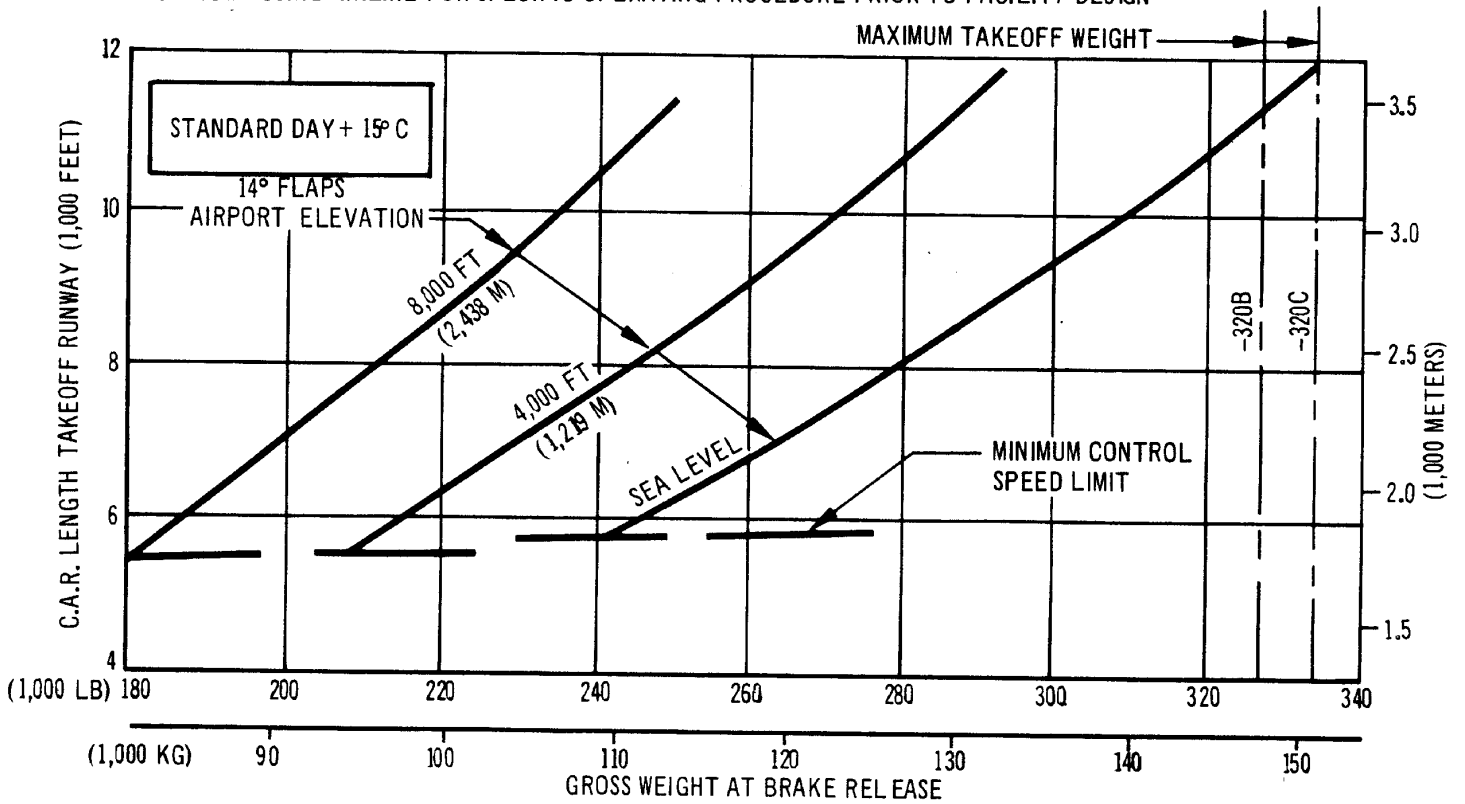

**C.A.R. TAKEOFF RUNWAY LENGTH REQUIREMENTS
MODELS 707-320B ADVANCED, -320C (JT3D-3B ENGINES - SMALL COWL DOORS)**

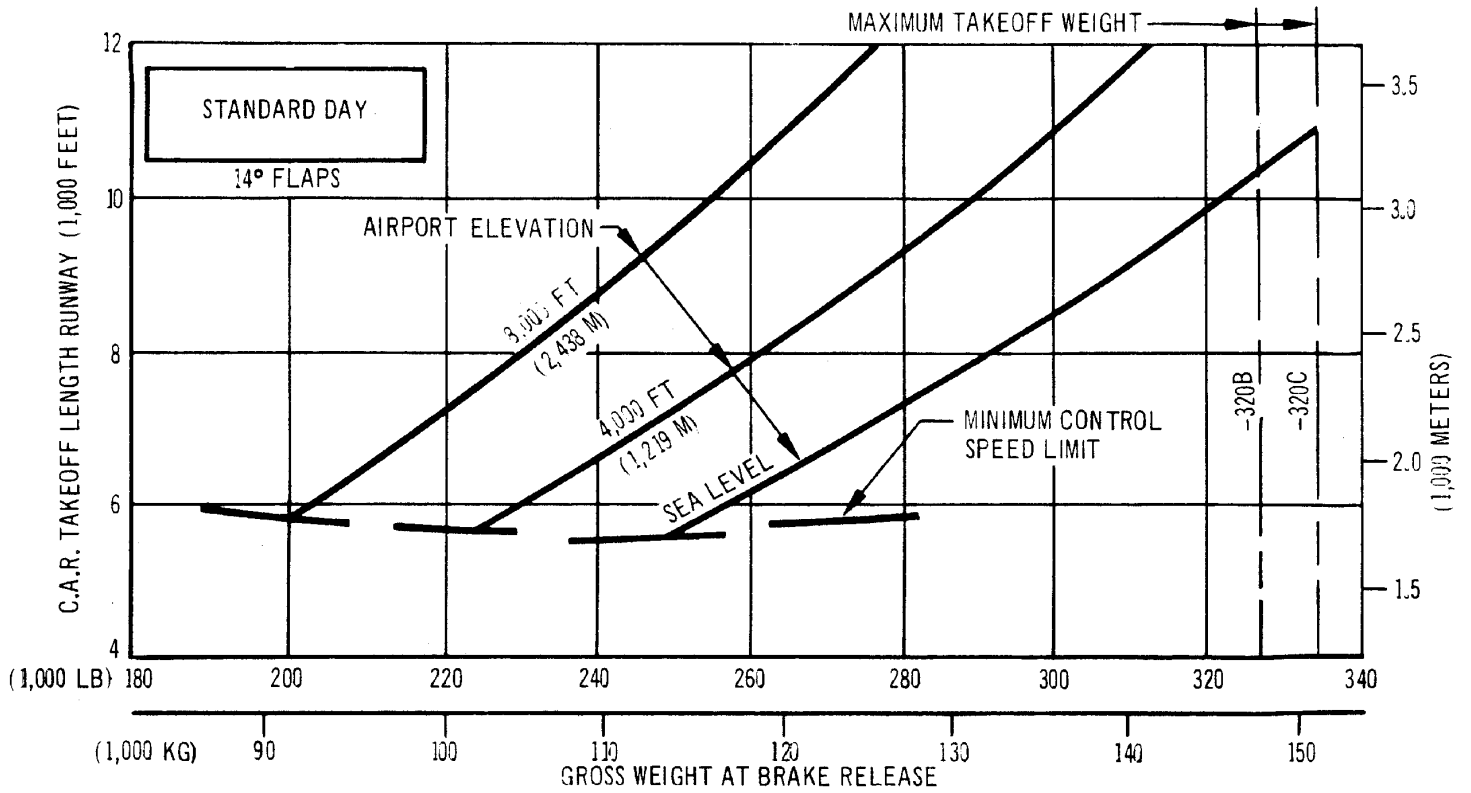

- NOTES:
- JT3D-3B ENGINES (DRY) - IMPROVED COWL DOORS, TURBOCOMPRESSORS OFF
 - TAKEOFF NET THRUST = 18,000 LB (8,172 KG) SEA LEVEL STATIC RATING
 - ZERO RUNWAY GRADIENT
 - CONSULT USING AIRLINE FOR SPECIFIC OPERATING PROCEDURE PRIOR TO FACILITY DESIGN

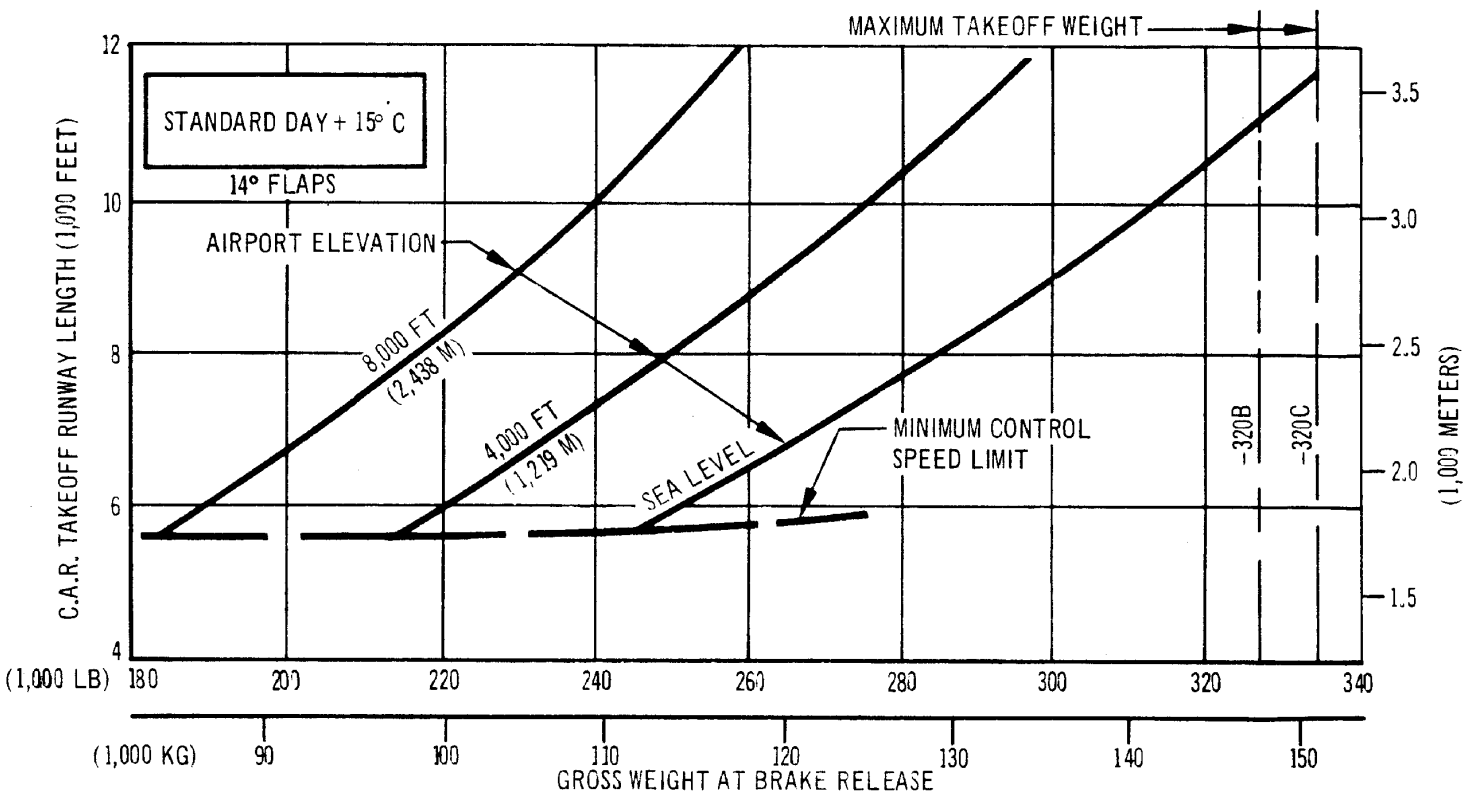

C.A.R. TAKE OFF RUNWAY LENGTH REQUIREMENTS
MODEL 707-320B ADVANCED, -320C (JT3D-3B ENGINES - IMPROVED COWL DOORS)

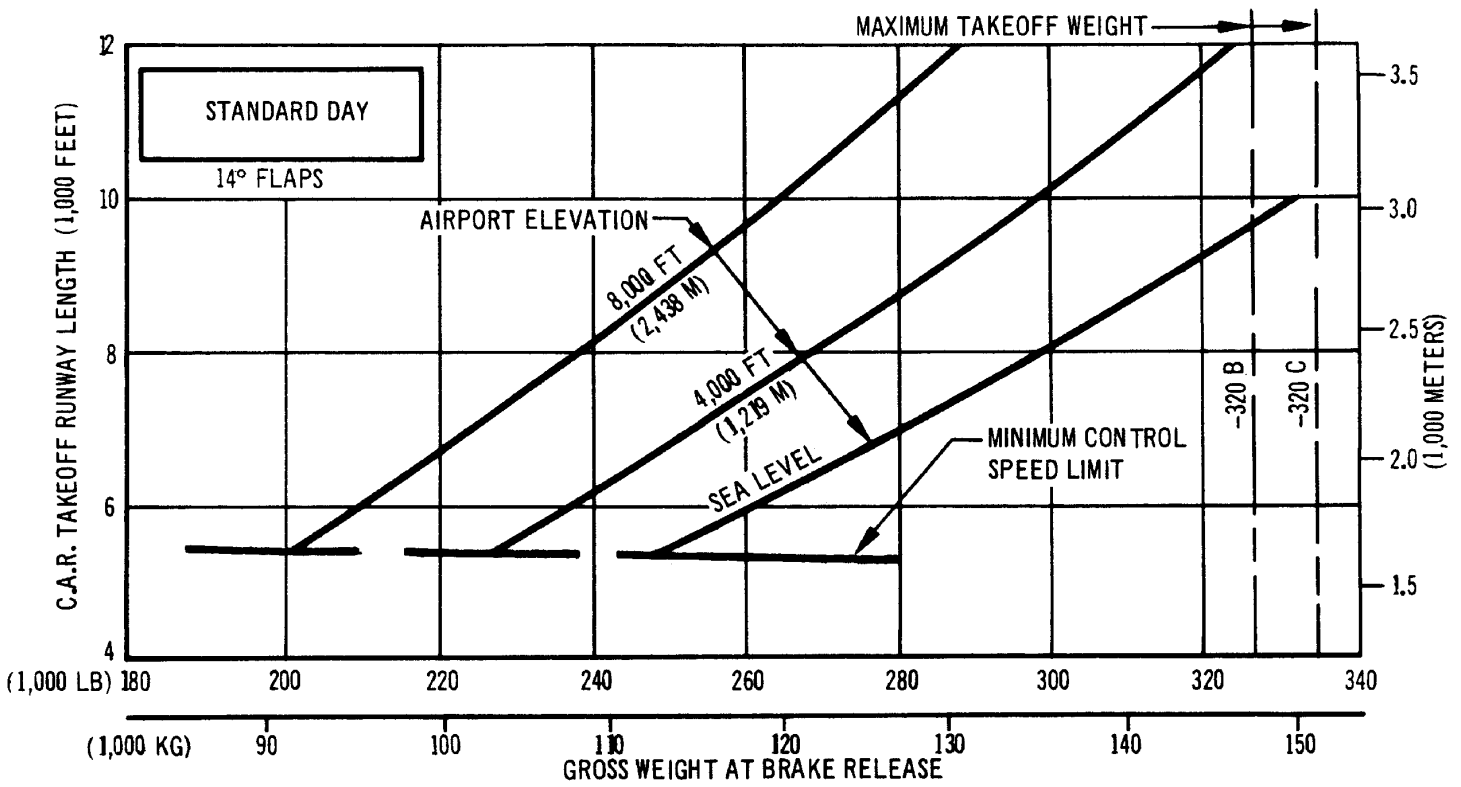

- NOTES:
- JT3D-7 ENGINES (DAY) - IMPROVED COWL DOORS, TURBOCOMPRESSORS OFF
 - TAKEOFF NET THRUST = 19,000 LB (8,626 KG) SEA LEVEL STATIC RATING
 - ZERO RUNWAY GRADIENT
 - CONSULT USING AIRLINE FOR SPECIFIC OPERATING PROCEDURE PRIOR TO FACILITY DESIGN

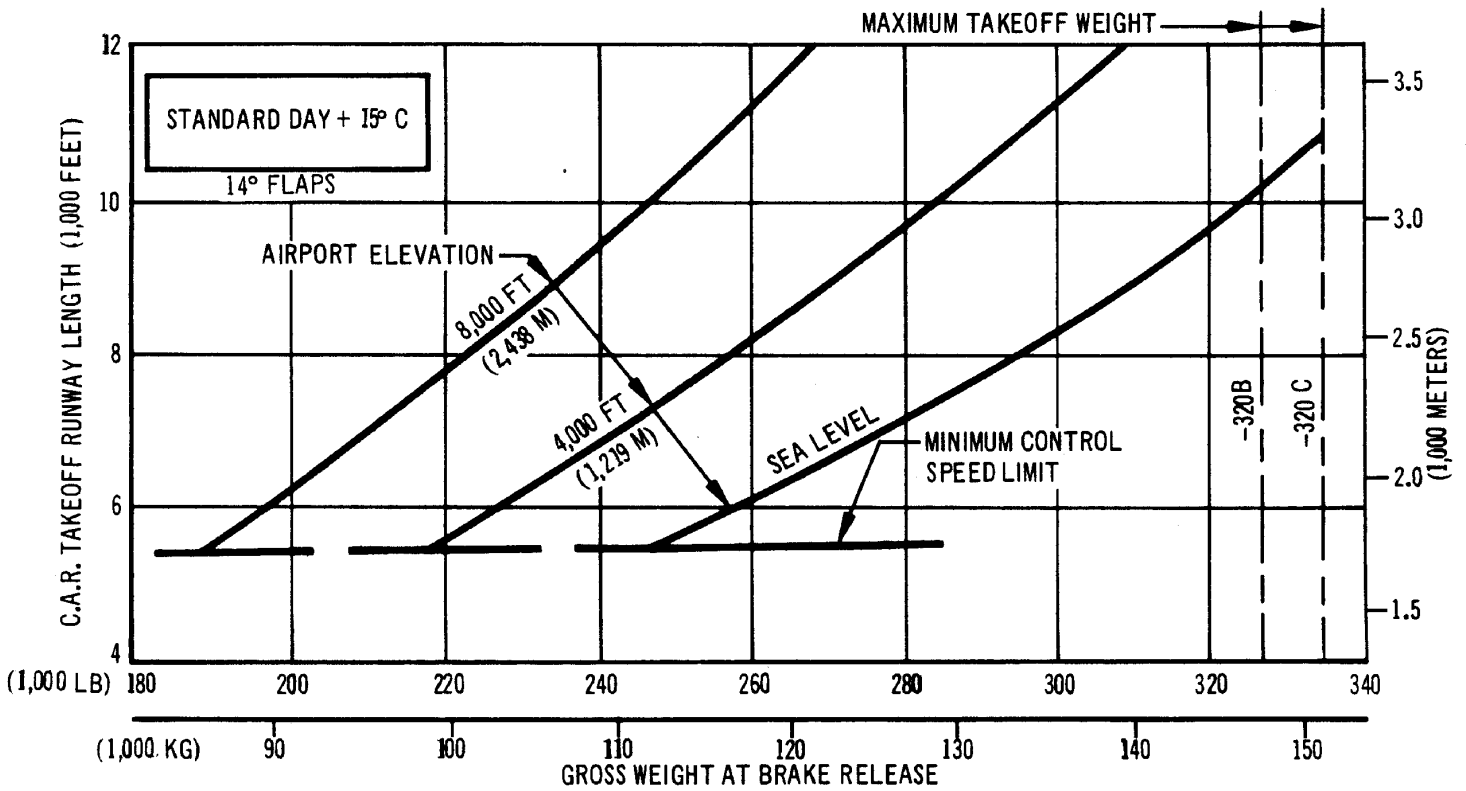

**C.A.R. TAKEOFF RUNWAY LENGTH REQUIREMENTS
MODELS 707-320B ADVANCED, -320C (JT3D-7 ENGINE - IMPROVED COWL DOORS)**

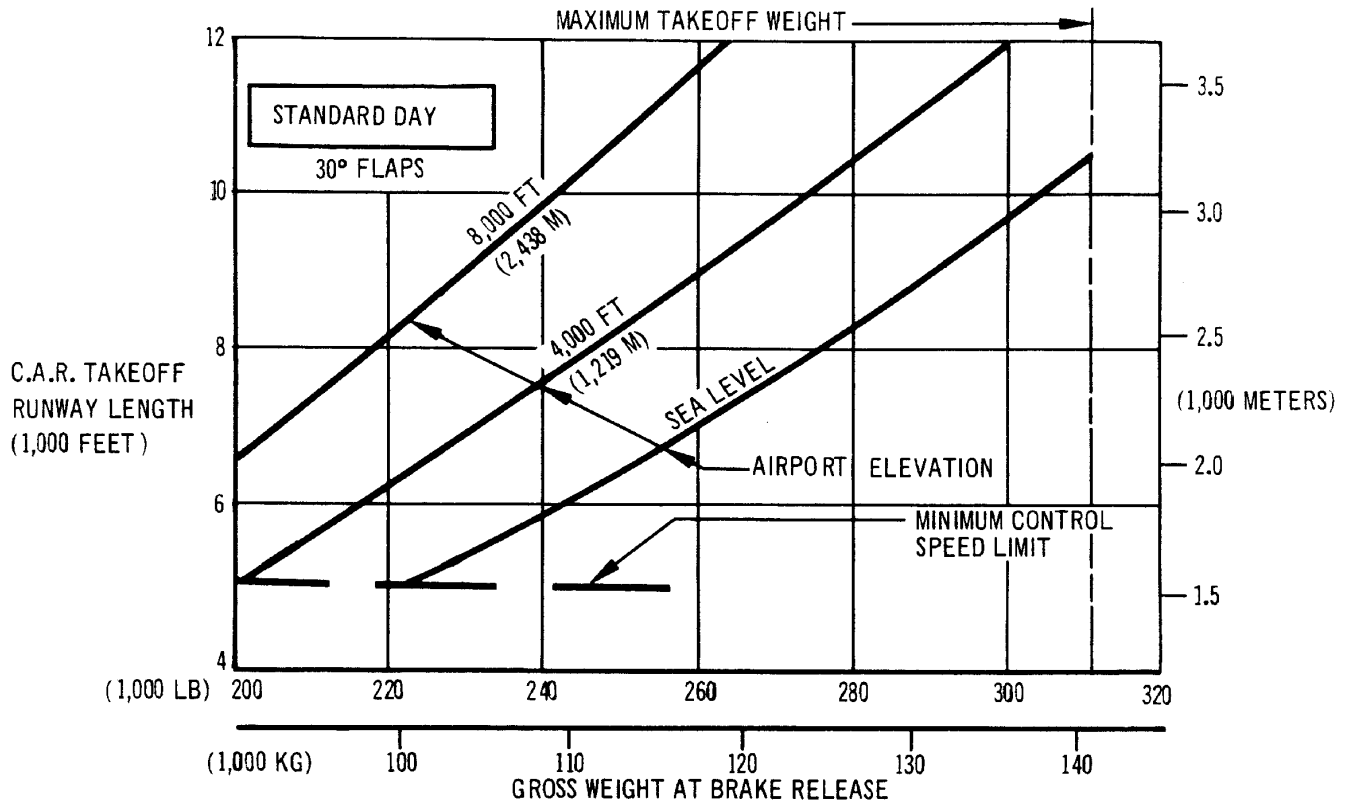

- NOTES:
- R.Co. - 12 ENGINES, ONE TURBOCOMPRESSOR ON
 - TAKEOFF NET THRUST = 17,500 LB (7,945 KG) SEA LEVEL STATIC RATING
 - ZERO RUNWAY GRADIENT
 - CONSULT USING AIRLINE FOR SPECIFIC OPERATING PROCEDURE PRIOR TO FACILITY DESIGN

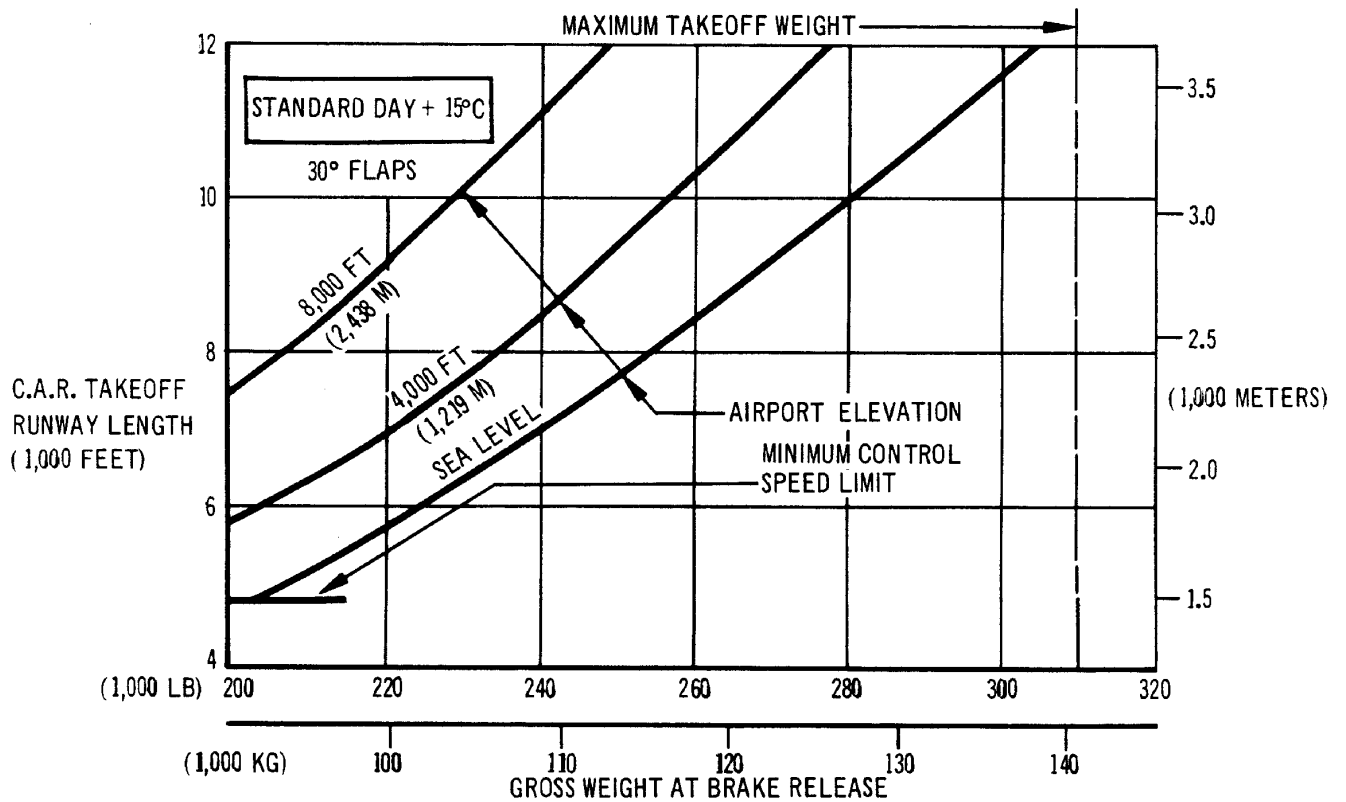

**C.A.R. TAKEOFF RUNWAY LENGTH REQUIREMENTS
MODEL 707-420**

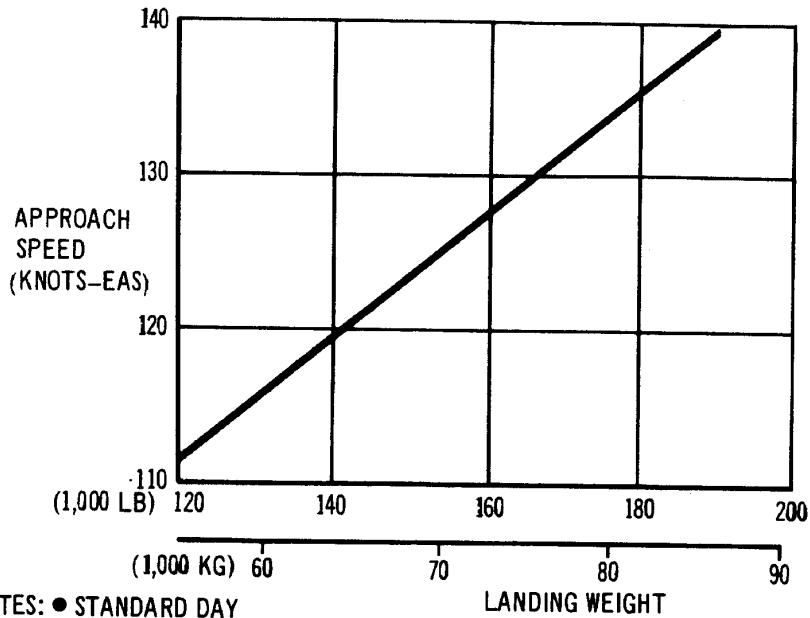

- NOTES:
- STANDARD DAY
 - ZERO RUNWAY GRADIENT
 - CONSULT USING AIRLINE FOR SPECIFIC OPERATING PROCEDURE PRIOR TO FACILITY DESIGN

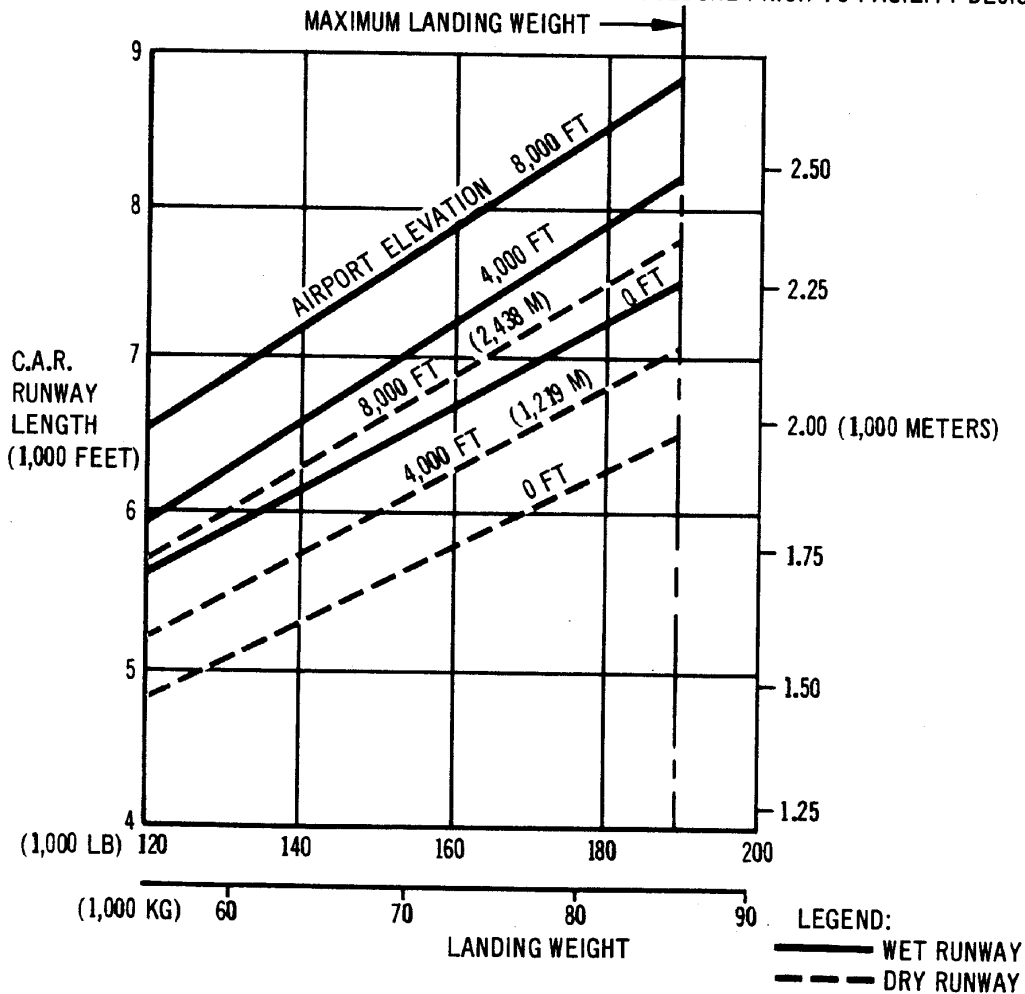

3.3 C.A.R. LANDING RUNWAY LENGTH REQUIREMENTS MODEL 707-120B

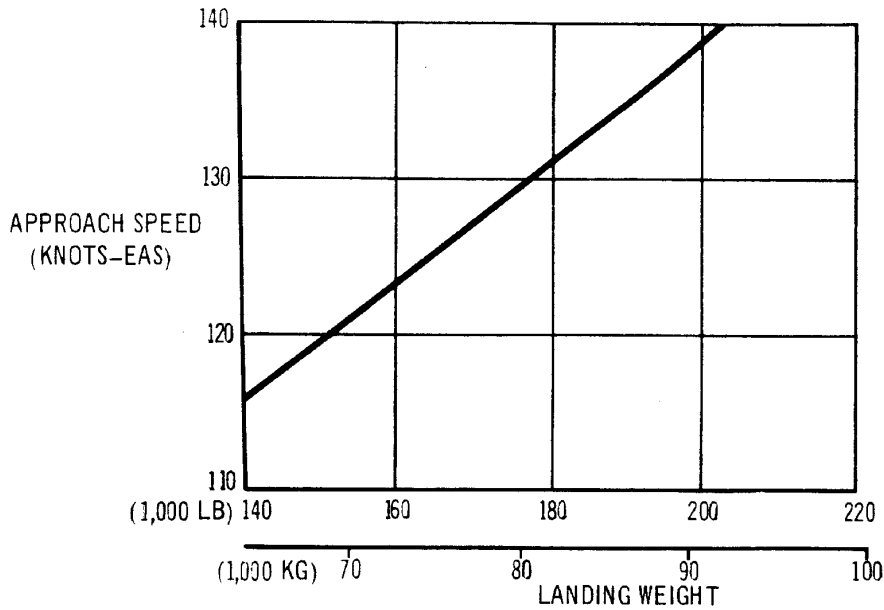

- NOTES:
- STANDARD DAY
 - ZERO RUNWAY GRADIENT
 - CONSULT USING AIRLINE FOR SPECIFIC OPERATING PROCEDURE PRIOR TO FACILITY DESIGN

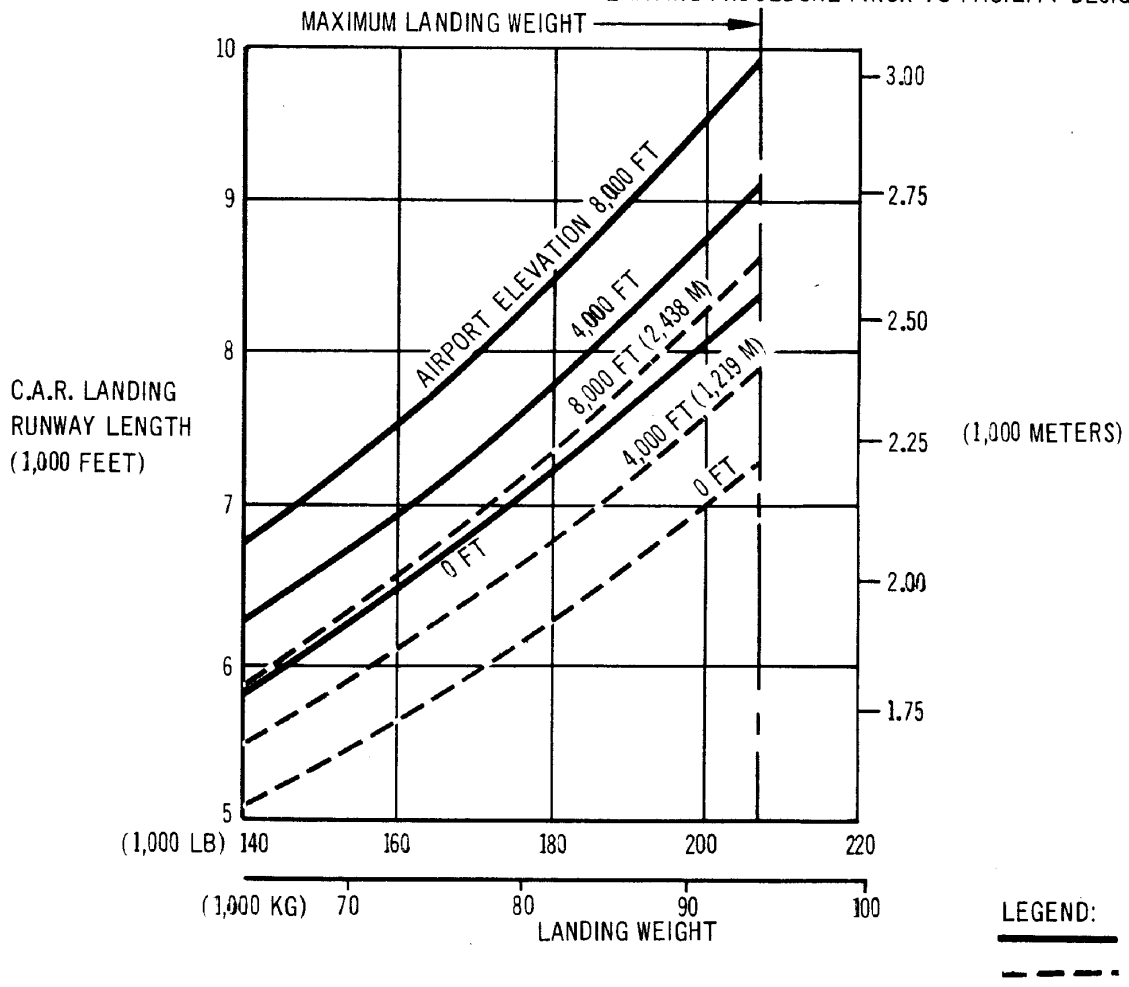

**C.A.R. LANDING RUNWAY LENGTH REQUIREMENTS
MODEL 707-320**

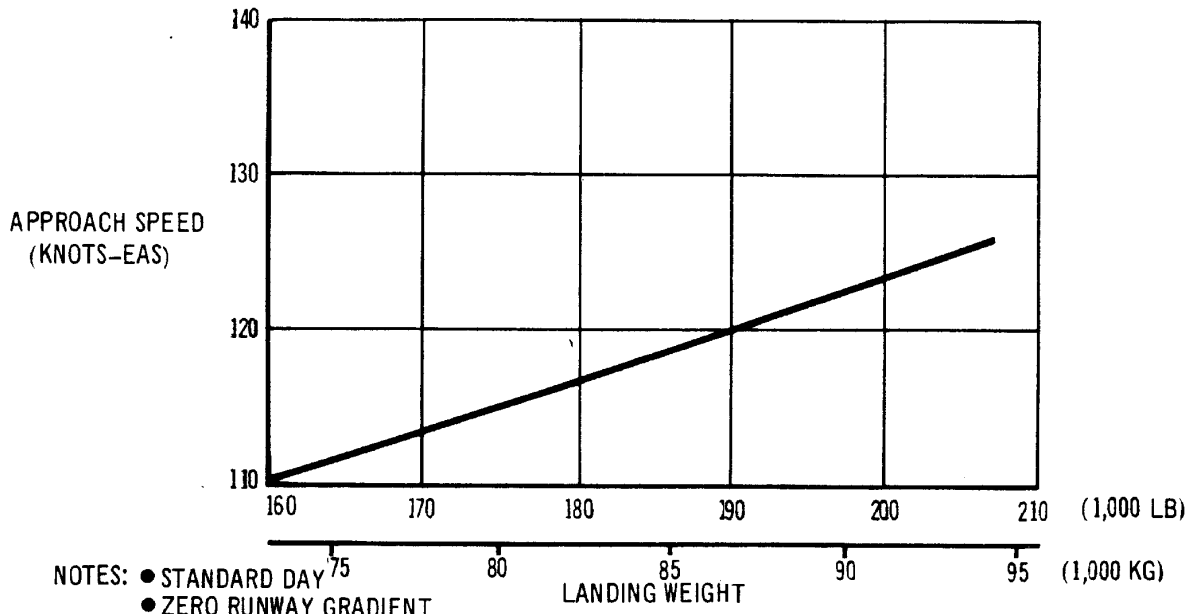

- NOTES:
- STANDARD DAY
 - ZERO RUNWAY GRADIENT
 - GOODRICH BRAKES WITH TANDEM PAIRED MARK II ANTISKID SYSTEMS
 - CONSULT USING AIRLINE FOR SPECIFIC OPERATING PROCEDURE PRIOR TO FACILITY DESIGN

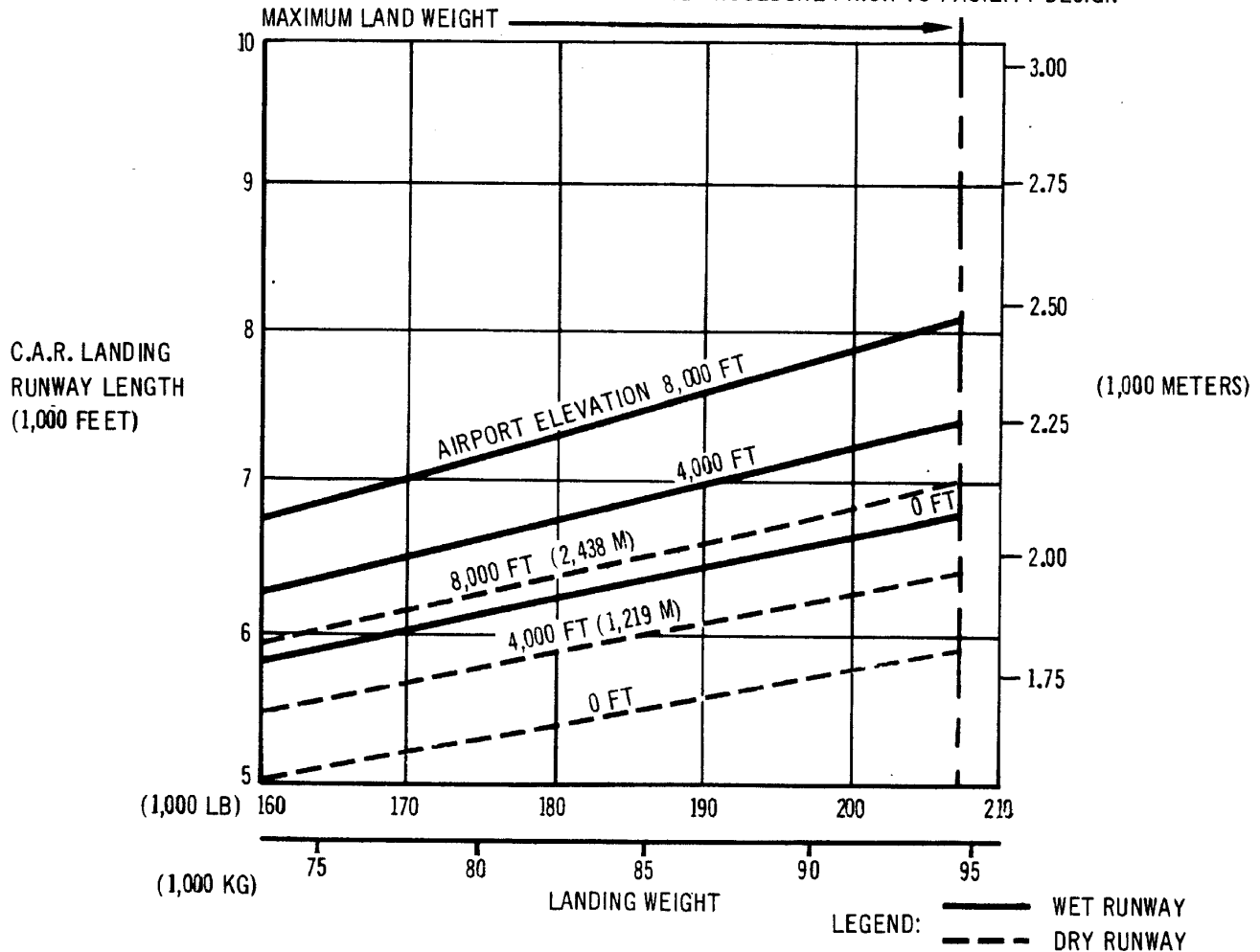

**C.A.R. LANDING RUNWAY LENGTH REQUIREMENTS
MODEL 707-320B ADVANCED**

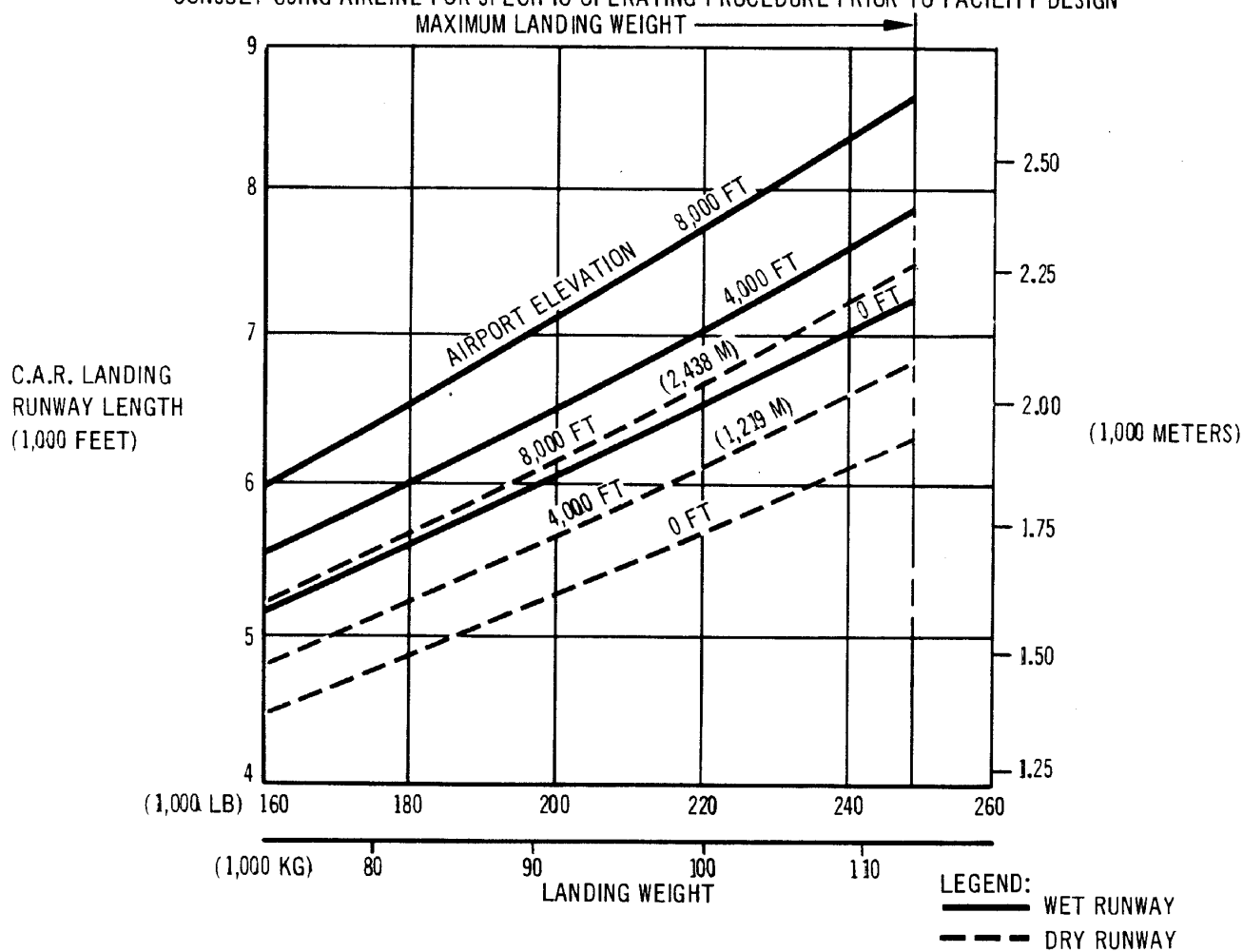
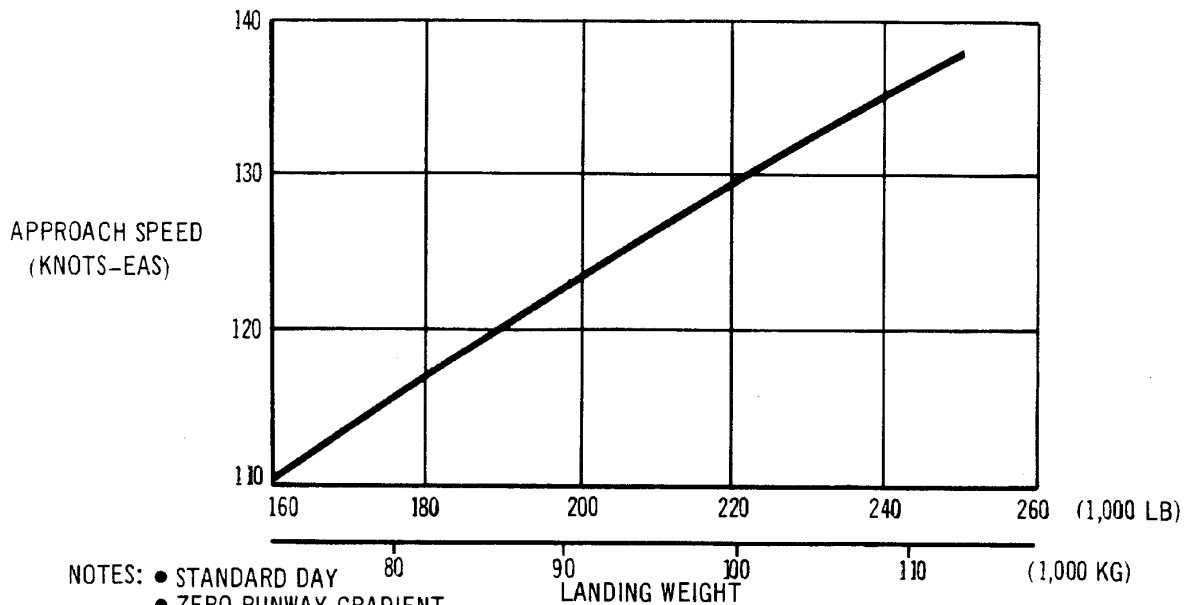

**C.A.R. LANDING RUNWAY LENGTH REQUIREMENTS
MODEL 707-320C**

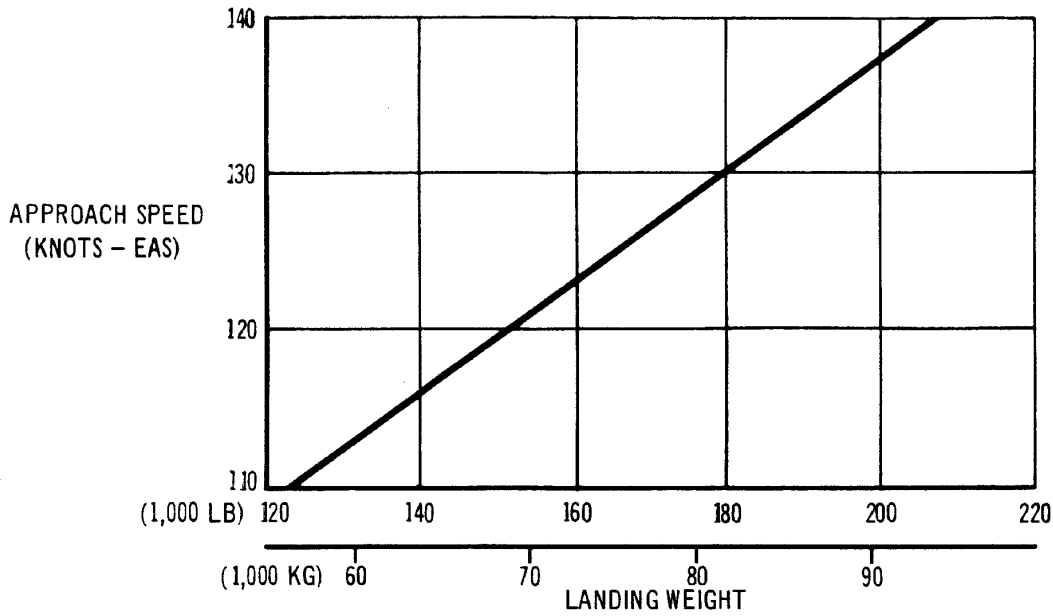

- NOTES:
- STANDARD DAY
 - ZERO RUNWAY GRADIENT
 - CONSULT USING AIRLINE FOR SPECIFIC OPERATING PROCEDURE PRIOR TO FACILITY DESIGN

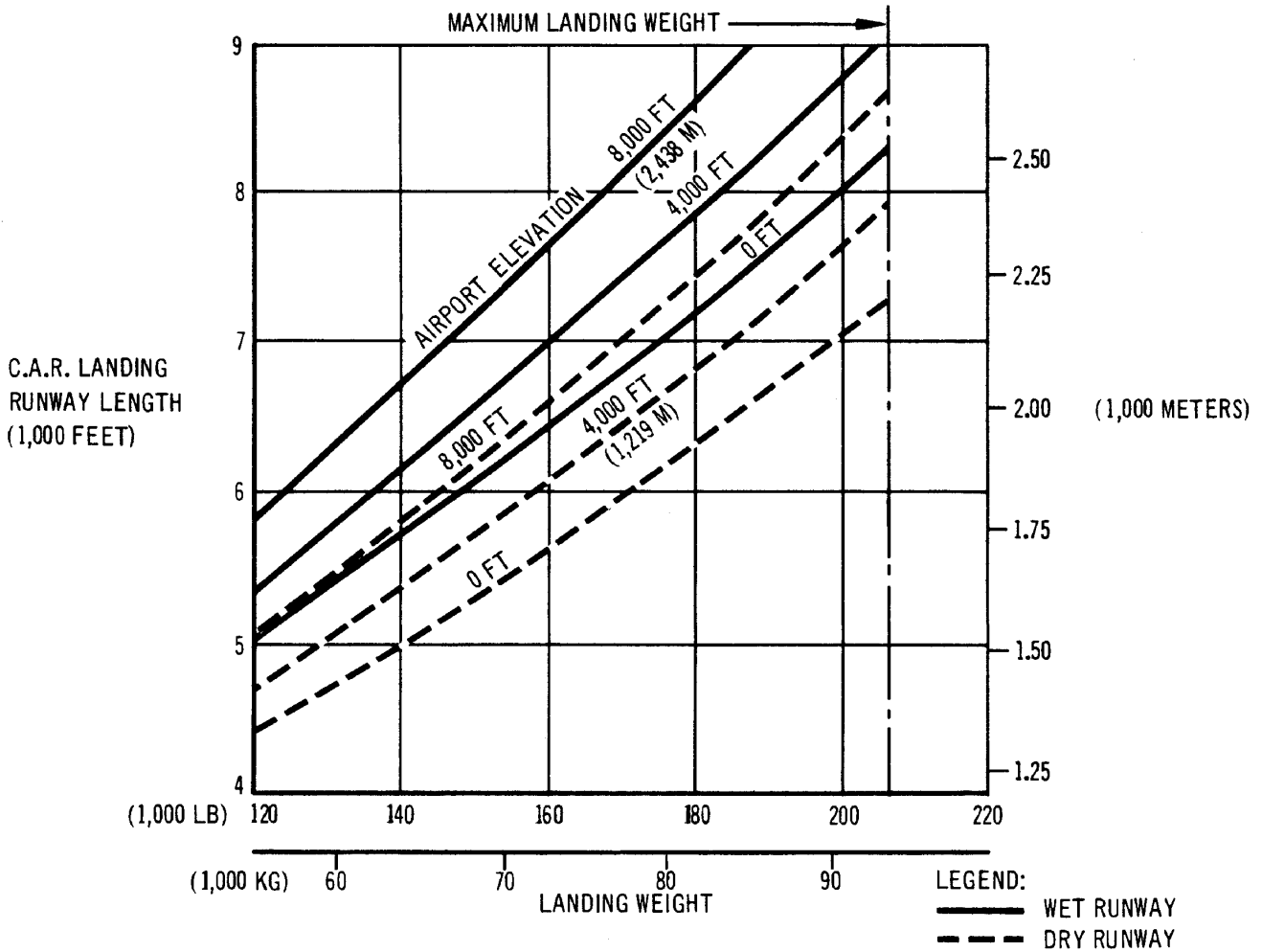

**C.A.R. LANDING RUNWAY LENGTH REQUIREMENTS
MODEL 707-420**

4.0 GROUND MANEUVERING

4.1 Turning Radii

4.2 Runway and Taxiway Turn Paths

4.3 Runway Holding Apron

4.4 Minimum Parking Space Requirements

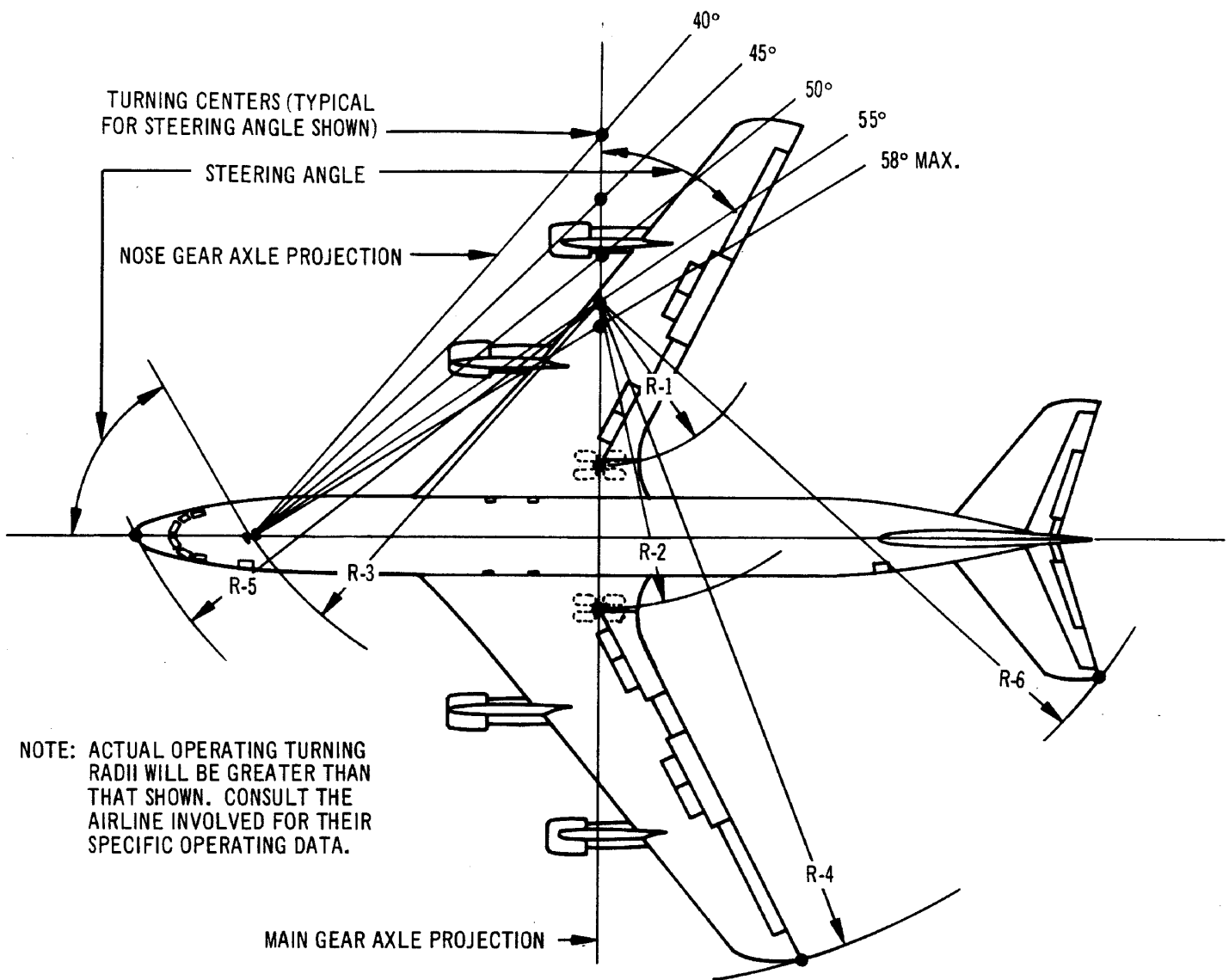

NOTE: ACTUAL OPERATING TURNING RADII WILL BE GREATER THAN THAT SHOWN. CONSULT THE AIRLINE INVOLVED FOR THEIR SPECIFIC OPERATING DATA.

DIMENSIONS ROUNDED TO NEAREST FOOT AND 0.1 METER

STEERING ANGLE (DEGREES)	R-1		R-2		R-3		R-4		R-5		R-6	
	INNER GEAR		OUTER GEAR		NOSE GEAR		WING TIP		NOSE		TAIL	
	FT	M	FT	M	FT	M	FT	M	FT	M	FT	M
30	80	24.4	102	31.1	105	32	159	48.5	114	34.7	136	41.5
35	64	19.5	86	26.2	91	27.7	143	43.6	102	31.1	123	37.5
40	51	15.5	73	22.3	82	25	132	40.2	94	28.7	113	34.4
45	41	12.5	63	19.2	74	22.6	122	37.2	87	26.5	105	32
50	33	10	55	16.8	68	20.7	113	34.4	82	25	100	30.5
55	26	7.9	48	14.6	65	19.8	107	32.6	79	24.1	95	29
58 MAX	22	6.7	44	13.4	63	19.2	103	31.4	77	23.5	90	27.4

4.1 TURNING RADII - NO SLIP ANGLE
MODEL 707-120B

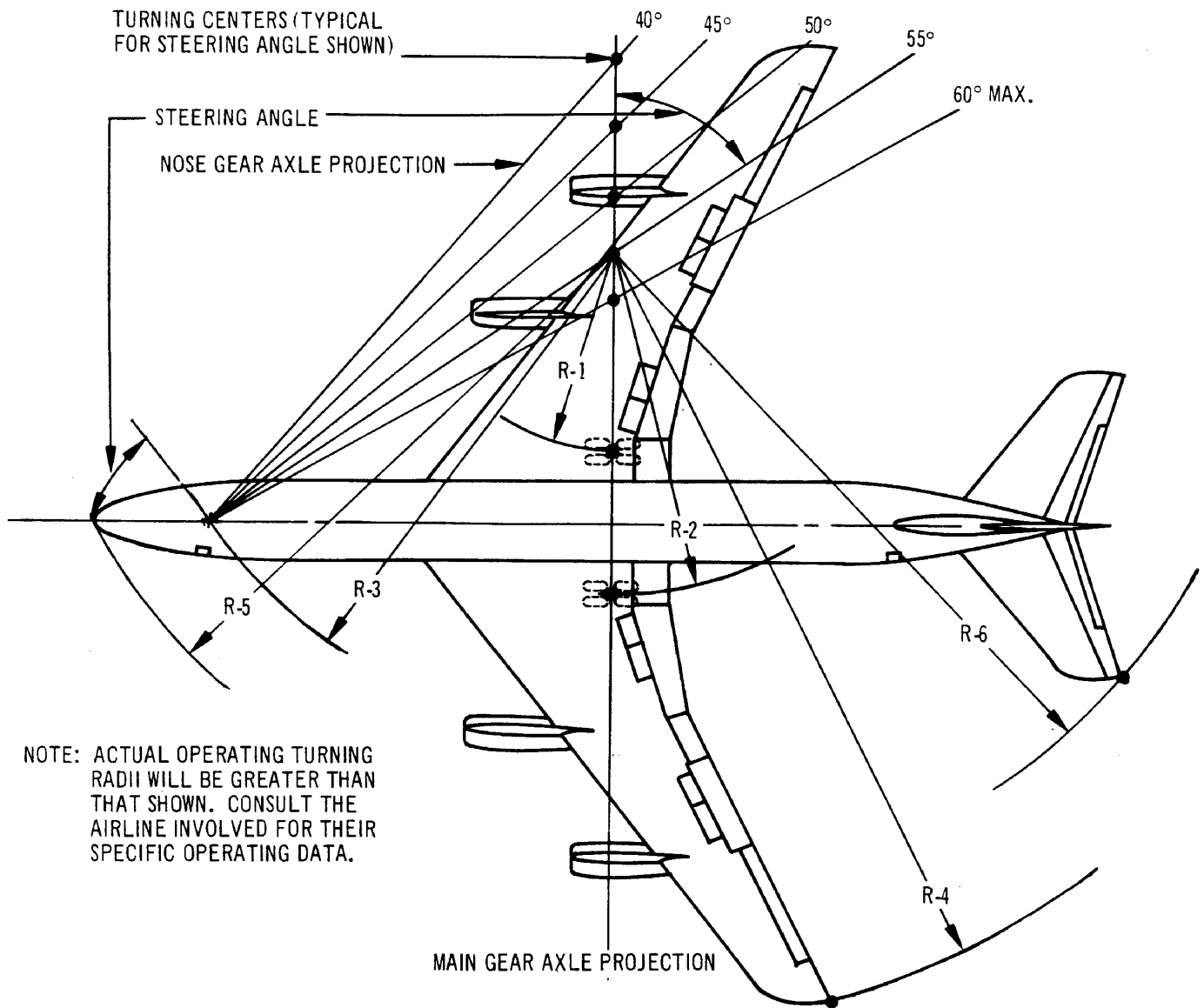

DIMENSIONS ROUNDED TO NEAREST FOOT AND 0.1 METER

STEERING ANGLE (DEGREES)	R-1		R-2		R-3		R-4		R-5		R-6	
	INNER GEAR		OUTER GEAR		NOSE GEAR		WING* TIP		NOSE		TAIL	
	FT	M	FT	M	FT	M	FT	M	FT	M	FT	M
30	91	27.7	113	34.4	118	36	177	53.9	127	38.7	147	44.8
35	74	22.6	96	29.3	103	31.4	159	48.5	114	34.7	132	40.2
40	60	18.3	82	25.0	92	28	145	44.2	104	31.7	121	36.9
45	48	14.6	70	21.3	84	25.6	134	40.8	97	29.6	112	34.1
50	39	11.9	61	18.6	77	23.5	125	38.1	91	27.7	106	32.3
55	30	9.1	52	15.8	71	21.6	117	35.7	87	26.5	100	30.5
60 MAX	23	7	45	13.7	68	20.7	110	33.5	84	25.6	96	29.3

TURNING RADII - NO SLIP ANGLE
 MODELS 707-320, -320B, -320C, -420

* ADD 2 FEET, OR 0.6 METERS, FOR -320B AND -320C

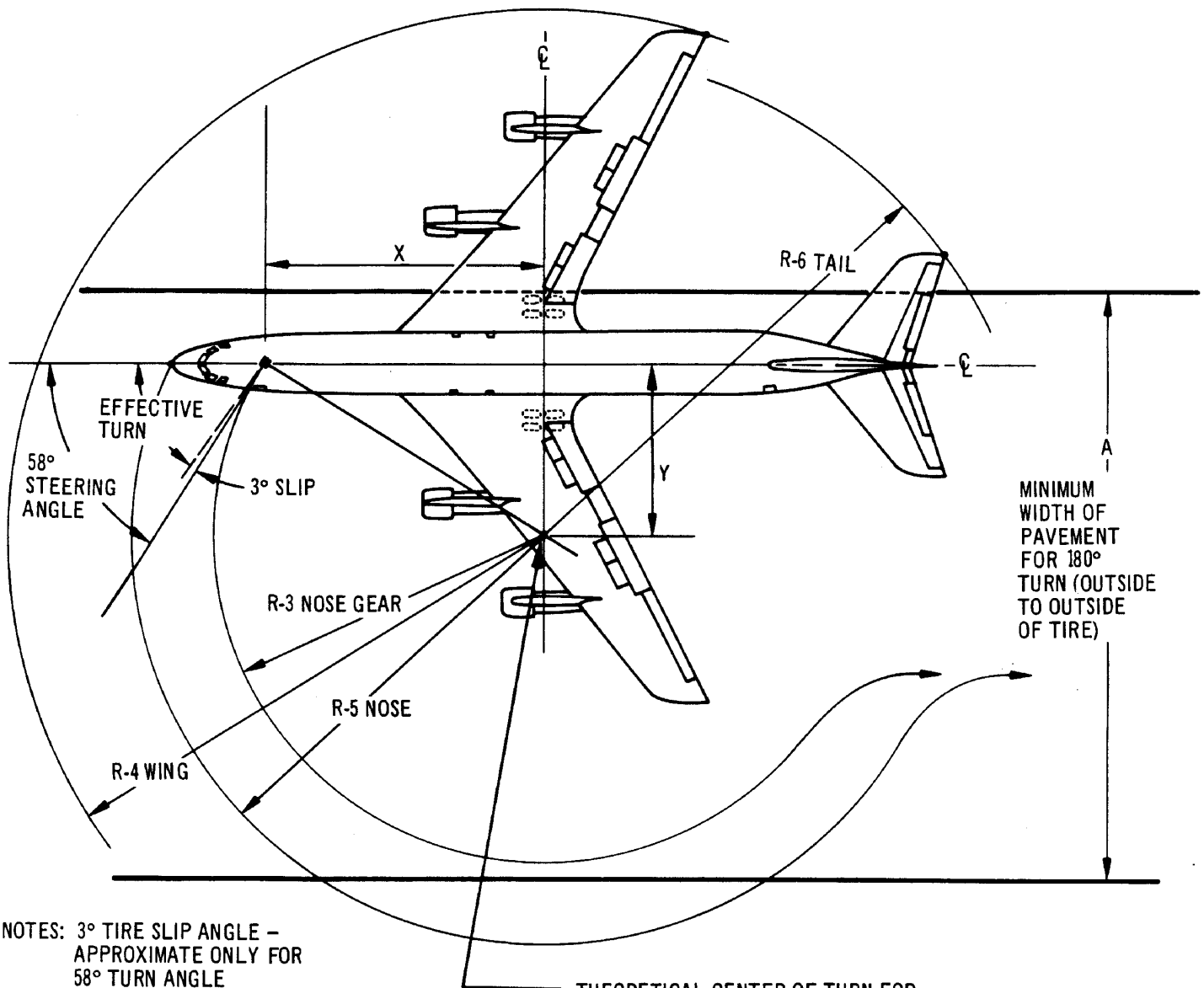

NOTES: 3° TIRE SLIP ANGLE - APPROXIMATE ONLY FOR 58° TURN ANGLE

CONSULT AIRLINE FOR ACTUAL OPERATING DATA

THEORETICAL CENTER OF TURN FOR MINIMUM TURNING RADIUS. SLOW CONTINUOUS TURNING WITH APPROXIMATELY IDLE THRUST ON ALL ENGINES. NO DIFFERENTIAL BRAKING

EFFECTIVE TURN ANGLE	X	Y	A	R-3	R-4	R-5	R-6
55°							
FT	52.33	36.6	116.2	65	107	79	95
M	15.95	11.15	35.42	19.8	32.6	24.1	29

**MINIMUM TURNING RADII - 3° SLIP ANGLE
MODEL 707-120B**

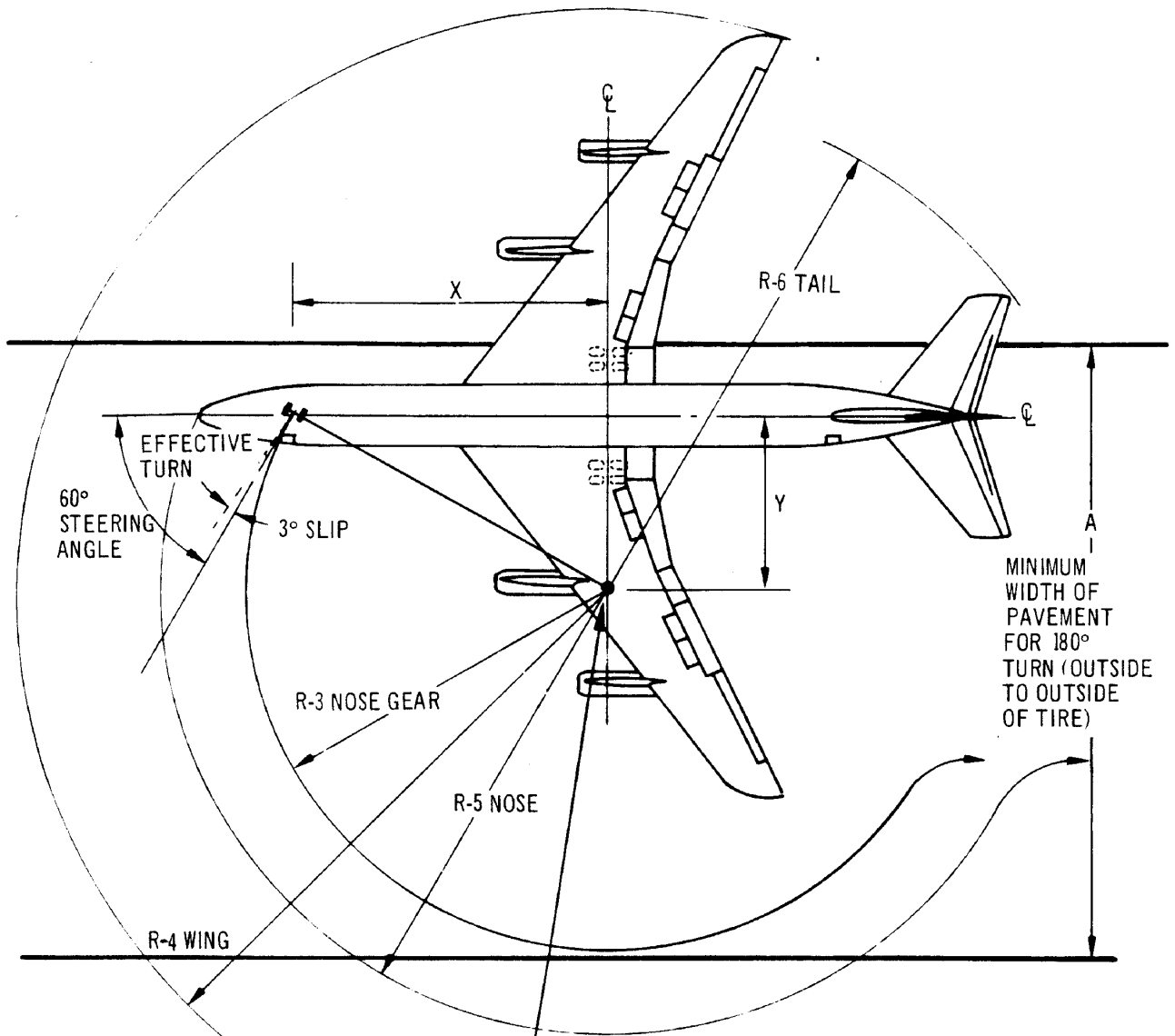

NOTES: 3° TIRE SLIP ANGLE - APPROXIMATE ONLY FOR 60° TURN ANGLE

CONSULT AIRLINE FOR ACTUAL OPERATING DATA

THEORETICAL CENTER OF TURN FOR MINIMUM TURNING RADIUS. SLOW CONTINUOUS TURNING WITH APPROXIMATELY IDLE THRUST ON ALL ENGINES. NO DIFFERENTIAL BRAKING

EFFECTIVE TURN ANGLE:	X	Y	A	R-3	R-4*	R-5	R-6
57°							
FT	59	38.3	123.4	70.5	114	85.5	98
M	17.98	11.68	37.6	21.49	34.7	26.06	29.87

* ADD 2 FEET, OR 0.6 METERS, FOR -320B AND -320C

MINIMUM TURNING RADII - 3° SLIP ANGLE
 MODELS 707-320, -320B, -320C, -420

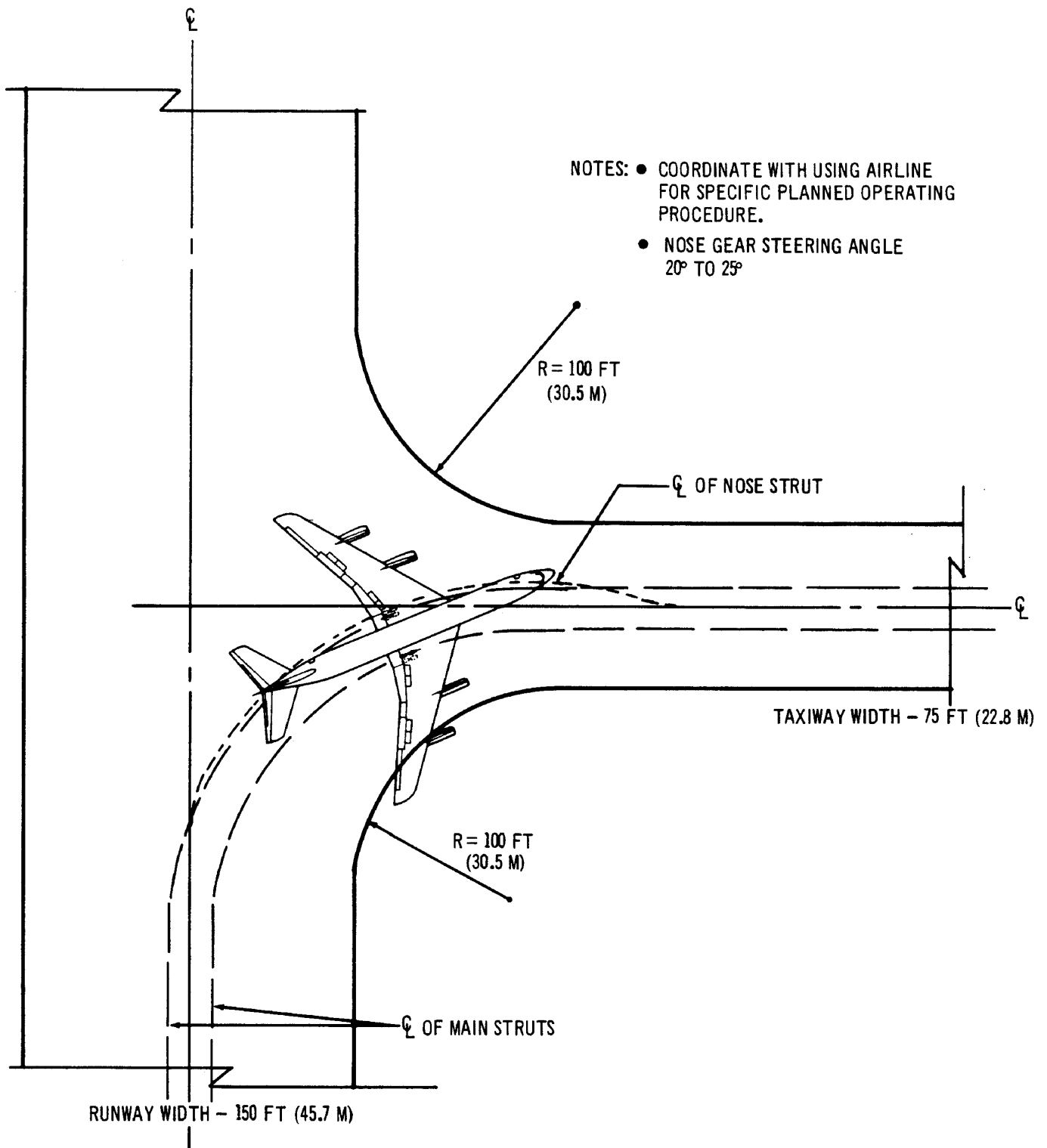

4.2 RUNWAY AND TAXIWAY TURN PATHS -
 90° TURN RUNWAY TO TAXIWAY
 MODELS 707-120B, -320B, -320C, -420

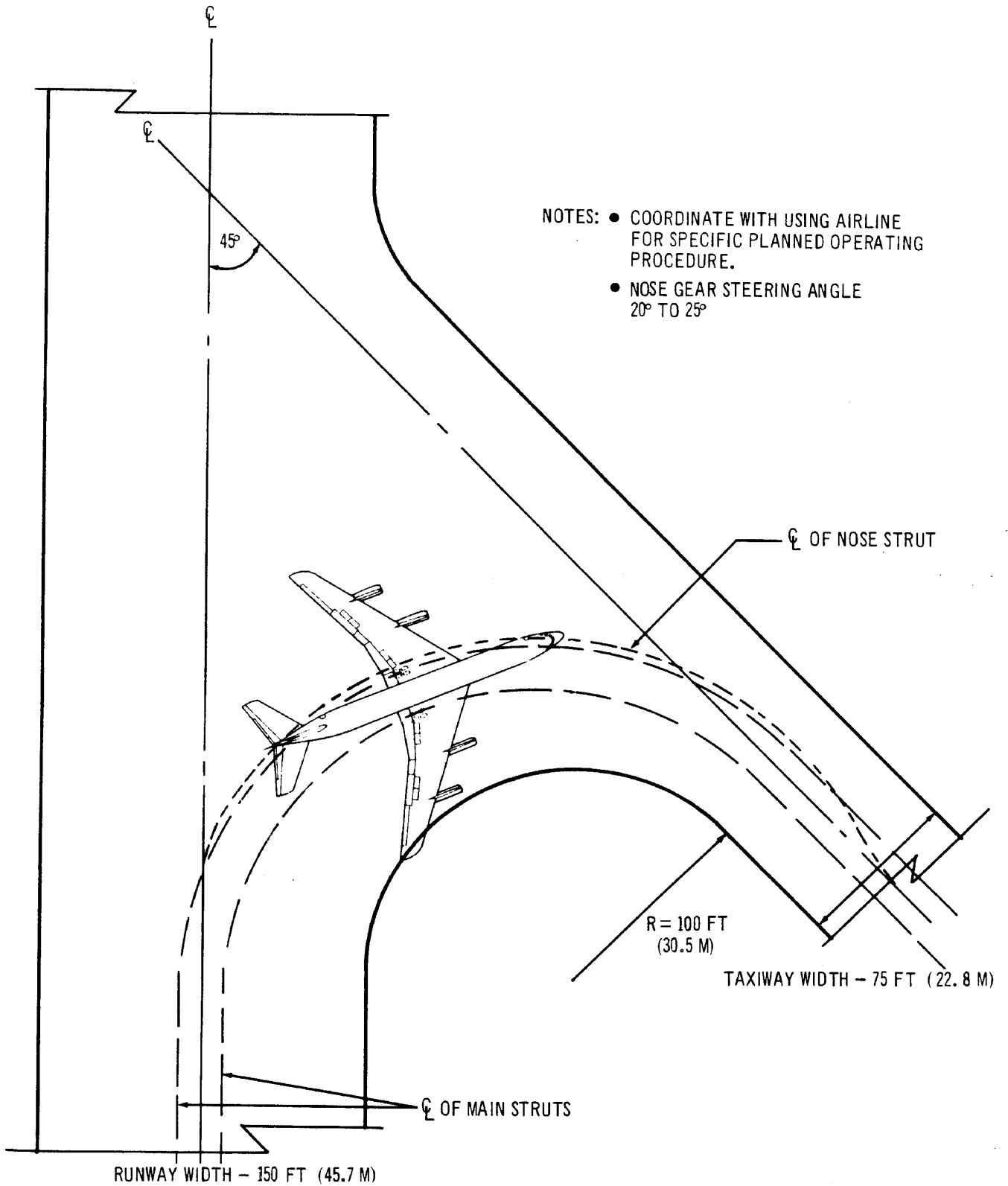

- NOTES:
- COORDINATE WITH USING AIRLINE FOR SPECIFIC PLANNED OPERATING PROCEDURE.
 - NOSE GEAR STEERING ANGLE 20° TO 25°

RUNWAY AND TAXIWAY TURN PATHS -
 RUNWAY TO TAXIWAY TURN - MORE THAN 90°
 MODELS 707-120B, -320, -320B, -320C, -420

D6-58322

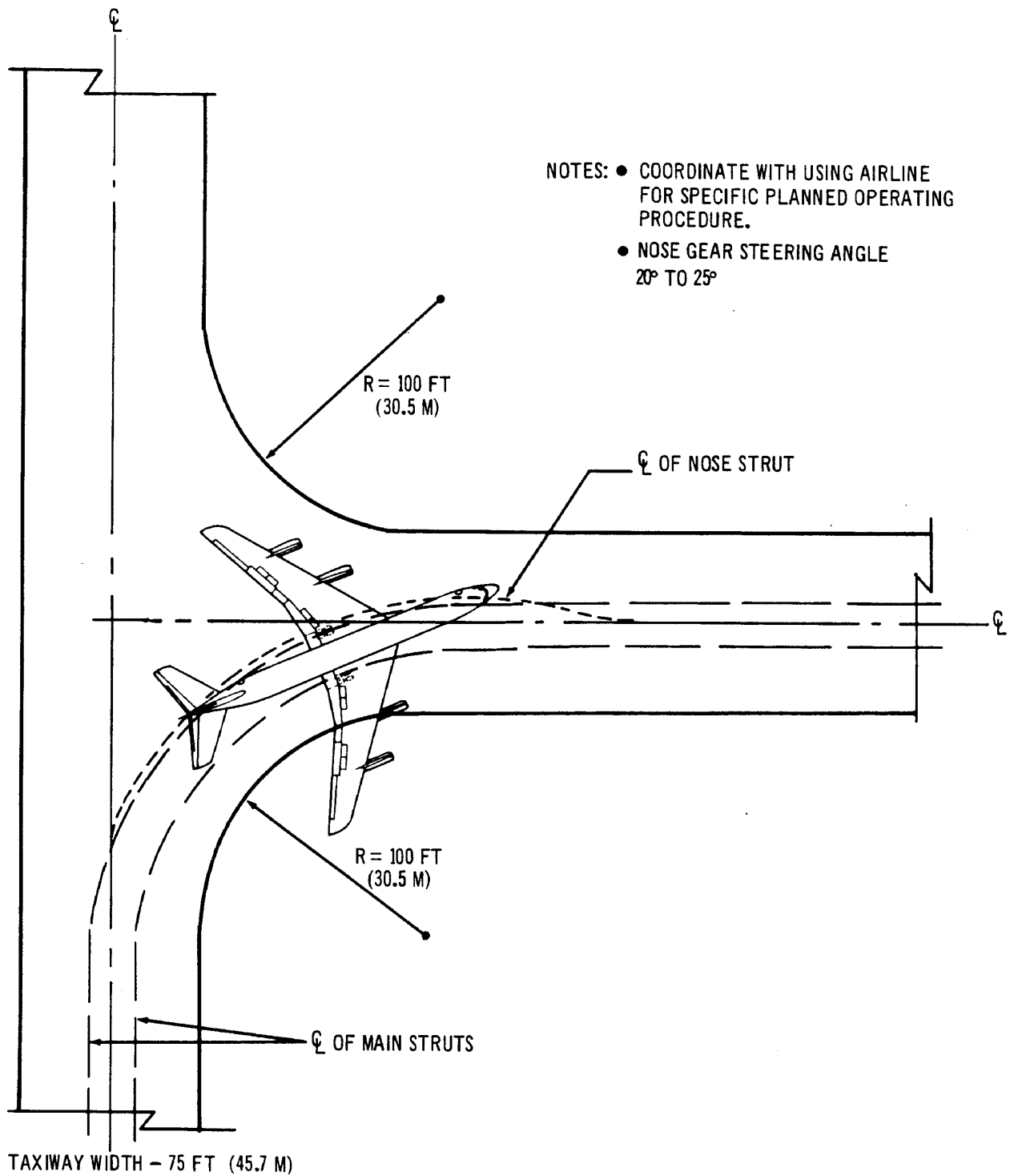

RUNWAY AND TAXIWAY TURN PATHS
TAXIWAY TO TAXIWAY TURN - 90°
MODELS 707-120B, -320, -320B, -320C, -420

MODEL	WIDTH - W	
	FT	M
707-		
120B	240	73.15
320/420	254	77.42
320B & C	256	78.03

- NOTE:
- COORDINATE WITH USING AIRLINE FOR SPECIFIC PLANNED OPERATING PROCEDURE.
 - MINIMUM CLEARANCE FOR MOVING AIRCRAFT = 40 FT (12.1 M)

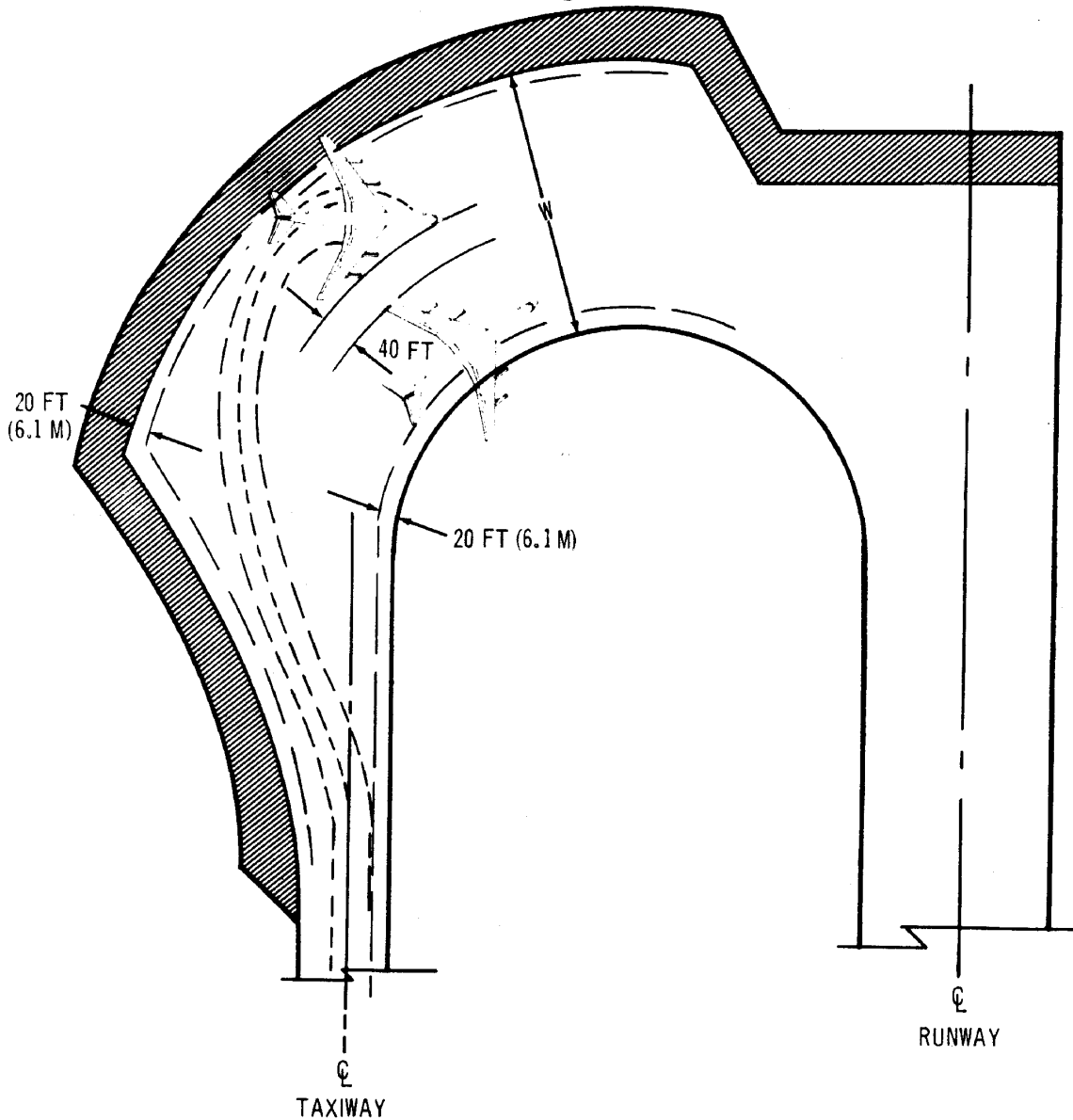

4.3 RUNWAY HOLDING APRON
 MODELS 707-120B, -320, -320B, -320C, -420

D6-58322

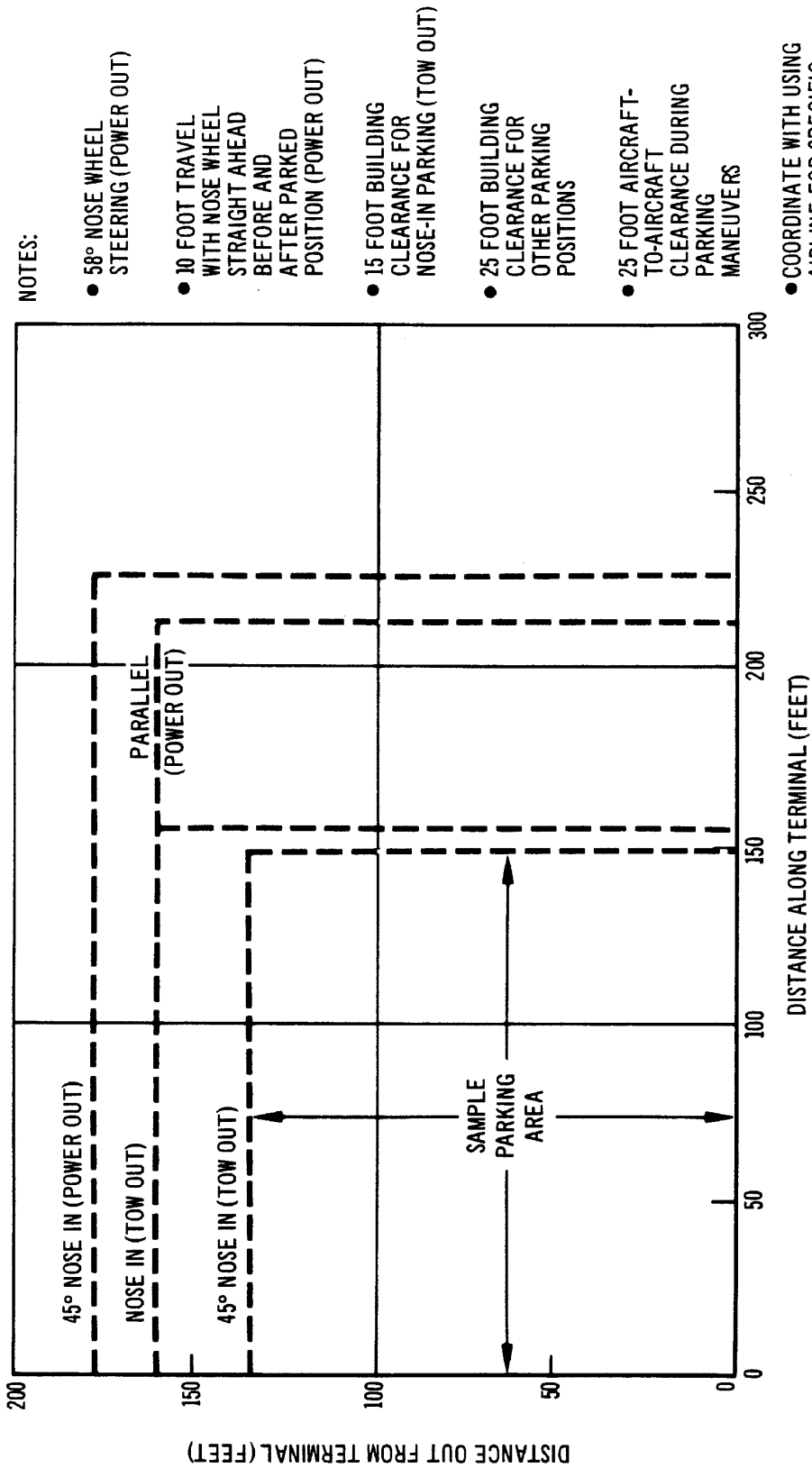

**4.4 MINIMUM PARKING SPACE REQUIREMENTS
MODEL 707-120B**

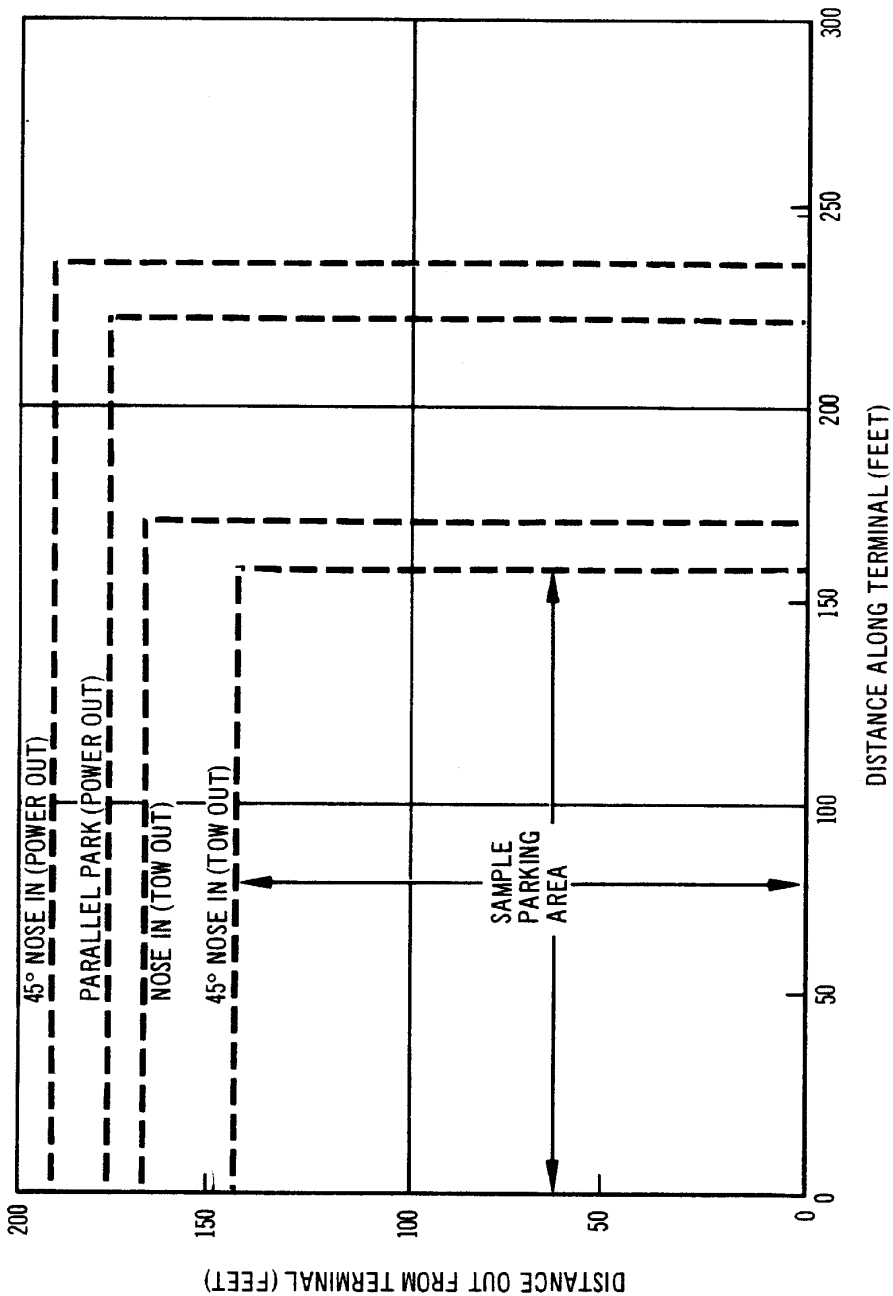

NOTES:

- 60° NOSE WHEEL STEERING (POWER OUT)
- 10 FOOT TRAVEL WITH NOSE WHEEL STRAIGHT AHEAD BEFORE AND AFTER PARKED POSITION (POWER OUT)
- 15 FOOT BUILDING CLEARANCE FOR NOSE-IN PARKING (TOW OUT)
- 25 FOOT BUILDING CLEARANCE FOR OTHER PARKING POSITIONS
- 25 FOOT AIRCRAFT-TO-AIRCRAFT CLEARANCE DURING PARKING MANEUVERS
- COORDINATE WITH USING AIRLINE FOR SPECIFIC PLANNED OPERATING PROCEDURE.

MINIMUM PARKING SPACE REQUIREMENTS
 MODELS 707-320, -320B, -320C, -420

D6-58322

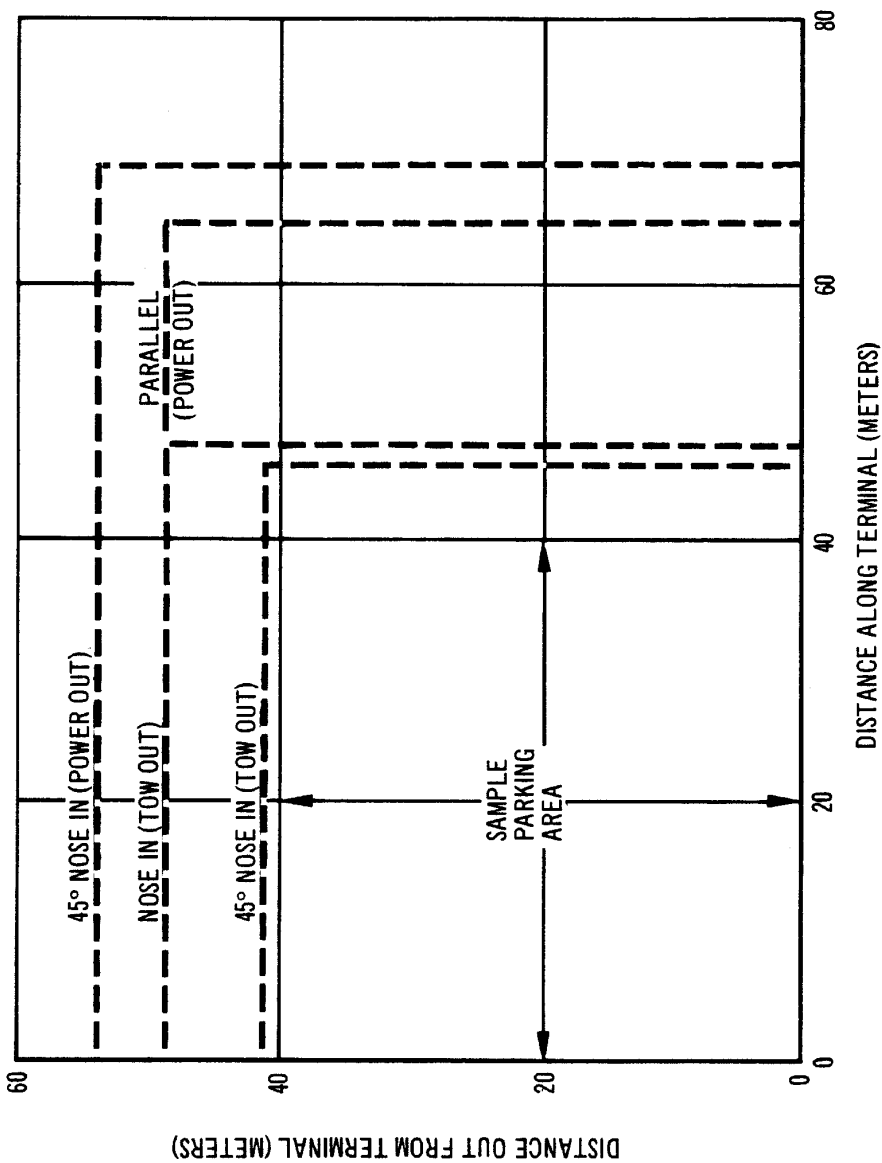

NOTES:

- 58° NOSE WHEEL STEERING (POWER OUT)
- 3 METER TRAVEL WITH NOSE WHEEL STRAIGHT AHEAD BEFORE AND AFTER PARKED POSITION (POWER OUT)
- 4.5 METER BUILDING CLEARANCE FOR NOSE-IN PARKING (TOW OUT)
- 7.6 METER BUILDING CLEARANCE FOR OTHER PARKING POSITIONS
- 7.6 METER AIRCRAFT-TO-AIRCRAFT CLEARANCE DURING PARKING MANEUVERS
- COORDINATE WITH USING AIRLINE FOR SPECIFIC PLANNED OPERATING PROCEDURE.

**MINIMUM PARKING SPACE REQUIREMENTS - METRIC
MODEL 707-120B**

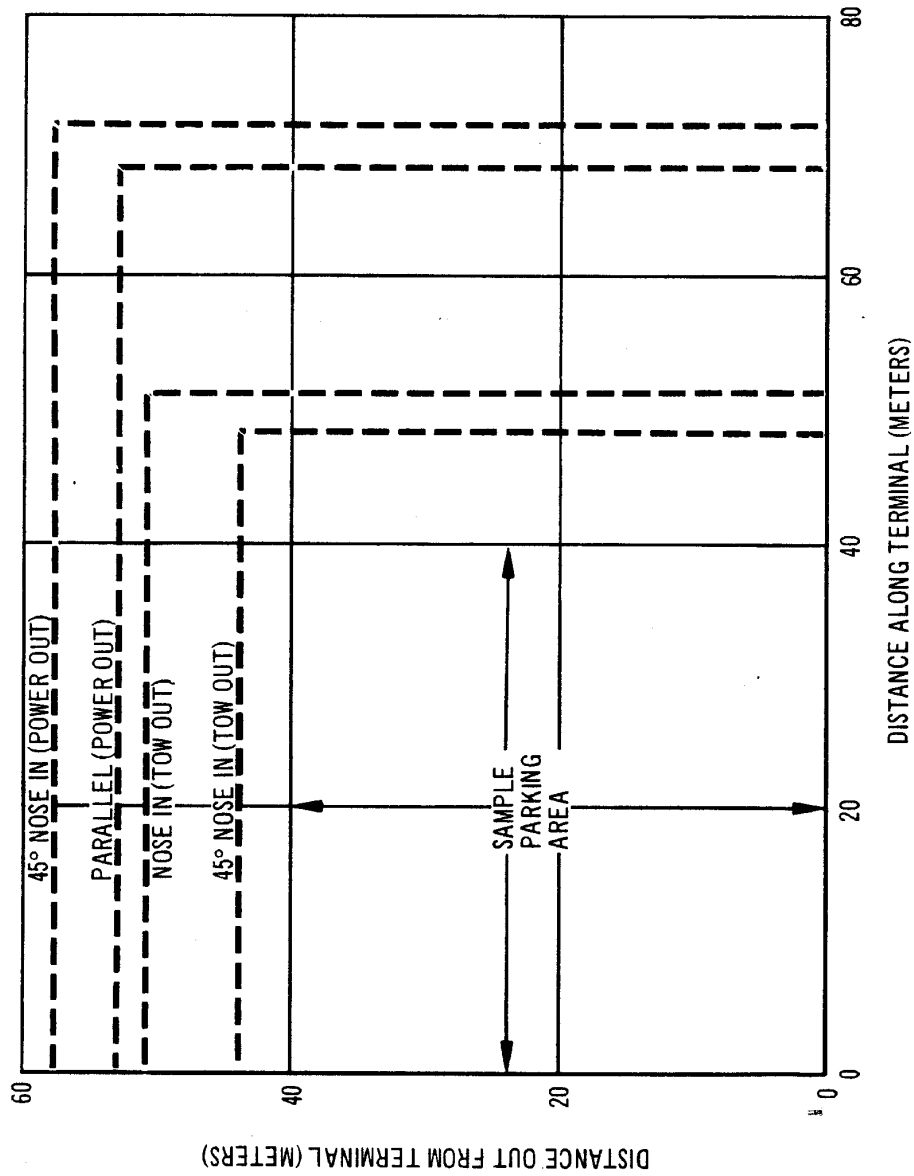

NOTES:

- 60° NOSE WHEEL STEERING (POWER OUT)
- 3 METER TRAVEL WITH NOSE WHEEL STRAIGHT AHEAD BEFORE AND AFTER PARKED POSITION (POWER OUT)
- 4.5 METER BUILDING CLEARANCE FOR NOSE-IN PARKING (TOW OUT)
- 7.6 METER BUILDING CLEARANCE FOR OTHER PARKING POSITIONS
- 7.6 METER AIRCRAFT-TO-AIRCRAFT CLEARANCE DURING PARKING MANEUVERS
- COORDINATE WITH USING AIRLINE FOR SPECIFIC PLANNED OPERATING PROCEDURE.

MINIMUM PARKING SPACE REQUIREMENTS - METRIC
 MODELS 707-320, -320B, -320C, -420

(Page Intentionally Left Blank)

5.0 TERMINAL SERVICING

- 5.1 Airplane Servicing Arrangement (Typical)**
- 5.2 Terminal Operations — Turnaround Station**
- 5.3 Terminal Operations — En Route Station**
- 5.4 Ground Service Connections**
- 5.5 Engine Starting Pneumatic Requirements**
- 5.6 Air Conditioning Requirements**
- 5.7 Ground Towing Requirements**

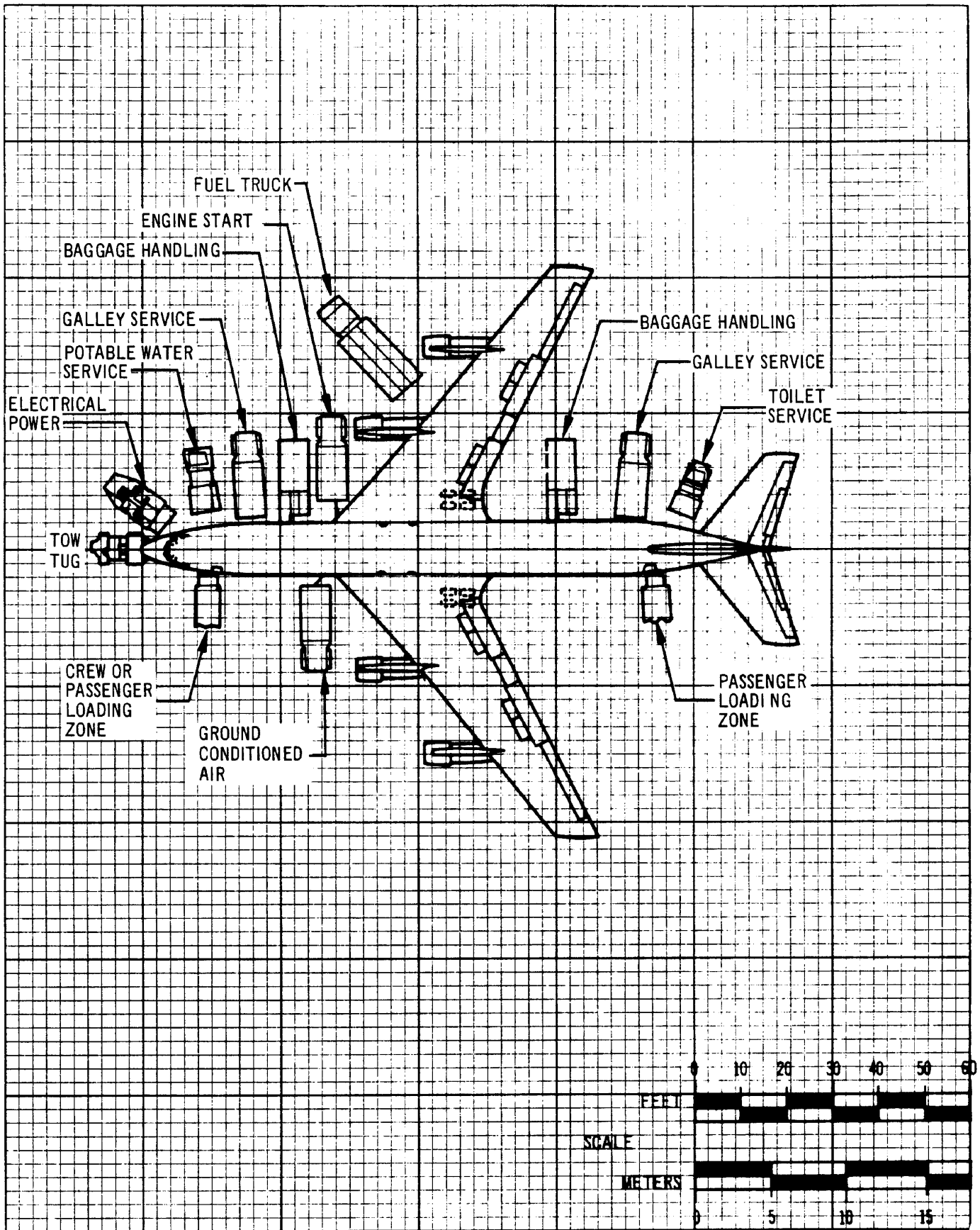

5.1 AIRPLANE SERVICING ARRANGEMENT (TYPICAL)
MODEL 707-120B

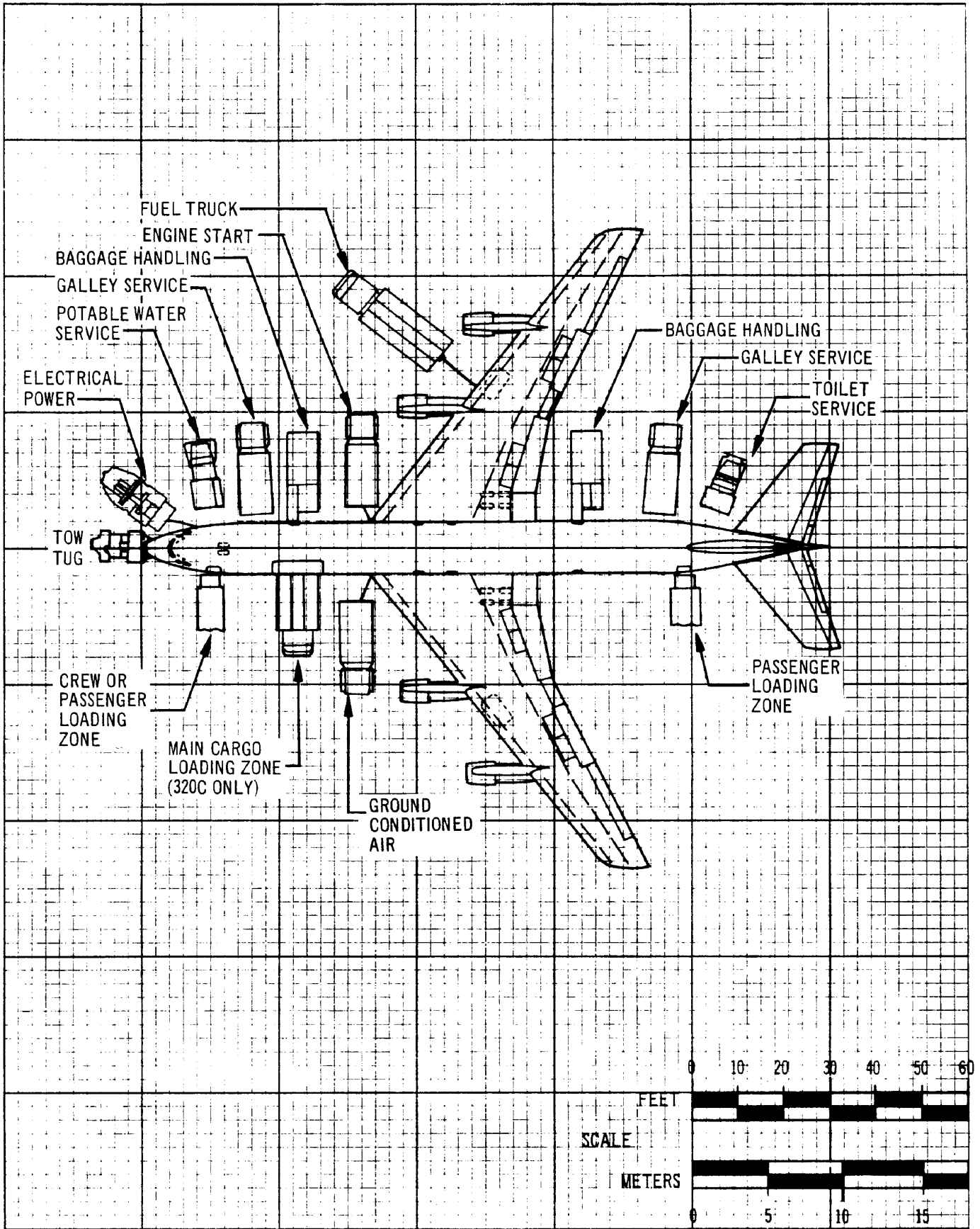

AIRPLANE SERVICING ARRANGEMENT (TYPICAL)
MODELS 707-320, -320B, -320C, -420

D6-58322

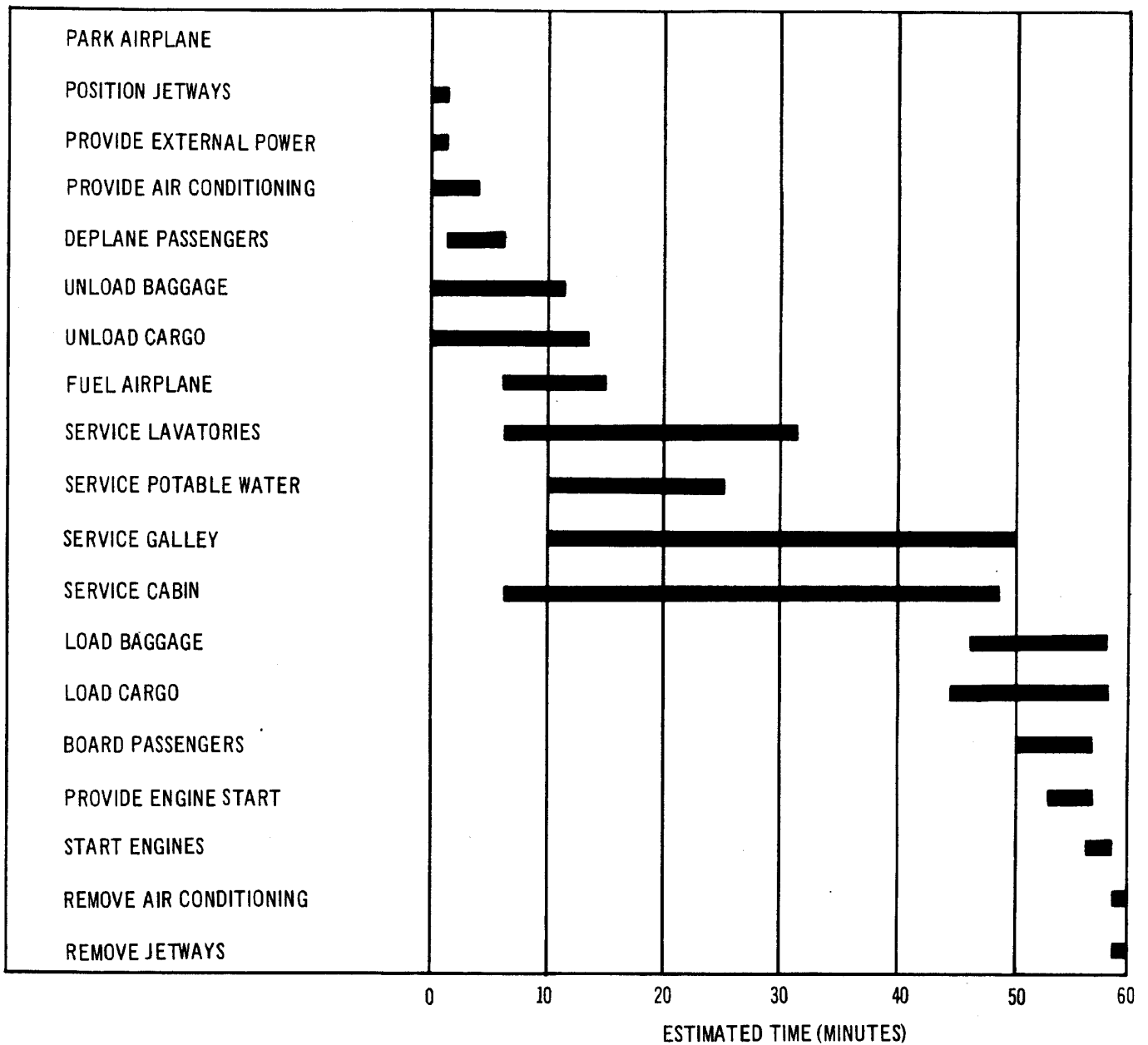

GROUND RULES

- MIXED CLASS (32F/105T)
- MAX. CARGO LOAD
- FUEL (ROUTE LEG PLUS RESERVES)
- REFUEL AT 1,200 GPM (4,542 LPM)
- FLIGHT ROUTE JFK-ORD-SFO

**5.2 TERMINAL OPERATIONS - TURNAROUND STATION
MODEL 707-120B**

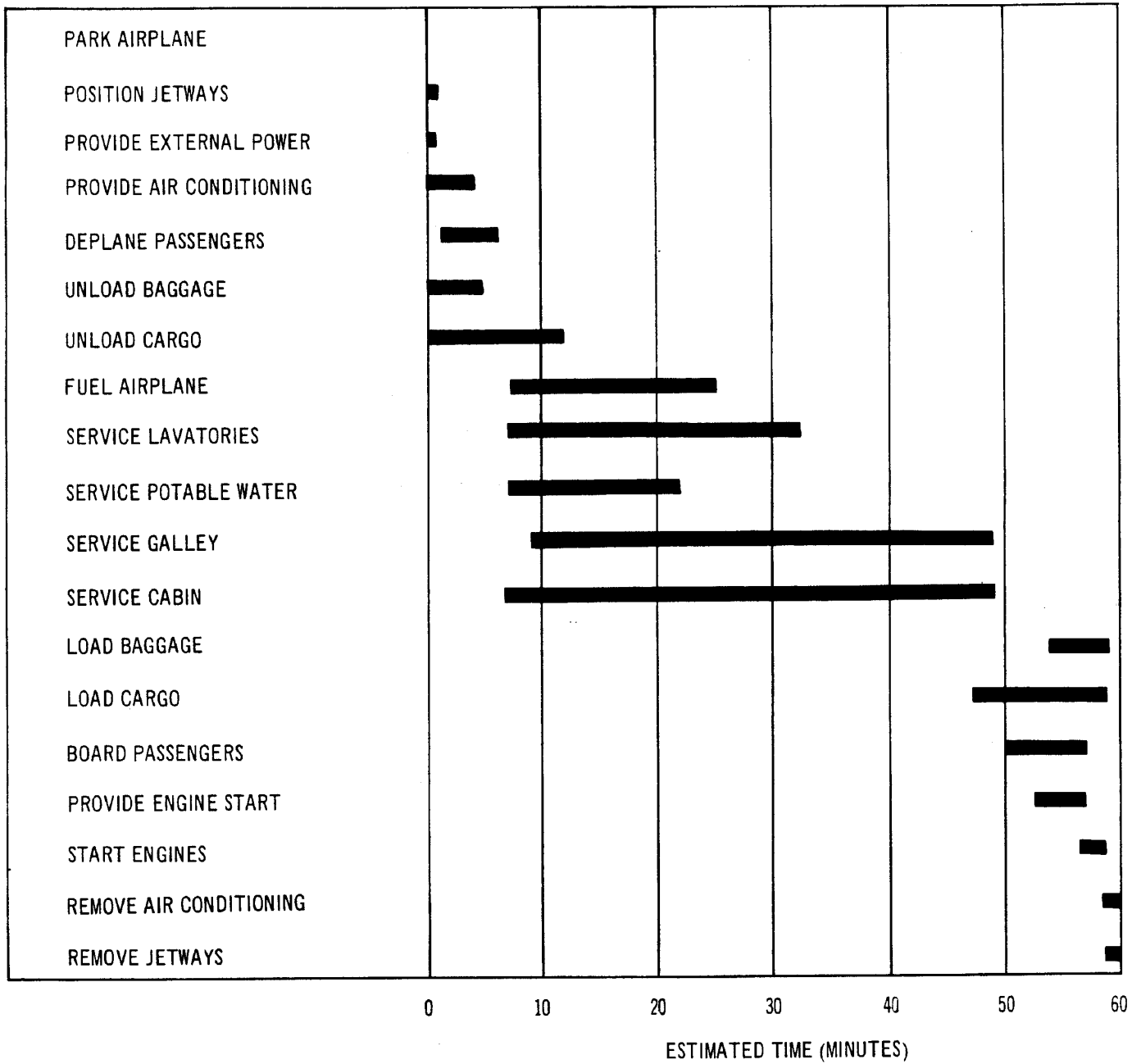

GROUND RULES

- MIXED CLASS (18F/123T)
- MAX. CARGO LOAD
- FUEL (ROUTE LEG PLUS RESERVES)
- REFUEL AT 1,200 GPM (4,542 LPM)
- FLIGHT ROUTE SFO-HNL-TYO

TERMINAL OPERATIONS - TURNAROUND STATION (INTERNATIONAL)
MODELS 707-320, -320B, -320C, -420

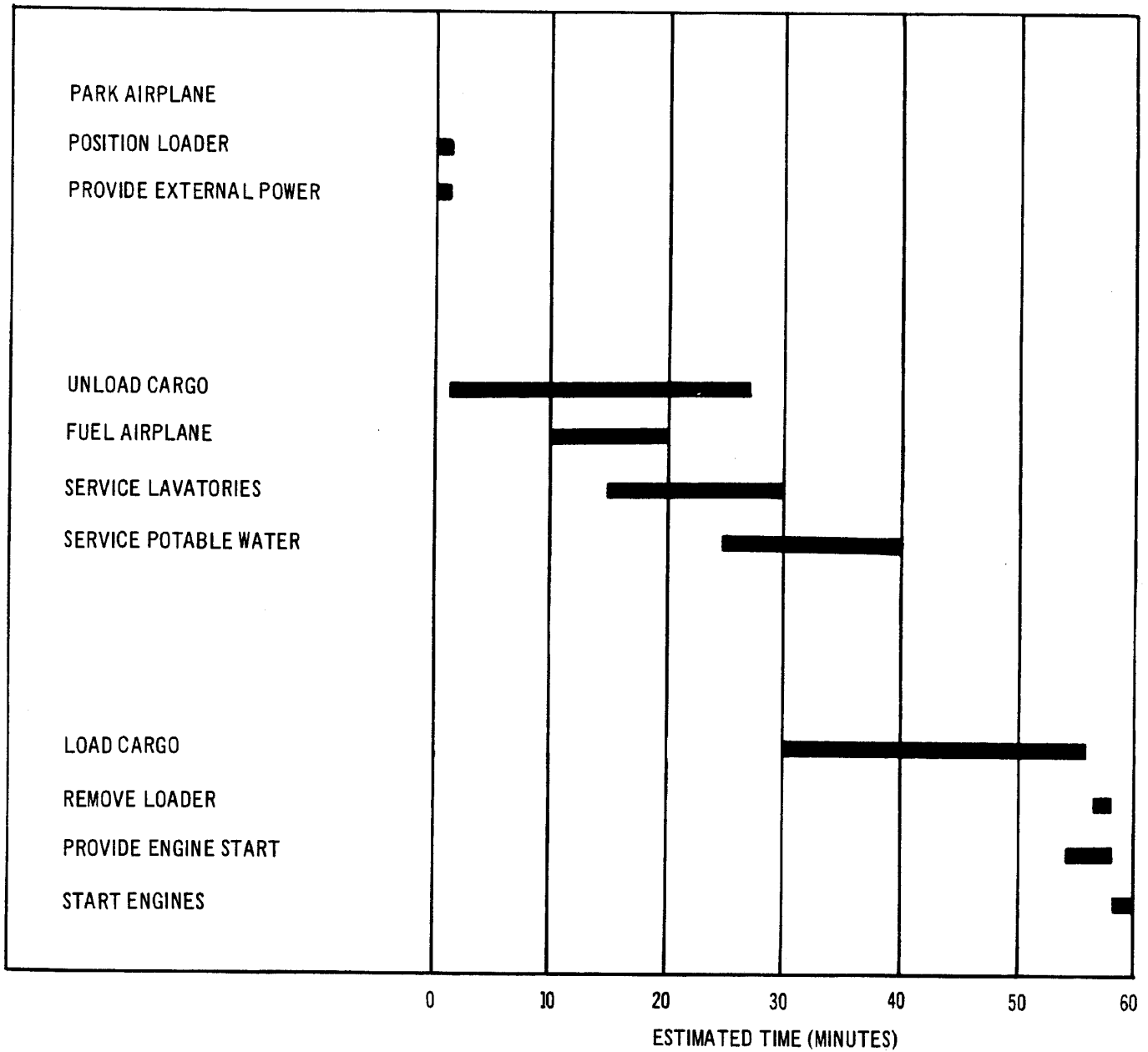

GROUND RULES

- ALL CARGO CONFIGURATION
- 13 PALLETS ON UPPER DECK – 59,300 LB (26,922 KG)
- BULK CARGO ON LOWER DECK – 17,000 LB (7,718 KG)
- TOTAL PAYLOAD – 76,300 LB (36,640 KG)
- FUEL (ROUTE LEG PLUS RESERVES)
- REFUEL 1,200 GPM (4,542 LPM)
- FLIGHT ROUTE JFK-ORD-SFO

**TERMINAL OPERATIONS - TURNAROUND STATION
MODEL 707-320C - ALL CARGO**

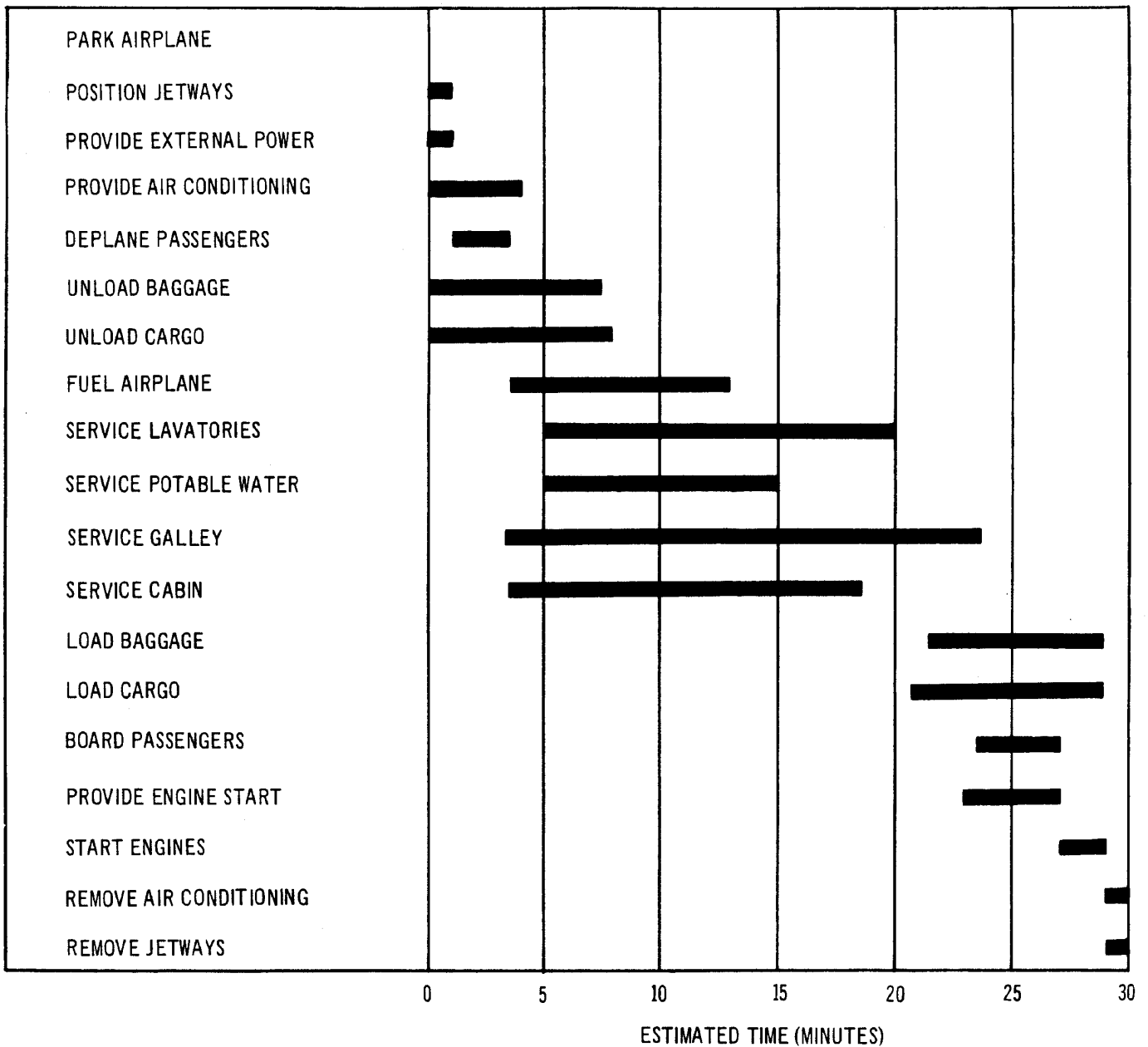

GROUND RULES

- MIXED CLASS (32F/ 105T)
- DEPLANE 1/2 PASSENGERS AND 1/2 CARGO
- DEPART WITH FULL PASSENGER AND CARGO LOAD
- FUEL (ROUTE LEG PLUS RESERVES)
- REFUEL AT 1,200 GPM (4,542 LPM)
- FLIGHT ROUTE JFK-ORD-SFO

**5.3 TERMINAL OPERATIONS - EN ROUTE STATION
MODEL 707-120B**

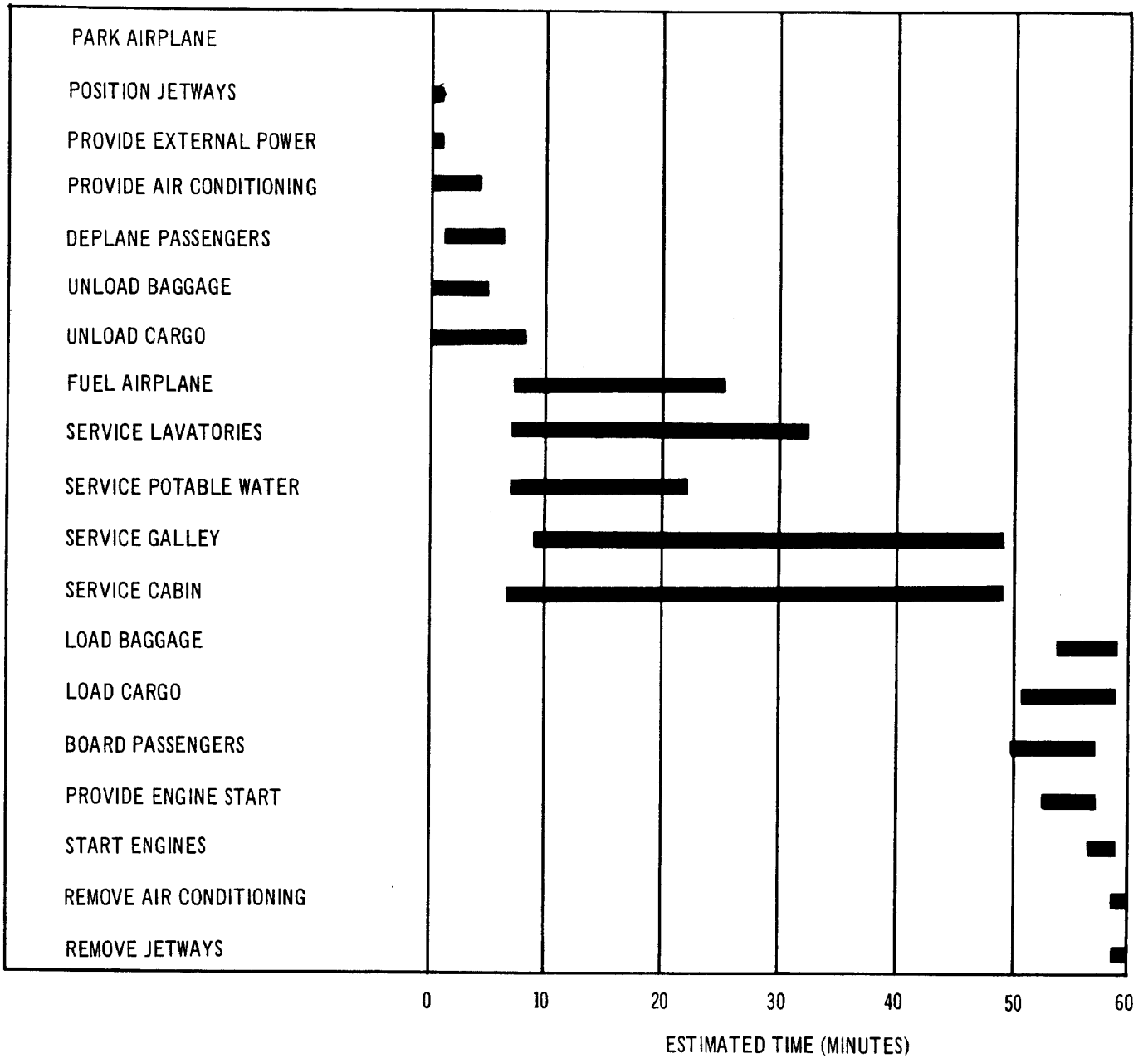

GROUND RULES

- MIXED CLASS (18F/123T)
- DEPLANE ALL PASSENGERS AND 2/3 CARGO
- DEPART WITH FULL PASSENGER AND CARGO LOAD
- FUEL (ROUTE LEG PLUS RESERVES)
- REFUEL AT 1,200 GPM (4,542 LPM)
- FLIGHT ROUTE SFO-HNL-TYO

**TERMINAL OPERATIONS - EN ROUTE STATION (INTERNATIONAL)
 MODELS 707-320, -320B, -320C, -420**

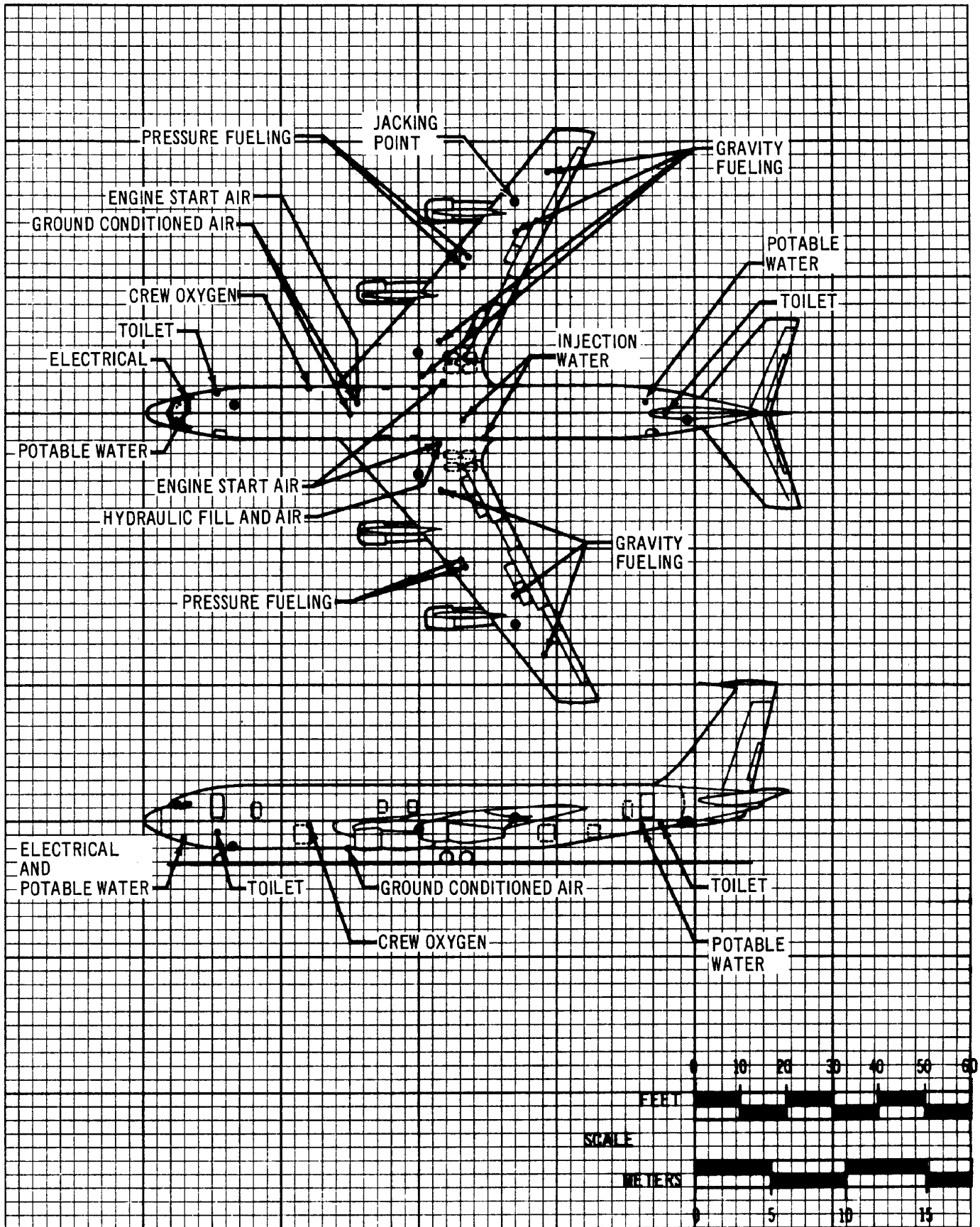

5.4 GROUND SERVICE CONNECTIONS
MODEL 707-120B

D6-58322

SYSTEM	DISTANCE AFT OF NOSE		DISTANCE FROM AIRPLANE CENTERLINE				HEIGHT FROM GROUND	
	FEET	METERS	LEFT SIDE FEET	LEFT SIDE METERS	RIGHT SIDE FEET	RIGHT SIDE METERS	FEET	METERS
<p>ELECTRICAL SYSTEM</p> <p>ONE SERVICE CONNECTION</p> <p>GROUND POWER REQUIRED – 75 KW MAXIMUM AT 115/200 VOLTS, 400 CYCLES, 3 PHASE*.</p> <p>* EXCEPT 707-123B, -131 AND -131B HAVE 2 SERVICE CONNECTIONS. MAXIMUM GROUND POWER REQUIREMENT FOR THESE MODELS IS 160 KW.</p>	9	2.7			2	0.6	6	1.8

**GROUND SERVICE CONNECTIONS
MODEL 707-120B**

SYSTEM	DISTANCE AFT OF NOSE		DISTANCE FROM AIRPLANE CENTERLINE				HEIGHT FROM GROUND	
	FEET	METERS	LEFT SIDE FEET	LEFT SIDE METERS	RIGHT SIDE FEET	RIGHT SIDE METERS	FEET	METERS
FUEL SYSTEM FOUR UNDERWING PRESSURE CONNECTIONS (2 EACH WING) 50 PSI (3.52 KG/CM ²) MAXIMUM. MAXIMUM FUELING RATE USING 4 CONNECTIONS IS APPROXIMATELY 1500 U.S. GPM (5,678 LPM). TOTAL USABLE TANK CAPACITY VARIES BETWEEN 13,486 U.S. GAL. (51,000 L) AND 17,406 U.S. GAL. (66,000 L) SUBJECT TO CUSTOMER OPTION. SEVEN OVERWING GRAVITY CONNECTIONS (3 ON LEFT WING, 4 ON RIGHT WING).	70	21.3	34	10.4			9	2.7
	71	21.6	35	10.7	34	10.4	9	2.7
	70	21.3			35	10.7	9	2.7
	71	21.6					9	2.7
	60	18.3			9	2.7		TOP OF WING
	64	19.5			17	5.2		TOP OF WING
	82	24.9			36	11.0		TOP OF WING
	89	27.1			55	16.8		TOP OF WING
	64	19.5	17	5.2				TOP OF WING
	82	24.9	36	11.0				TOP OF WING
89	27.1	55	16.8				TOP OF WING	

**GROUND SERVICE CONNECTIONS
MODEL 707-120B**

D6-58322

SYSTEM	DISTANCE AFT OF NOSE		DISTANCE FROM AIRPLANE CENTERLINE				HEIGHT FROM GROUND	
	FEET	METERS	LEFT SIDE FEET	LEFT SIDE METERS	RIGHT SIDE FEET	RIGHT SIDE METERS	FEET	METERS
GROUND CONDITIONED AIR TWO SERVICE CONNECTIONS (EITHER THE 8 IN. OR 3 IN. BELOW SUBJECT TO CUSTOMER OPTION): 8 IN. (20.3 CM) CONDITIONED AIR CONNECTION. 40 IN. H ₂ O, 160°F MAXIMUM, 300 LB/MINUTE. (102.0 CM H ₂ O, 71°C MAXIMUM, 136 KG/MINUTE) AT FITTING. 3 IN. (7.6 CM) SERVICE AIR CONNECTION 40 PSIG, 450°F MAXIMUM, 350 LB MINUTE. (2.8 KG/CM ² , 232°C MAXIMUM, 159 KG/MINUTE) AT FITTING.	44	13.4	0	0	0	0	4	1.2
HYDRAULIC SYSTEM ONE SERVICE CONNECTION (LH WHEEL WELL) 1-3/4 IN. (4.5 CM) FILLER NECK ON UTILITY RESERVOIR.	46	14.0	7	2.1	3	0.9	5	1.5
	64	19.5					5	1.5

GROUND SERVICE CONNECTIONS
MODEL 707-120B

SYSTEM	DISTANCE FROM AIRPLANE CENTERLINE		DISTANCE FROM AIRPLANE CENTERLINE		HEIGHT FROM GROUND	
	LEFT SIDE	RIGHT SIDE	LEFT SIDE	RIGHT SIDE	FEET	METERS
	FEET	METERS	FEET	METERS	FEET	METERS
OXYGEN SYSTEM*						
CREW SYSTEM						
ONE SERVICE CONNECTION: (FORWARD RH CARGO HOLD)	38	11.6	5	1.5	9	2.7
* PASSENGER SYSTEM OXYGEN BOTTLES MUST BE REMOVED FROM THE AIRPLANE TO BE RECHARGED.						

**GROUND SERVICE CONNECTIONS
MODEL 707-120B**

D6-58322

SYSTEM	DISTANCE AFT OF NOSE		DISTANCE FROM AIRPLANE CENTERLINE				HEIGHT FROM GROUND	
	FEET	METERS	LEFT SIDE FEET	LEFT SIDE METERS	RIGHT SIDE FEET	RIGHT SIDE METERS	FEET	METERS
PNEUMATIC AIR ENGINE STARTING (EITHER A. & C. OR B. & C. BELOW, SUBJECT TO CUSTOMER OPTION) A. ONE SERVICE CONNECTION: (RH WHEEL WELL) 3,000 PSIG (211 KG/CM ²) B. TWO SERVICE CONNECTIONS: (LH WHEEL WELL) (RH WHEEL WELL) 700-800 PSIG (49-56 KG/CM ²) C. ONE SERVICE CONNECTION: 3 IN. (7.6 CM) FITTING 46 PSIG (3.2 KG/CM ²) UTILITY HYDRAULIC RESERVOIR ONE SERVICE CONNECTION: 45 PSIG (3.2 KG/CM ²) (LH WHEEL WELL)	64	19.5	7	2.1	7	2.1	5	1.5
	64	19.5	7	2.1	7	2.1	5	1.5
	64	19.5					5	1.5
	46	14.0			3	0.9		
	64	19.5	7	2.1			5	1.5

**GROUND SERVICE CONNECTIONS
MODEL 707-120B**

SYSTEM	DISTANCE FROM AIRPLANE CENTERLINE		DISTANCE FROM AIRPLANE CENTERLINE		DISTANCE FROM AIRPLANE CENTERLINE		DISTANCE FROM AIRPLANE CENTERLINE		HEIGHT FROM GROUND	
	LEFT SIDE	RIGHT SIDE	LEFT SIDE	RIGHT SIDE	LEFT SIDE	RIGHT SIDE	LEFT SIDE	RIGHT SIDE	FEET	METERS
	FEET	METERS	FEET	METERS	FEET	METERS	FEET	METERS	FEET	METERS
TOILET SYSTEM										
TWO SERVICE CONNECTIONS:										
4 IN. (10.2 CM) OUTLET FOR EACH GROUP OF 2 OR 3 TOILETS.										
TO SERVICE 5 OR 6 TOILETS:										
DRAIN 125-150 U.S. GAL. (474-568 L) OF WASTE.										
FLUSH WITH 36 U.S. GAL. (137 L) OF WATER AND 24 U.S. GAL. (91 L) OF CHEMICAL.										
RECHARGE EACH TOILET WITH 4 U.S. GAL. (15.2 L) OF CHEMICAL AFTER FLUSHING.										
	17	5.2	0	0	5	1.5	0	0	9	2.7
	115	35.1							8	2.4

**GROUND SERVICE CONNECTIONS
MODEL 707-120B**

D6-58322

SYSTEM	DISTANCE AFT OF NOSE		DISTANCE FROM AIRPLANE CENTERLINE				HEIGHT FROM GROUND	
	FEET	METERS	LEFT SIDE FEET	LEFT SIDE METERS	RIGHT SIDE FEET	RIGHT SIDE METERS	FEET	METERS
WATER SYSTEM (POTABLE) TWO SERVICE CONNECTIONS: FWD TANK - 43 U.S. GAL. (163 L) AFT TANK - 43 U.S. GAL. (163 L) 1/2 OR 3/4 IN. (1.3 OR 1.91 CM) HOSE FITTING. FILL PRESSURE - 20 TO 85 PSIG (1.4 TO 5.97 KG/CM ²).	9	2.7			20 IN.	0.5	7	2.1
	111	33.8			26 IN.	0.7	8	2.4
WATER INJECTION SYSTEM ONE SERVICE CONNECTION (ON MODELS SHOWN BELOW) A. 707-121, -139: TANK CAPACITY, 705 U.S. GAL. (2,660 L) GRAVITY FILL AT 50 U.S. GAL. (189 L) PER MINUTE MAXIMUM. B. 707-123B, -124, -131B: TANK CAPACITY, 705 U.S. GAL. (2,660 L). PRESSURE FILL AT 100 U.S. GAL. (378 L) PER MINUTE MAXIMUM AT 50 PSI (3.52 KG/CM ²). (LH WHEEL WELL)	75	22.9	6	1.8			10	3.0
	70	21.3	2	0.6			7	2.1

**GROUND SERVICE CONNECTIONS
MODEL 707-120B**

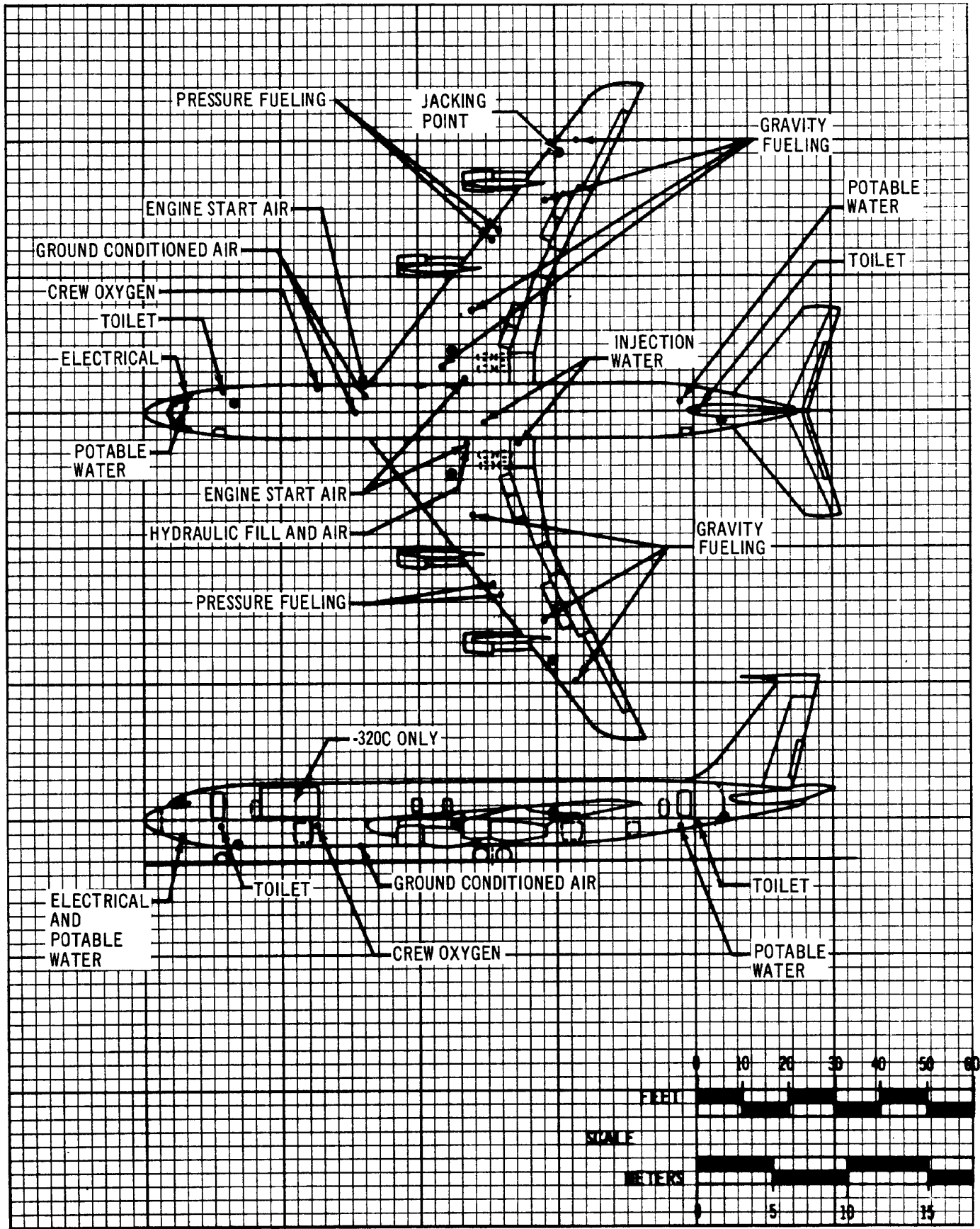

GROUND SERVICE CONNECTIONS
MODELS 707-320, -320B, -320C, -420

D6-58322

SYSTEM	DISTANCE AFT OF NOSE		DISTANCE FROM AIRPLANE CENTERLINE				HEIGHT FROM GROUND	
	FEET	METERS	LEFT SIDE FEET	LEFT SIDE METERS	RIGHT SIDE FEET	RIGHT SIDE METERS	FEET	METERS
<p>ELECTRICAL SYSTEM</p> <p>ONE SERVICE CONNECTION:</p> <p>GROUND POWER REQUIRED - 75 KW MAXIMUM AT 115/200 VOLTS, 400 CYCLES, 3 PHASE*.</p> <p>* EXCEPT 707-331, -331B AND -323C HAVE 2 SERVICE CONNECTIONS. MAXIMUM GROUND POWER REQUIREMENT FOR THESE MODELS IS 160 KW.</p>	9	2.7			2	0.6	6	1.8

GROUND SERVICE CONNECTIONS
MODELS 707-320, -320B -320C, -420

SYSTEM	DISTANCE AFT OF NOSE		DISTANCE FROM AIRPLANE CENTERLINE				HEIGHT FROM GROUND	
	FEET	METERS	LEFT SIDE FEET	LEFT SIDE METERS	RIGHT SIDE FEET	RIGHT SIDE METERS	FEET	METERS
FUEL SYSTEM FOUR UNDERWING PRESSURE CONNECTIONS (2 EACH WING): 50 PSI (3.52 KG/CM ²) MAXIMUM. MAXIMUM FUELING RATE USING 4 CONNECTIONS IS APPROXIMATELY 1,500 U.S. GPM (5,678 LPM). TOTAL USABLE TANK CAPACITY VARIES BETWEEN 21,262 U.S. GAL. (80,600 L) AND 23,815 U.S. GAL. (88,400 L), SUBJECT TO CUSTOMER OPTION. SEVEN OVERWING GRAVITY CONNECTIONS (3 ON LEFT WING; 4 ON RIGHT WING)	77	23.5	39	11.9			10	3.0
	78	23.8	41	12.5			10	3.0
	77	23.5			39	11.9	10	3.0
	78	23.8			41	12.5	10	3.0
	67	20.4						TOP OF WING
	72	21.9			10	3.0		TOP OF WING
	89	27.1			23	7.0		TOP OF WING
	96	29.3			48	14.6		TOP OF WING
	72	21.9	23	7.0	61	18.6		TOP OF WING
	89	27.1	48	14.6				TOP OF WING
96	29.3	61	18.6				TOP OF WING	

GROUND SERVICE CONNECTIONS
MODELS 707-320, -320B, -320C -420

SYSTEM	DISTANCE AFT OF NOSE		DISTANCE FROM AIRPLANE CENTERLINE				HEIGHT FROM GROUND	
	FEET	METERS	LEFT SIDE FEET	LEFT SIDE METERS	RIGHT SIDE FEET	RIGHT SIDE METERS	FEET	METERS
GROUND CONDITIONED AIR TWO SERVICE CONNECTIONS (EITHER THE 8 IN. OR 3 IN. BELOW, SUBJECT TO CUSTOMER OPTION) 8 IN. (20.3 CM) CONDITIONED AIR CONNECTION. 40 IN. H ₂ O, 160°F MAXIMUM, 300 LB/MIN (102.0 CM H ₂ O, 71°C MAXIMUM, 136 KG/MIN) AT FITTING. 3 IN. (7.6 CM) SERVICE AIR CONNECTION. 40 PSIG, 450°F MAXIMUM, 350 LB/MIN (2.8 KG/CM ² , 232°C MAXIMUM, 159 KG/MIN AT FITTING).	47	14.3	0	0	0	0	4	1.2
	49	14.9			3	0.9	5	1.5
HYDRAULIC SYSTEM ONE SERVICE CONNECTION: LH WHEEL WELL 1-3/4 IN. (4.5 CM) FILLER NECK ON UTILITY RESERVOIR.	71	21.6	7	2.1			5	1.5

**GROUND SERVICE CONNECTIONS
MODELS 707-320, -320B, -320C, -420**

SYSTEM	DISTANCE AFT OF NOSE		DISTANCE FROM AIRPLANE CENTERLINE				HEIGHT FROM GROUND	
	DISTANCE		LEFT SIDE		RIGHT SIDE		FEET	METERS
	FEET	METERS	FEET	METERS	FEET	METERS		
OXYGEN SYSTEM CREW SYSTEM ONE SERVICE CONNECTION: (FORWARD RH CARGO HOLD) * PASSENGER SYSTEM OXYGEN BOTTLES MUST BE REMOVED FROM THE AIRPLANE TO BE RECHARGED (EXCEPT 707-436, -465 AND VC-137C)	38	11.6			5	1.5	9	2.7
PNEUMATIC AIR ENGINE STARTING TWO SERVICE CONNECTIONS: 3000 PSIG (211 KG/CM ²) 46 PSIG (3.2 KG/CM ²) 3 IN. (7.6 CM) FITTING. UTILITY HYDRAULIC RESERVOIR ONE SERVICE CONNECTION: 45 PSIG (3.2 KG/CM ²) (LH WHEEL WELL)	71	21.6			7	2.1	4	1.2
	49	14.9			3	0.9	5	1.5
	71	21.6					5	1.5

GROUND SERVICE CONNECTIONS
MODELS 707-320, -320B, -320C, -420

D6-58322

SYSTEM	DISTANCE FROM AIRPLANE CENTERLINE		DISTANCE FROM AIRPLANE CENTERLINE		DISTANCE FROM AIRPLANE CENTERLINE		DISTANCE FROM AIRPLANE CENTERLINE		DISTANCE FROM AIRPLANE CENTERLINE	
	LEFT SIDE	RIGHT SIDE	LEFT SIDE	RIGHT SIDE	LEFT SIDE	RIGHT SIDE	LEFT SIDE	RIGHT SIDE	FEET	METERS
	FEET	METERS	FEET	METERS	FEET	METERS	FEET	METERS	FEET	METERS
TOILET SYSTEM	17	5.2	0	0	5	1.5	9	2.7		
	122	37.1			0	0	8	2.4		

TWO SERVICE CONNECTIONS:
 4 IN. (10.2 CM) OUTLET FOR EACH GROUP OF 2 OR 3 TOILETS.
 TO SERVICE 5 OR 6 TOILETS:
 DRAIN 125-150 U.S. GAL. (474-568 L) OF WASTE.
 FLUSH WITH 36 U.S. GAL. (137 L) OF WATER AND 24 U.S. GAL. (91 L) OF CHEMICAL.
 RECHARGE EACH TOILET WITH 4 U.S. GAL. (15.2 L) OF CHEMICAL AFTER FLUSHING.

GROUND SERVICE CONNECTIONS
MODEL 707-320, -320B, -320C, -420

SYSTEM	DISTANCE FROM AIRPLANE CENTERLINE		DISTANCE FROM AIRPLANE CENTERLINE		DISTANCE FROM AIRPLANE CENTERLINE		DISTANCE FROM AIRPLANE CENTERLINE		HEIGHT FROM GROUND	
	LEFT SIDE	RIGHT SIDE	LEFT SIDE	RIGHT SIDE	LEFT SIDE	RIGHT SIDE	LEFT SIDE	RIGHT SIDE	FEET	METERS
	FEET	METERS	FEET	METERS	FEET	METERS	FEET	METERS	FEET	METERS
<p>WATER SYSTEM (POTABLE)</p> <p>TWO SERVICE CONNECTIONS:</p> <p>FWD TANK, 43 OR 60 U.S. GAL* (16.3 OR 22.7 L) AFT TANK, 43 OR 60 U.S. GAL* (16.3 OR 22.7 L)</p> <p>1/2 OR 3/4 IN. (1.3 OR 1.91 CM) HOSE FITTING. FILL PRESSURE 20 TO 85 PSIG (1.4 TO 5.97 KG/CM²).</p> <p>* SUBJECT TO CUSTOMER OPTION, EXCEPT FOR THE 707-320C, WHICH HAS THE 43 U.S. GAL. OPTION.</p>										
	9	2.7							7	2.1
	118	36.0			20 IN.	0.5			8	2.4
					26 IN.	0.7				

GROUND SERVICE CONNECTIONS
MODELS 707-320, -320B, -320C, -420

D6-58322

SYSTEM	DISTANCE AFT OF NOSE		DISTANCE FROM AIRPLANE CENTERLINE				HEIGHT FROM GROUND	
	FEET	METERS	LEFT SIDE FEET	LEFT SIDE METERS	RIGHT SIDE FEET	RIGHT SIDE METERS	FEET	METERS
WATER INJECTION SYSTEM ONE SERVICE CONNECTION (ON MODELS SHOWN BELOW) 707 - 320/B/C AND - 420 TANK CAPACITY, 540 U.S. GAL. (2,100 L.) GRAVITY FILL AT 50 U.S. GAL. (189 L) PER MIN MAXIMUM. 707-331B: TANK CAPACITY, 540 U.S. GAL. (2,100 L.) PRESSURE FILL AT 100 U.S. GAL. (378L) PER MINUTE MAXIMUM AT 50 PSI (3.52 KG/CM ²). (LH WHEEL WELL)	82	25.0	6	1.8			10	3.0
	75	23.2	2	0.6			7	2.1

GROUND SERVICE CONNECTIONS
MODELS 707-320, -320B, -320C, -420

D6-58322

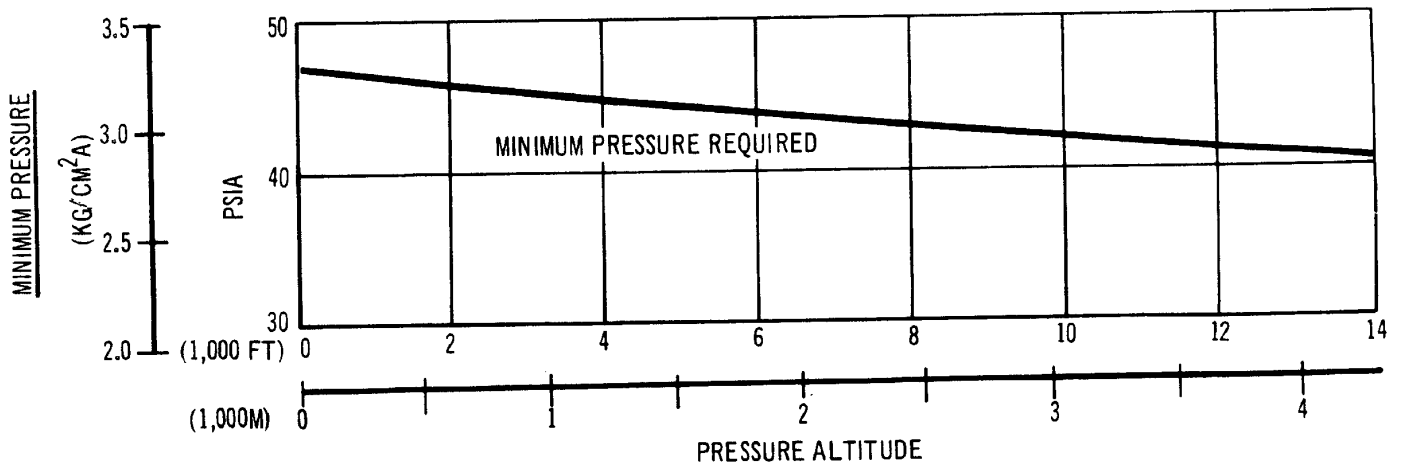

- NOTES:
- MAXIMUM PRESSURE WITH NO AIRFLOW -75 PSIA (5.2 KG/CM²A)
 - TO PROVIDE ADEQUATE ENGINE STARTING, THE PNEUMATIC SUPPLY MUST ALLOW OPERATION ON OR ABOVE THE CURVE.
 - ENGINE STARTS MAY BE OBTAINED FROM SOME POINT BELOW THE CURVE; HOWEVER, TO PRECLUDE ENGINE DAMAGE, THE AIRPLANE MAINTENANCE MANUAL MUST BE CONSULTED

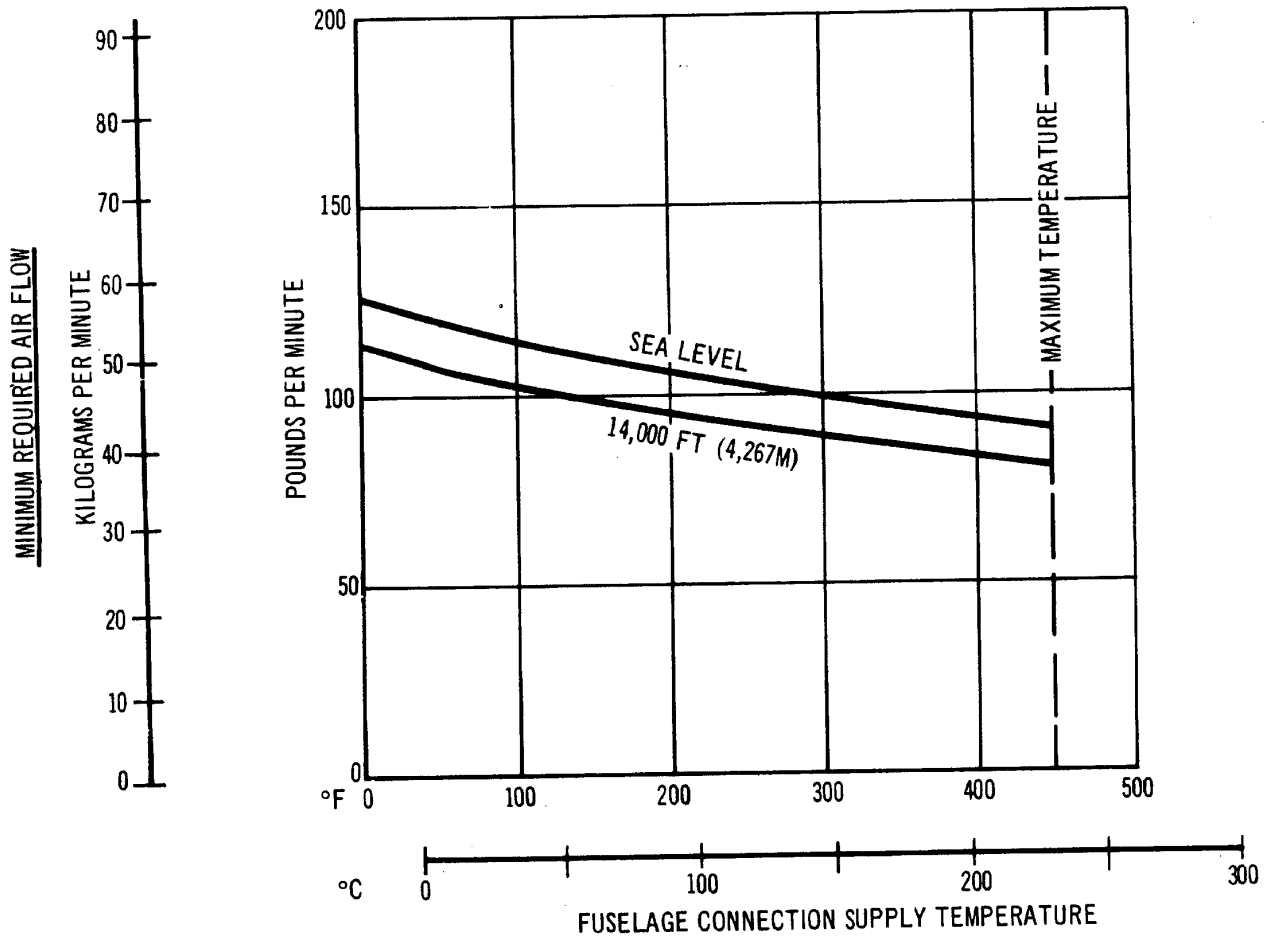

5.5 ENGINE STARTING PNEUMATIC REQUIREMENTS
MODELS 707-120B, -320, -320B, -320C, -420

D6-58322

INITIAL CABIN TEMPERATURE AT 0°F (-17.8°C). NO GALLEY LOAD. NO ELECTRICAL LOAD. NO CREW OR PASSENGERS. TEMPERATURE AT GROUND CONNECTION IS 450°F (232.2°C).

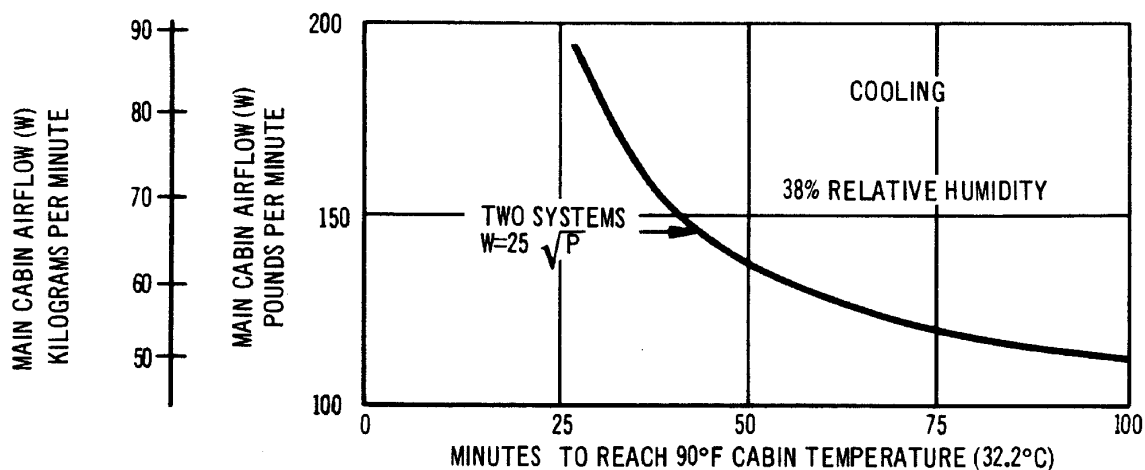
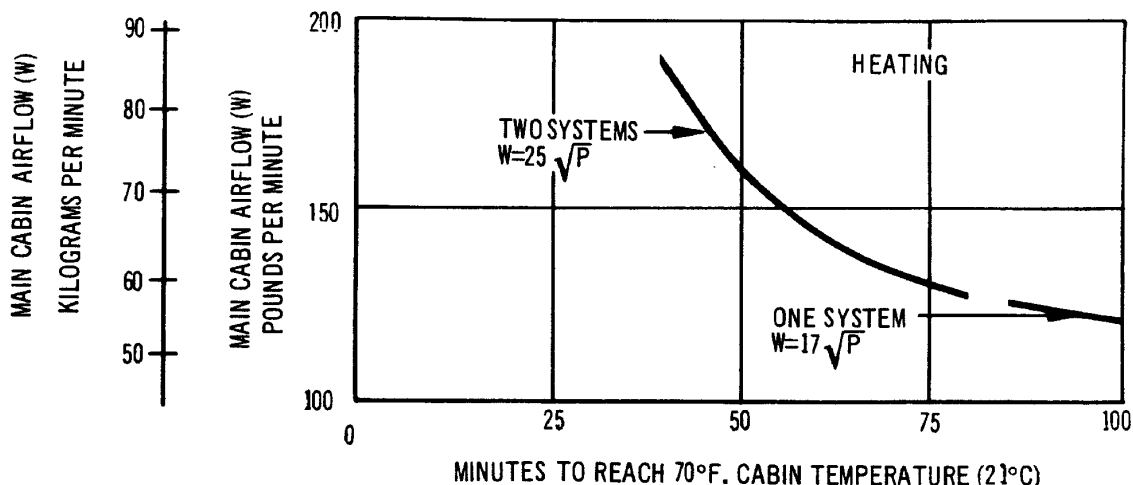

INITIAL CABIN TEMPERATURE AT 103°F (39.4°C). OUTSIDE AIR TEMPERATURE AT 103°F. Solar Load 5,100 BTU/HOUR (1,280 KG CAL/HOUR). NO GALLEY LOAD NO CREW OR PASSENGERS. NO ELECTRICAL LOAD. TEMPERATURE AT GROUND CONNECTION IS 450°F (232.2°C).

NOTES:

- P = ABSOLUTE PRESSURE AT THE GROUND CONNECTION
- ALL DOORS AND HATCHES CLOSED

5.6 AIR CONDITIONING REQUIREMENTS - PULL UP/PULL DOWN MODEL 707-120B

CONDITIONS:

- 1 CABIN AT 75°F (24° C). 120 PASSENGERS AND CREW. NO GALLEY LOAD. BRIGHT DAY SOLAR LOAD 5,100 BTU/HOUR (1,280 KG CAL./HOUR). ELECTRICAL LOAD 8,000 BTU/HOUR (2,020 KG CAL./HOUR).
- 2 CABIN AT 80°F (26.7° C). ALL OTHER CONDITIONS SAME AS IN 1.
- 3 CABIN AT 70°F (21° C). THREE CREW MEMBERS ONLY. GALLEY LOAD 8,000 BTU/HOUR. BRIGHT DAY SOLAR LOAD 5,100 BTU/HOUR. ELECTRICAL LOAD 8,000 BTU/HOUR.
- 4, 5 AND 6 CABIN AT 75°F (24° C). NO CREW OR PASSENGERS, NO OTHER HEAT LOAD

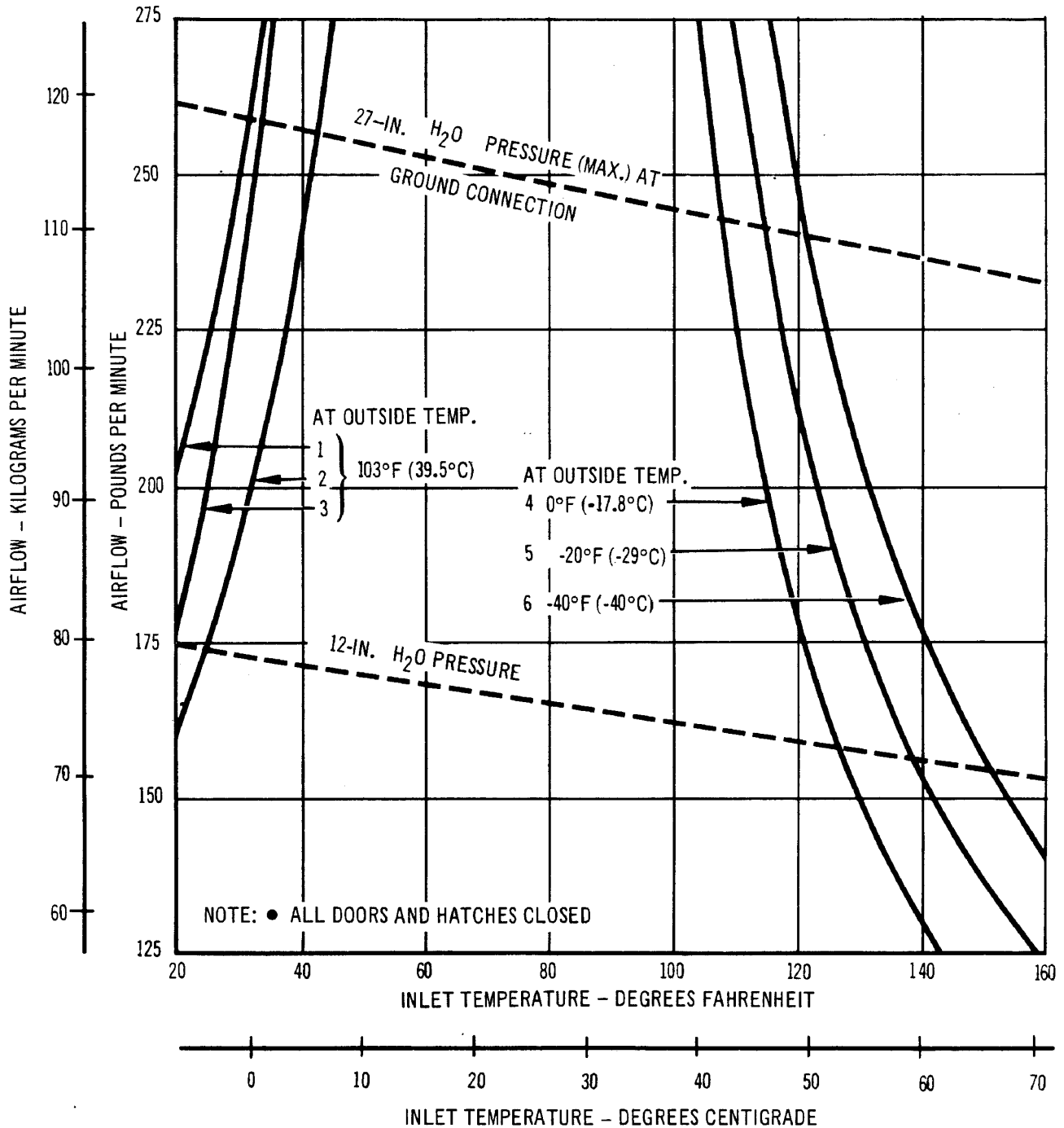

AIR CONDITIONING REQUIREMENTS - PRE-CONDITIONED AIRPLANE MODEL 707-120B

D6-58322

INITIAL CABIN TEMPERATURE AT 0°F (-17.8°C). NO GALLEY LOAD. NO ELECTRICAL LOAD. NO CREW OR PASSENGERS. TEMPERATURE AT GROUND CONNECTION IS 450°F (232.2°C).

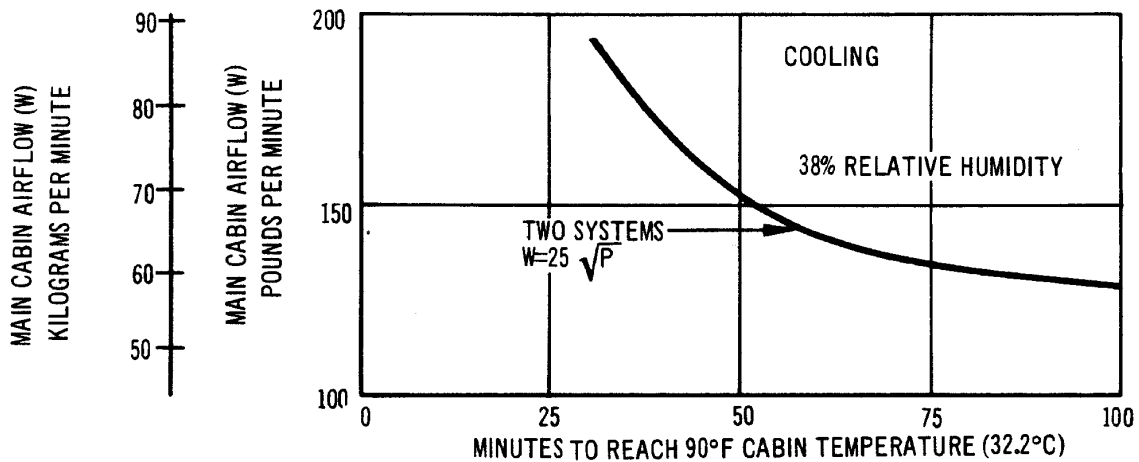
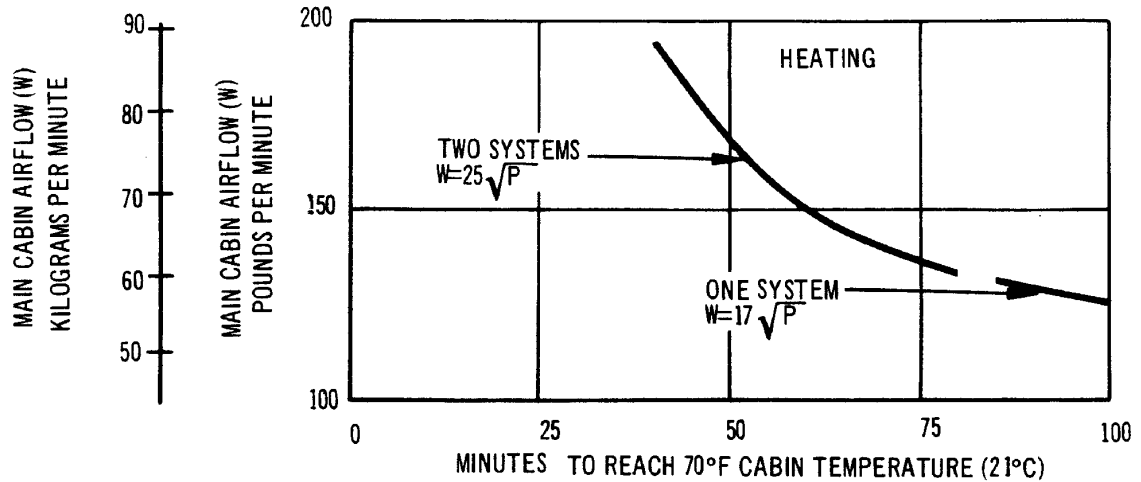

INITIAL CABIN TEMPERATURE AT 103°F (39.4°C). OUTSIDE AIR TEMPERATURE AT 103°F. SOLAR LOAD 5,500 BTU/HOUR (1,380 KG CAL/HOUR). NO GALLEY LOAD. NO CREW OR PASSENGERS. NO ELECTRICAL LOAD. TEMPERATURE AT GROUND CONNECTION IS 450°F (232.2°C).

NOTES:

- P = ABSOLUTE PRESSURE AT THE GROUND CONNECTION.
- ALL DOORS AND HATCHES CLOSED

AIR CONDITIONING REQUIREMENTS - PULL UP/PULL DOWN
 MODELS 707-320, -320B, -320C, -420

CONDITIONS:

- 1 CABIN AT 75°F (24° C). 130 PASSENGERS AND CREW. NO GALLEY LOAD. BRIGHT DAY SOLAR LOAD 5,000 BTU/HOUR (1,260 KG CAL./HOUR). ELECTRICAL LOAD 9,000 BTU/HOUR, (2,370 KG CAL./HOUR).
- 2 CABIN AT 80°F (26.7°C). ALL OTHER CONDITIONS SAME AS IN 1.
- 3 CABIN AT 70°F (21°C). THREE CREW MEMBERS ONLY. GALLEY LOAD 8,200 BTU/HOUR (2,060 KG CAL./HOUR). BRIGHT DAY SOLAR LOAD 5,500 BTU/HOUR (1,275 KG CAL./HOUR). ELECTRICAL LOAD 8,800 BTU/HOUR (2,220 KG CAL./HOUR).
- 4, 5 AND 6 CABIN AT 75°F (24°C) NO CREW OR PASSENGERS. NO OTHER HEAT LOAD.

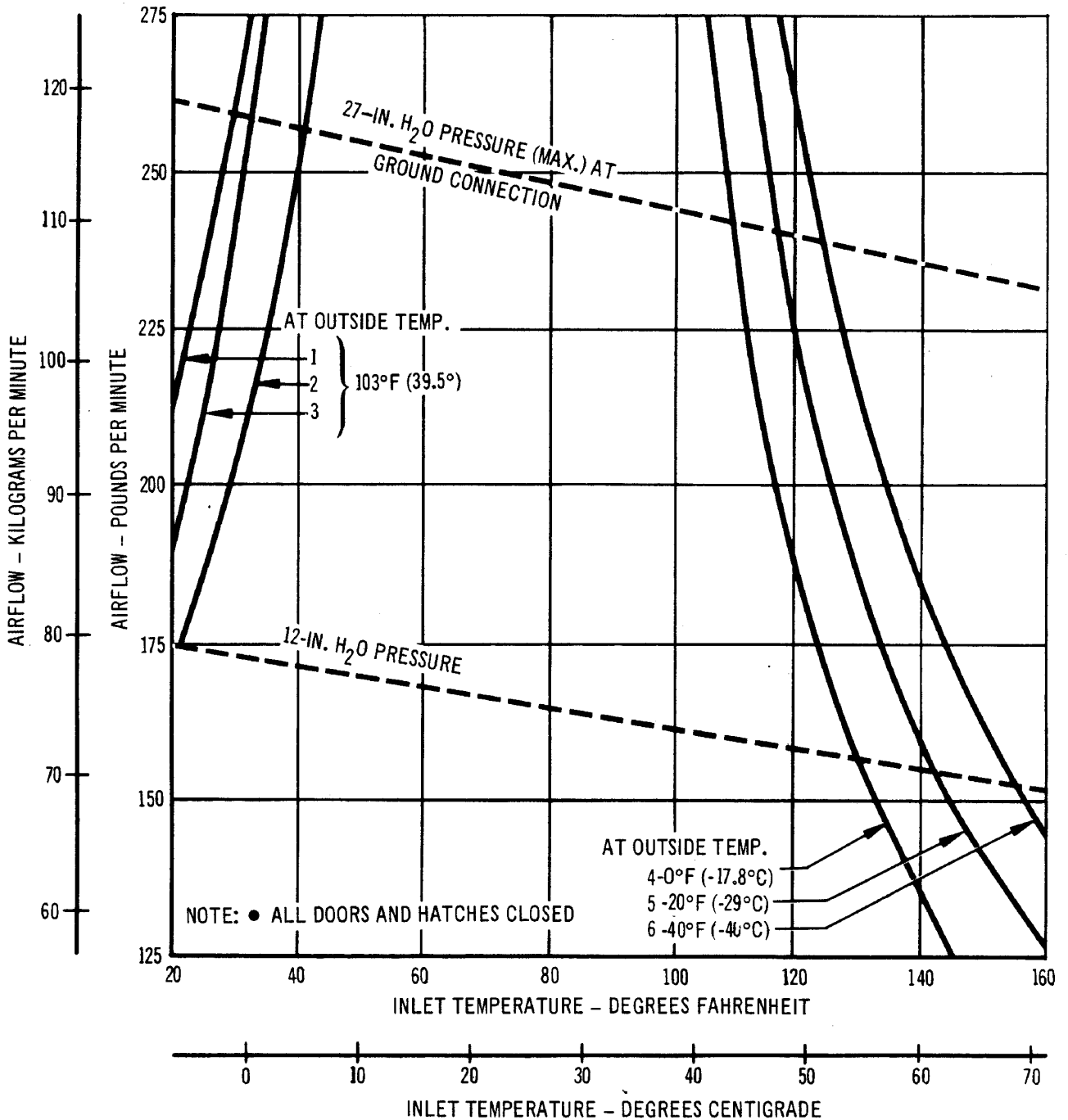

AIR CONDITIONING REQUIREMENTS - PRECONDITIONED AIRPLANE MODELS 707-320, -320B, -320C, -420

D6-58322

5.7 GROUND TOWING REQUIREMENTS

Ground towing requirements for various towing conditions are presented on pages 90 and 91.

Draw bar pull and total traction wheel load may be determined considering airplane weight, pavement slope and coefficient of friction and engine idle thrust.

EXAMPLE:

An example is illustrated on page 90 for the model 707 - 320C with a maximum taxi weight of 336,000 pounds and engines off (no engine thrust). Assuming the pavement to be wet concrete with zero slope, the required total traction wheel load would be 23,600 pounds; the draw bar pull would be 13,400 pounds. Note, when backing against idle thrust, these numbers would change to 29,000 and 16,500 pounds respectively.

- STRAIGHT LINE TOW
- UNUSUAL BREAKAWAY CONDITIONS NOT SHOWN
- ESTIMATED FOR RUBBER TIRED TOW VEHICLES
- COEFFICIENTS OF FRICTION μ APPROXIMATE

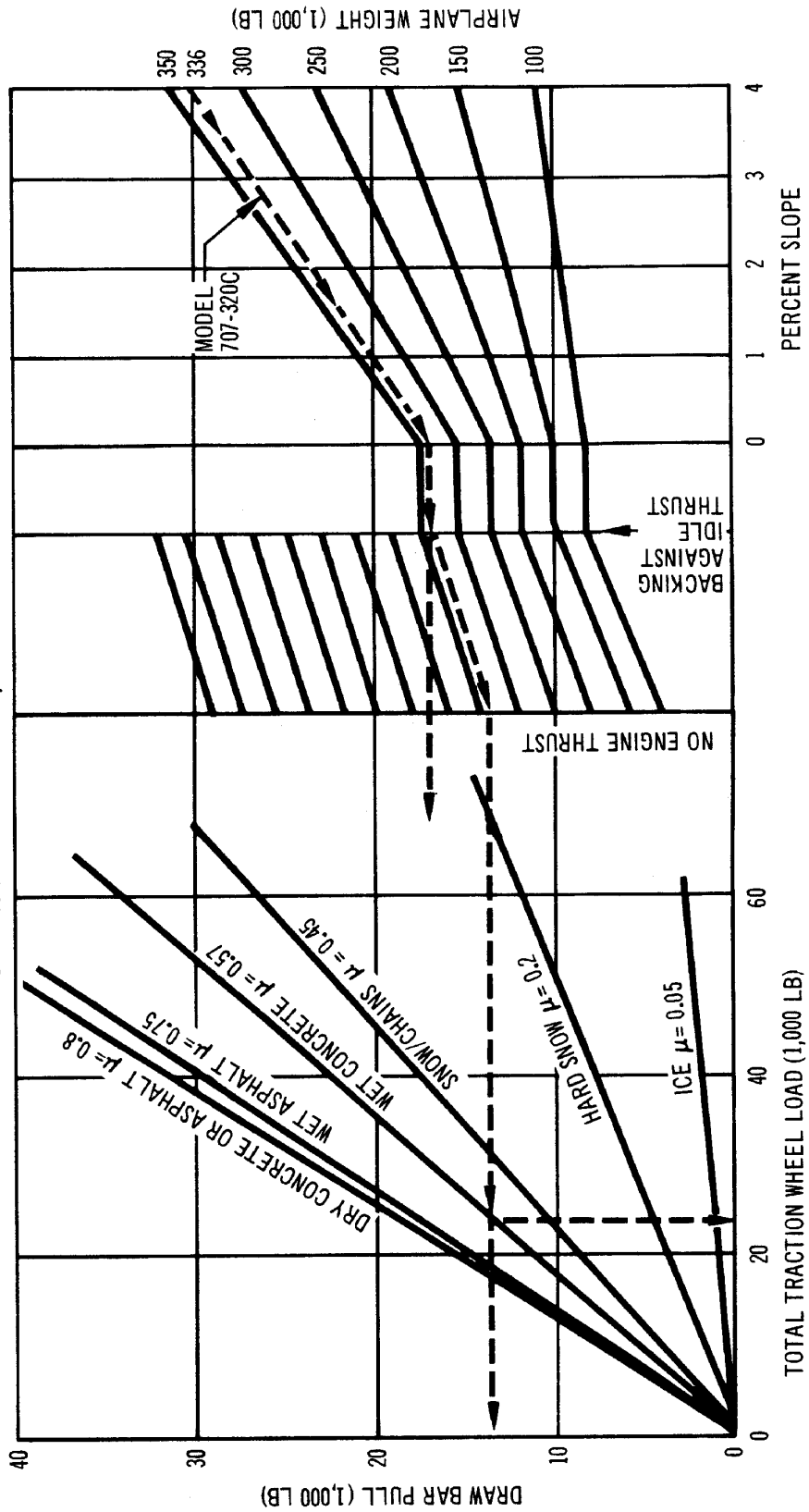

GROUND TOWING REQUIREMENTS
MODELS 707-120B, -320, -320B, -320C, -420

D6-58322

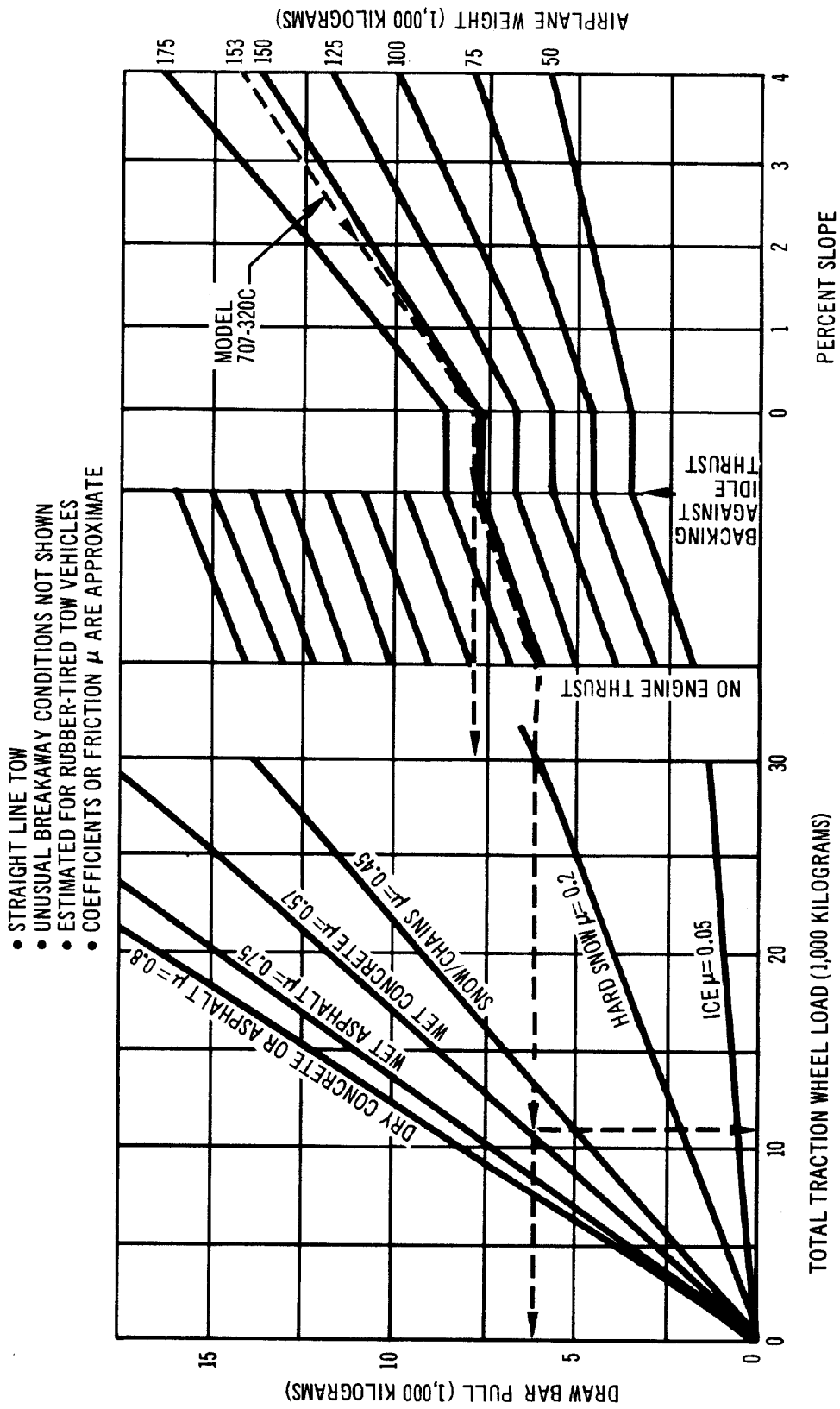

GROUND TOWING REQUIREMENTS - METRIC
 MODELS 707-120B, -320, -320B, -320C, -420

6.0 JET ENGINE WAKE AND NOISE DATA

6.1 Jet Engine Exhaust Velocities and Temperatures

6.2 Airport and Community Noise

- NOTES:
- JT3D ENGINE
 - DATA NOT VERIFIED BY TEST
 - CONDITIONS:
 - STANDARD DAY
 - SEA LEVEL
 - ZERO WIND
 - STATIC AIRPLANE

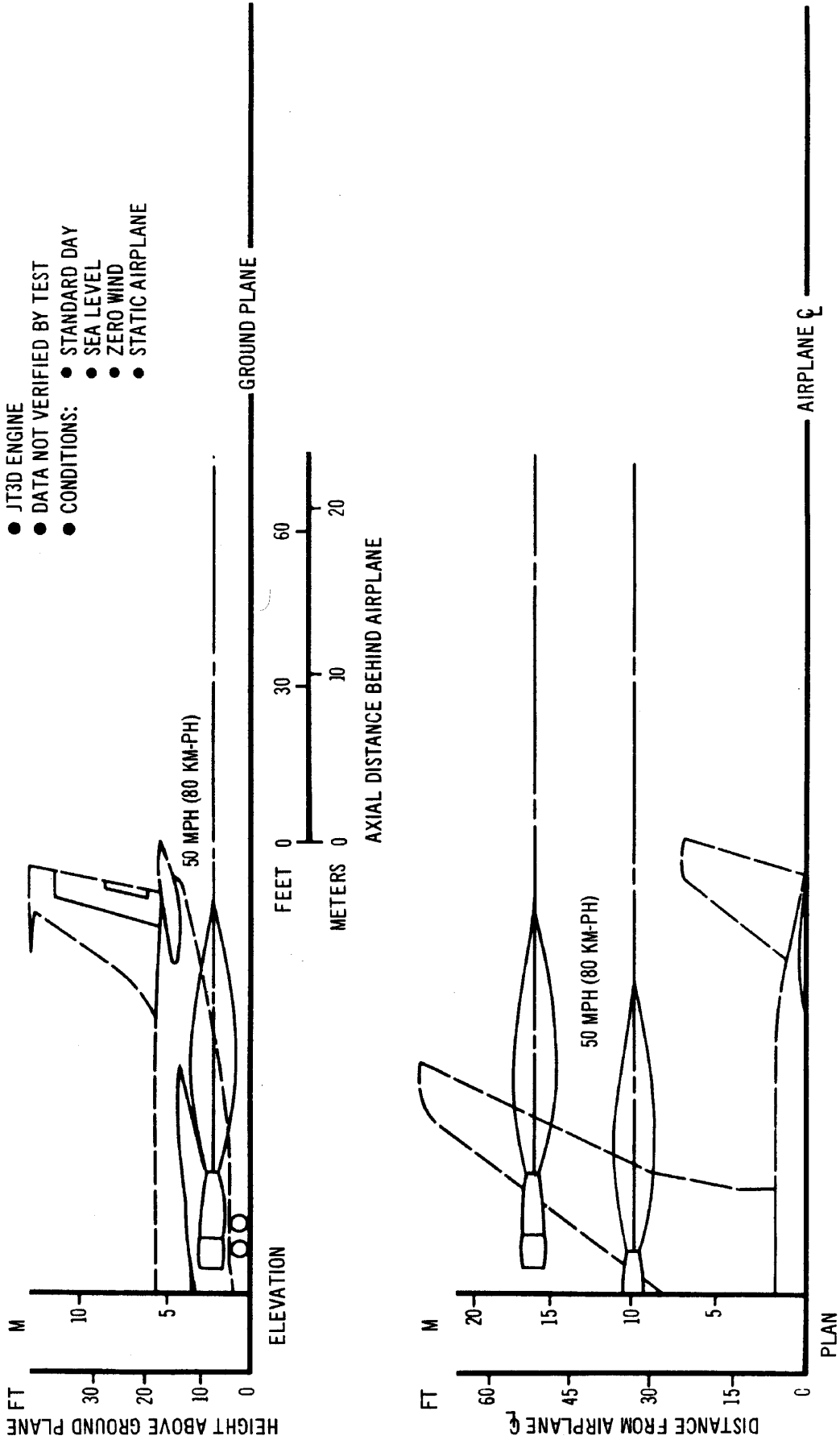

6.1 JET ENGINE EXHAUST - VELOCITY CONTOURS - IDLE POWER
 MODELS 707-120B, -320B, -320C

**JET ENGINE EXHAUST - TEMPERATURE CONTOURS - IDLE POWER
 MODELS 707-120B, -320B, -320C**

- NOTES:**
- JT3D ENGINE
 - DATA NOT VERIFIED BY TEST
 - CONDITIONS:
 - STANDARD DAY
 - SEA LEVEL
 - ZERO WIND
 - STATIC AIRPLANE

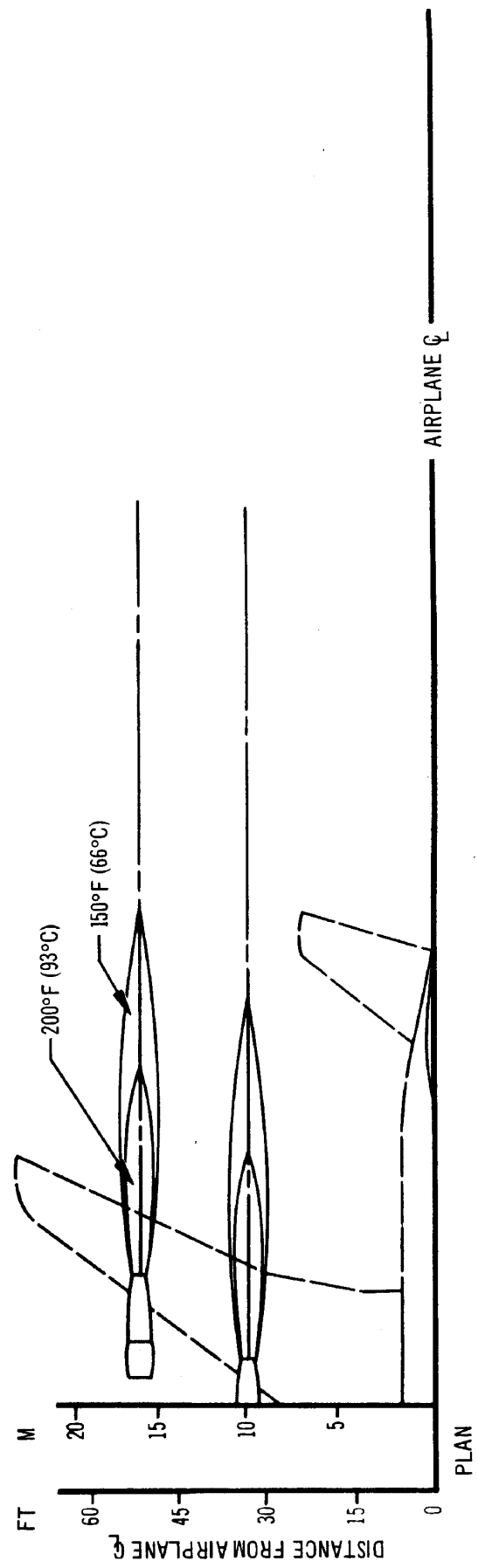
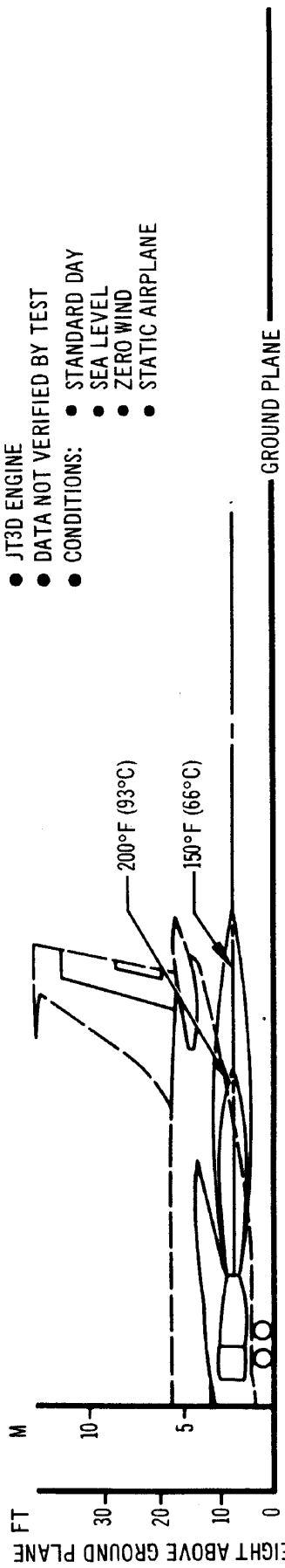

- NOTES:
- JT3D ENGINE
 - DATA NOT VERIFIED BY TEST
 - CONDITIONS:
 - STANDARD DAY
 - SEA LEVEL
 - ZERO WIND
 - STATIC AIRPLANE TO LEVEL
 - STRAIGHT AHEAD MOVEMENT

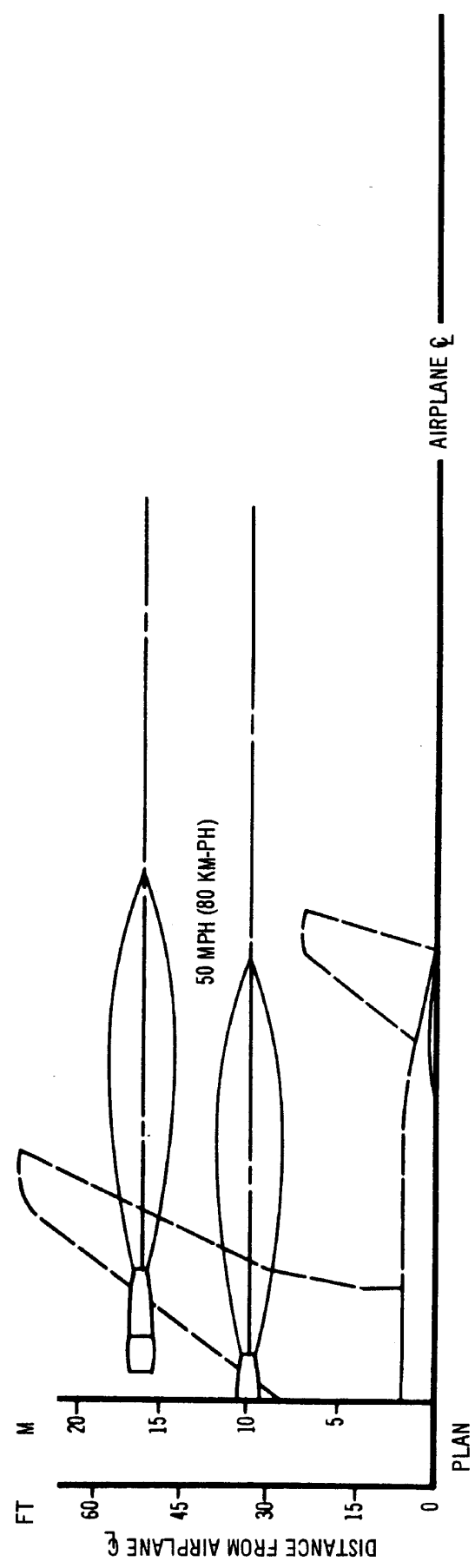
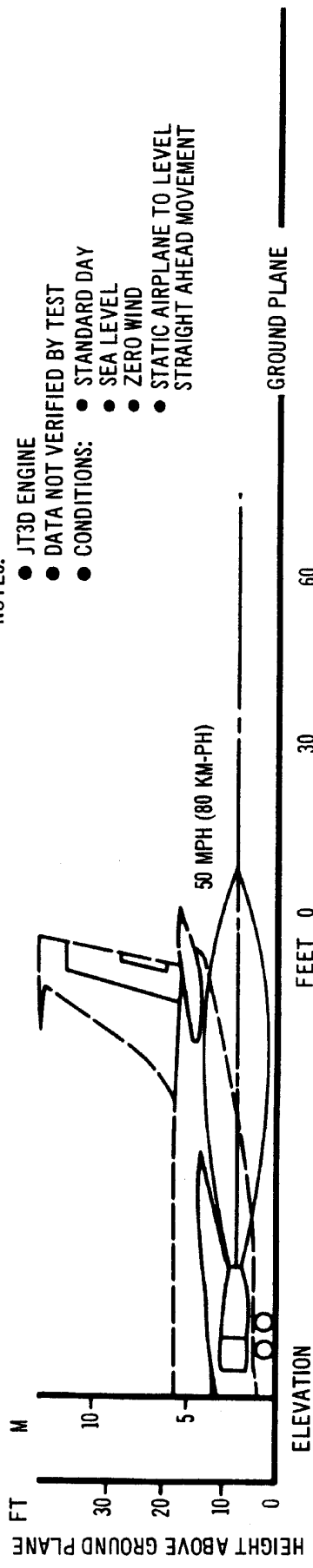

**JET ENGINE EXHAUST - VELOCITY CONTOURS - BREAKAWAY POWER
MODELS 707-120B, -320B, -320C**

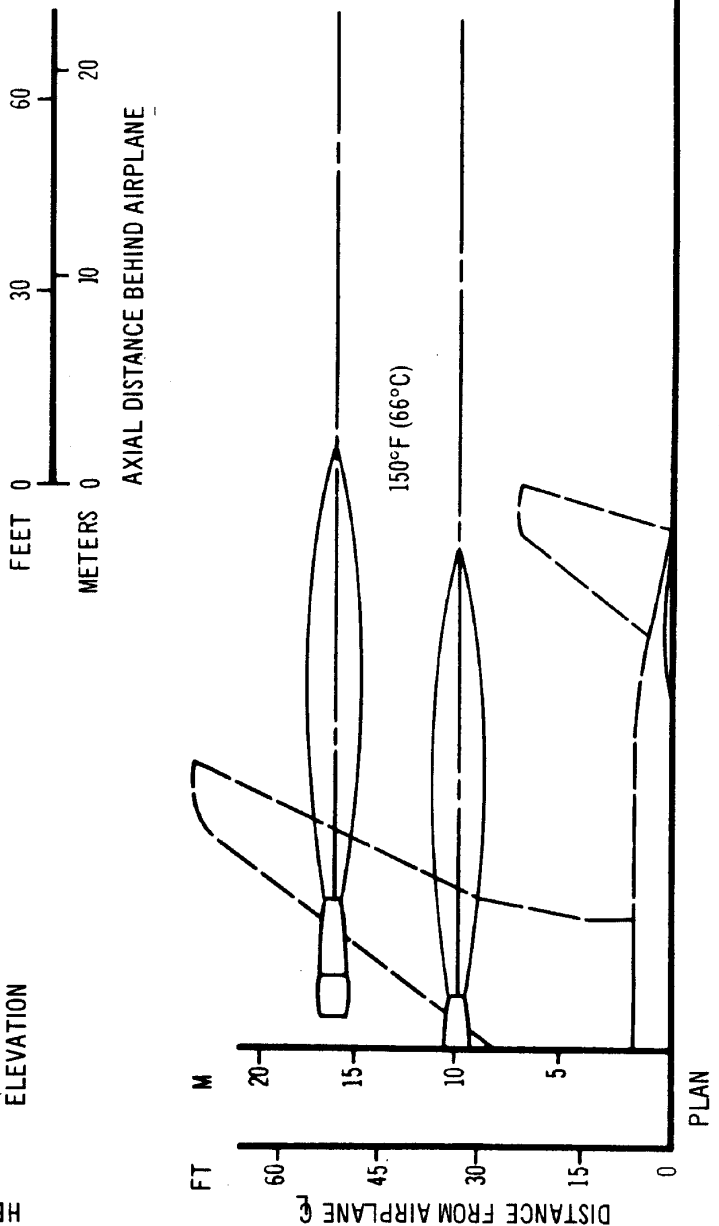
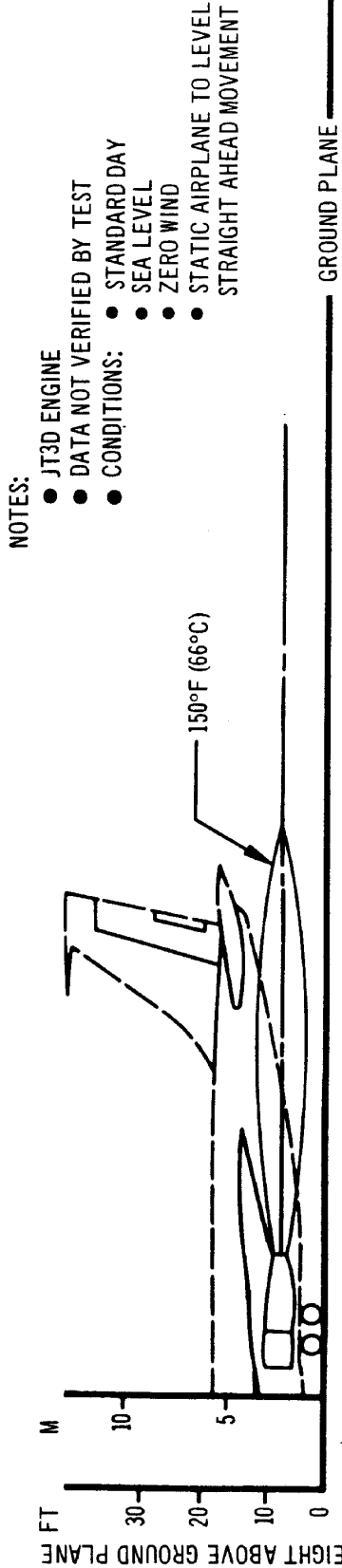

JET ENGINE EXHAUST - TEMPERATURE CONTOURS - BREAKAWAY POWER MODELS 707-120B, -320B, -320C

D6-58322

NOTES:

- JT3D ENGINE
- DATA NOT VERIFIED BY TEST
- CONDITIONS:
 - STANDARD DAY
 - SEA LEVEL
 - ZERO WIND
 - STATIC AIRPLANE

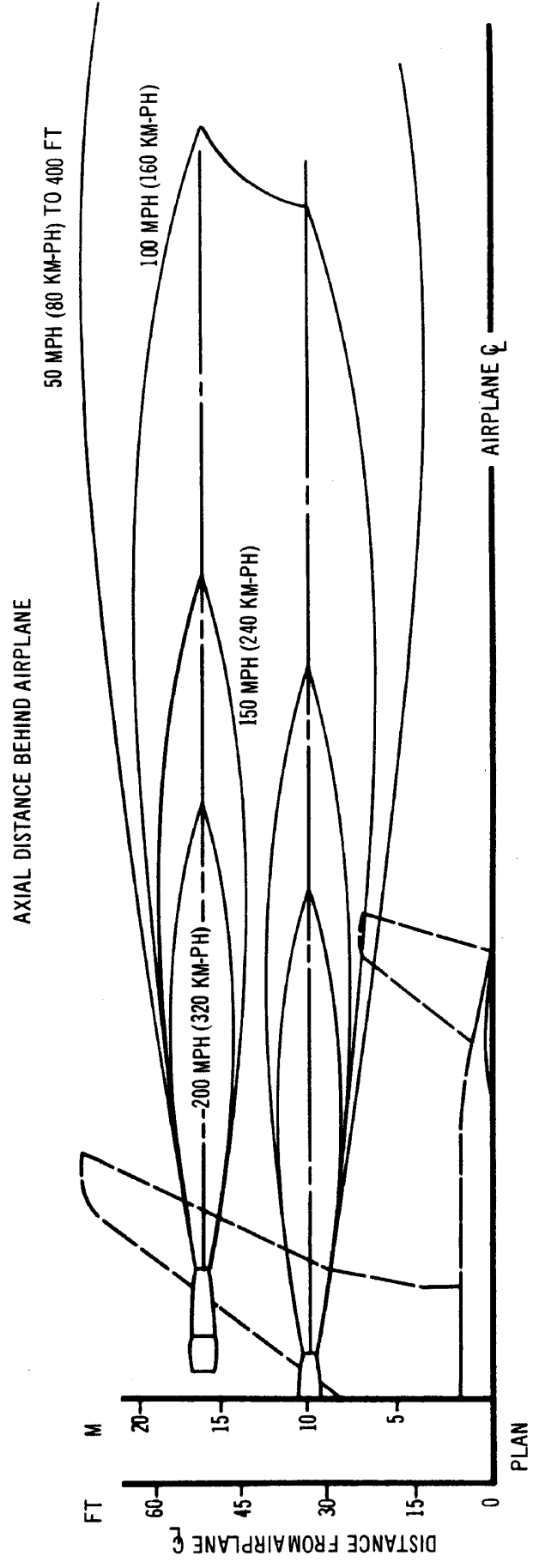
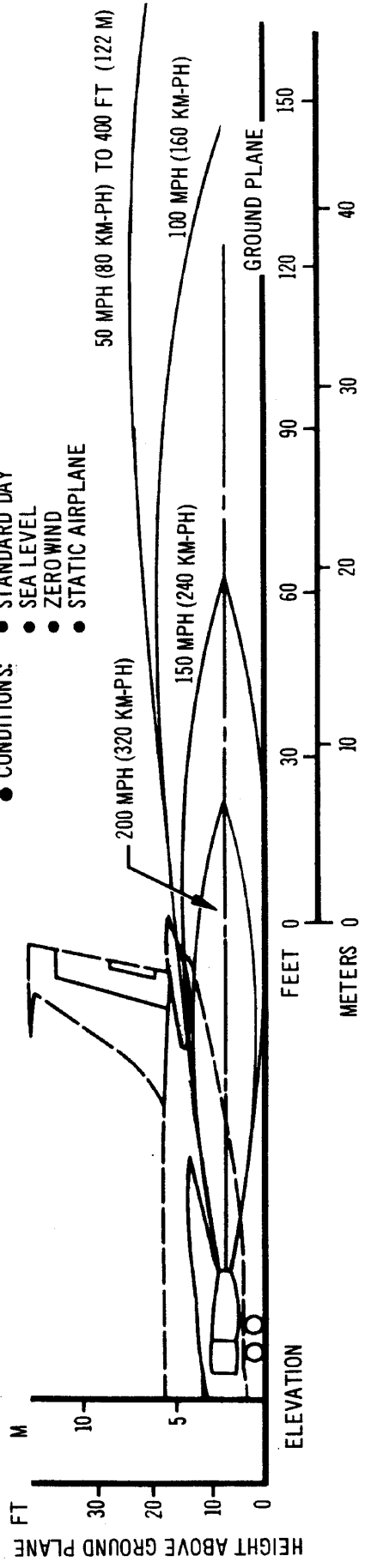

JET ENGINE EXHAUST - VELOCITY CONTOURS - MAXIMUM POWER
 MODELS 707-120B, -320B, -320C

**JET ENGINE EXHAUST - TEMPERATURE CONTOURS - MAXIMUM POWER
MODELS 707-120B, -320B, -320C**

- NOTES:**
- JT3D ENGINE
 - DATA NOT VERIFIED BY TEST
 - CONDITIONS:
 - STANDARD DAY
 - SEA LEVEL
 - ZERO WIND
 - STATIC AIRPLANE

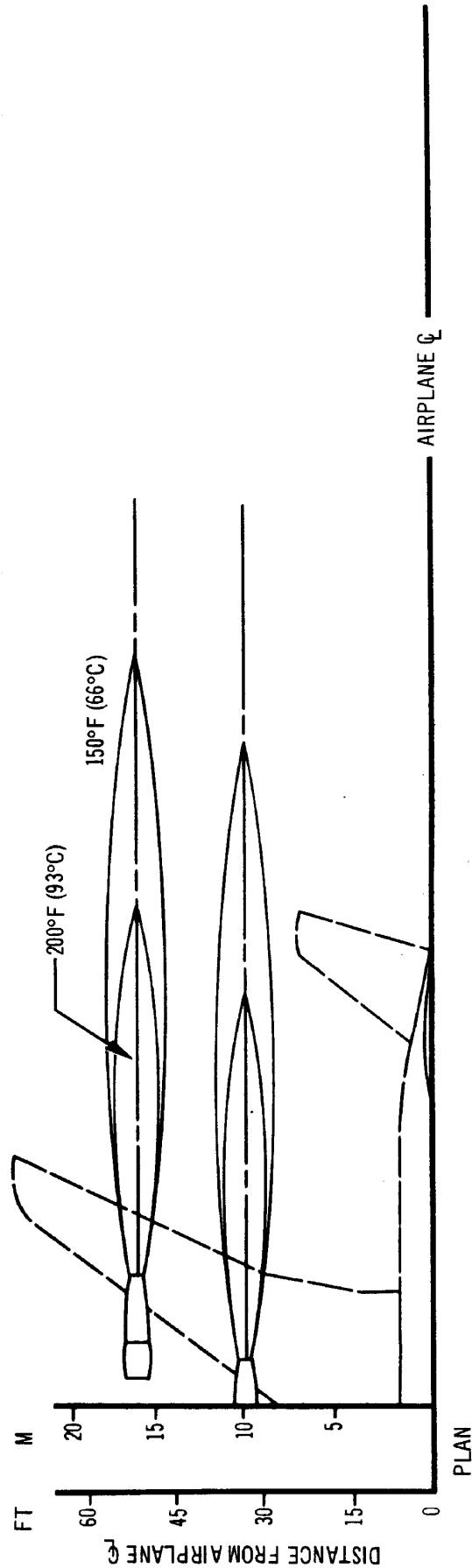
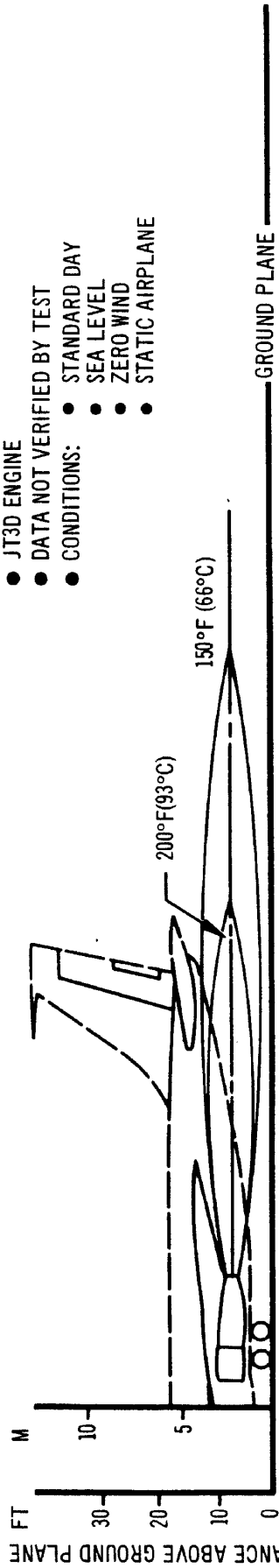

**JET ENGINE EXHAUST - VELOCITY CONTOURS - IDLE POWER
MODEL 707-320**

- NOTES:**
- JT4A ENGINE
 - DATA NOT VERIFIED BY TEST
 - CONDITIONS:
 - STANDARD DAY
 - SEA LEVEL
 - ZERO WIND
 - STATIC AIRPLANE

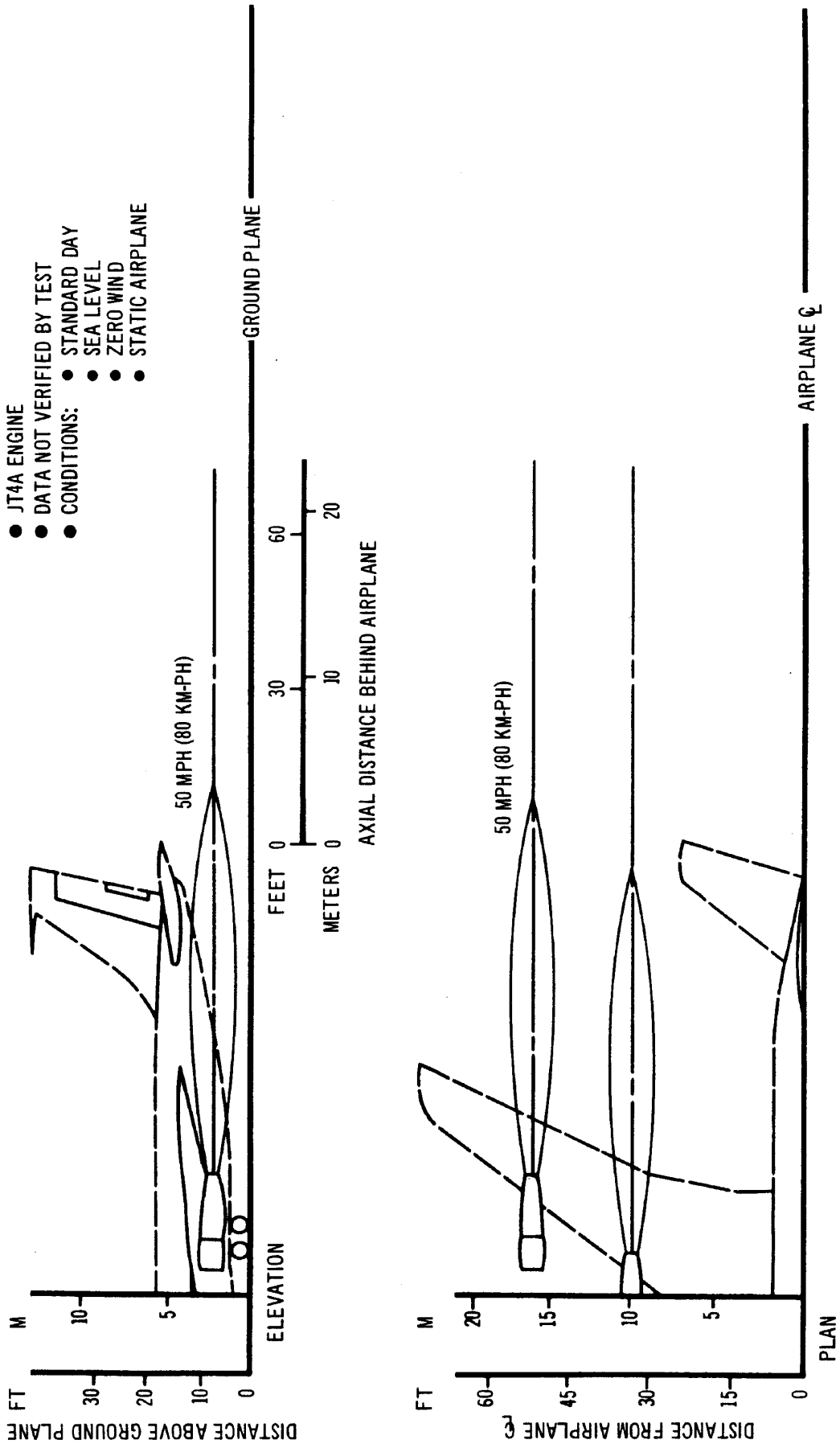

**JET ENGINE EXHAUST - TEMPERATURE CONTOURS - IDLE POWER
MODEL 707-320**

NOTES:

- JT4A ENGINE
- DATA NOT VERIFIED BY TEST
- CONDITIONS:
 - STANDARD DAY
 - SEA LEVEL
 - ZERO WIND
 - STATIC AIRPLANE

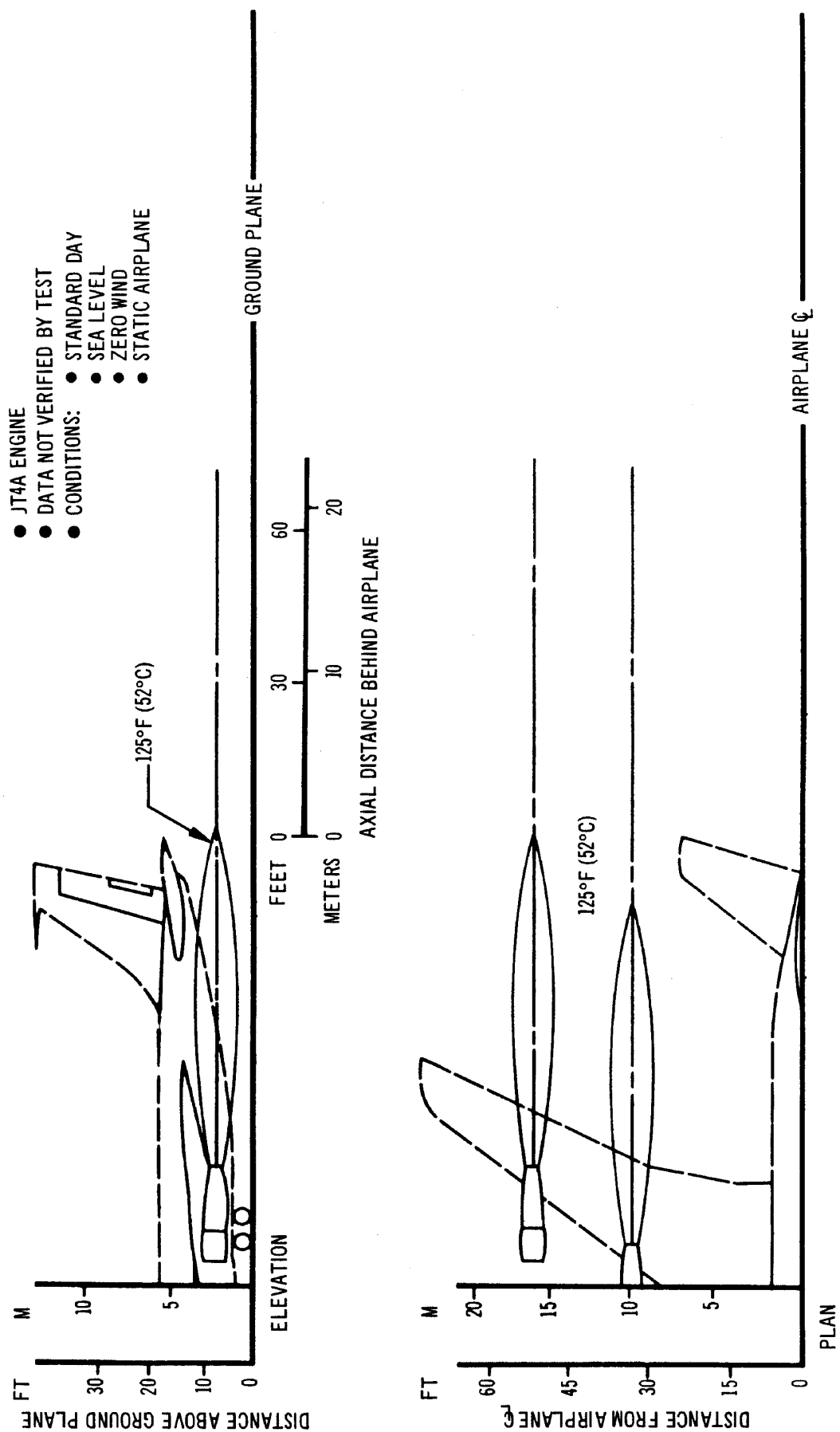

- NOTES:
- JT4A ENGINE
 - DATA NOT VERIFIED BY TEST
 - STANDARD DAY
 - SEA LEVEL
 - ZERO WIND
 - STATIC AIRPLANE TO LEVEL STRAIGHT AHEAD MOVEMENT

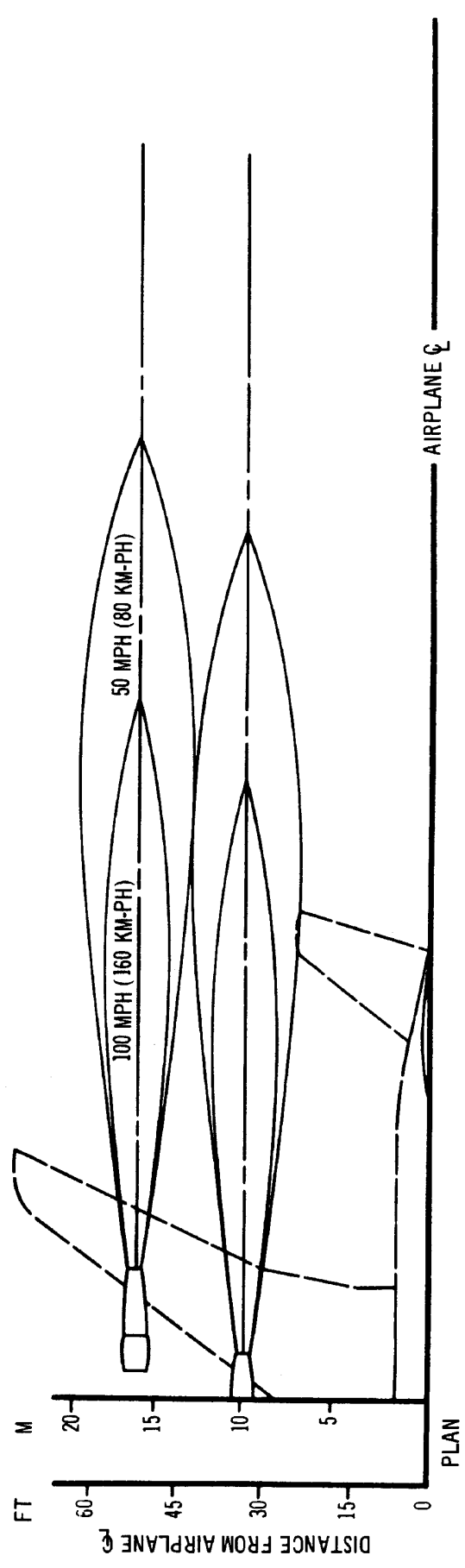
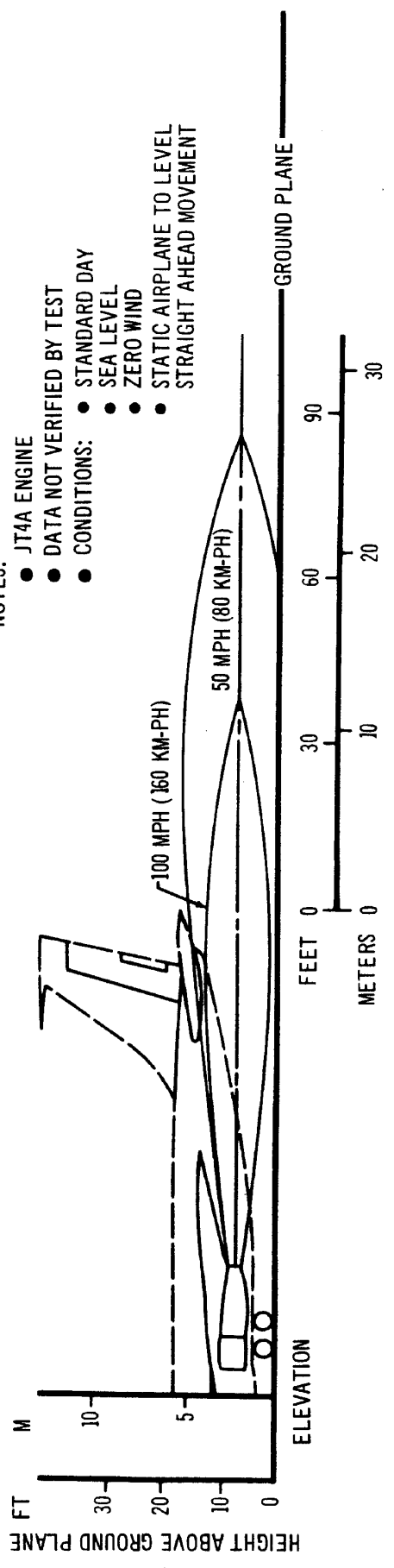

JET ENGINE EXHAUST - VELOCITY CONTOURS - BREAKAWAY POWER
MODEL 707-320

**JET ENGINE EXHAUST - TEMPERATURE CONTOURS - BREAKAWAY POWER
MODEL 707-320**

- NOTES:**
- JT4A ENGINE
 - DATA NOT VERIFIED BY TEST
 - CONDITIONS:
 - STANDARD DAY
 - SEA LEVEL
 - ZERO WIND
 - STATIC AIRPLANE TO LEVEL STRAIGHT AHEAD MOVEMENT

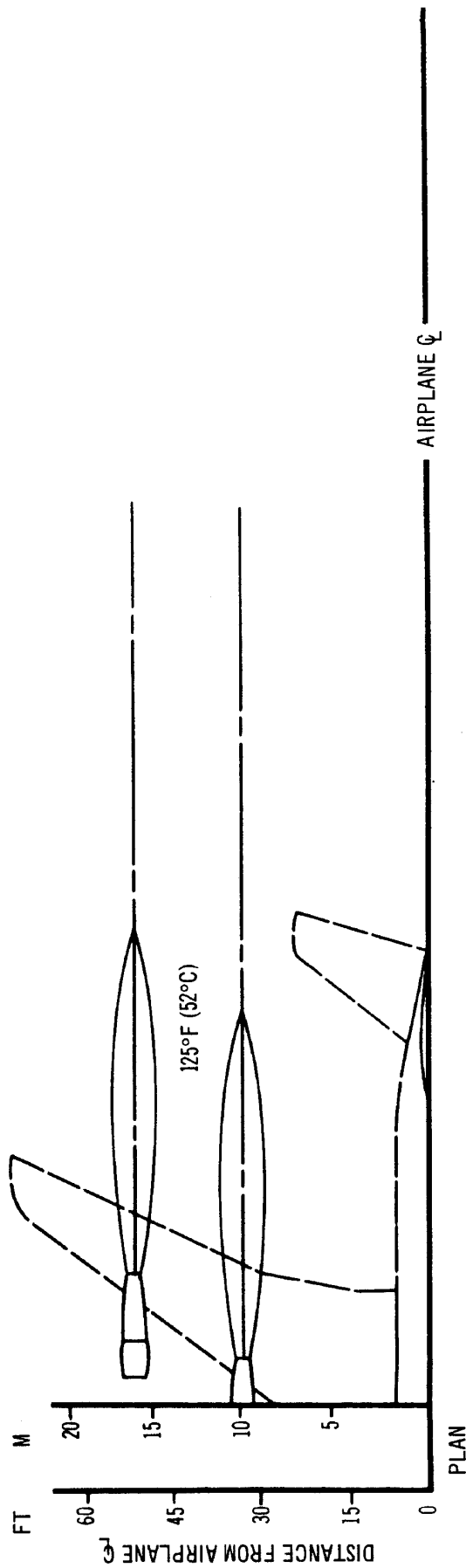
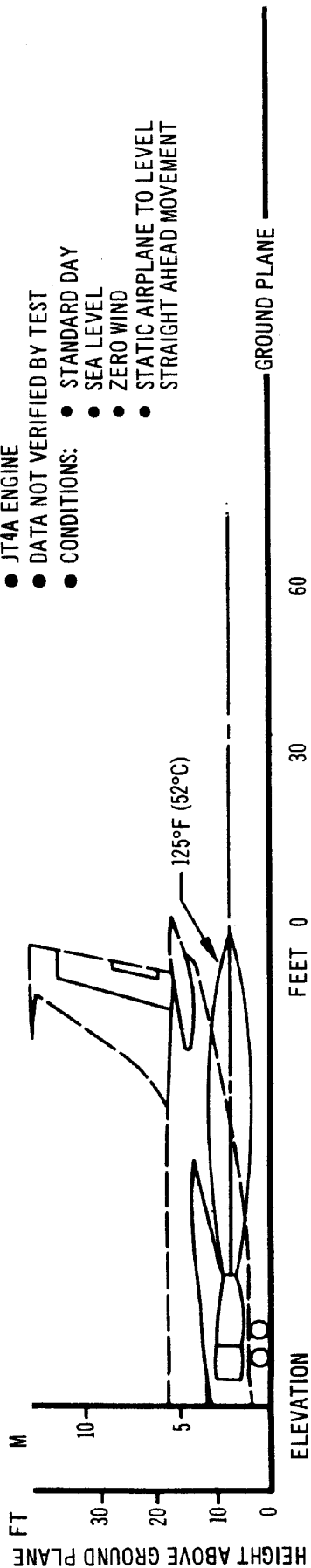

NOTES:

- JT4A ENGINE
- DATA NOT VERIFIED BY TEST
- CONDITIONS:
 - STANDARD DAY
 - SEA LEVEL
 - ZERO WIND
 - STATIC AIRPLANE

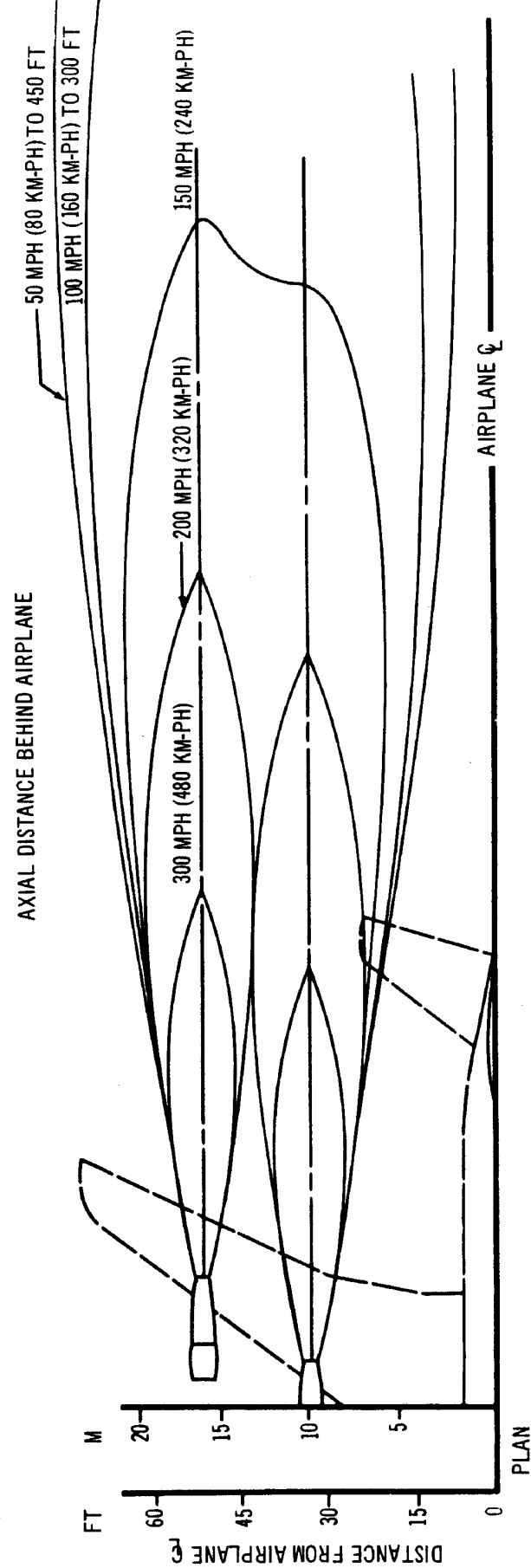
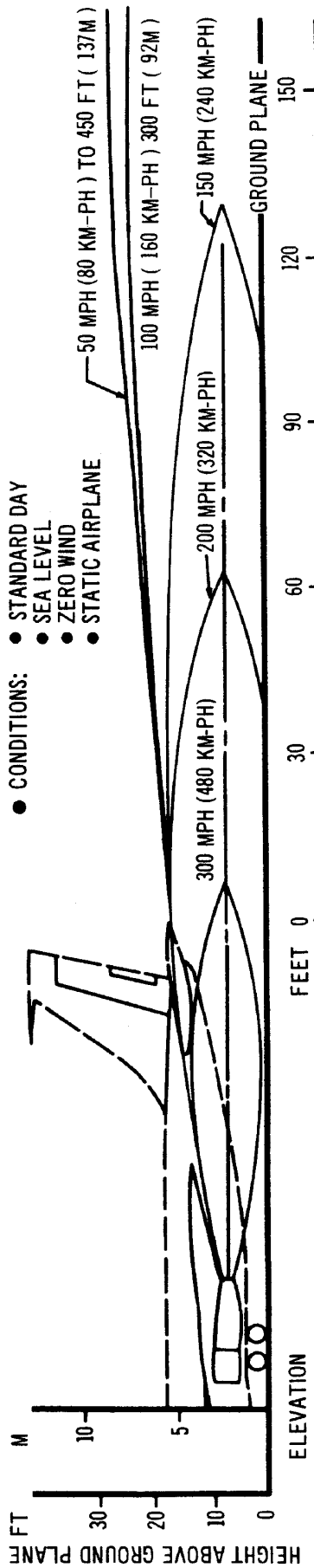

**JET ENGINE EXHAUST - VELOCITY CONTOURS - MAXIMUM POWER
MODEL 707-320**

**JET ENGINE EXHAUST - TEMPERATURE CONTOURS - MAXIMUM POWER
MODEL 707-320**

- NOTES:**
- JT4A ENGINE
 - DATA NOT VERIFIED BY TEST
 - CONDITIONS:
 - STANDARD DAY
 - SEA LEVEL
 - ZERO WIND
 - STATIC AIRPLANE

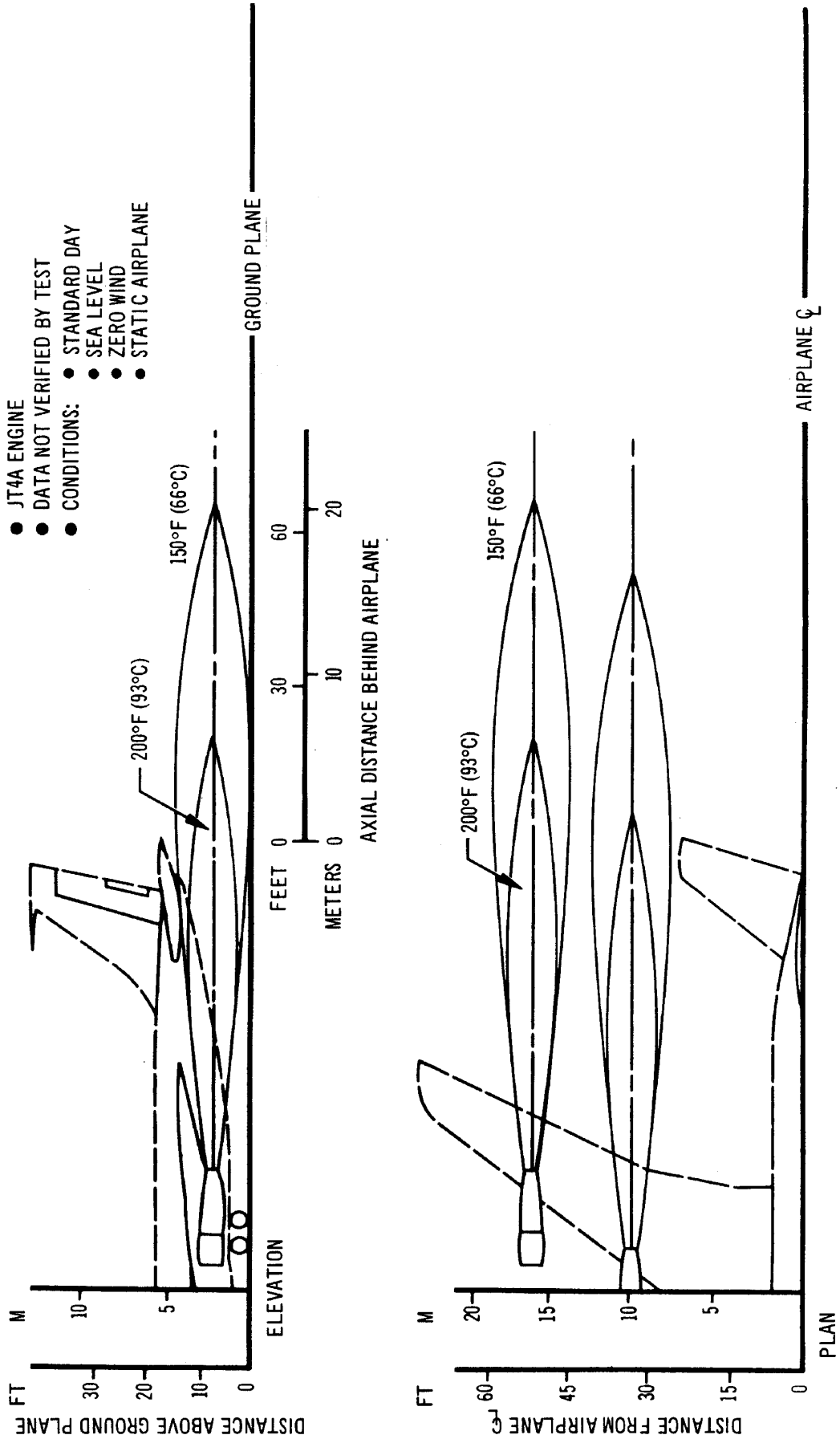

- NOTES:
- R. Co. -12 ENGINE
 - DATA NOT VERIFIED BY TEST
 - CONDITIONS:
 - STANDARD DAY
 - SEA LEVEL
 - ZERO WIND
 - STATIC AIRPLANE

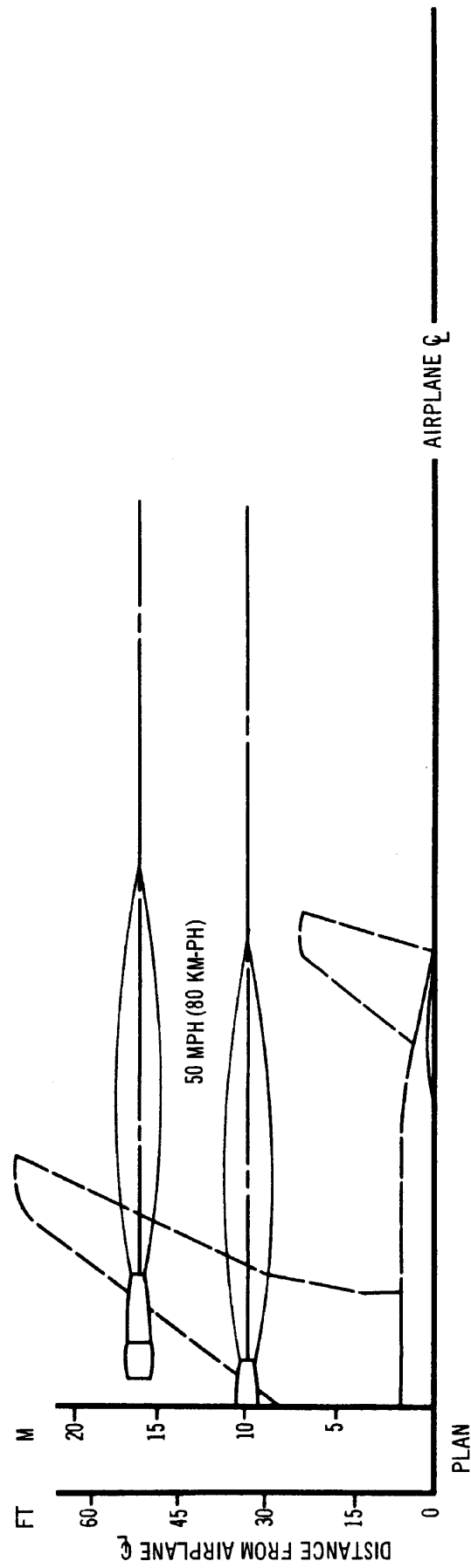
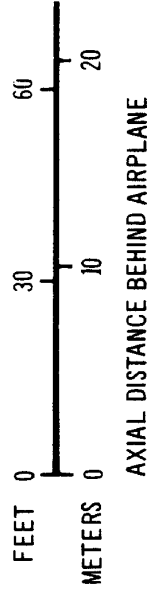
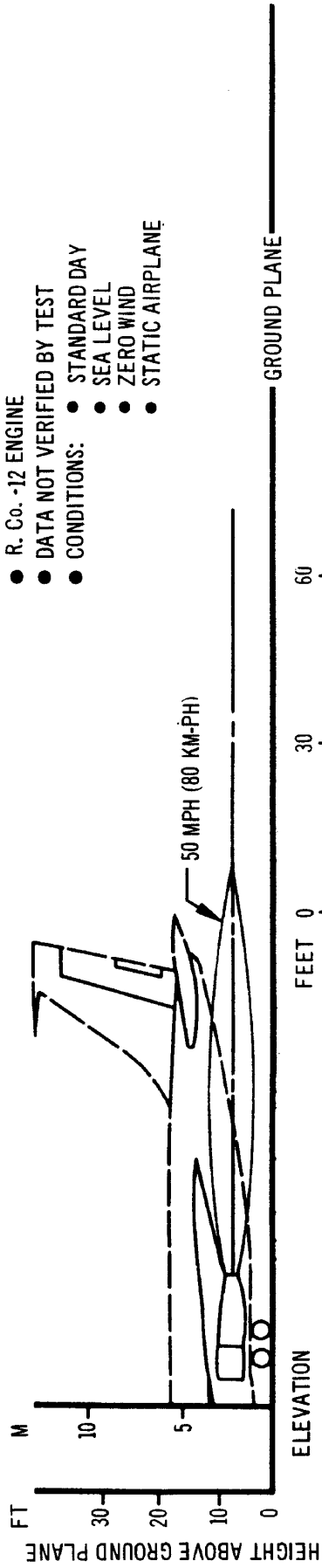

JET ENGINE EXHAUST - VELOCITY CONTOURS - IDLE POWER
MODEL 707-420

**JET ENGINE EXHAUST - TEMPERATURE CONTOURS - IDLE POWER
MODEL 707-420**

- NOTES:**
- R. Co. -12 ENGINE
 - DATA NOT VERIFIED BY TEST
 - CONDITIONS:
 - STANDARD DAY
 - SEA LEVEL
 - ZERO WIND
 - STATIC AIRPLANE

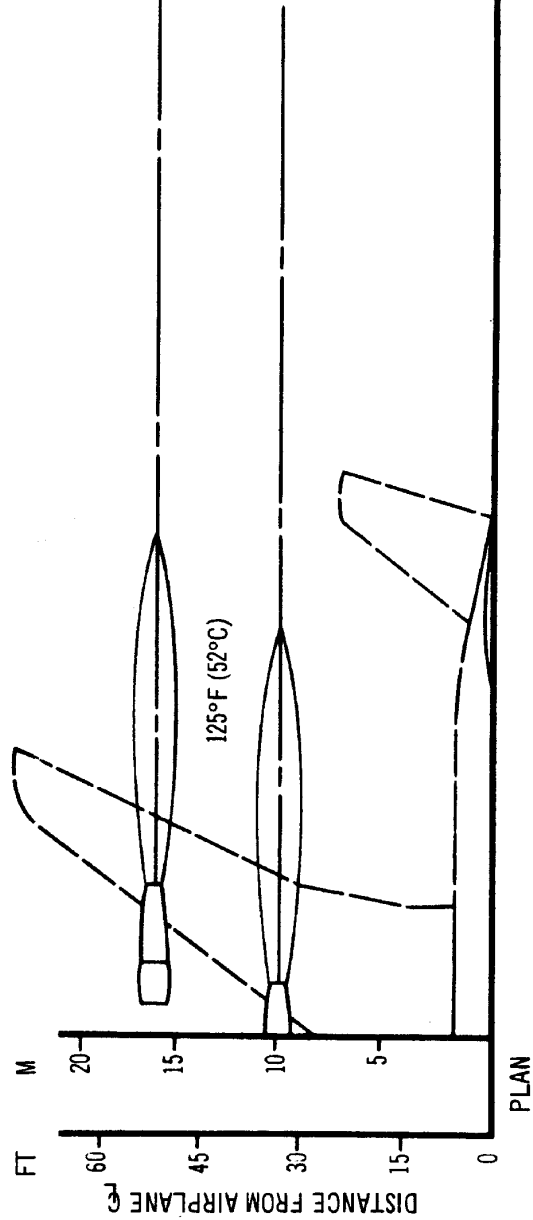
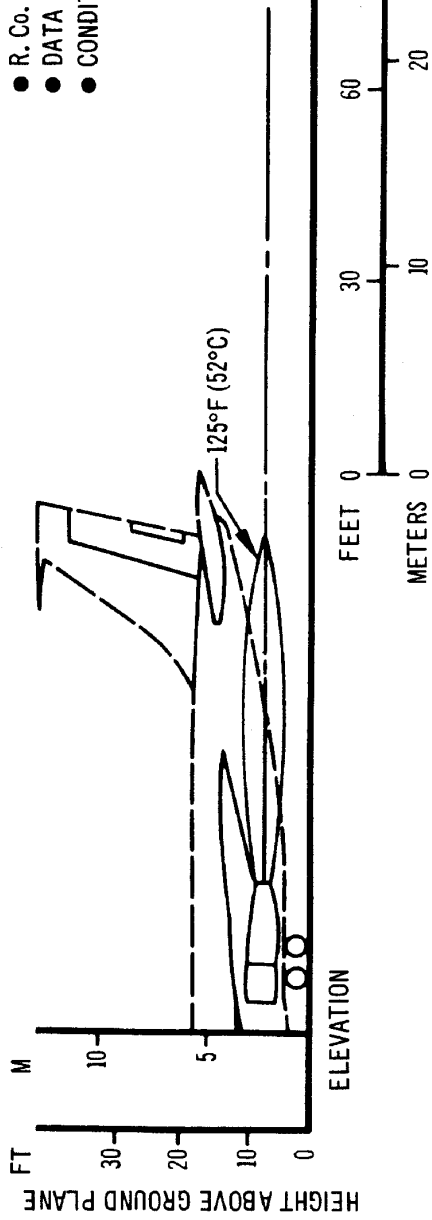

- NOTES:
- R. Co. -12 ENGINE
 - DATA NOT VERIFIED BY TEST
 - CONDITIONS:
 - STANDARD DAY
 - SEA LEVEL
 - ZERO WIND
 - STATIC AIRPLANE TO LEVEL
 - STRAIGHT AHEAD MOVEMENT

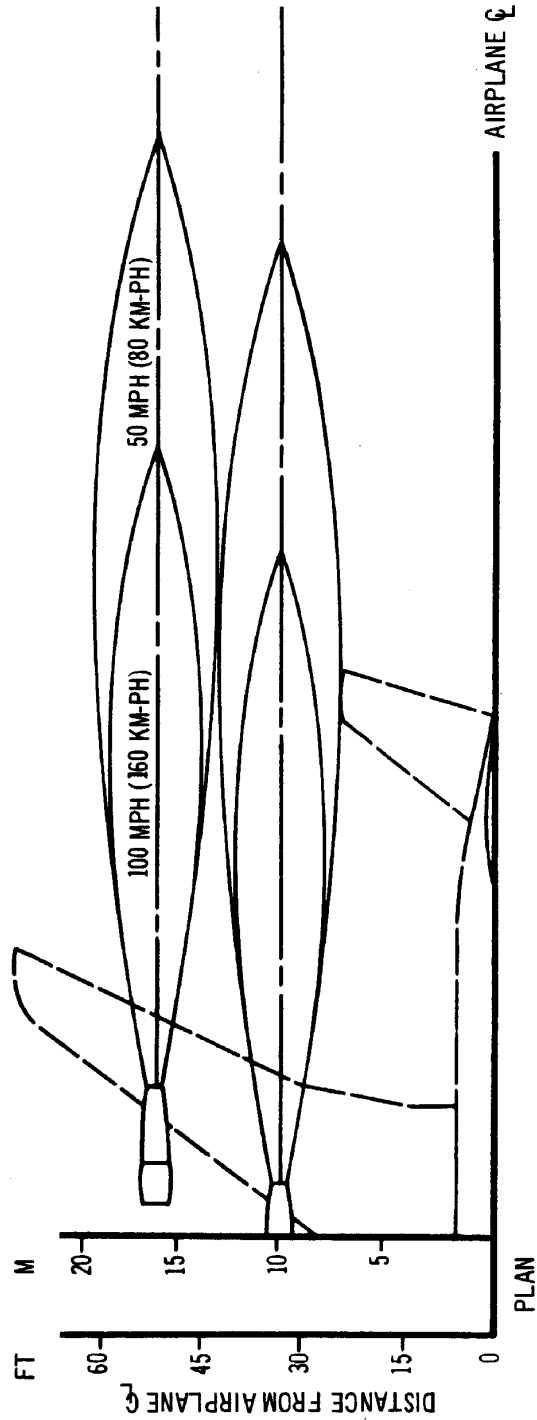
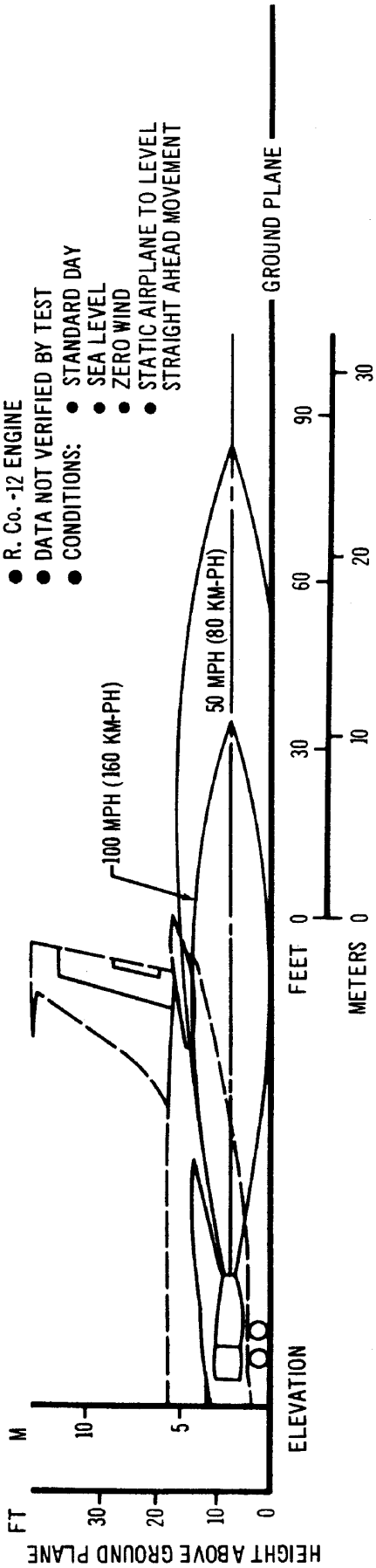

JET ENGINE EXHAUST - VELOCITY CONTOURS - BREAKAWAY POWER
 MODEL 707-420

**JET ENGINE EXHAUST - TEMPERATURE CONTOURS - BREAKAWAY POWER
MODEL 707-420**

- NOTES:**
- R. Co. -12 ENGINE
 - DATA NOT VERIFIED BY TEST
 - CONDITIONS:
 - STANDARD DAY
 - SEA LEVEL
 - ZERO WIND
 - STATIC AIRPLANE TO LEVEL
 - STRAIGHT AHEAD MOVEMENT

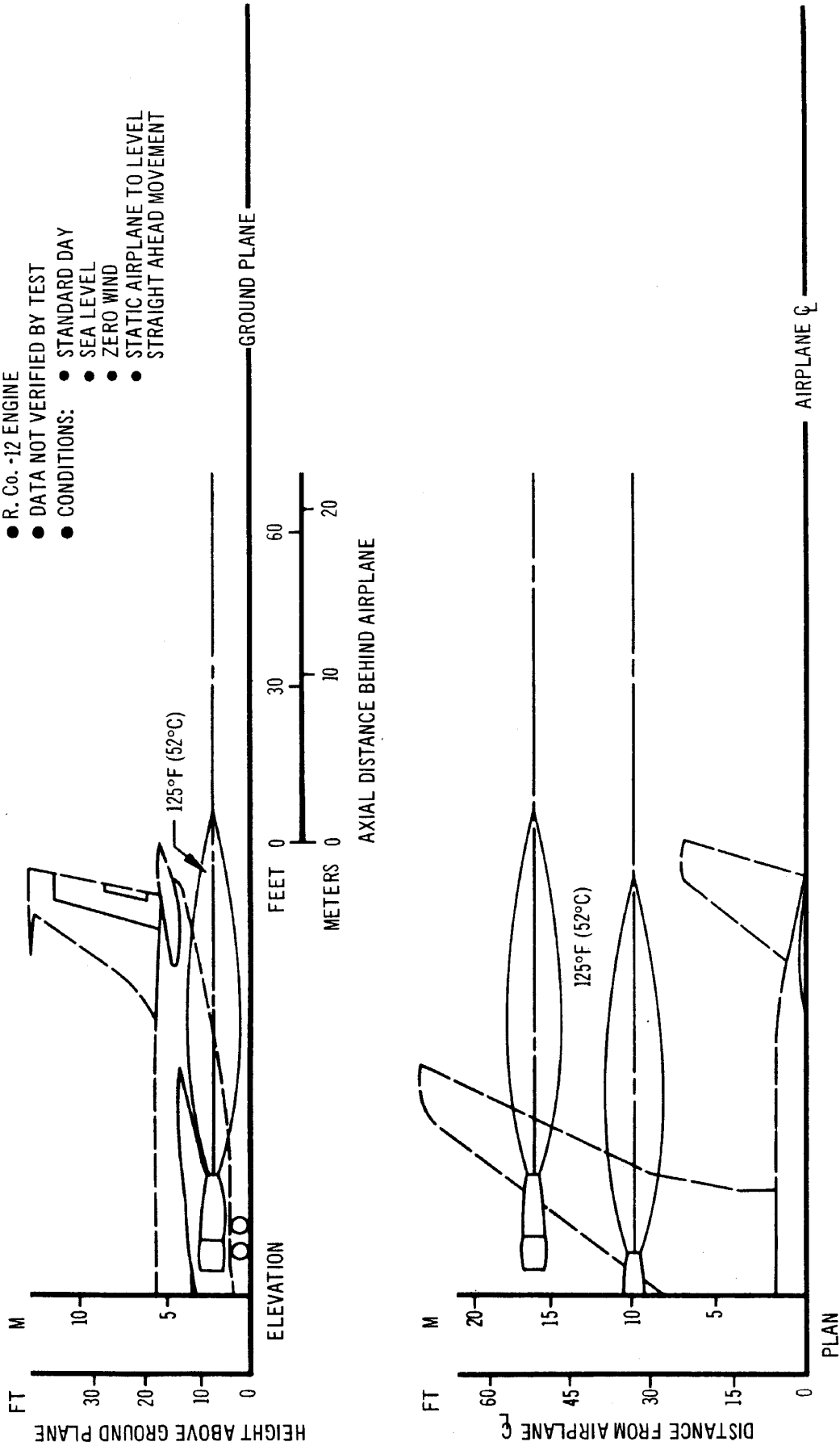

**JET ENGINE EXHAUST - VELOCITY CONTOURS - MAXIMUM POWER
MODEL 707-420**

NOTES:

- R. Co. -12 ENGINE
- DATA NOT VERIFIED BY TEST

- CONDITIONS:**
- STANDARD DAY
 - SEA LEVEL
 - ZERO WIND
 - STATIC AIRPLANE

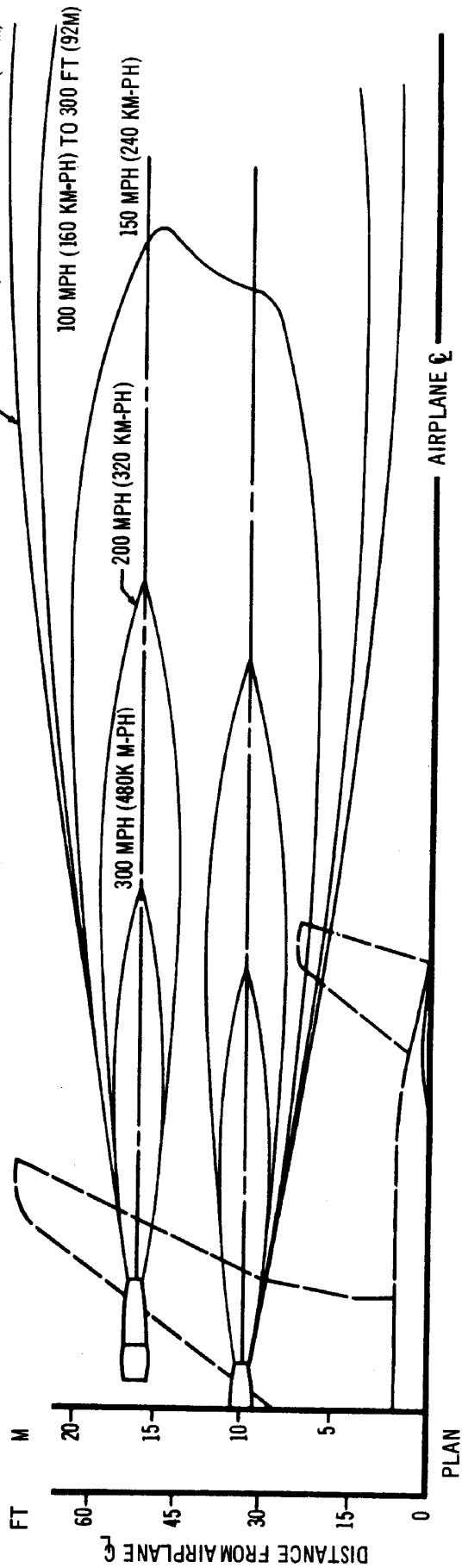
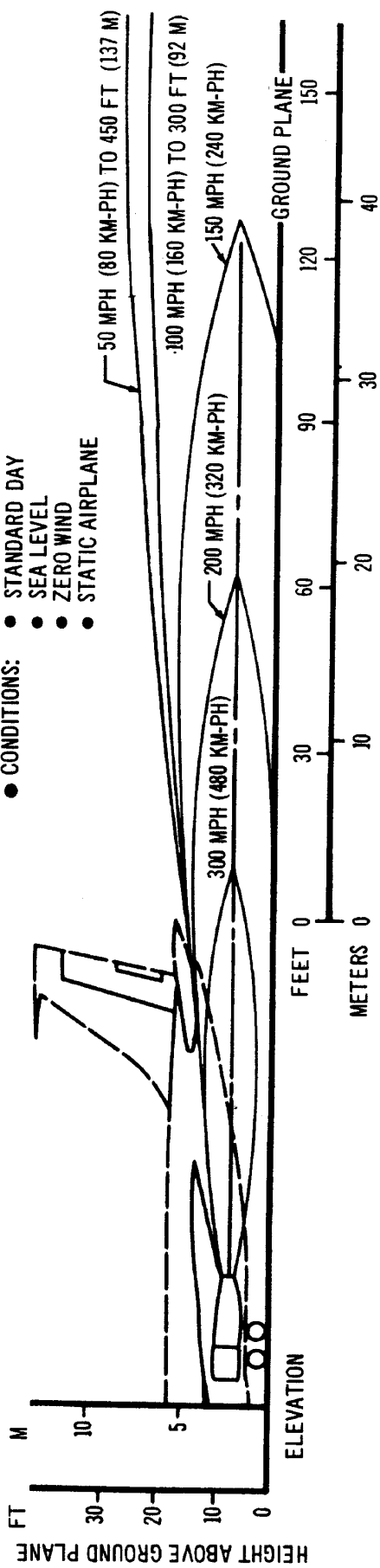

**JET ENGINE EXHAUST - TEMPERATURE CONTOURS - MAXIMUM POWER
MODEL 707-420**

- NOTES:**
- R. Co. -12 ENGINE
 - DATA NOT VERIFIED BY TEST
 - CONDITIONS:
 - STANDARD DAY
 - SEA LEVEL
 - ZERO WIND
 - STATIC AIRPLANE

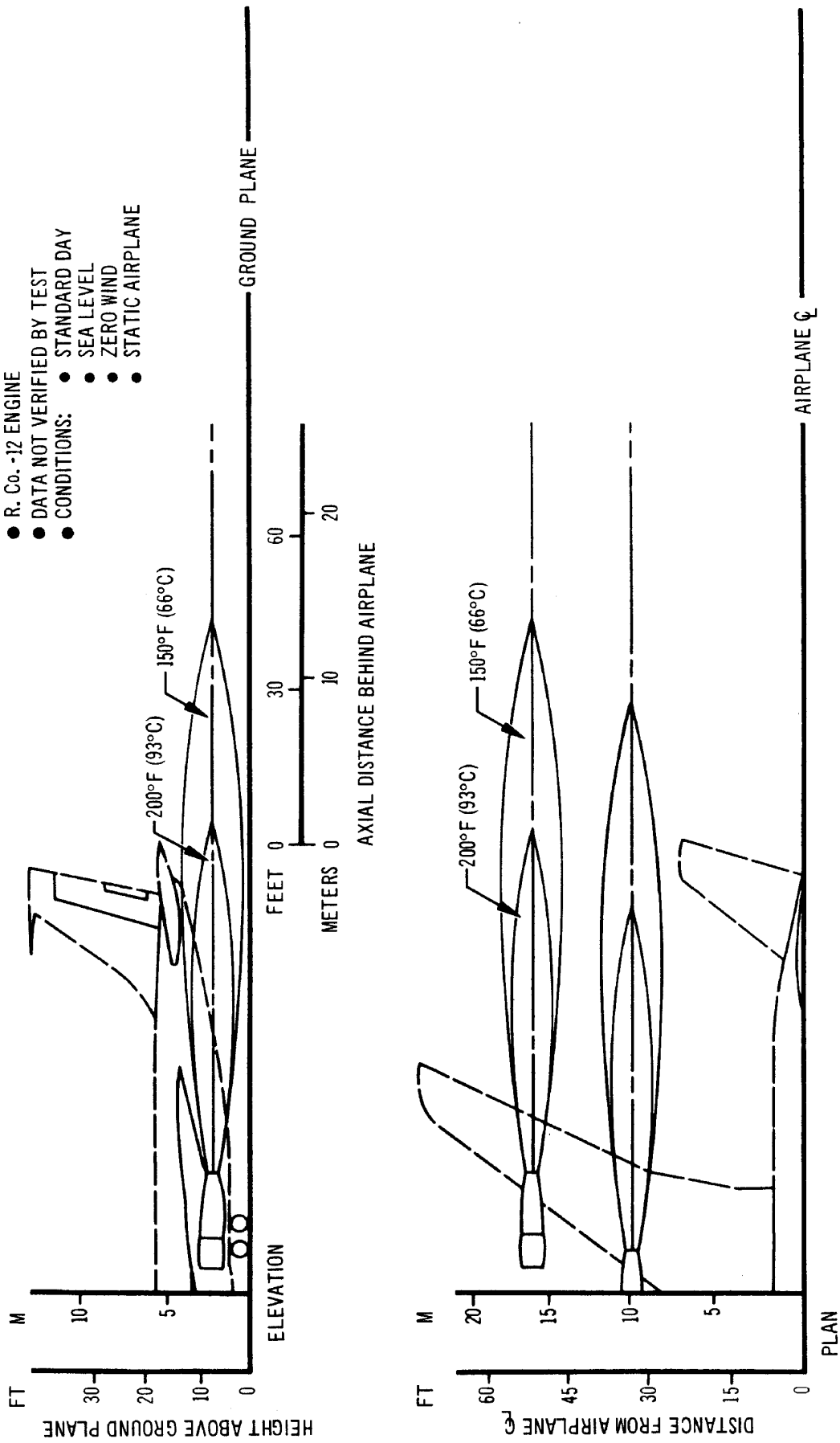

6.2 AIRPORT AND COMMUNITY NOISE

Noise level footprint contours will be developed and displayed in the document at some future date. These contours will reflect the noise level impingement upon a theoretical ground level plane at the same elevation as the runway. Contours will be provided for both takeoff and landing operations.

These footprint contours will permit investigations at individual airports of the noise associated with operation of the airplane as it relates to the airport proper and the adjoining community. This will assist in planning investigations related to clear zones, zoning for nonsensitive land utilization, or alternate compatible land development.

As an interim measure for airport planning it is recommended that FAA DS-67-14 "Techniques for Developing Noise Exposure Forecasts," with the exception of Section 4 "Land Use Planning," be used as representative of noise contours for 2, 3 and 4 engine airplanes. It must be kept in mind that the data presented is for effective perceived noise level in units of EPNdB, and as such must be considered to have a tolerance of ± 8 EPNdB.

- 7.0 PAVEMENT DATA**
 - 7.1 General Information**
 - 7.2 Landing Gear Footprint**
 - 7.3 Maximum Pavement Loads**
 - 7.4 Landing Gear Loading on Pavement**
 - 7.5 Flexible Pavement Requirements – SEFL 165A**
 - 7.6 Flexible Pavement Requirements - LCN Conversion**
 - 7.7 Rigid Pavement Requirements - Portland Cement Association Design Method**
 - 7.8 Rigid Pavement Requirements - LCN Conversion**
 - 7.9 Flexible and Rigid Pavement Requirements - FAA Design Method**
 - 7.10 ACN/PCN Reporting System - Flexible and Rigid Pavements**

7.0 PAVEMENT DATA

7.1 General Information

A brief description of the pavement charts that follow will help in their use for airport planning. Each airplane configuration is depicted with a minimum range of four loads imposed on the main landing gear to aid in interpolation between the discrete values shown. All curves for any single chart represent data based on rated loads and tire pressures considered normal and acceptable by current aircraft tire manufacturer's standards. Tire pressures, where specifically designated on tables and charts, are at values obtained under loaded conditions as certificated for commercial use.

Page 116 presents basic data on the landing gear footprint configuration, maximum design taxi loads, and tire sizes and pressures.

Maximum pavement loads for certain critical conditions at the tire-to-ground interface are shown on page 117.

Pavement requirements for commercial airplanes are customarily derived from the static analysis of loads imposed on the main landing gear struts. The chart on page 118 is provided in order to determine these loads throughout the stability limits of the airplane at rest on the pavement. These main landing gear loads are used as the point of entry to the pavement design charts, interpolating load values where necessary.

The flexible pavement design curves (Section 7.5) are based on procedures set forth in Instruction Report No. S-77-1, "Procedures for Development of CBR Design Curves," dated June 1977, and as modified according to the methods described in ICAO Aerodrome Design Manual, Part 3, Pavements, 2nd Edition, 1983, Section 1.1 (The ACN-PCN Method), and utilizing the alpha factors approved by ICAO in October 2007. Instruction Report No. S-77-1 was prepared by the U.S. Army Corps of Engineers Waterways Experiment Station, Soils and Pavements Laboratory, Vicksburg, Mississippi. The line showing 10,000 coverages is used to calculate Aircraft Classification Number (ACN).

Rigid pavement design curves (page 130) have been prepared with the use of the Westergaard equation in general accordance with the procedures outlined in the Design of Concrete Airport Pavement (1955 edition) by Robert G. Packard, published by the American Concrete Pavement Association, 3800 North Wilke Road, Arlington Heights, Illinois 60004-1268. These curves are modified to the format described in the Portland Cement Association publication XP6705-2, Computer Program for Airport Pavement Design (Program PDILB), 1968, by Robert G. Packard.

The following procedure is used to develop rigid pavement design curves such as those shown on page 123.

1. Having established the scale for pavement thickness to the left and the scale for allowable working stress to the right, an arbitrary load line is drawn representing the main landing gear maximum weight to be shown.
2. All values of the subgrade modulus (k-values) are then plotted as shown on page 123.
3. Additional load lines for the incremental values of weight on the main landing gear are then established on the basis of the curve for $k = 300$, already established.

All LCN Curves where shown have been plotted from data in the International Civil Aviation Organization (ICAO) Document 7920-AN/865/2, Aerodrome Manual, Part 2, "Aerodrome Physical Characteristics," 2nd Edition, 1965.

On the same charts showing LCN versus equivalent single wheel load, there are load plots for the 707 family of airplanes showing equivalent single wheel load versus pavement thickness (h) for flexible pavements and versus l (radius of relative stiffness) for rigid pavements.

Procedures and curves provided in the ICAO Aerodrome Manual - Part 2, Chapter 4 are used to determine equivalent single wheel loads for use in making LCN conversion of rigid pavement requirements.

Note: Pavement requirements are presented for loads, tires and tire pressures presently planned for certified commercial usage.

All curves represent data at a constant specified tire pressure.

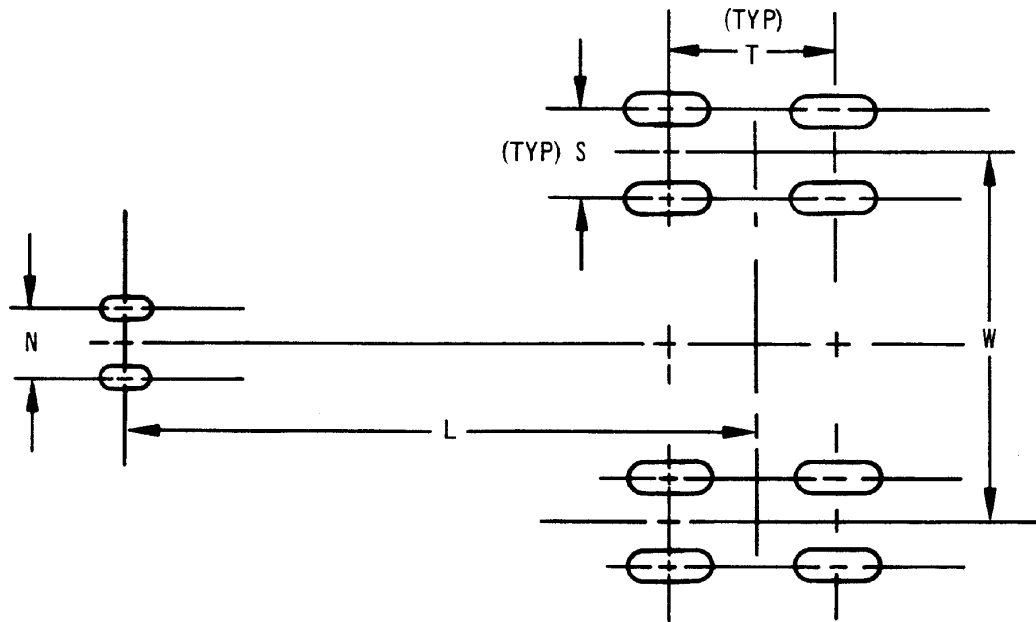

MODEL	MAXIMUM RAMP WEIGHT	PERCENT OF WEIGHT ON MAIN GEAR	NOSE TIRE SIZE	NOSE TIRE PRESSURE	MAIN GEAR TIRE SIZE	MAIN GEAR TIRE PRESSURE	L	N	S	T	W
707-120B	258,000 LB 117,100 KG	SEE PAGE (118)	(2) 39 X 13	90 PSI 6.34 KG/CM ²	(8) 46 X 16	170 PSI 11.95 KG/CM ²	52 FT 4 IN. 15.95M	1 FT 10 IN. 0.56M	2 FT 10 IN. 0.86 M	4 FT 8 IN. 1.42 M	22 FT 1.2 IN. 6.74 M
707-320, -420	316,000 LB 143,000 KG	SEE PAGE (119)	(2) 39 X 13	115 PSI 8.10 KG/CM ²	(8) 46 X 16	180 PSI 12.68 KG/CM ²	59 FT 0 IN. 17.98M	1 FT 10 IN. 0.56 M	2 FT 10.6 IN. 0.88 M	4 FT 8 IN. 1.42 M	22 FT 1.2 IN. 6.74 M
707-320B	328,000 LB 148,500 KG	SEE PAGE (120)	(2) 39 X 13	115 PSI 8.10 KG/CM ²	(8) 46 X 16	180 PSI 12.68 KG/CM ²	59 FT 0 IN. 17.98 M	1 FT 10 IN. 0.56 M	2 FT 10.6 IN. 0.88 M	4 FT 8 IN. 1.42 M	22 FT 1.2 IN. 6.74 M
707-320C	336,000 LB 152,500 KG	SEE PAGE (121)	(2) 39 X 13	115 PSI 8.10 KG/CM ²	(8) 46 X 16	180 PSI 12.68 KG/CM ²	59 FT 0 IN. 17.98 M	1 FT 10 IN. 0.56 M	2 FT 10.6 IN. 0.88 M	4 FT 8 IN. 1.42 M	22 FT 1.2 IN. 6.74 M

7.2 LANDING GEAR FOOTPRINT
MODELS 707-120B, -320, -320B, -320C, -420

LEGEND:

V_{NG} = MAXIMUM VERTICAL NOSE GEAR GROUND LOAD AT MOST FORWARD C.G.

V_{MG} = MAXIMUM VERTICAL MAIN GEAR GROUND LOAD AT MOST AFT C.G.

H = MAXIMUM HORIZONTAL GROUND LOAD FROM BRAKING

NOTE: ALL LOADS CALCULATED USING AIRPLANE MAXIMUM GROSS WEIGHT

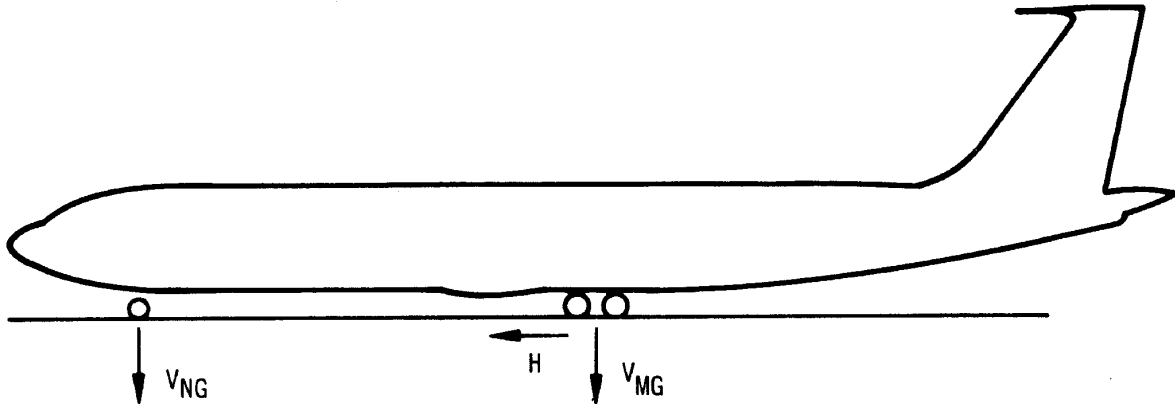

MODEL	MAXIMUM GROSS WEIGHT	V_{NG}				V_{MG} PER STRUT (2)		H (PER STRUT (2))			
		STATIC AT MOST FORWARD C.G.		STATIC + BRAKING @ 10 FT/SEC ² DECEL.		MAXIMUM LOAD OCCURRING AT STATIC AFT C.G.		AT STEADY BRAKING 10 FT/SEC ² DECEL		AT INSTANTANEOUS BRAKING (COEFF. OF FRICTION 0.8)	
		LB	KG	LB	KG	LB	KG	LB	KG	LB	KG
707-120B	258,000	26,600	12,070	40,880	18,560	120,600	54,750	40,100	18,200	96,500	43,810
707-320, -120	316,000	34,100	15,480	49,280	22,370	145,500	66,060	49,100	22,290	116,250	52,780
707-320B	328,000	34,400	15,620	50,100	22,750	151,000	68,550	51,000	23,150	120,750	54,820
707-320C	336,000	34,600	15,700	51,770	23,500	157,000	71,280	52,150	23,630	125,500	56,930

7.3 MAXIMUM PAVEMENT LOADS
MODELS 707-120B, -320, -320B, -320C, -420

NOTE: UNSHADED AREA REPRESENTS OPERATIONAL LIMITS. CROSS-HATCHED AREA IS A ZONE WHERE TAKEOFF IS NOT PERMISSIBLE DUE TO POSSIBLE PITCH-UP AT RAPID RELEASE OF BRAKES WITH ALL ENGINES AT FULL THRUST.

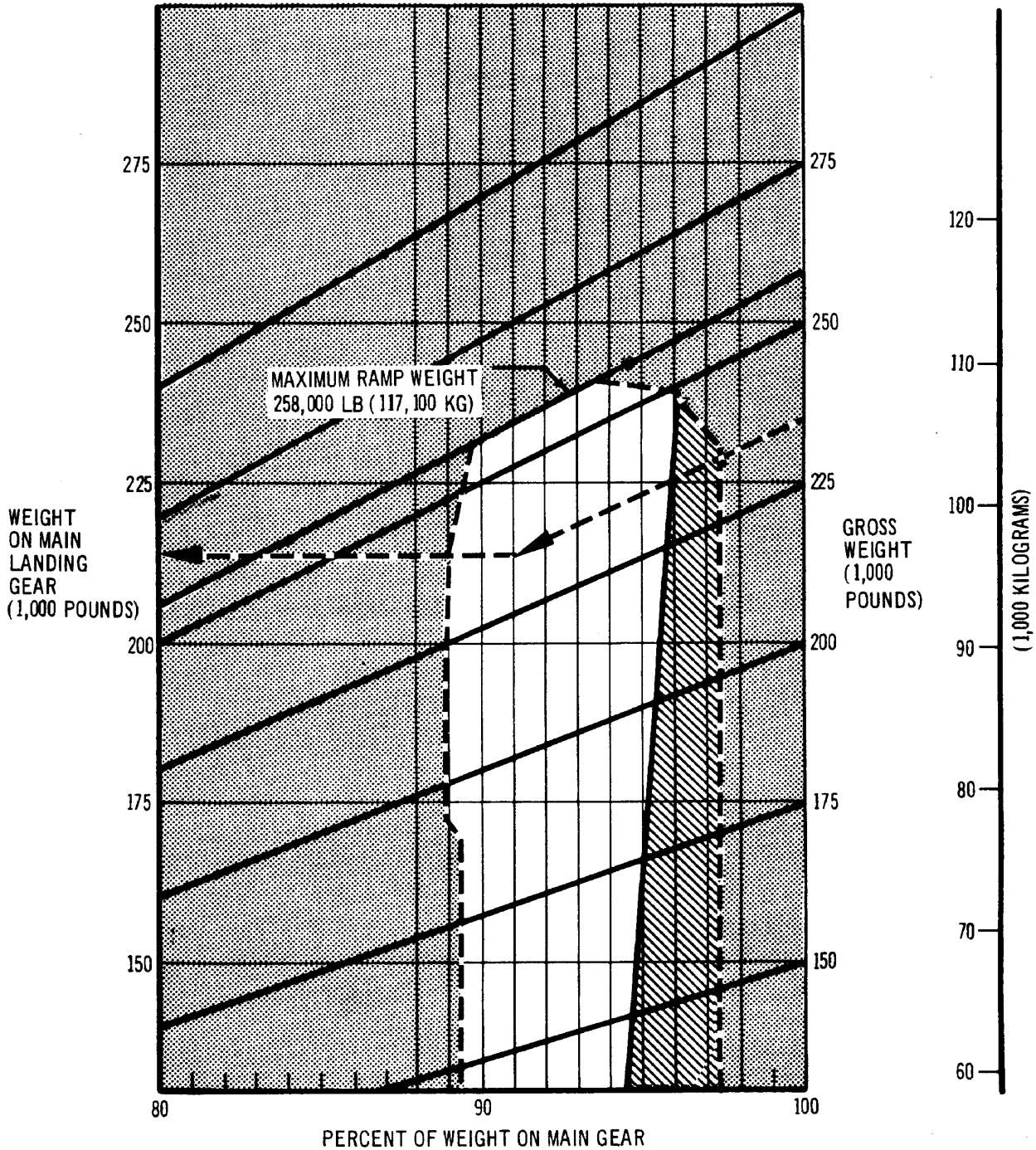

7.4 LANDING GEAR LOADING ON PAVEMENT
MODEL 707-120B

NOTE: UNSHADED AREAS REPRESENT OPERATIONAL LIMITS

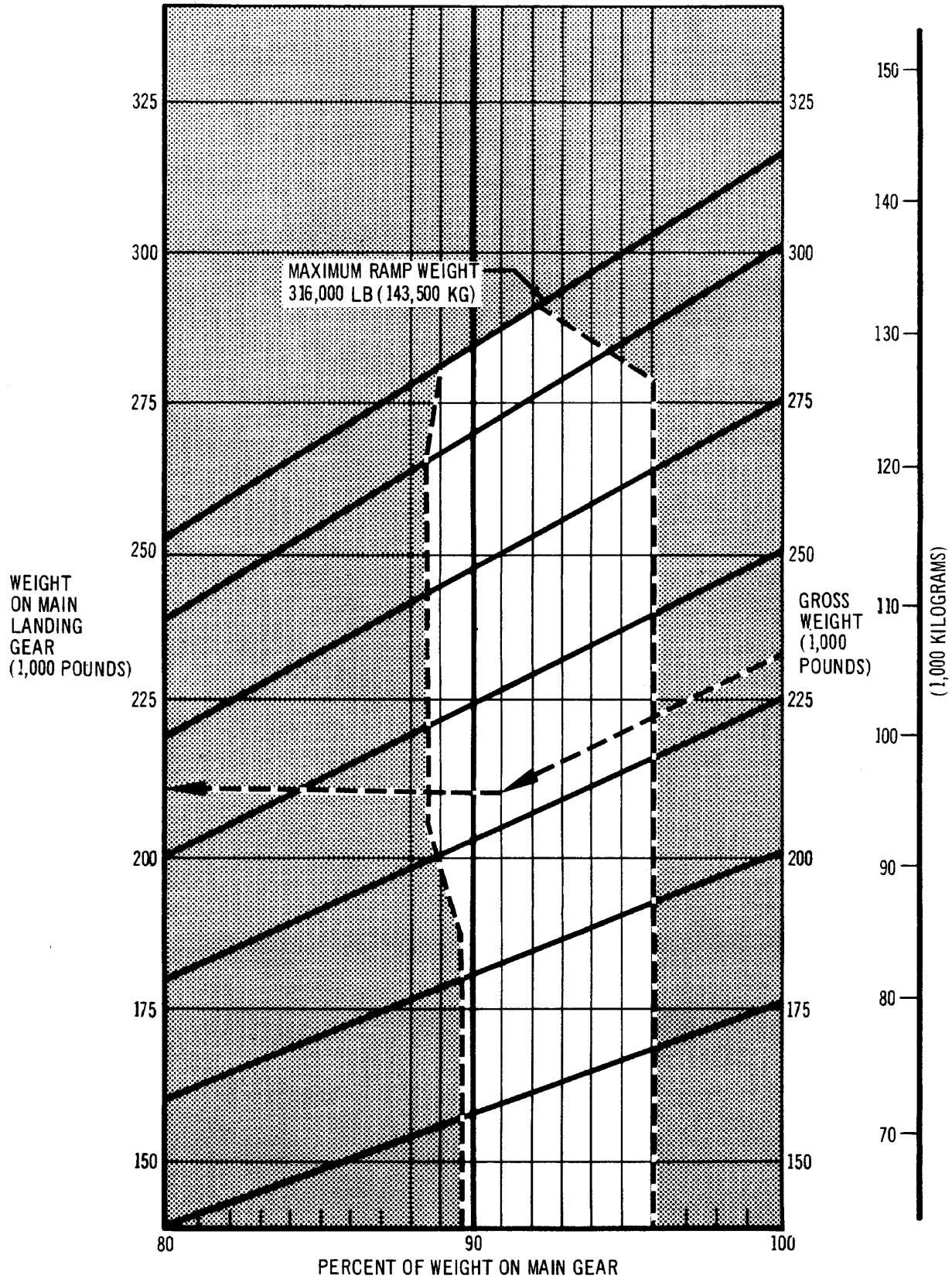

LANDING GEAR LOADING ON PAVEMENT
MODELS 707-320, -420

D6-58322

NOTE: UNSHADED AREAS REPRESENT OPTIONAL LIMITS

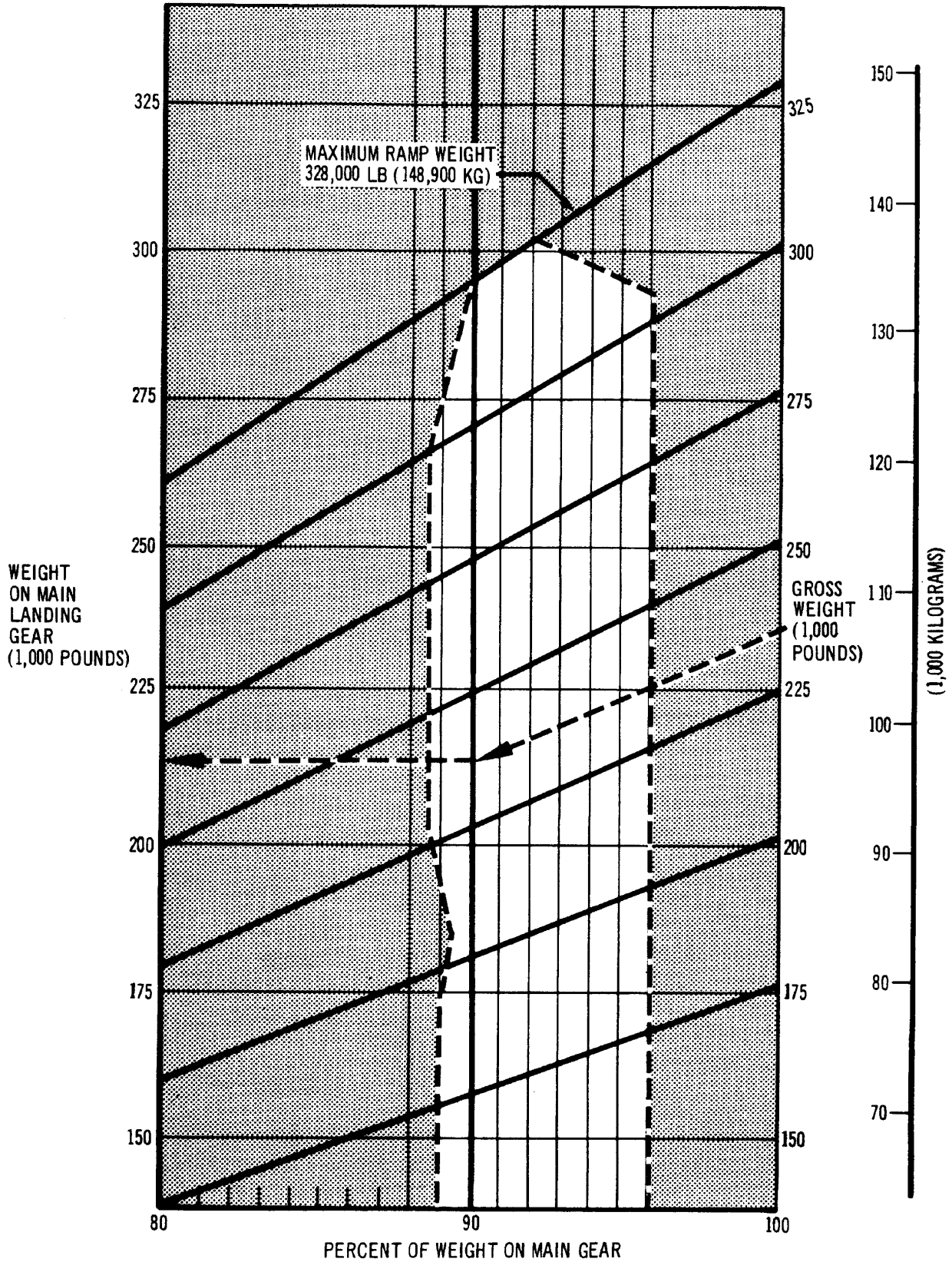

LANDING GEAR LOADING ON PAVEMENT
MODEL 707-320B

NOTE: UNSHADED AREAS REPRESENT OPERATIONAL LIMITS

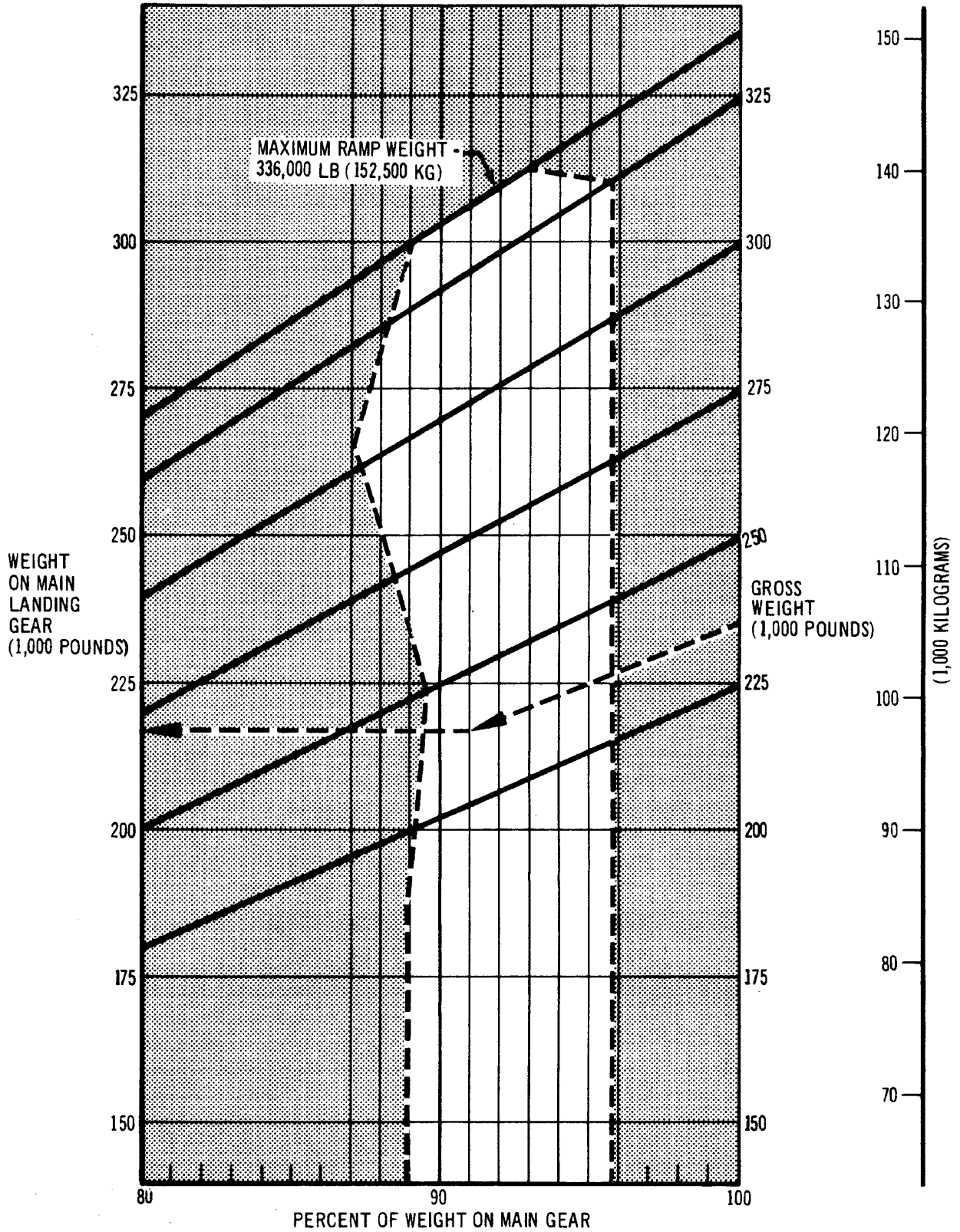

LANDING GEAR LOADING ON PAVEMENT
MODEL 707-320C

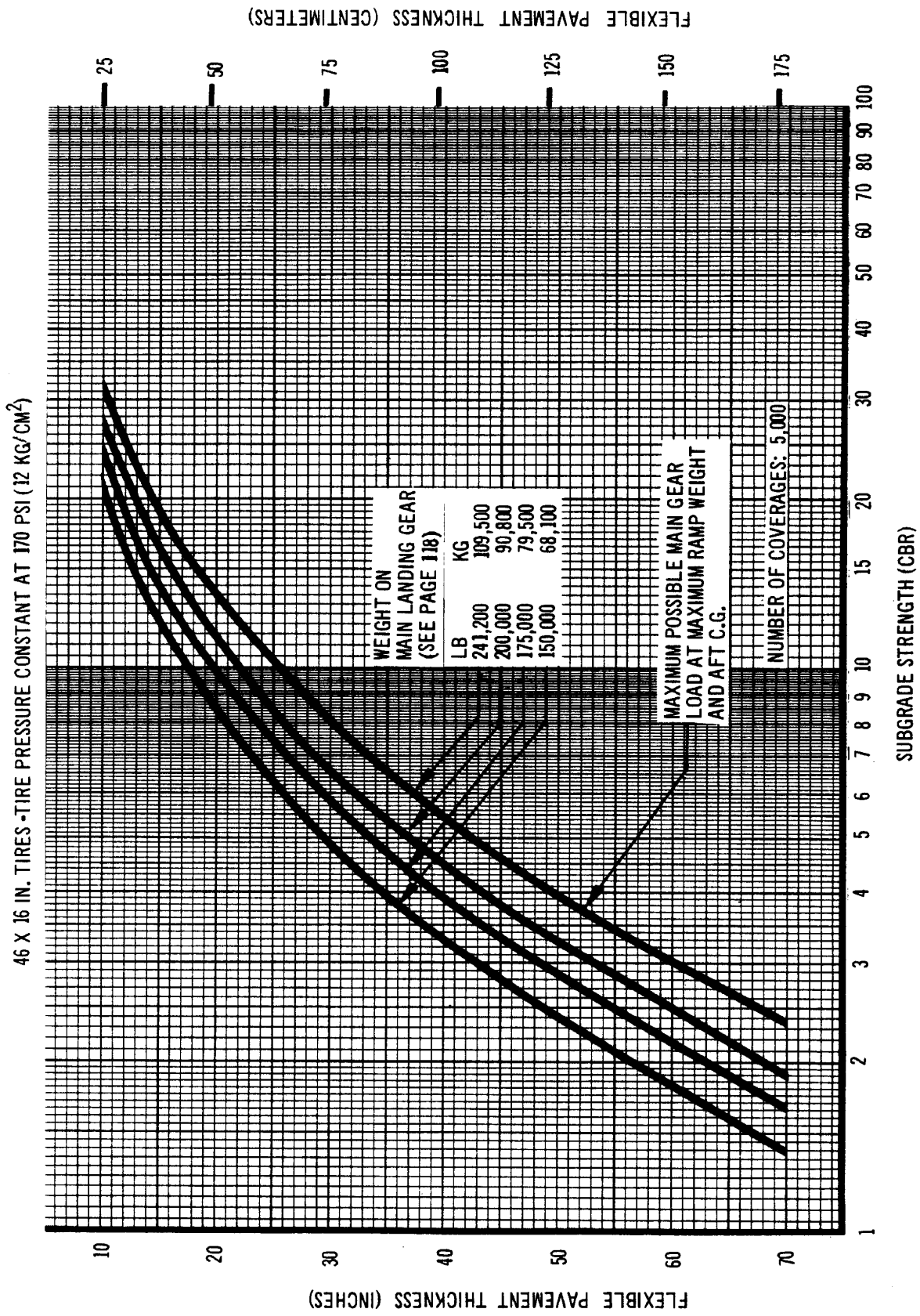

**7.5 FLEXIBLE PAVEMENT REQUIREMENTS - U.S. CORPS OF ENGINEERS
DESIGN METHOD (REF. SEFL 165 A)
MODEL 707-120B**

46 X 16 IN. TIRES - TIRE PRESSURE CONSTANT AT 180 PSI (12.7 kg/cm²)

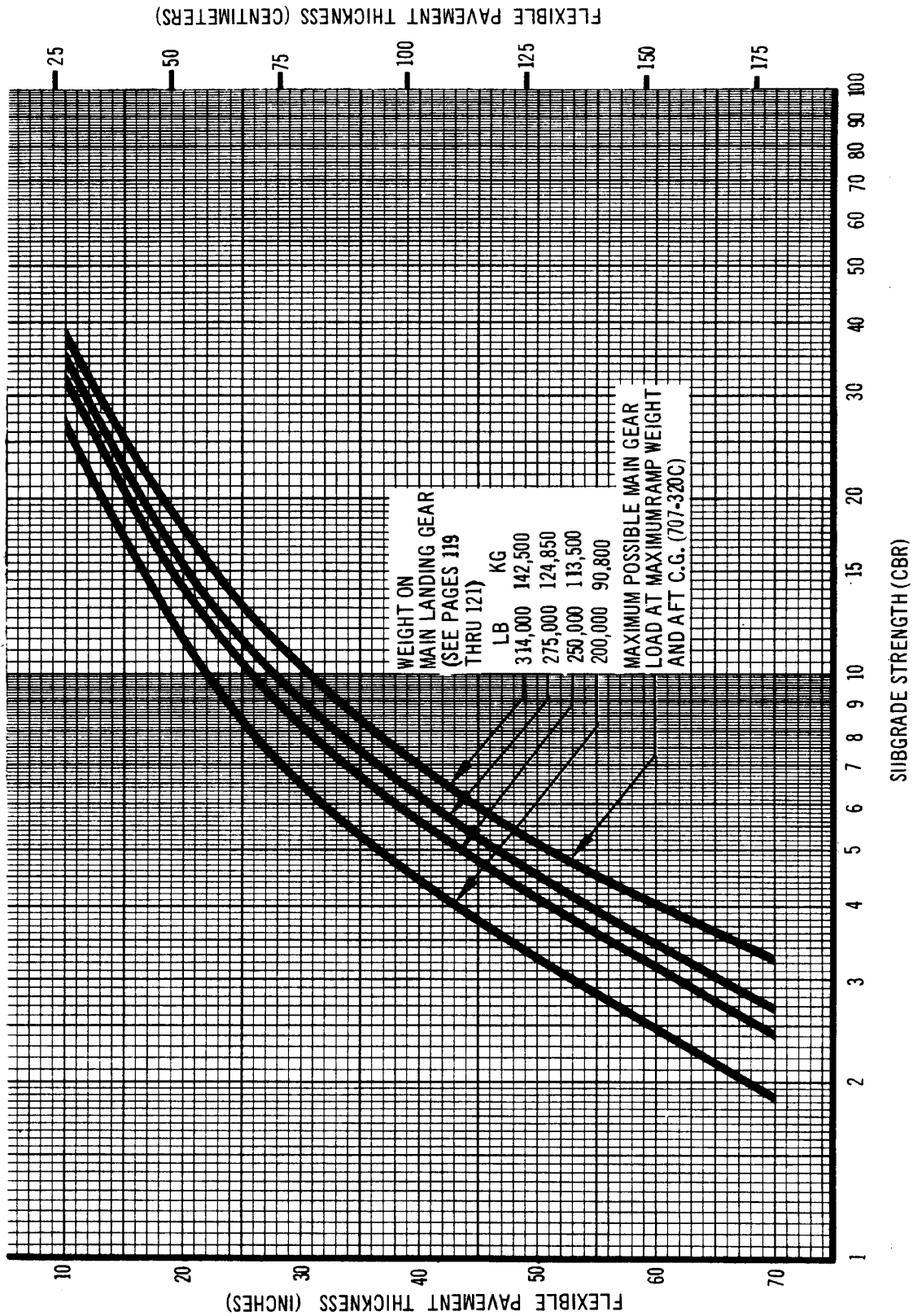

FLEXIBLE PAVEMENT REQUIREMENTS - U.S. CORPS OF ENGINEERS
 DESIGN METHOD (REF. SEFL 165A)
 MODELS 707-320, -320B, -320C, -420

D6-58322

7.6 FLEXIBLE PAVEMENT REQUIREMENTS — LCN CONVERSION

In order to determine the aircraft weight that can be accommodated on a particular flexible pavement, both the LCN of the pavement and the thickness (h) of the pavement must be known.

In the example for the 707-320B shown on page 126, the flexible pavement thickness is shown at 23.6 inches with an LCN of 72. For these conditions the apparent maximum allowable weight permissible on the main landing gear is 250,000 pounds.

NOTE: Provided that the resultant aircraft LCN is not more than 10 percent above the published pavement LCN, the United Kingdom considers the bearing strength of the pavement to be sufficient for unlimited use by the aircraft. The figure of 10 percent has been chosen as representing the lowest degree of variation in LCN that is significant. (Reference: ICAO Aerodrome Manual, Part 2, Aerodrome Physical Characteristics, Chapter 4, Paragraph 4.1.5.7v.)

46 X 16 IN. TIRES - TIRE PRESSURE CONSTANT AT 170 PSI (12 KG/CM²)

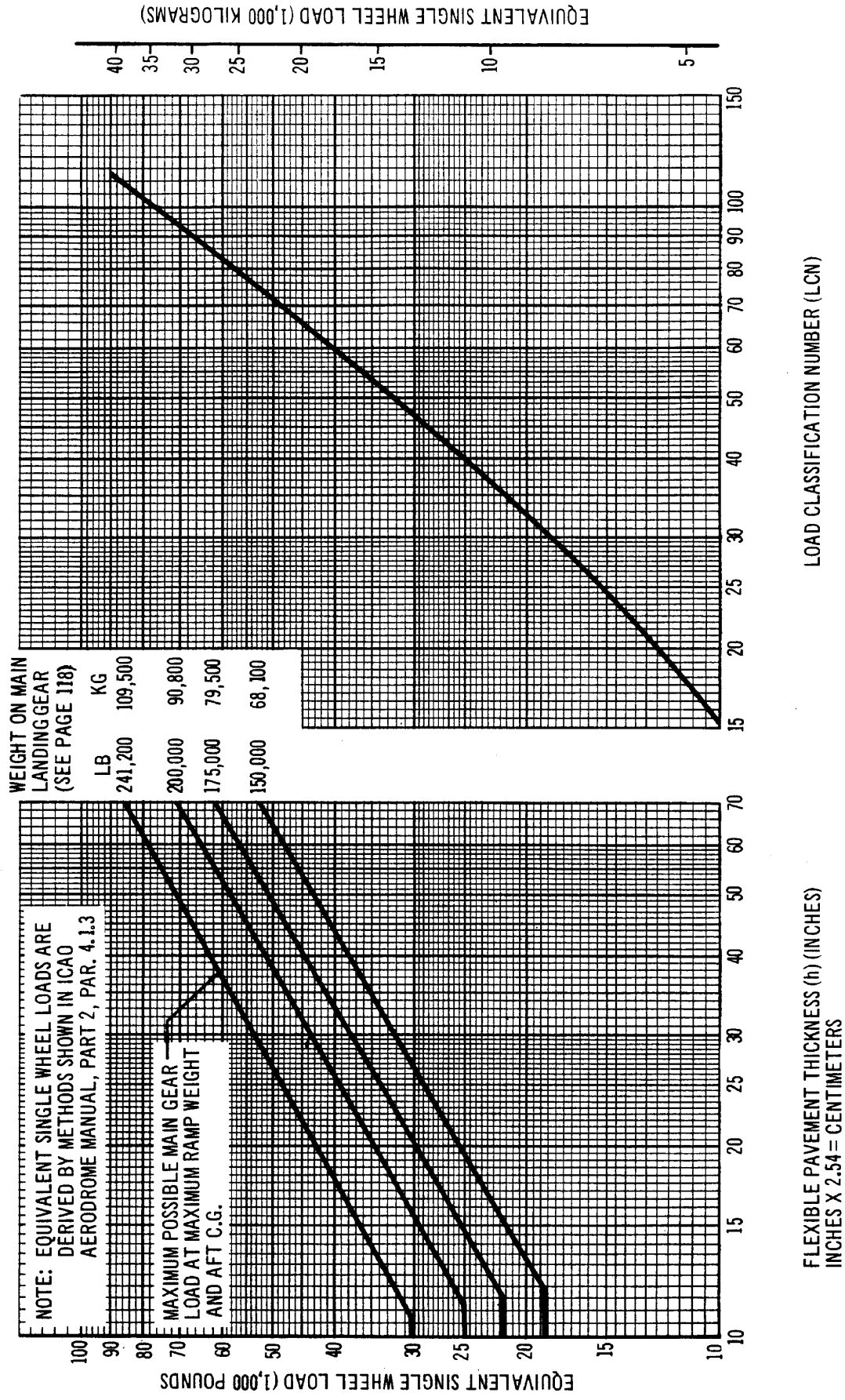

7.6 FLEXIBLE PAVEMENT REQUIREMENTS - LCN CONVERSION MODEL 707-120B

46 X 16 IN. TIRES - TIRE PRESSURE CONSTANT AT 180 PSI (12.7 KG/CM²)

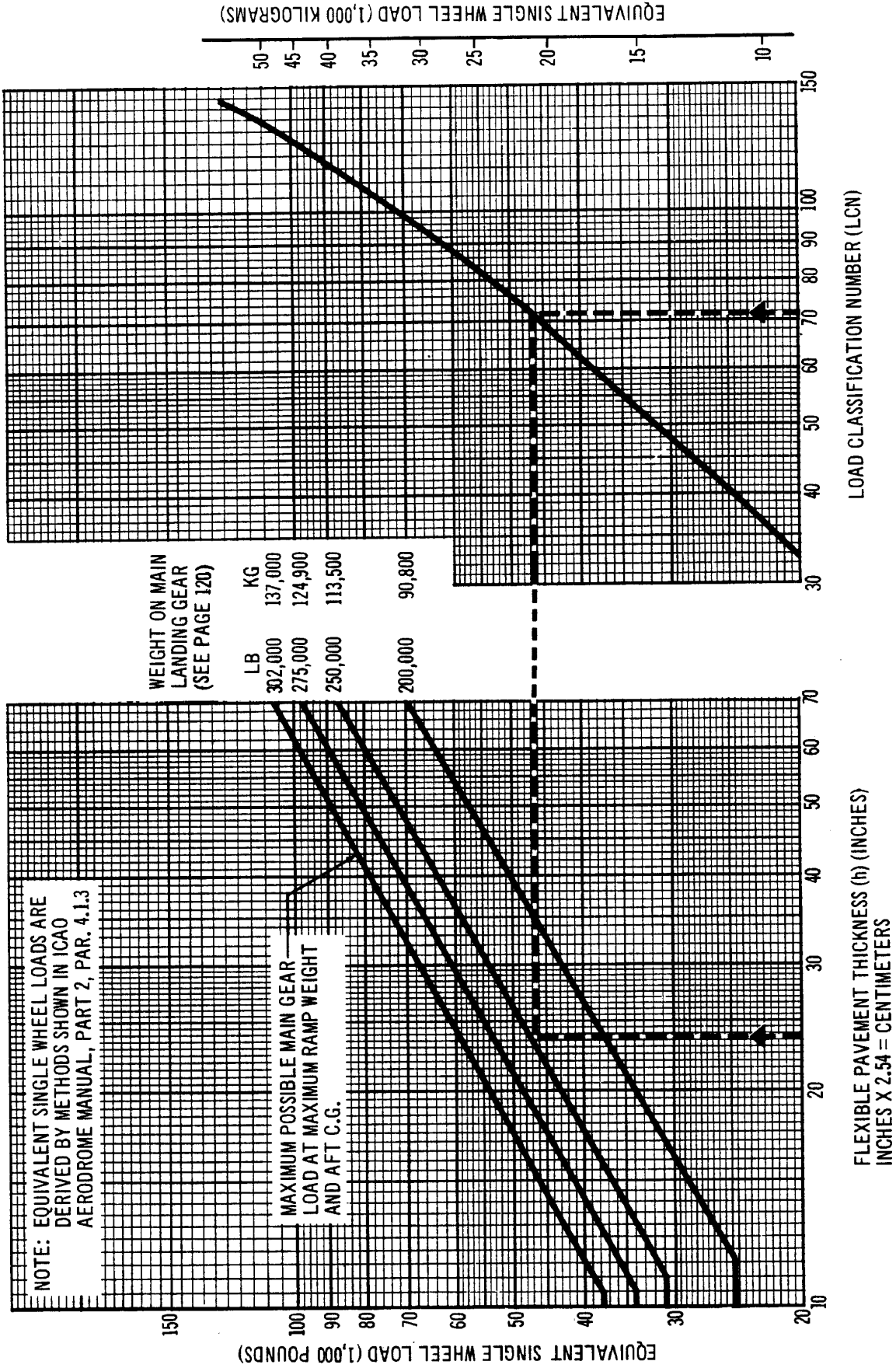

**FLEXIBLE PAVEMENT REQUIREMENTS - LCN CONVERSION
MODEL 707-320B**

46 BY 16 IN. TIRES - TIRE PRESSURE CONSTANT AT 180 PSI (12.7 KG/CM²)

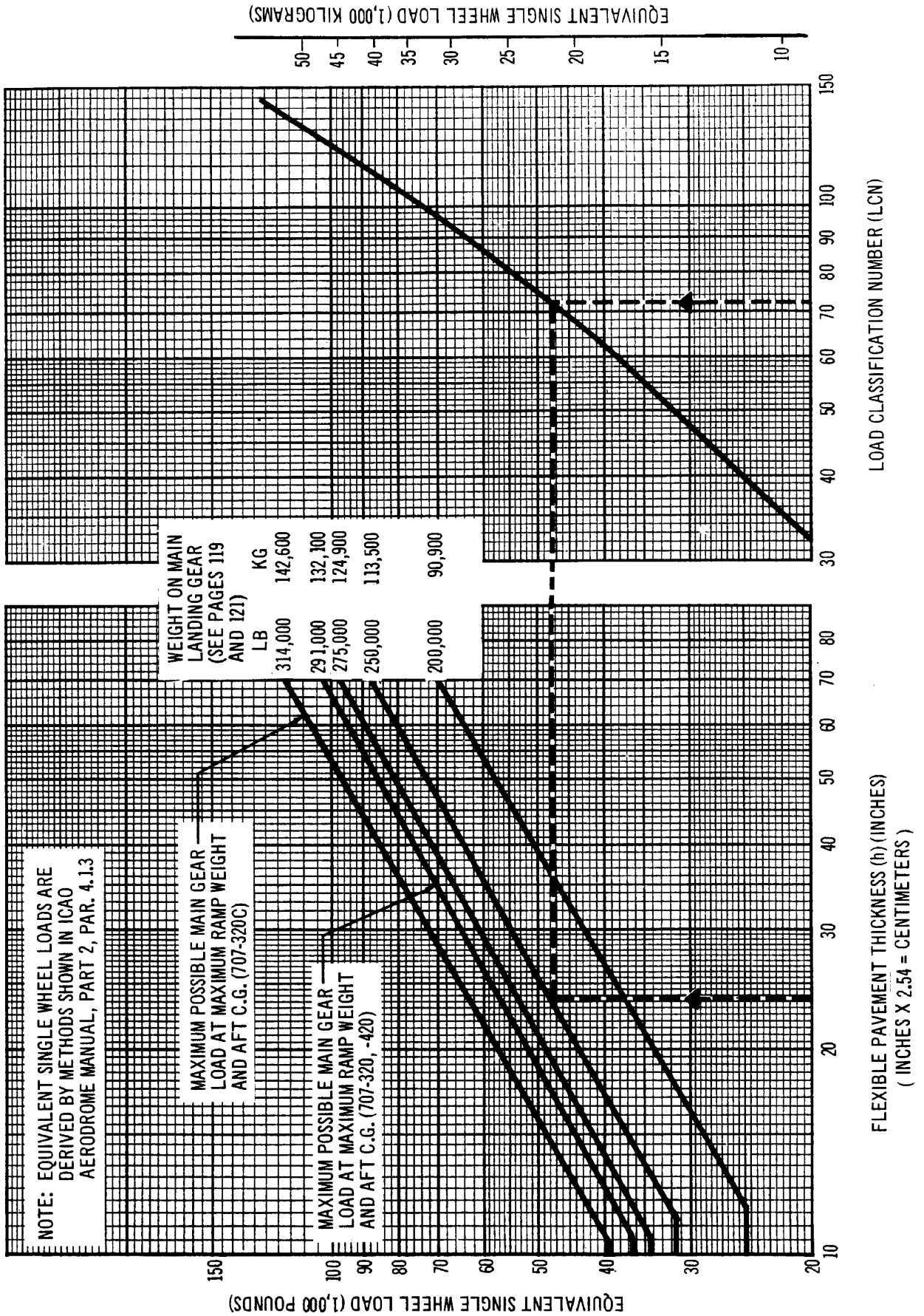

FLEXIBLE PAVEMENT REQUIREMENTS - LCN CONVERSION
MODELS 707-320, -320C, -420

7.7 RIGID PAVEMENT REQUIREMENTS — PORTLAND CEMENT ASSOCIATION DESIGN METHOD

Rigid pavement requirements, herein presented, are based upon two Portland Cement Association practices:

1. The former, standard manual method of counting unit moment blocks on the Pickett and Ray influence charts (Reference: Portland Cement Association publication "The Design of Concrete Airport Pavement" dated 1955)
2. The new computerized version of the above as described in document XP-6705 "Computer Program for Airport Pavement Design" by Robert G. Packard, Portland Cement Association, 1967

Higher stresses for equivalent pavement thicknesses are obtained by the computerized method. These occur because of the following:

1. Increased Radius of Influence

The effect of influence from adjacent wheels by the manual method was limited to approximately 2 times l (the radius of relative stiffness). The computer utilizes the Westergaard equation directly and includes influence from all wheels within a radius of 3 times l .

2. Maximizing Process

It has been common practice when using the manual count method to align the landing gear footprint on the major axis of the influence chart with one wheel centered over the origin. While this practice does not necessarily produce the maximum possible moment, the values obtained have been considered practical since the procedure eliminates arduous repetitive manual summations of moment blocks.

The computer determines the actual maximum stress values by a combination of shifting the footprint in relationship to the origin and by angular rotation of the footprint.

3. Difference in Footprint Shape

An elliptical contact area is used in the computerized version to represent

a single-wheel footprint instead of a rectangle with rounded ends. The variance in moment attributed to this change is minor.

Actual pavement stress for any given model of airplane has not increased. The state of the art in calculation of pavement stress has advanced to permit prediction of stress values to a higher degree of certainty. This permits a proportionate decrease in design stress safety factor.

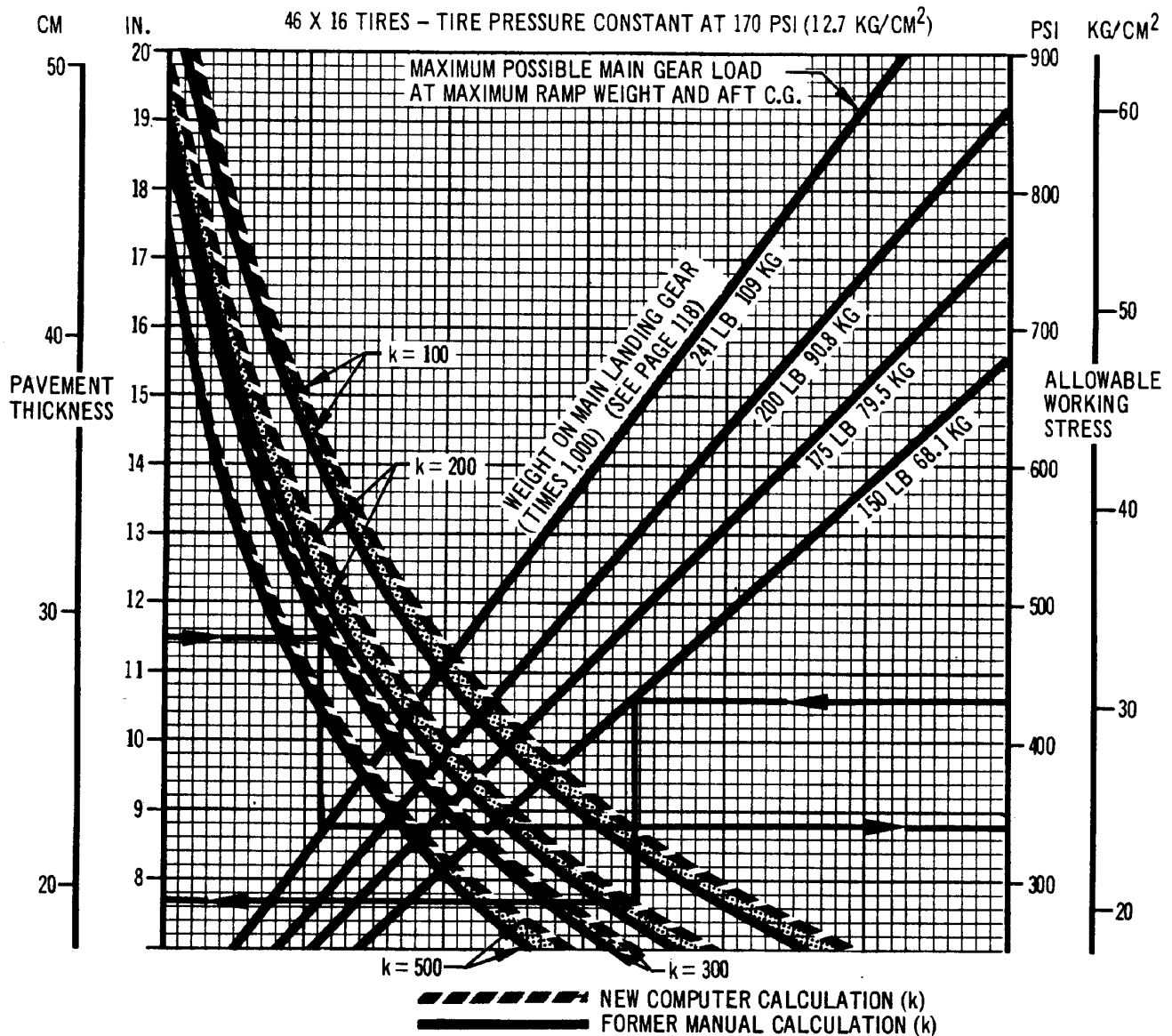

NOTE: THE VALUES OBTAINED BY USING THE MAXIMUM LOAD REFERENCE LINE AND ANY VALUE OF k ARE EXACT. FOR LOADS LESS THAN MAXIMUM, THE CURVES ARE EXACT FOR k = 300 BUT DEVIATE SLIGHTLY FOR OTHER VALUES OF k.

REFERENCES: "DESIGN OF CONCRETE AIRPORT PAVEMENT" AND "COMPUTER PROGRAM FOR AIRPORT PAVEMENT DESIGN" (PROGRAM PDILB) PORTLAND CEMENT ASSN.

NOTICE: DUE TO CHANGES PER NEW COMPUTER METHOD, VALUES OF STRESS ARE HIGHER THAN OBTAINED BY STANDARD MANUAL METHOD. (SEE PAGE 128)

**RIGID PAVEMENT REQUIREMENTS
 PORTLAND CEMENT ASSOCIATION DESIGN METHOD
 MODEL 707-120B**

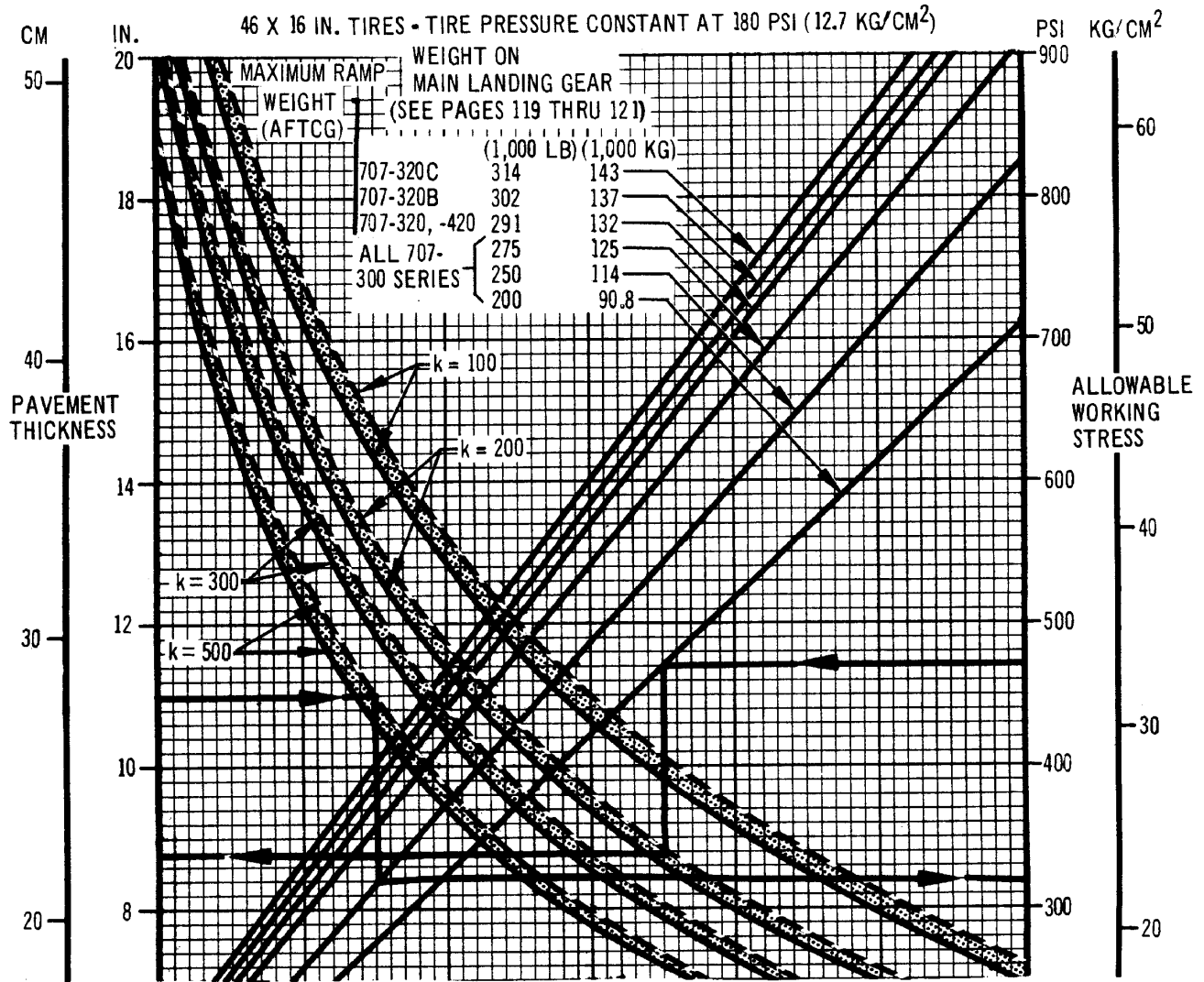

----- NEW COMPUTER CALCULATION (k)
 _____ FORMER MANUAL CALCULATION (k)

NOTES: THE VALUES OBTAINED BY USING THE MAXIMUM LOAD REFERENCE LINE AND ANY VALUE OF k ARE EXACT. FOR LOADS LESS THAN MAXIMUM, THE CURVES ARE EXACT FOR k = 300 BUT DEVIATE SLIGHTLY FOR OTHER VALUES OF k.

REFERENCES: "DESIGN OF CONCRETE AIRPORT PAVEMENT" AND "COMPUTER PROGRAM FOR AIRPORT PAVEMENT DESIGN" (PROGRAM PDILB)
 PORTLAND CEMENT ASSN

NOTICE: DUE TO CHANGES PER NEW COMPUTER METHOD, VALUES OF STRESS ARE HIGHER THAN OBTAINED BY FORMER STANDARD MANUAL METHOD. (SEE PAGE 125)

**RIGID PAVEMENT REQUIREMENTS -
 PORTLAND CEMENT ASSOCIATION DESIGN METHOD
 MODELS 707-320, -320B, -320C, -420**

D6-58322

RADIUS OF RELATIVE STIFFNESS (ℓ)

VALUES OF ℓ IN INCHES

FOR E=4,000,000 P.S.I. AND $\mu = 0.15$

$$\text{RADIUS OF RELATIVE STIFFNESS} = \ell = \sqrt[4]{\frac{E d^3}{12(1-\nu^2)k}} = 24.1652 \sqrt[4]{\frac{d^3}{k}}$$

d IN IN.	k=50	k=100	k=150	k=200	k=250	k=300	k=350	k=400	k=500
6	34.84	29.30	26.47	24.63	23.30	22.26	21.42	20.72	19.59
6.5	36.99	31.11	28.11	26.16	24.74	23.64	22.74	22.00	20.80
7	39.11	32.89	29.72	27.65	26.15	24.99	24.04	23.25	21.99
7.5	41.19	34.63	31.29	29.12	27.54	26.32	25.32	24.49	23.16
8	43.23	36.35	32.85	30.57	28.91	27.62	26.58	25.70	24.31
8.5	45.24	38.04	34.37	31.99	30.25	28.91	27.81	26.90	25.44
9	47.22	39.71	35.88	33.39	31.58	30.17	29.03	28.08	26.55
9.5	49.17	41.35	37.36	34.77	32.89	31.42	30.23	29.24	27.65
10	51.10	42.97	38.83	36.14	34.17	32.65	31.42	30.39	28.74
10.5	53.01	44.57	40.28	37.48	35.45	33.87	32.59	31.52	29.81
11	54.89	46.16	41.71	38.81	36.71	35.07	33.75	32.64	30.87
11.5	56.75	47.72	43.12	40.13	37.95	36.26	34.89	33.74	31.91
12	58.59	49.27	44.52	41.43	39.18	37.44	36.02	34.84	32.95
12.5	60.41	50.80	45.90	42.72	40.40	38.60	37.14	35.92	33.97
13	62.22	52.32	47.27	43.99	41.61	39.75	38.25	36.99	34.99
13.5	64.00	53.82	48.63	45.26	42.80	40.89	39.35	38.06	35.99
14	65.77	55.31	49.98	46.51	43.98	42.02	40.44	39.11	36.99
14.5	67.53	56.78	51.31	47.75	45.16	43.15	41.51	40.15	37.97
15	69.27	58.25	52.63	48.98	46.32	44.26	42.58	41.19	38.95
15.5	70.99	59.70	53.94	50.20	47.47	45.36	43.64	42.21	39.92
16	72.70	61.13	55.24	51.41	48.62	46.45	44.70	43.23	40.88
16.5	74.40	62.56	56.53	52.61	49.75	47.54	45.74	44.24	41.84
17	76.08	63.98	57.81	53.80	50.88	48.61	46.77	45.24	42.78
17.5	77.75	65.38	59.48	54.98	52.00	49.68	47.80	46.23	43.72
18	79.41	66.78	60.35	56.16	53.11	50.74	48.82	47.22	44.66
19	82.70	69.54	62.84	58.48	55.31	52.84	50.84	49.17	46.51
20	85.95	72.27	65.30	60.77	57.47	54.92	52.84	51.10	48.33
21	89.15	74.97	67.74	63.04	59.62	56.96	54.81	53.01	50.13
22	92.31	77.63	70.14	65.28	61.73	58.98	56.75	54.89	51.91
23	95.44	80.26	72.52	67.49	63.83	60.98	58.68	56.75	53.67
24	98.54	82.86	74.87	69.68	65.90	62.96	60.58	58.59	55.41

RADIUS OF RELATIVE STIFFNESS (REFERENCE:
PORTLAND CEMENT ASSOCIATION)

D6-58322

7.8 RIGID PAVEMENT REQUIREMENTS — LCN CONVERSION

In order to determine the aircraft weight that can be accommodated on a particular rigid pavement, both the LCN of the pavement and the radius of relative stiffness (l) of the pavement must be known.

In the example for the 707-320B shown on page 132, the rigid pavement radius of relative stiffness (l) is shown at 30 with an LCN of 58. For these conditions, the apparent maximum allowable weight permissible on the main landing gear is 250,000 pounds.

NOTE: Provided that the resultant aircraft LCN is not more than 10 percent above the published pavement LCN, the United Kingdom considers the bearing strength of the pavement to be sufficient for unlimited use by the aircraft. The figure of 10 percent has been chosen as representing the lowest degree of variation in LCN that is significant. (Reference: ICAO Aerodrome Manual, Part 2, Aerodrome Physical Characteristics, Chapter 4, Paragraph 4.1.5.7v.)

46 X 16 IN. TIRES - TIRE PRESSURE CONSTANT AT 170 PSI (12 KG/CM²)

NOTE: EQUIVALENT SINGLE WHEEL LOADS ARE DERIVED BY METHODS SHOWN IN ICAO AERODROME MANUAL, PART 2, PAR. 4.1.3

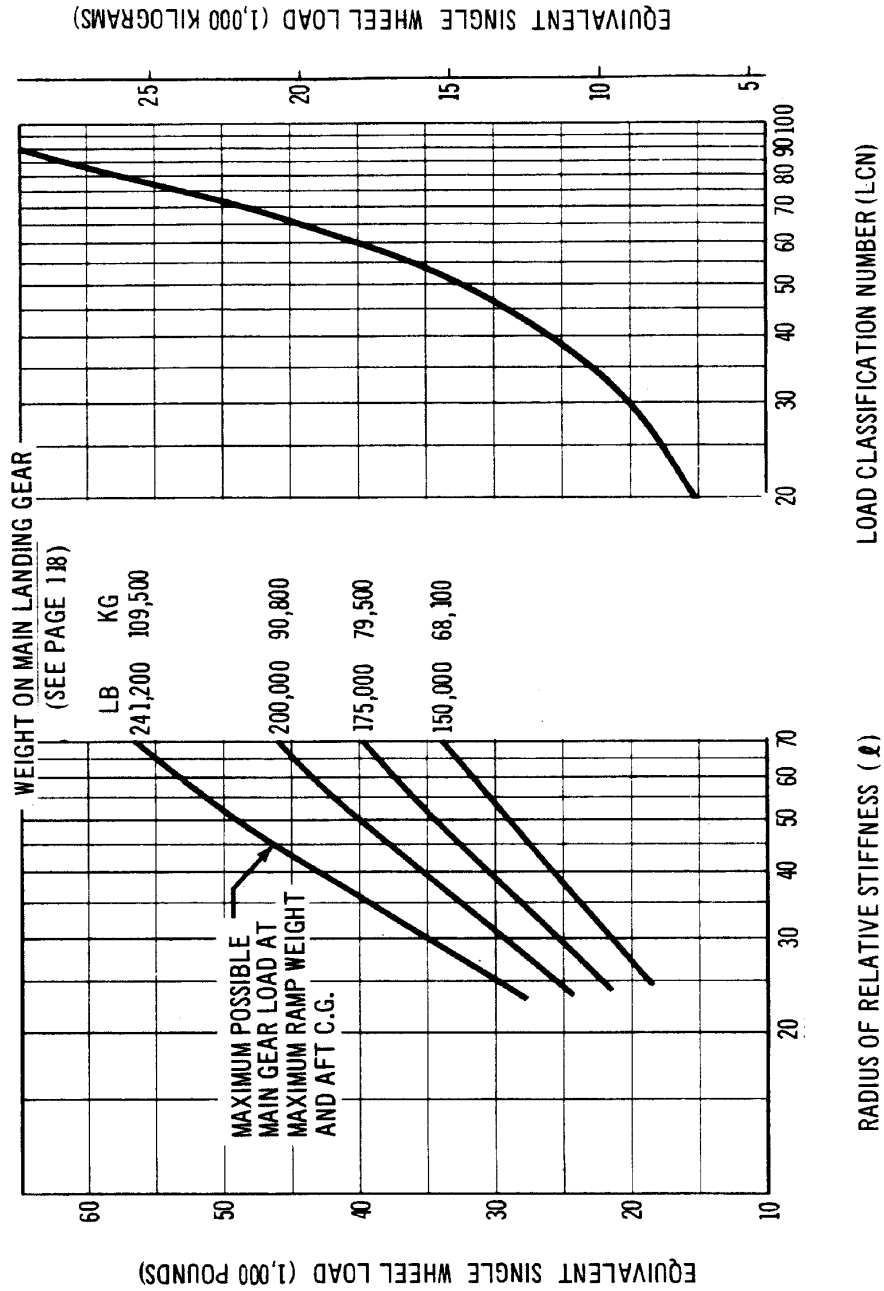

**RIGID PAVEMENT REQUIREMENTS - LCN CONVERSION
MODEL 707-120B**

46 X 16 IN. TIRES - TIRE PRESSURE CONSTANT AT 180 PSI (12.7 KG/CM²)

NOTE: EQUIVALENT SINGLE WHEEL LOADS ARE DERIVED BY METHODS SHOWN IN ICAO AERODROME MANUAL, PART 2, PAR. 4.1.3

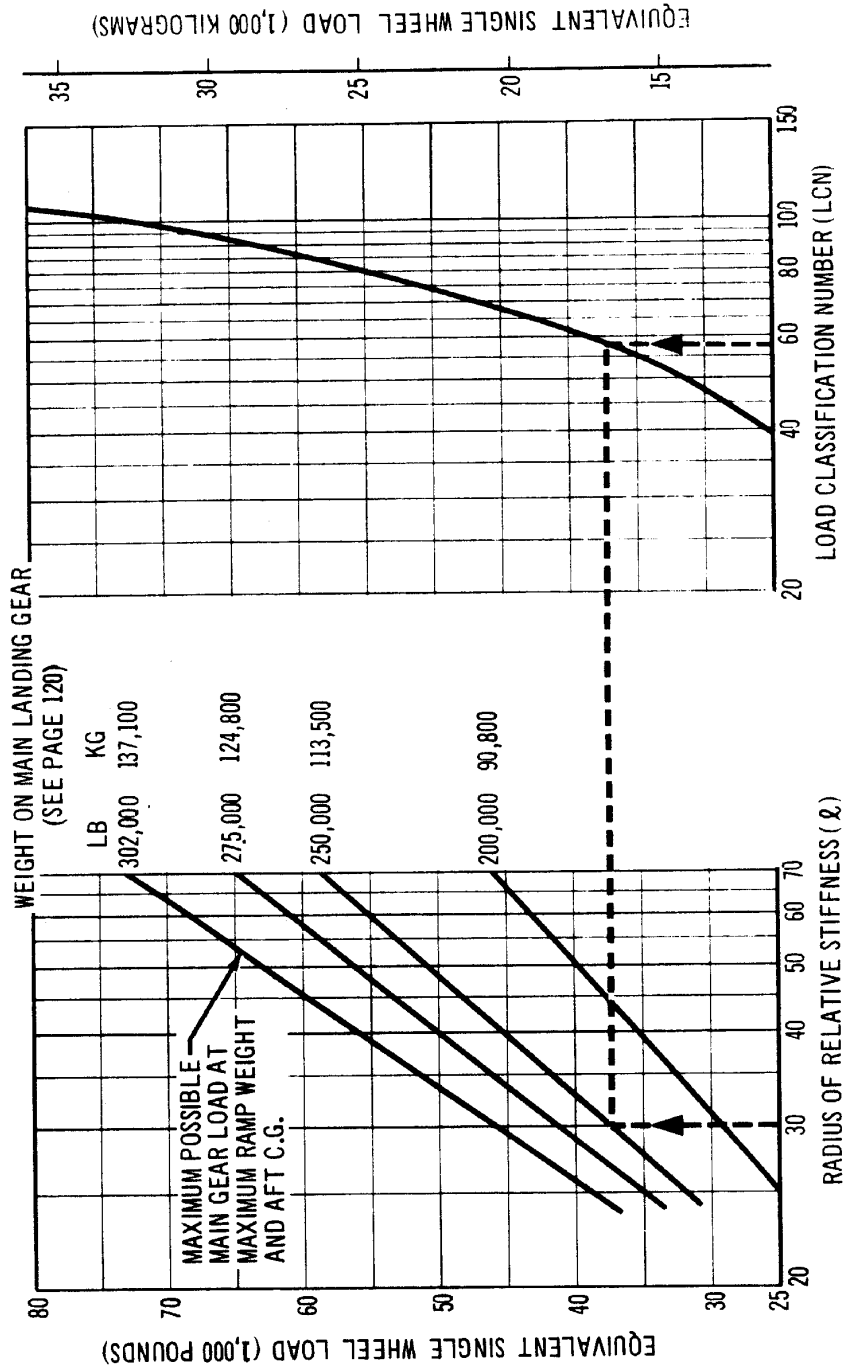

RIGID PAVEMENT REQUIREMENTS - LCN CONVERSION
MODEL 707-320B

46 X 16 IN. TIRES - TIRE PRESSURE CONSTANT AT 180 PSI (12.7 KG/CM²)

NOTE: EQUIVALENT SINGLE WHEEL LOADS ARE DERIVED BY METHODS SHOWN IN ICAO AERODROME MANUAL, PART 2, PAR. 4.1.3

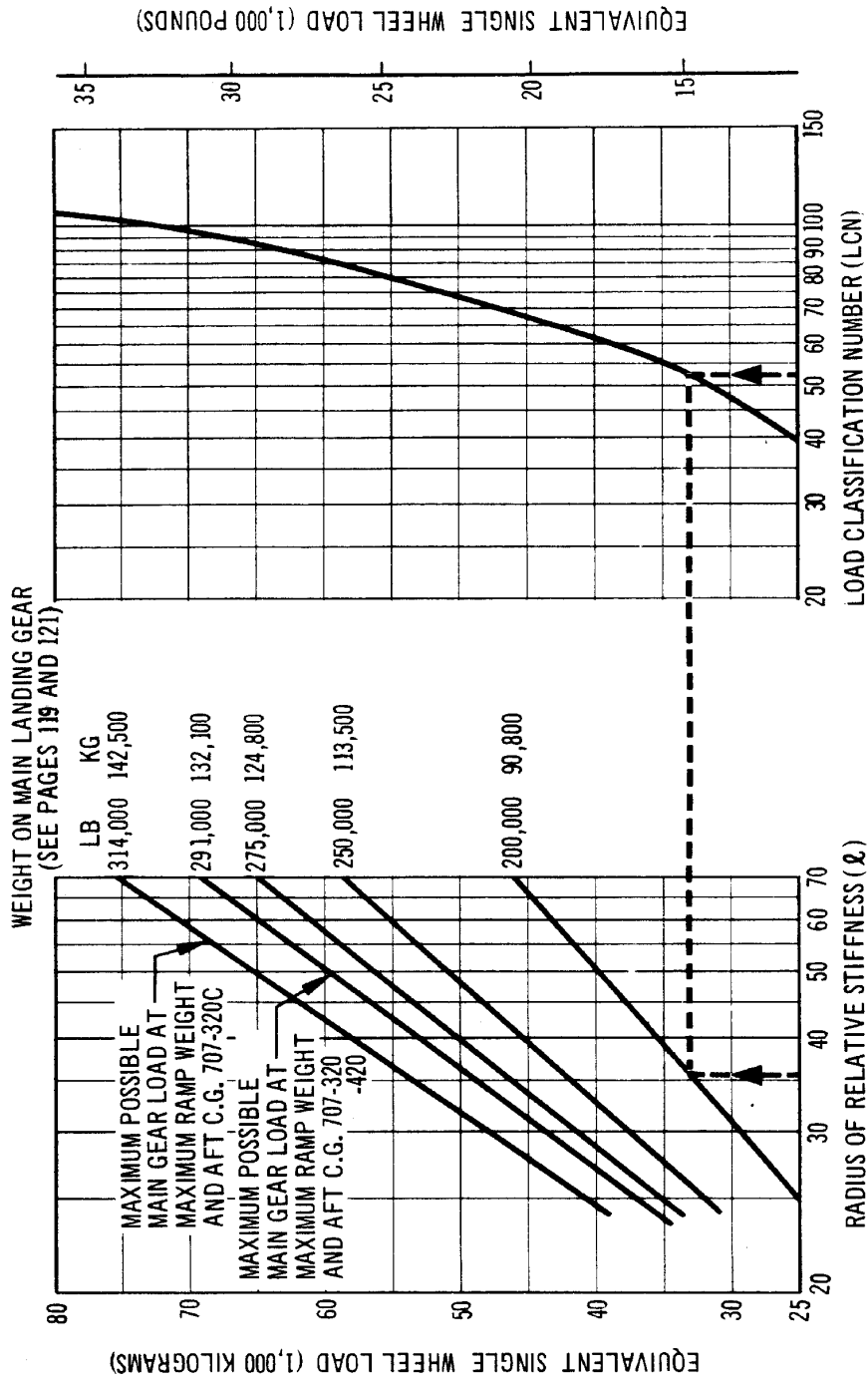

**RIGID PAVEMENT REQUIREMENTS - LCN CONVERSION
MODELS 707-320, -320C, -420**

7.9 FAA METHOD

The charts on pages 138 and 139 are developed directly from pages in FAA Advisory Circular AC 150/5320-6A, dated May 9, 1967.

Pavement thicknesses are shown for gross aircraft weight, irrespective of landing gear configuration and tire pressure. The following general assumptions were made by the FAA in preparing the charts:

1. Ninety five percent of the gross aircraft weight is assumed to be supported by the main gear.
2. Dual-tandem wheel spacings are not given specifically, but certain design compromises are made as described in the Advisory Circular Appendix 1 in order to develop the curves shown.

The subgrade ratings for pavements are shown as standard FAA designations. These ratings and their derivation are fully described in the Advisory Circular mentioned above.

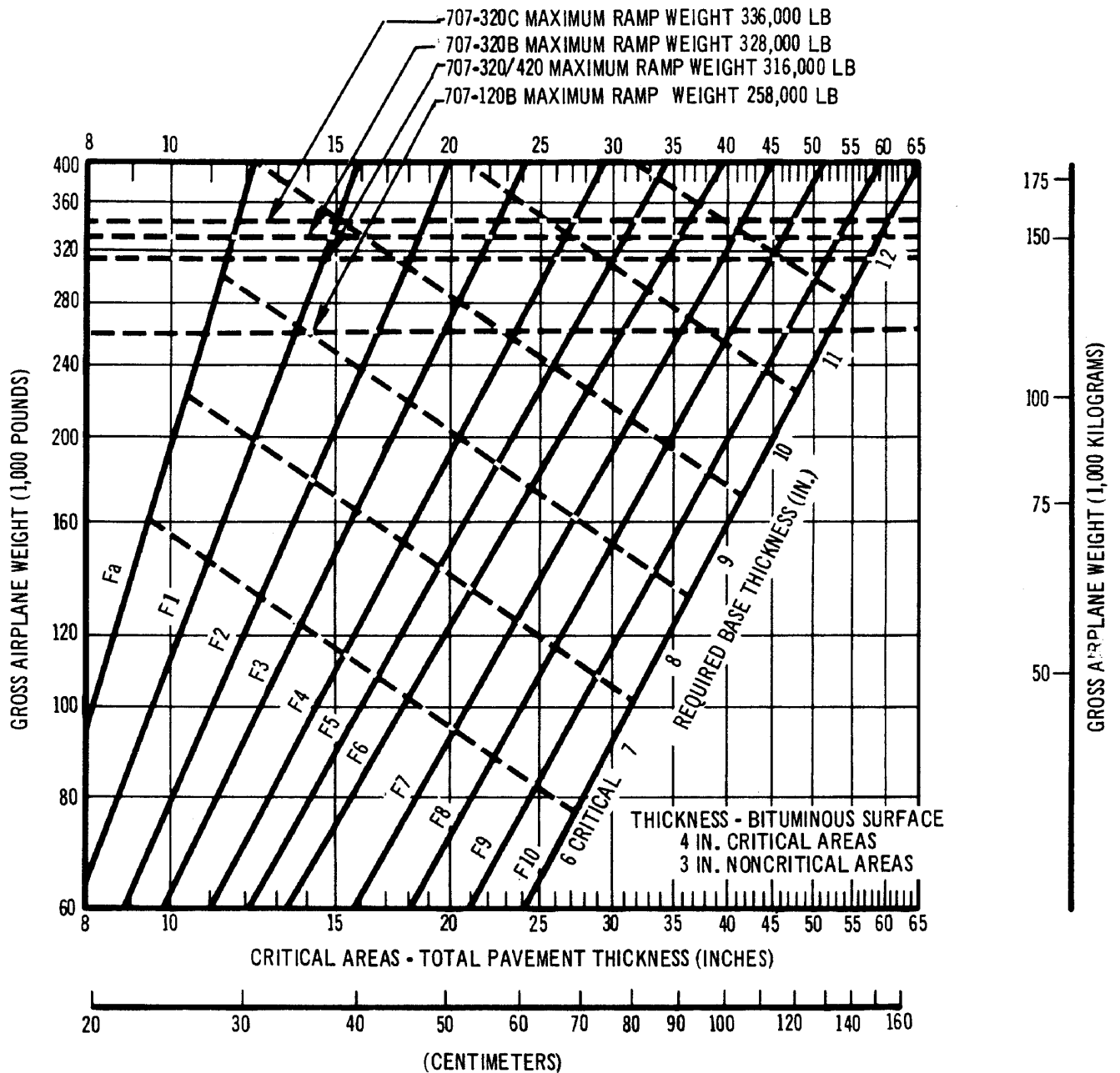

NOTE: ● PAVEMENT SUBGRADE RATINGS (Fa, F1, F2, ETC.) ARE REPRESENTED BY THE DIAGONAL LINES IN THE CHART. INTERSECTION OF A LINE DENOTING SUBGRADE WITH WEIGHT DETERMINES PAVEMENT THICKNESS.

● CHART ADAPTED FROM PAGE 31 (AND 32), PAR. 17 CHAP. 3 OF FAA ADVISORY CIRCULAR AC 150/5320-6A, DATED 9 MAY 1967.

**FLEXIBLE PAVEMENT REQUIREMENTS - FAA METHOD
 MODELS 707-120B, -320, -320B, -320C, -420**

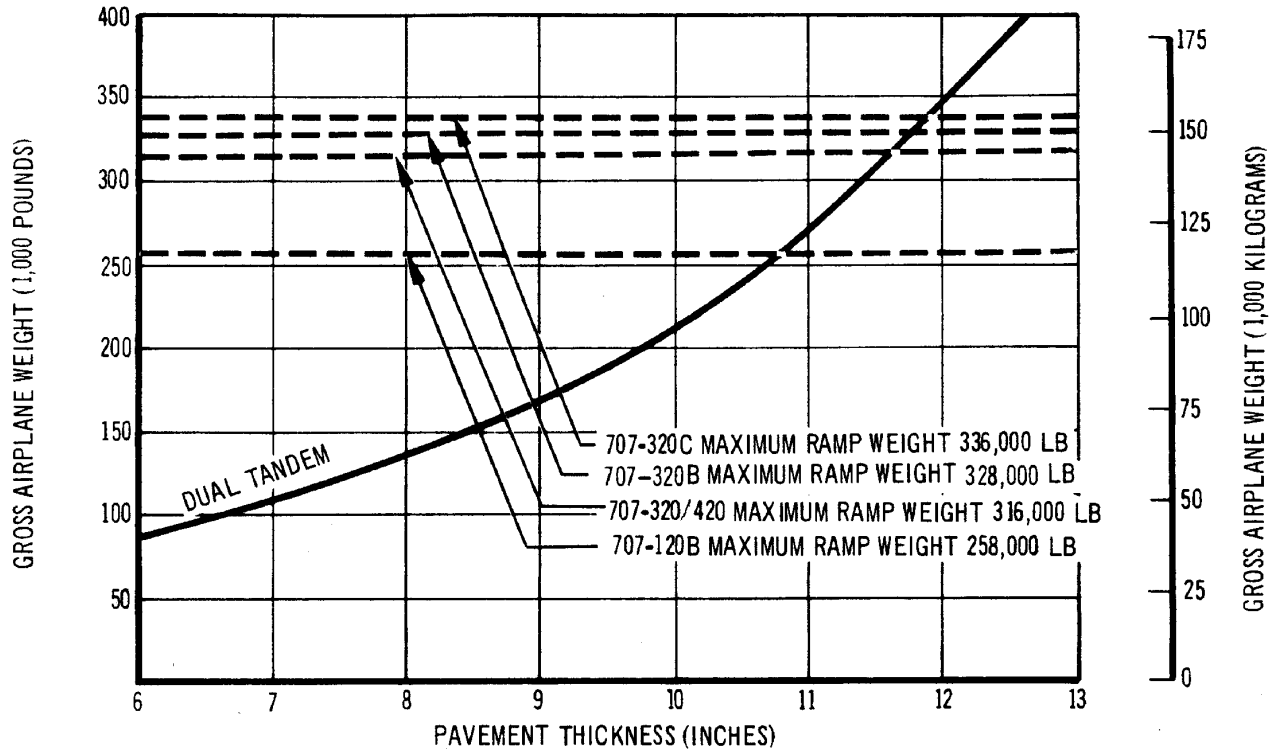

NOTE: Ra, Rb, Rc, Rd, AND Re FAA PAVEMENT SUBGRADE RATINGS

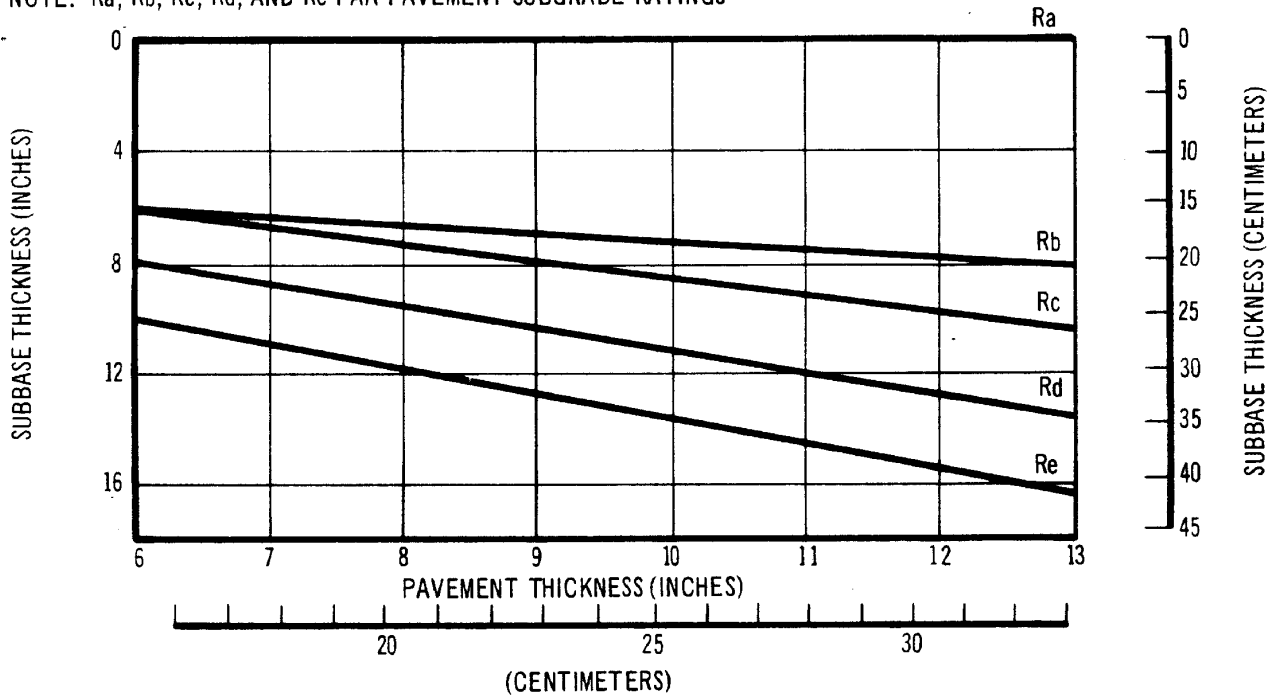

NOTE: CHART ADAPTED FROM PAGE 31 (AND 32),
 PAR. 17 CHAP. 3 OF FAA ADVISORY CIRCULAR
 AC 150/5320-6A, DATED 9 MAY 1967.

PAVEMENT REQUIREMENTS - FAA METHOD
 MODEL 707-120B, -320, -320B, -320C, -420

7.10 ACN/PCN Reporting System - Flexible and Rigid Pavements

To determine the ACN of an aircraft on flexible or rigid pavement, both the aircraft gross weight and the subgrade strength category must be known. In the chart in 7.10.1, for an aircraft with gross weight of 260,000 lb on a (Code B), the flexible pavement ACN is 32. Referring to 7.10.2, the same aircraft on a medium strength subgrade rigid pavement has an ACN of 33.5.

The following table provides ACN data in tabular format similar to the one used by ICAO in the “Aerodrome Design Manual Part 3, Pavements.” If the ACN for an intermediate weight between maximum taxi weight and minimum weight of the aircraft is required, Figures 7.10.1 through 7.10.2 should be consulted.

AIRCRAFT TYPE	MAXIMUM TAXI WEIGHT MINIMUM WEIGHT (1) LB (KG)	LOAD ON ONE MAIN GEAR LEG (%)	TIRE PRESSURE PSI (MPa)	ACN FOR RIGID PAVEMENT SUBGRADES – MN/m ³				ACN FOR FLEXIBLE PAVEMENT SUBGRADES – CBR			
				HIGH 150	MEDIUM 80	LOW 40	ULTRA LOW 20	HIGH 15	MEDIUM 10	LOW 6	ULTRA LOW 3
707-320C	336,000(152,400)	28.50	180 (1.24)	41	46	55	71	41	48	57	66
	155,100(70,400)			16	16	18	24	15	17	20	23

(1) Minimum weight used solely as a baseline for ACN curve generation.

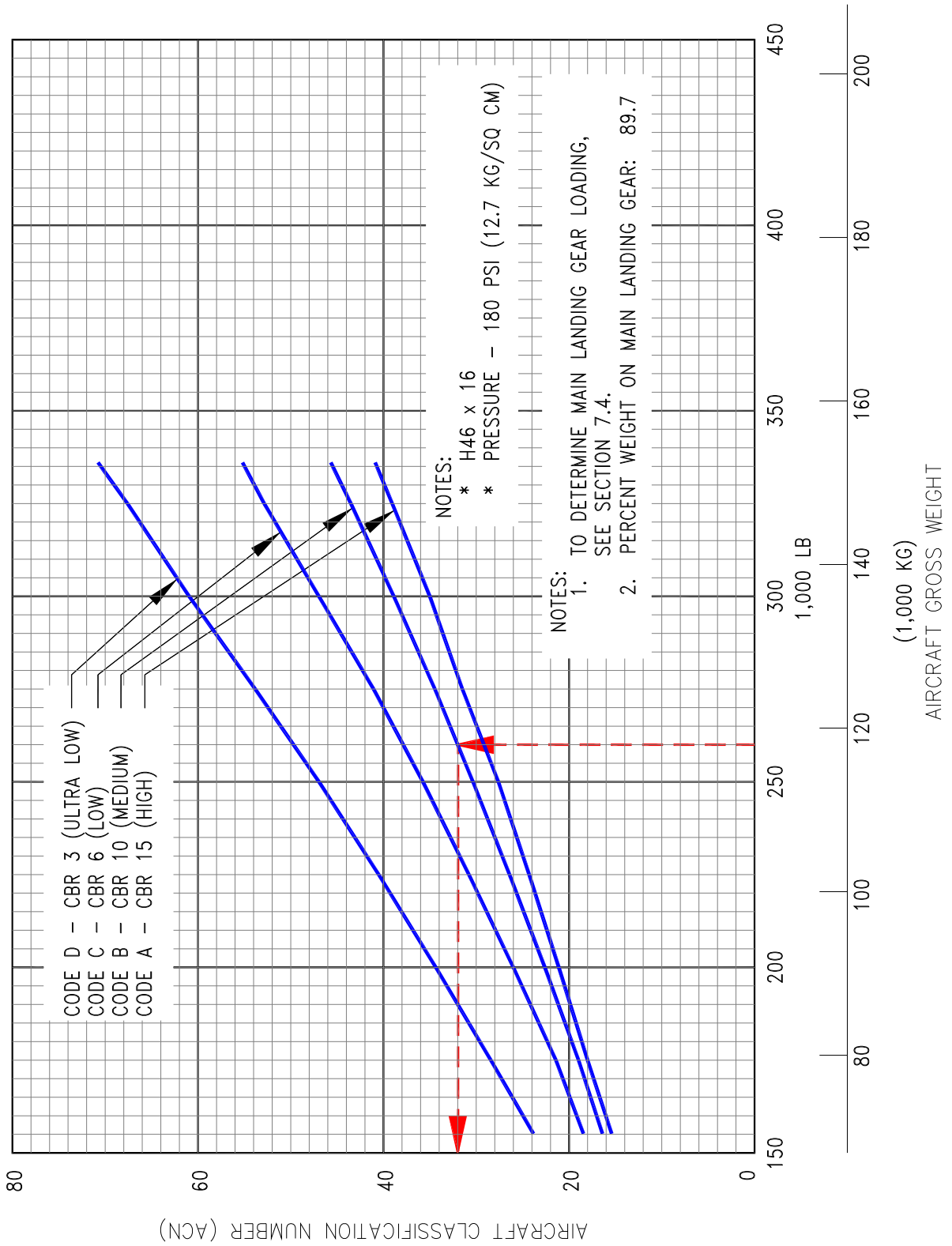

7.10.1 AIRCRAFT CLASSIFICATION NUMBER - FLEXIBLE PAVEMENT
 MODEL 707-320C

D6-58322

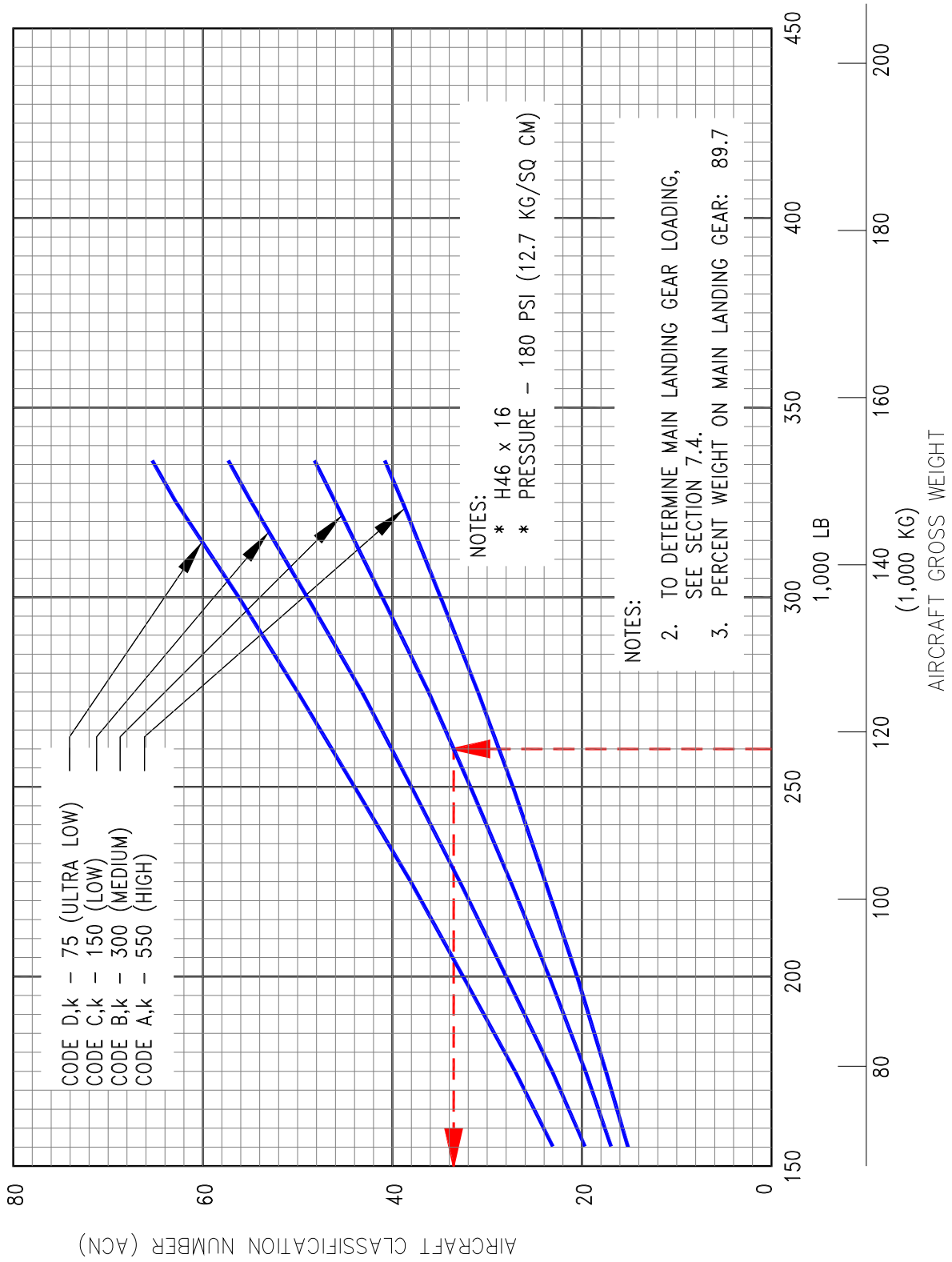

7.10.2 AIRCRAFT CLASSIFICATION NUMBER - RIGID PAVEMENT
 MODEL 707-320C