



717-200

Airplane Characteristics for

Airport Planning



Not Subject to US Export Administration Regulations (EAR), (15 C.F.R. Parts 730-774)
or US International Traffic in Arms Regulations (ITAR), (22 C.F.R. Parts 120-130).

**717-200 AIRPLANE CHARACTERISTICS
LIST OF ACTIVE PAGES**

Rev	Page	Date	Description
New	1 - 95	July 1999	Initial Preliminary version
Rev A	1 to 108	August 2001	Initial Final version
--	3	May 2011	Minor update to contact information only
Rev B	1 - 99	Nov 2014	Added Single Engine Taxi contours to Sect 6; revised contact information; other minor administrative revisions for consistency

TABLE OF CONTENTS

<u>SECTION</u>	<u>TITLE</u>	<u>PAGE</u>
1.0	SCOPE AND INTRODUCTION	1
1.1	Scope	2
1.2	Introduction	3
1.3	A Brief Description of the 717-200	4
2.0	AIRPLANE DESCRIPTION	5
2.1	General Characteristics	6
2.2	General Dimensions	8
2.3	Ground Clearances	9
2.4	Interior Arrangements	10
2.5	Cabin Cross-Sections	12
2.6	Lower Cargo Compartments	14
2.7	Door Clearances	15
3.0	AIRPLANE PERFORMANCE	21
3.1	General Information	22
3.2	Payload/Range for Long-Range Cruise	23
3.3	F.A.R. Takeoff Runway Length Requirements	24
3.4	F.A.R. Landing Runway Length Requirements	32
4.0	GROUND MANEUVERING	33
4.1	General Information	34
4.2	Turning Radii	35
4.3	Clearance Radii	36
4.4	Visibility from Cockpit in Static Position	37
4.5	Runway and Taxiway Turn Paths	38
4.6	Runway Holding Bay	42
5.0	TERMINAL SERVICING	43
5.1	Airplane Servicing Arrangement - Typical	45
5.2	Terminal Operations, Turnaround Station	46
5.3	Terminal Operations, Enroute Station	47
5.4	Ground Servicing Connections	48
5.5	Engine Starting Pneumatic Requirements	50
5.6	Ground Pneumatic Power Air Requirements	51
5.7	Preconditioned Airflow Requirements	53
5.8	Ground Towing Requirements	54

TABLE OF CONTENTS (CONTINUED)

<u>SECTION</u>	<u>TITLE</u>	<u>PAGE</u>
6.0	JET ENGINE WAKE AND NOISE DATA	55
6.1	Jet Engine Exhaust Velocities and Temperatures	56
6.2	Airport and Community Noise	65
7.0	PAVEMENT DATA	68
7.1	General Information	69
7.2	Landing Gear Footprint	72
7.3	Maximum Pavement Loads	73
7.4	Landing Gear Loading on Pavement	74
7.5	Flexible Pavement Requirements - U.S. Army Corps of Engineers Method (S-77-1)	77
7.6	Flexible Pavement Requirements - LCN Method	79
7.7	Rigid Pavement Requirements - Portland Cement Association Design Method	81
7.8	Rigid Pavement Requirements - LCN Conversion	83
7.9	Rigid Pavement Requirements - FAA Method	86
7.10	ACN/PCN Reporting System - Flexible and Rigid Pavements	88
7.11	Tire Inflation Chart	95
8.0	FUTURE 717 DERIVATIVE AIRPLANES	96
9.0	SCALED 717-200 DRAWINGS	98

1.0 SCOPE AND INTRODUCTION

1.1 Scope

1.2 Introduction

1.3 A Brief Description of the 717-200

1.0 SCOPE AND INTRODUCTION

1.1 Scope

This document provides, in a standardized format, airplane characteristics data for general airport planning. Since operational practices vary among airlines, specific data should be coordinated with the using airlines prior to facility design. Boeing Commercial Airplanes should be contacted for any additional information required.

Content of the document reflects the results of a coordinated effort by representatives from the following organizations:

- | Aerospace Industries Association
- | Airports Council International - North America
- | Air Transport Association of America
- | International Air Transport Association

The airport planner may also want to consider the information presented in the "CTOL Transport Aircraft, Characteristics, Trends, and Growth Projections," available from the US AIA, 1250 Eye St., Washington DC 20005, for long-range planning needs. This document is updated periodically and represents the coordinated efforts of the following organizations regarding future aircraft growth trends:

- | International Coordinating Council of Aerospace Industries Associations
- | Airports Council International - North America
- | Air Transport Association of America
- | International Air Transport Association

1.2 Introduction

This document conforms to NAS 3601. It provides characteristics of the Boeing Model 717-200 airplane for airport planners and operators, airlines, architectural and engineering consultant organizations, and other interested industry agencies. Airplane changes and available options may alter model characteristics; the data presented herein reflect typical airplanes in each model category.

For additional technical data or to contact the Boeing Airport Compatibility organization, please see the following webpage:

www.boeing.com/airports

1.3 A Brief Description of the 717-200 Airplane

the 717-200 is a twin-engine aircraft designed for short-haul short-field operations. It can carry 106 passengers in a mixed class configuration up to a range of approximately 2000 miles. It is designed to sustain daily 8 to 12 one-hour flights for fast turnaround at airport gates.

The 717-200 is powered by two advanced BMW/Rolls-Royce BR715 high-bypass-ratio engines. The BR715 engine is rated at 18,500 pounds of takeoff thrust, with lower fuel consumption, reduced exhaust emissions and significantly lower noise levels than the power plants on comparable airplanes. The thrust is uprated to 21,000 pounds for the high-gross-weight option airplanes.

An optional airstair under the main entry door number 1 allows operation at airports where there are no loading bridges or portable stairs.

2.0 AIRPLANE DESCRIPTION

2.1 General Characteristics

2.2 General Dimensions

2.3 Ground Clearances

2.4 Interior Arrangements

2.5 Cabin Cross Sections

2.6 Lower Cargo Compartments

2.7 Door Clearances

2.0 AIRPLANE DESCRIPTION

2.1 General Characteristics

Maximum Design Taxi Weight (MTW). Maximum weight for ground maneuver as limited by aircraft strength and airworthiness requirements. (It includes weight of taxi and run-up fuel.)

Maximum Design Landing Weight (MLW). Maximum weight for landing as limited by aircraft strength and airworthiness requirements.

Maximum Design Takeoff Weight (MTOW). Maximum weight for takeoff as limited by aircraft strength and airworthiness requirements. (This is the maximum weight at start of the takeoff run.)

Operating Empty Weight (OEW). Weight of structure, powerplant, furnishing systems, unusable fuel and other unusable propulsion agents, and other items of equipment that are considered an integral part of a particular airplane configuration. Also included are certain standard items, personnel, equipment, and supplies necessary for full operations, excluding usable fuel and payload.

Maximum Design Zero Fuel Weight (MZFW). Maximum weight allowed before usable fuel and other specified usable agents must be loaded in defined sections of the aircraft as limited by strength and airworthiness requirements.

Maximum Payload. Maximum design zero fuel weight minus operational empty weight.

Maximum Seating Capacity. The maximum number of passengers specifically certificated or anticipated for certification.

Maximum Cargo Volume. The maximum space available for cargo.

Usable Fuel. Fuel available for aircraft propulsion.

CHARACTERISTICS	UNITS	BASIC AIRPLANE				HIGH GROSS WEIGHT OPTION
MAX DESIGN TAXI WEIGHT	POUNDS	111,000	115,000	117,000	119,000	122,000
	KILOGRAMS	50,349	52,163	53,070	53,977	55,338
MAX DESIGN TAKEOFF WEIGHT	POUNDS	110,000	114,000	116,000	118,000	121,000
	KILOGRAMS	49,895	51,709	52,617	53,524	54,884
MAX DESIGN LANDING WEIGHT	POUNDS	100,000	102,000	102,000	102,000	110,000
	KILOGRAMS	45,362	46,269	46,269	46,269	49,898
MAX DESIGN ZERO FUEL WEIGHT	POUNDS	94,000	96,000	96,000	96,000	100,500
	KILOGRAMS	42,638	43,545	43,545	43,545	45,586
SPEC OPERATING EMPTY WEIGHT (1)	POUNDS	67,500	67,500	67,500	67,500	68,500
	KILOGRAMS	30,617	30,617	30,617	30,617	31,071
MAX STRUCTURAL PAYLOAD	POUNDS	26,500	28,500	28,500	28,500	32,000
	KILOGRAMS	12,020	12,928	12,928	12,928	14,515
SEATING CAPACITY	MIXED CLASS	106	106	106	106	106
MAX CARGO - LOWER DECK	CUBIC FEET	935	935	935	935	730
	CUBIC METERS	26.5	26.5	26.5	26.5	20.7
USABLE FUEL	US GALLONS	3,673	3,673	3,673	3,673	4,403(2)
	LITERS	13,903	13,903	13,903	13,903	16,665(2)
	POUNDS	24,609	24,609	24,609	24,609	29,500(2)
	KILOGRAMS	11,163	11,163	11,163	11,163	13,382(2)

- NOTES: (1) TYPICAL SPEC OPERATING WEIGHT FOR A CONFIGURATION OF 106 PASSENGERS. CONSULT WITH AIRLINE FOR SPECIFIC WEIGHTS AND CONFIGURATIONS. DELIVERED AIRPLANES MAY HAVE DIFFERENT WEIGHTS DEPENDING ON AIRLINE REQUIREMENT.
- (2) INCLUDES OPTIONAL FWD 460 GAL AND AFT 270 GAL AUX FUEL TANKS.

2.1 GENERAL CHARACTERISTICS

MODEL 717-200

D6-58330

REV B

NOVEMBER 2014 7

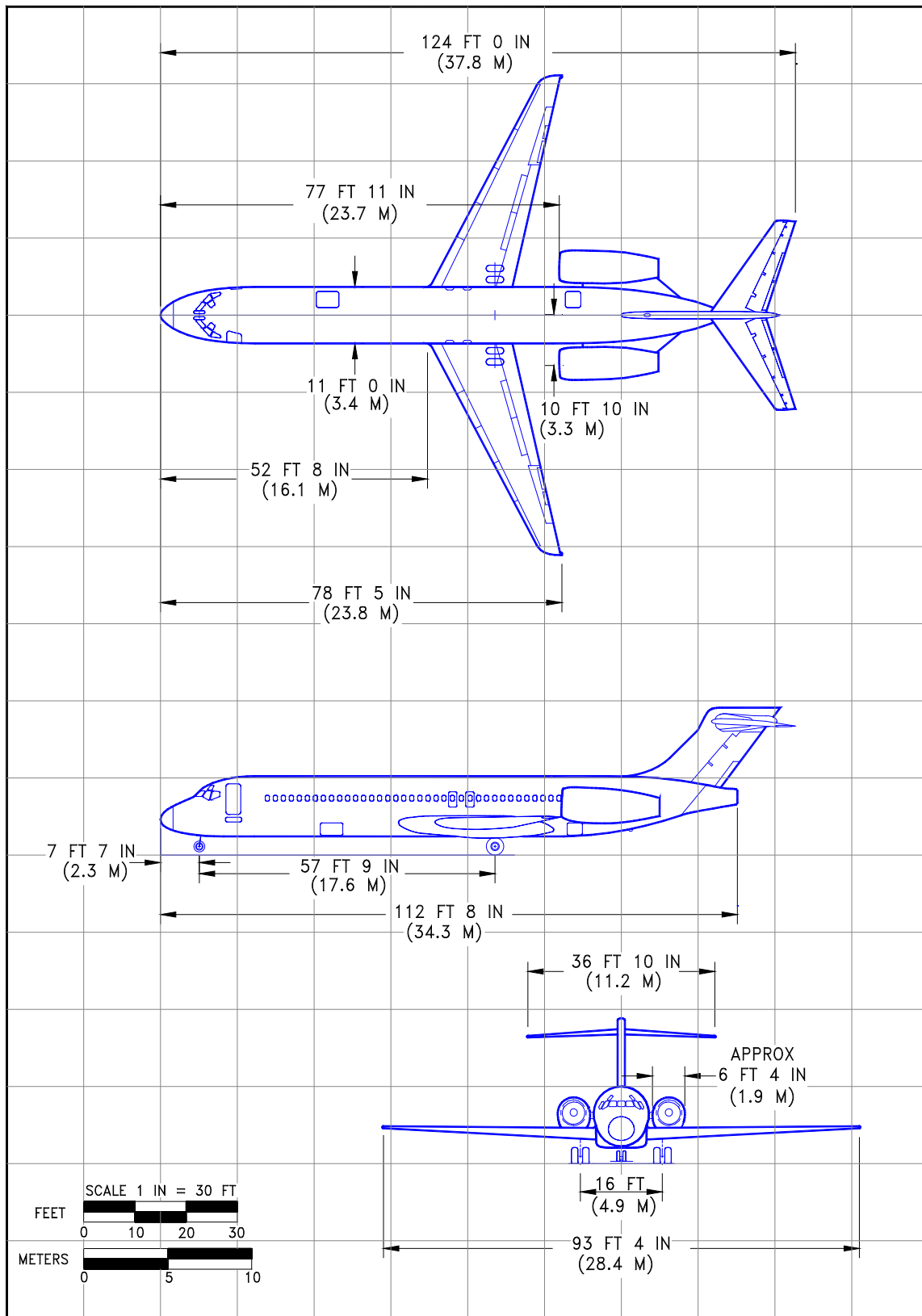

2.2 GENERAL DIMENSIONS
MODEL 717-200

D6-58330

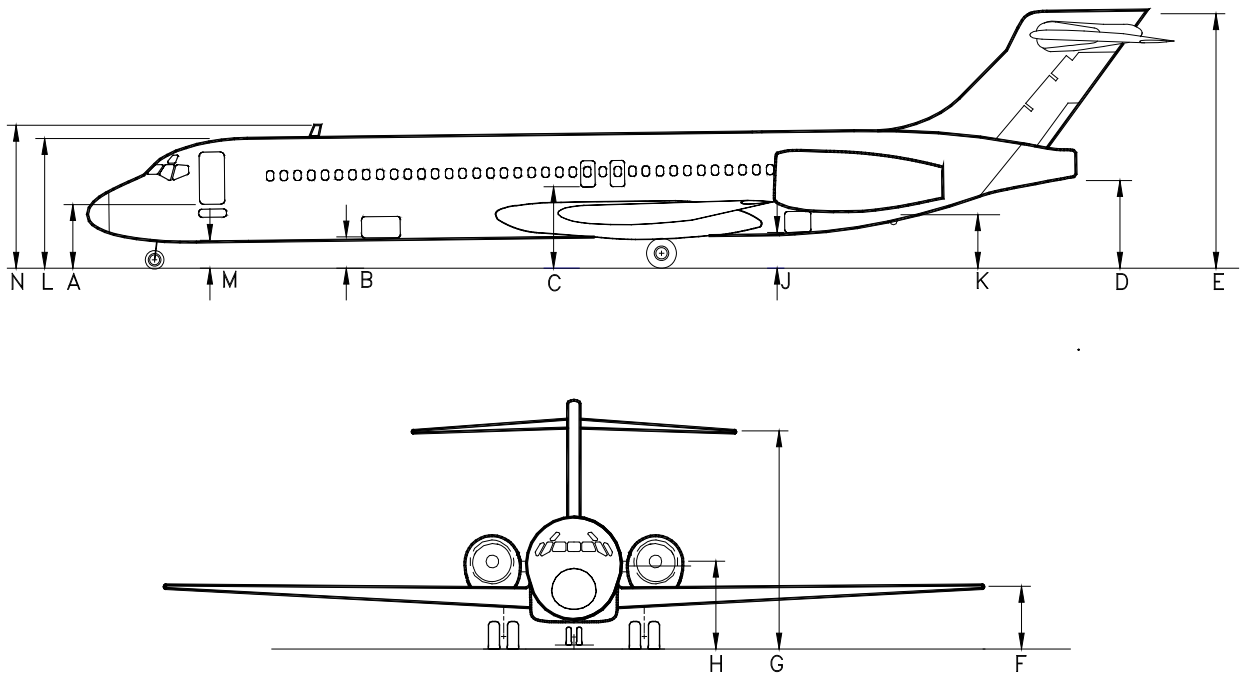

	MINIMUM		MAXIMUM	
	FEET - INCHES	METERS	FEET - INCHES	METERS
A	7-3	2.2	8-1	2.5
B	3-7	1.1	4-3	1.3
C	9-1	2.8	9-5	2.9
D	9-9	3.0	10-7	3.2
E	28-9	8.8	29-8	9.0
F	7-2	2.2	7-8	2.3
G	25-2	7.7	26-1	7.9
H	9-8	2.9	10-3	3.1
J	3-10	1.2	4-5	1.3
K	6-0	1.8	6-7	2.0
L	14-10	4.5	15-7	4.8
M	3-0	0.9	3-9	1.1
N	16-4	5.0	17-1	5.2

NOTES: VERTICAL CLEARANCES SHOWN OCCUR DURING MAXIMUM VARIATIONS OF AIRPLANE ATTITUDE. COMBINATIONS OF AIRPLANE LOADING AND UNLOADING ACTIVITIES THAT PRODUCE THE GREATEST POSSIBLE VARIATIONS IN ATTITUDE WERE USED TO ESTABLISH THE VARIATIONS SHOWN. DURING ROUTINE SERVICING, THE AIRPLANE REMAINS RELATIVELY STABLE, PITCH AND ELEVATION CHANGES OCCURRING SLOWLY.

2.3 GROUND CLEARANCES

MODEL 717-200

D6-58330

REV B

NOVEMBER 2014 9

MIXED CLASS
 106 PASSENGERS
 FIRST CLASS – 8 SEATS ON 36 IN (91.4 CM) PITCH
 ECONOMY CLASS – 98 SEATS ON 32 IN (81.3 CM) PITCH

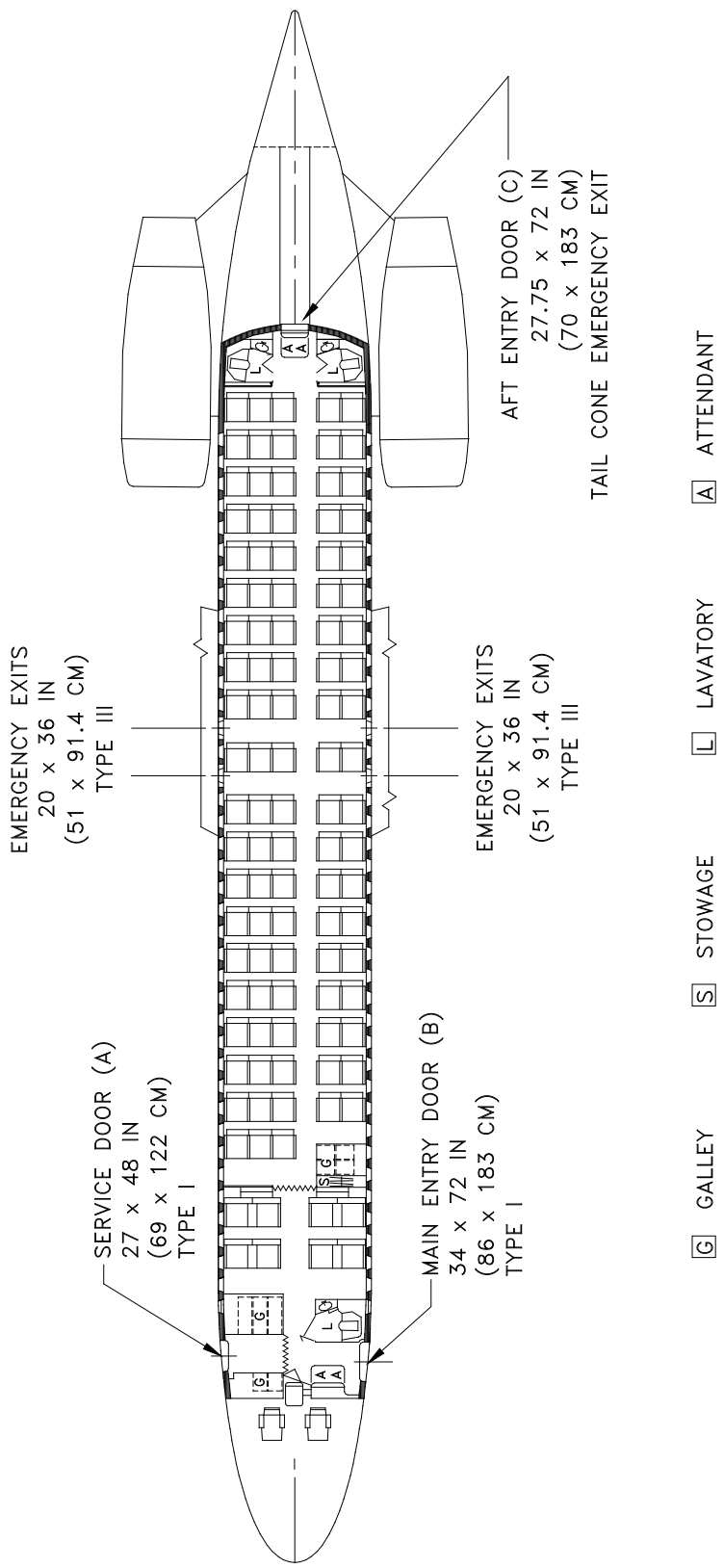

2.4.1 INTERIOR ARRANGEMENTS - MIXED CLASS CONFIGURATION
 MODEL 717-200

ALL ECONOMY CLASS
 117 PASSENGERS, 5-ABREAST SEATING ON 32 IN (81.3 CM) PITCH

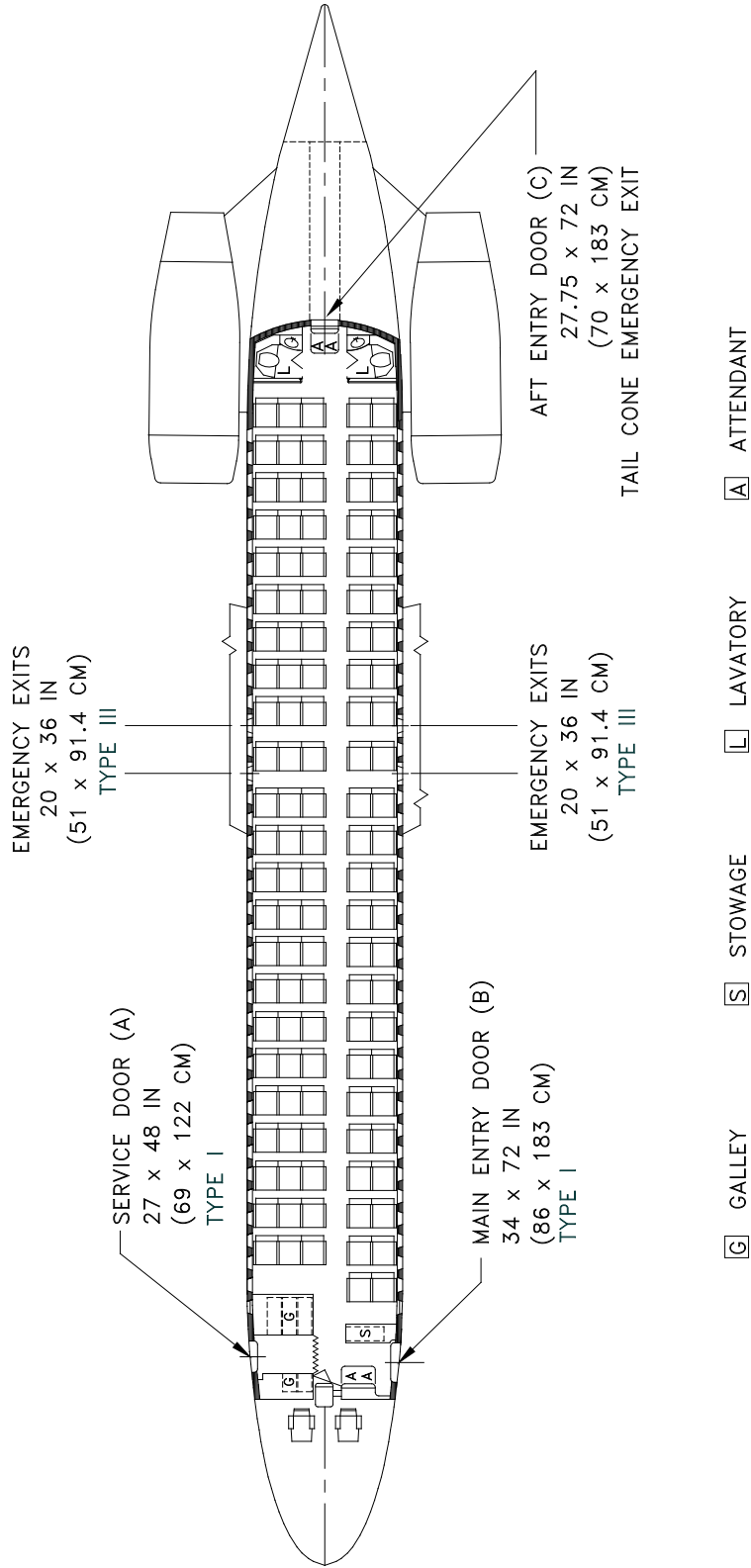

2.4.2 INTERIOR ARRANGEMENTS - ALL ECONOMY CONFIGURATION
 MODEL 717-200

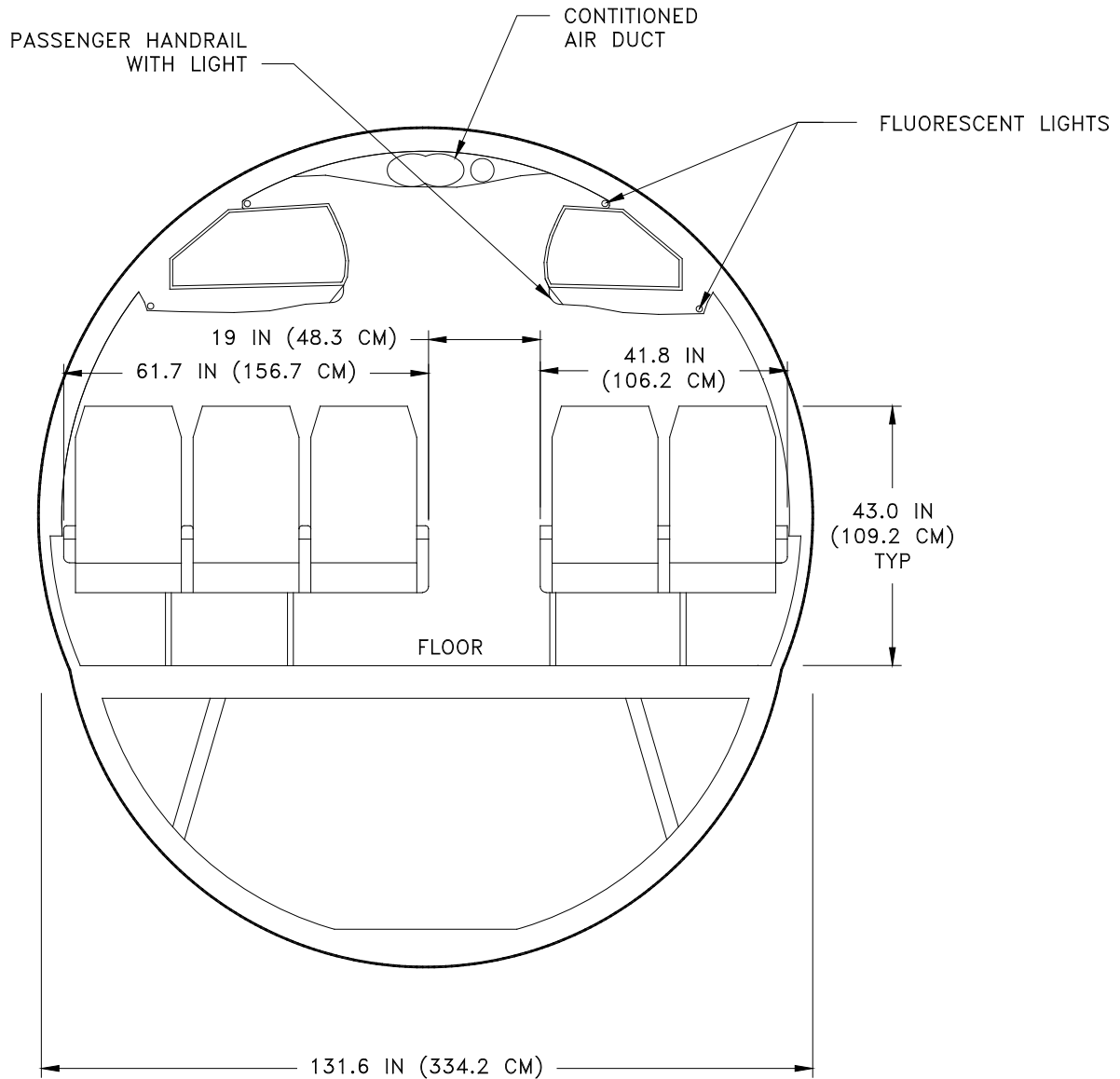

2.5.1 CABIN CROSS-SECTION - COACH SEATS
MODEL 717-200

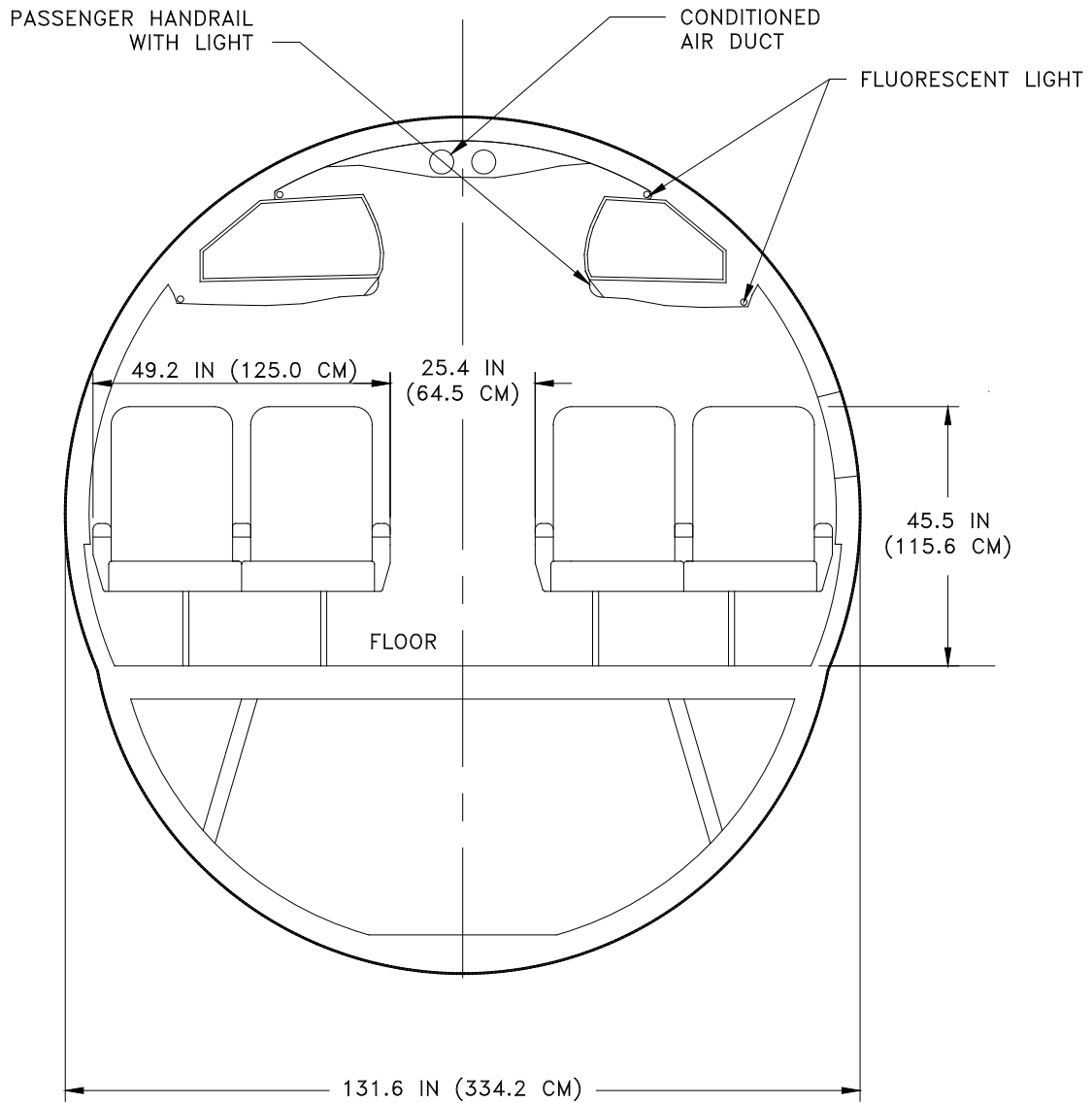

2.5.2 CABIN CROSS-SECTION - FIRST CLASS SEATS
MODEL 717-200

REV B

D6-58330

NOVEMBER 2014 13

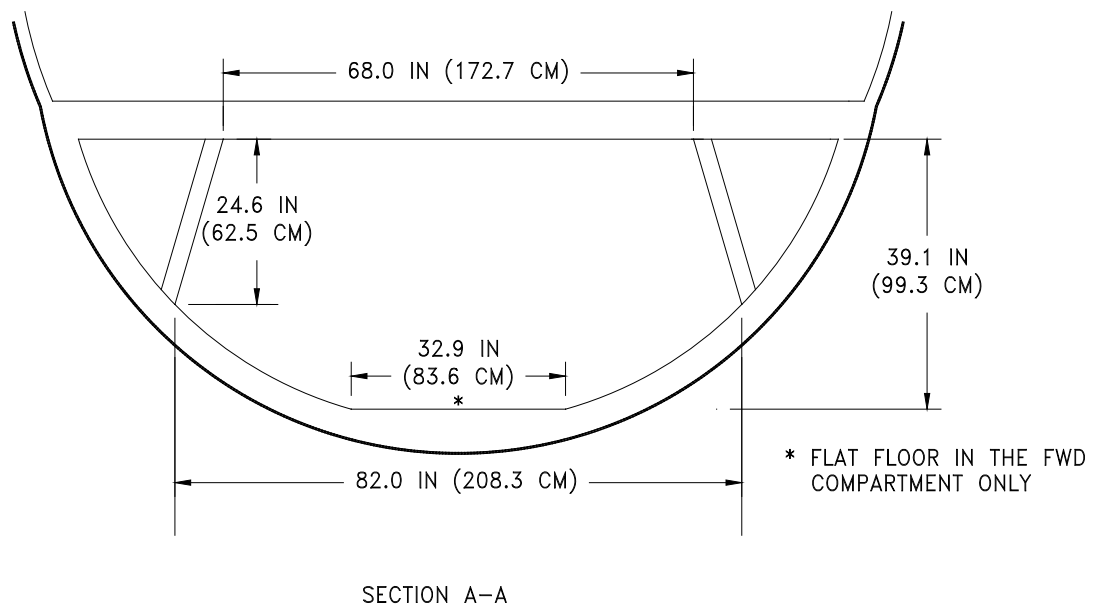
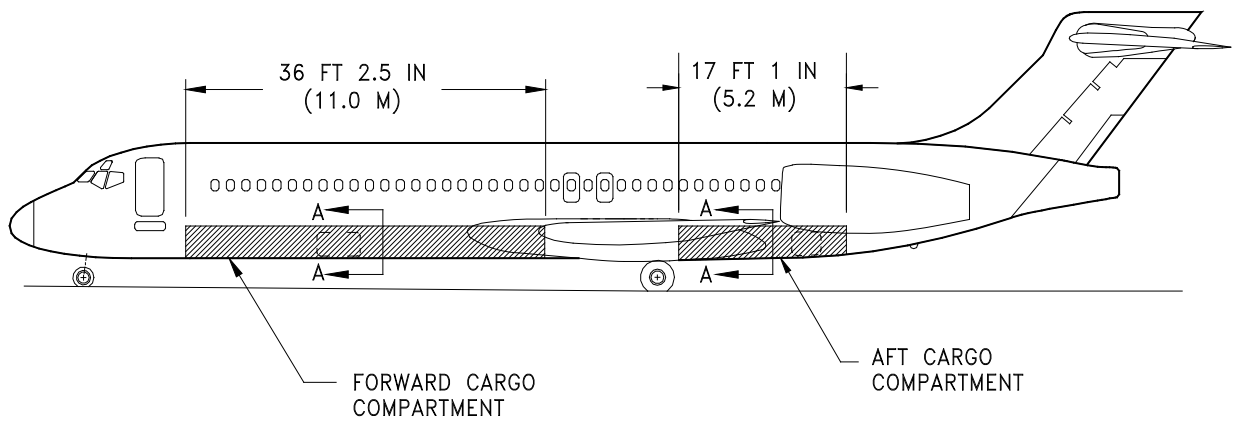

MODEL	FORWARD CARGO COMPARTMENT	AFT CARGO COMPARTMENT	TOTAL BULK CARGO
717-200 BASIC	646 CU FT (18.3 CU M)	289 CU FT (8.2 CU M)	935 CU FT (26.5 CU M)
717-200 HGW **	527 CU FT (14.9 CU M)	203 CU FT (5.7 CU M)	730 CU FT (20.7 CU M)

** SMALLER CAPACITIES FOR THE 717-200 HGW AIRPLANE ACCOUNT FOR THE OPTIONAL AUXILIARY FUEL TANKS IN THE FORWARD AND AFT COMPARTMENTS.

2.6 LOWER CARGO COMPARTMENTS - BULK CARGO CAPACITIES

MODEL 717-200

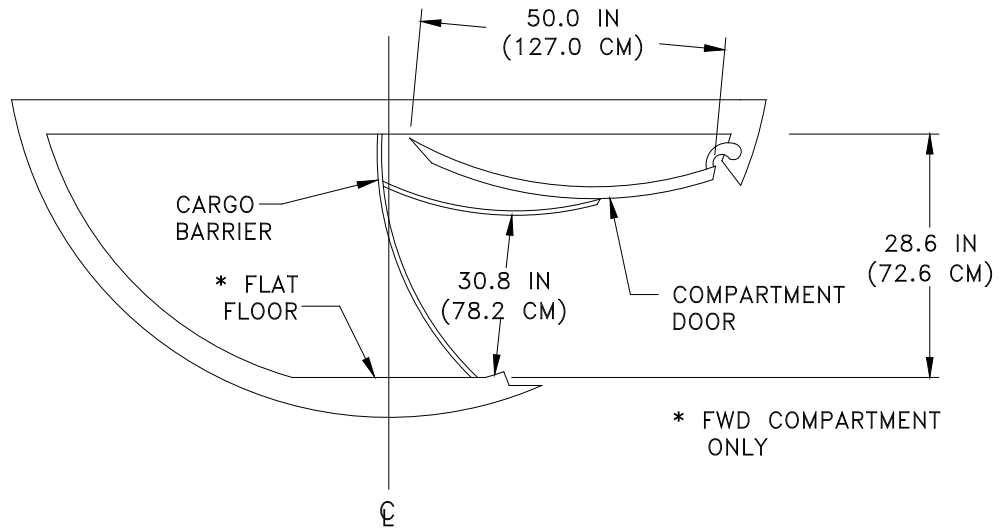
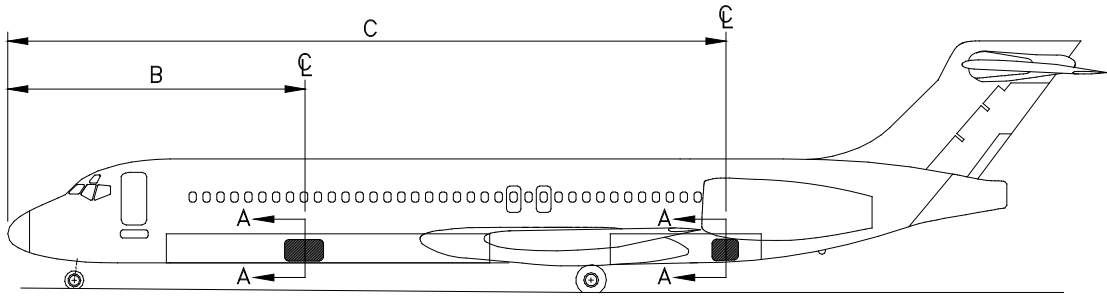

SECTION A - A

DOOR TYPE	DOOR SIZE	DISTANCE AFT OF NOSE TO DOOR CENTERLINE
FWD CARGO DOOR	53 x 50 IN (1.35 x 1.27 M)	(B) 32 FT 7.5 IN (9.9 M)
AFT CARGO DOOR	36 x 50 IN (0.91 x 1.27 M)	(C) 80 FT 7.0 IN (24.6 M)

2.7.1 FORWARD AND AFT CARGO DOOR CLEARANCES
MODEL 717-200

D6-58330

REV B

NOVEMBER 2014 15

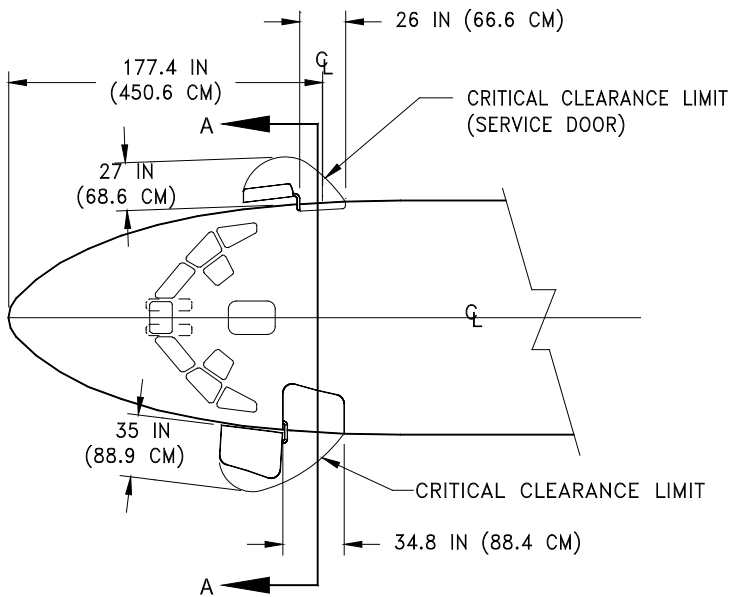

PARTIAL PLAN

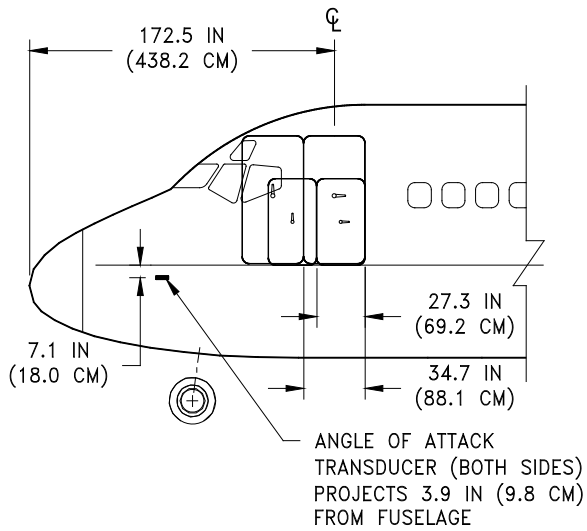

PARTIAL ELEVATION

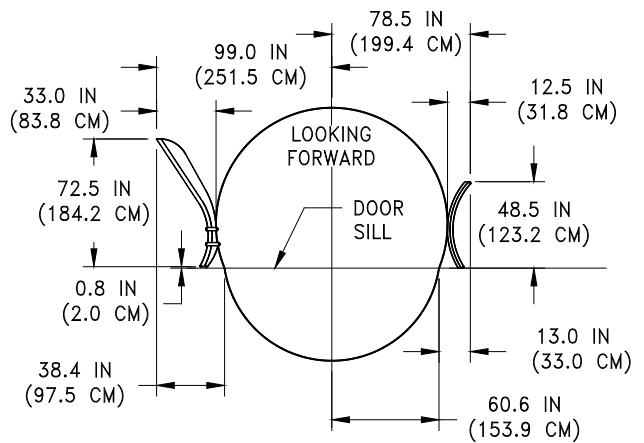

SECTION A - A

2.7.2 DOOR CLEARANCES
MODEL 717-200

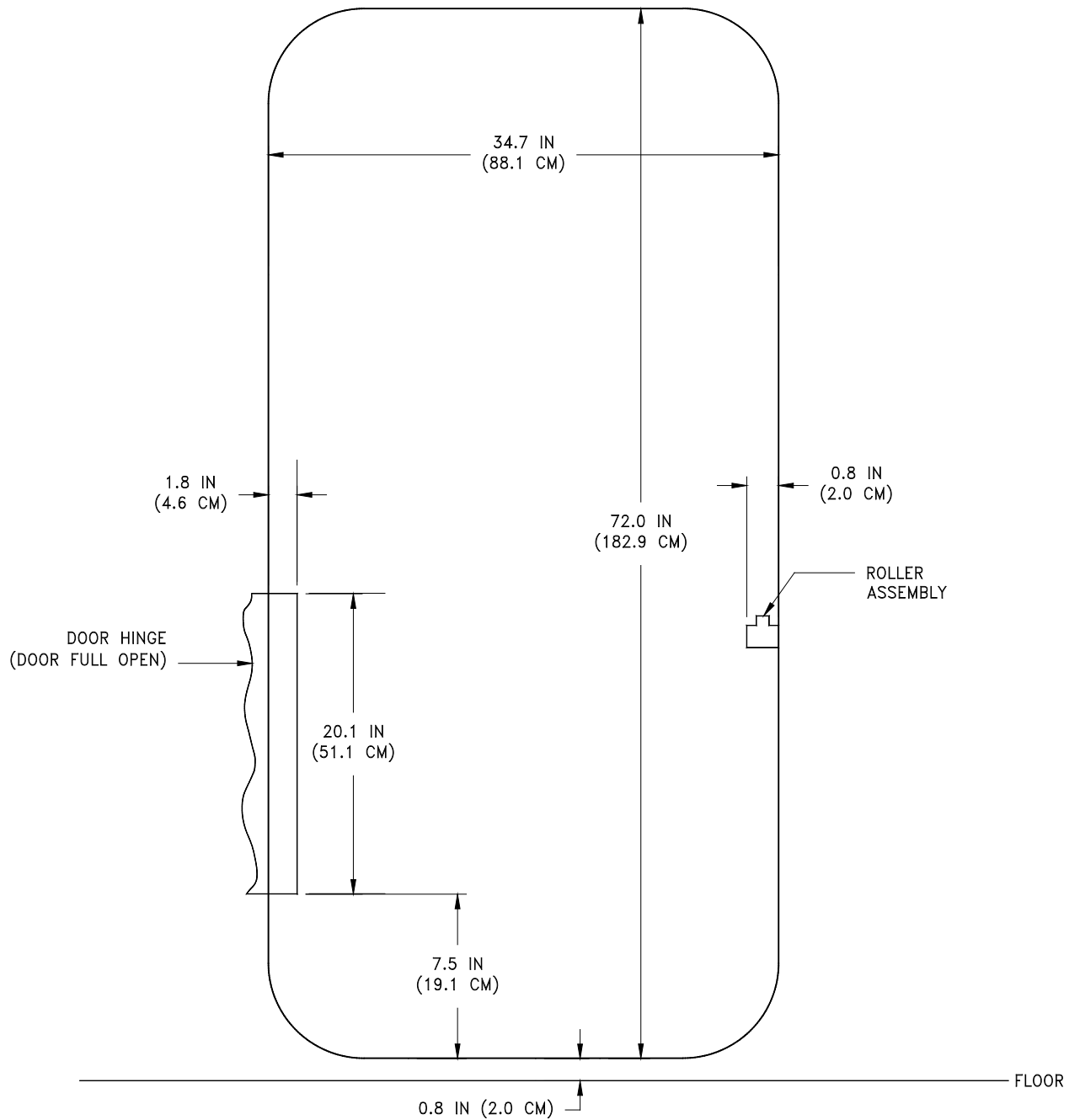

2.7.3 DOOR CLEARANCES - FORWARD PASSENGER DOOR OPENING CLEARANCES
MODEL 717-200

REV B

D6-58330

NOVEMBER 2014 17

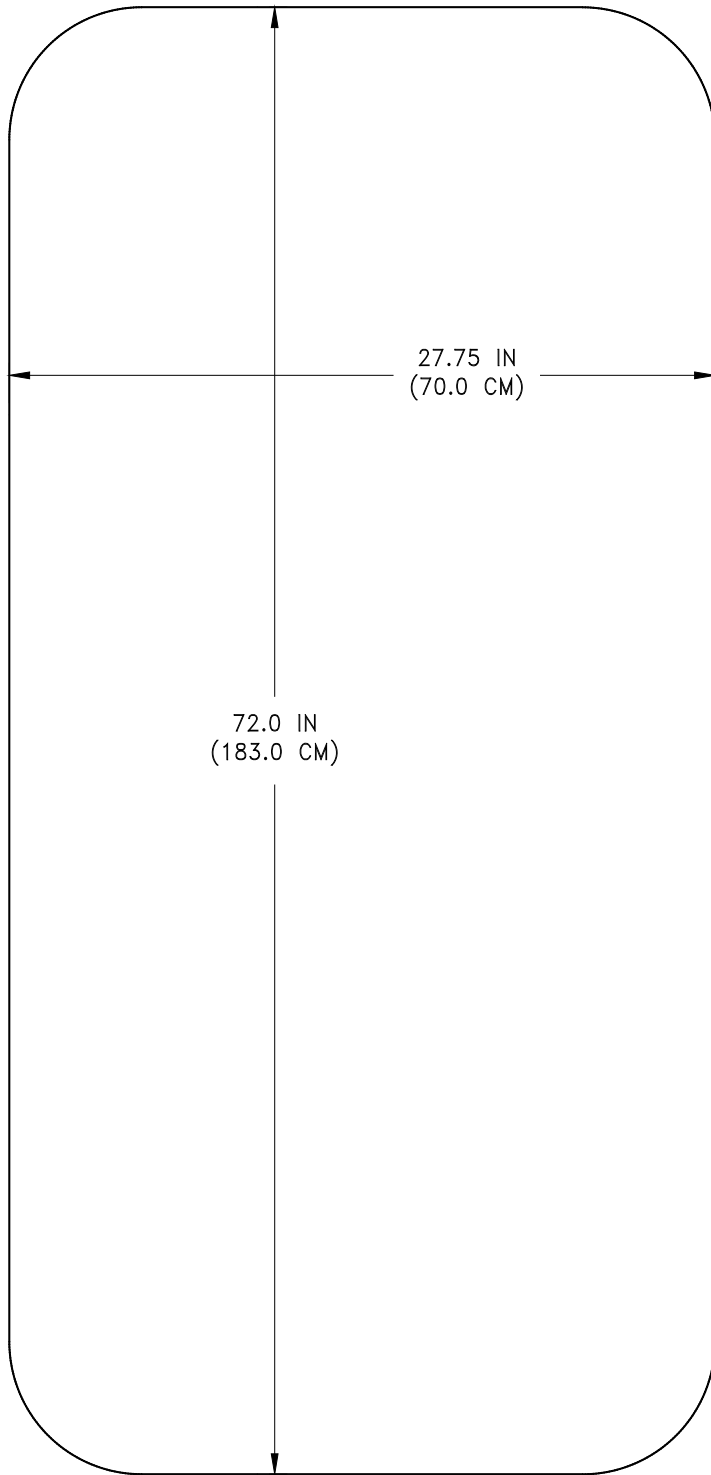

2.7.4 DOOR CLEARANCES - AFT PRESSURE BULKHEAD DOOR OPENING CLEARANCES
MODEL 717-200

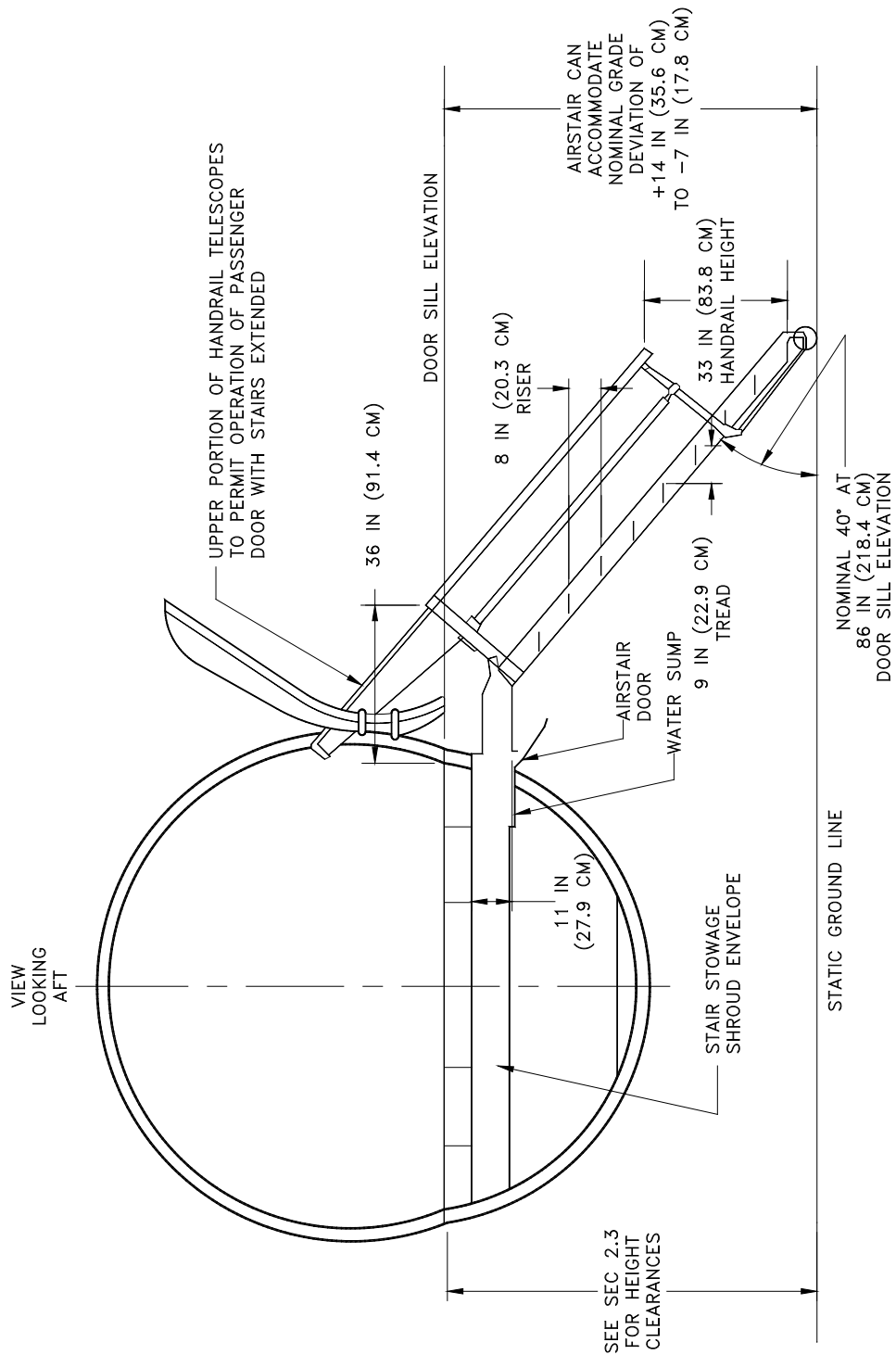

2.7.5 DOOR CLEARANCES – OPTIONAL FORWARD AIRSTAIR
MODEL 717-200

3.0 AIRPLANE PERFORMANCE

3.1 General Information

3.2 Payload/Range

3.3 F.A.R. Takeoff Runway Length Requirements

3.4 F.A.R. Landing Runway Length Requirements

3.0 AIRPLANE PERFORMANCE

3.1 General Information

The graph in Section 3.2 provides information on operating empty weight (OEW), payload, trip range, brake release gross weight, and fuel limits for a typical 717-200 airplane. To use this graph, if the trip range and zero fuel weight (OEW + payload) are known, the approximate brake release weight can be found, limited by fuel quantity.

The graphs in Section 3.3 provide information on F.A.R. takeoff runway length requirements with typical engines at different pressure altitudes. Maximum takeoff weights shown on the graphs are the heaviest for the particular airplane models with the corresponding engines. Standard day temperatures for pressure altitudes shown on the F.A.R. takeoff graphs are given below:

PRESSURE ALTITUDE		STANDARD DAY TEMP	
FEET	METERS	°F	°C
0	0	59.0	15.0
2,000	610	51.9	11.1
4,000	1,219	44.7	7.1
6,000	1,829	37.6	3.1
8,000	2,438	30.5	-0.8

Wet runway performance is shown in accordance with JAR-OPS 1 Subpart F, with wet runways defined in Paragraph 1.480(a)(10). Skid-resistant runways (grooved or PFC treated) per FAA or ICAO specifications exhibit runway length requirements that remove some or all of the length penalties associated with smooth (non-grooved) runways. Under predominantly wet conditions, the wet runway performance characteristics may be used to determine runway length requirements, if it is longer than the dry runway performance requirements.

The graph in Section 3.4 provides information on landing runway length requirements for different airplane weights and airport altitudes.

NOTES:

- * STANDARD DAY
- * ZERO WIND
- * BR715 ENGINES
- * RESERVES BASED ON 200 NMI ALTERNATE
- * CONSULT WITH USING AIRLINE FOR SPECIFIC PROCEDURE PRIOR TO FACILITY DESIGN

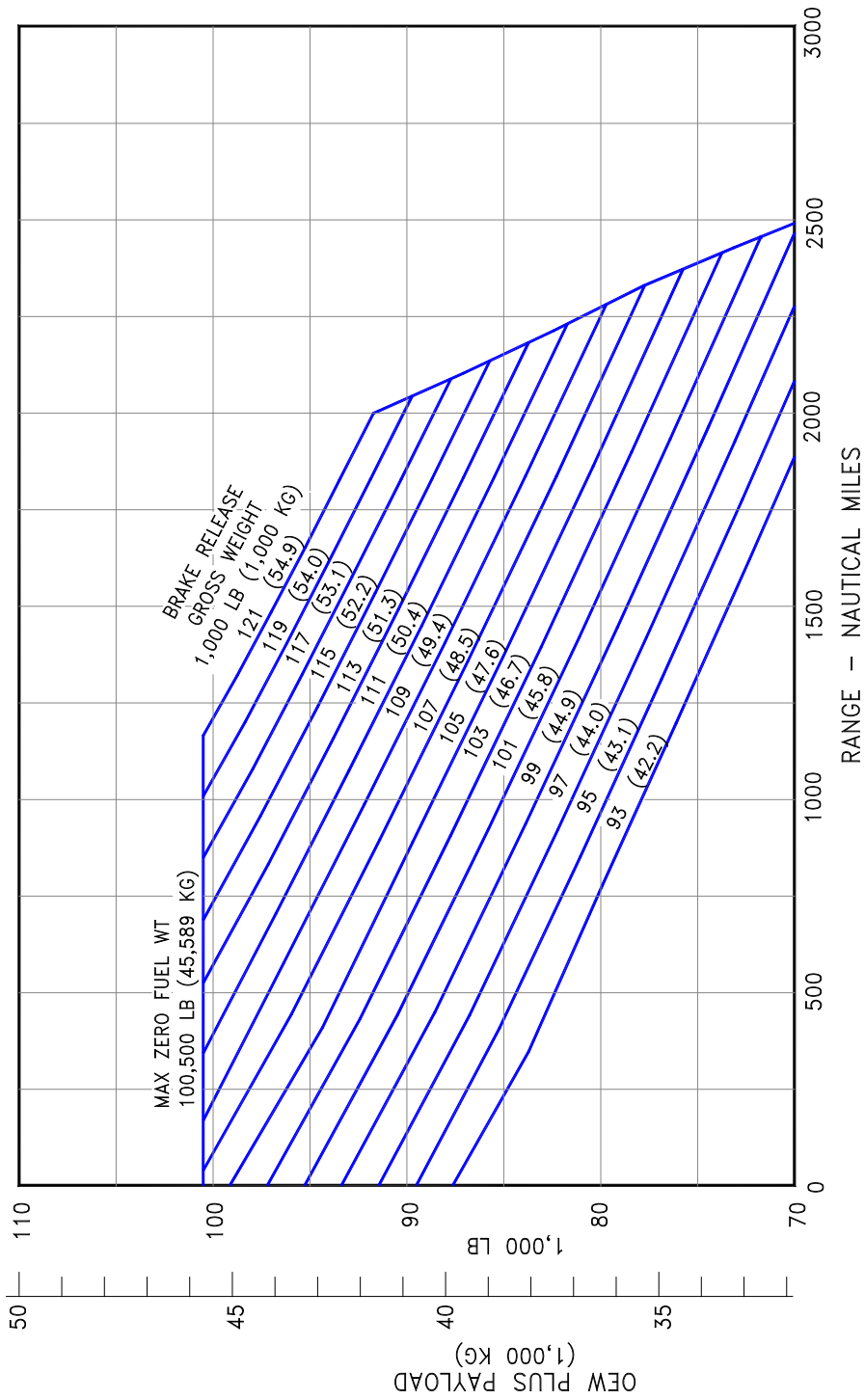

3.2. PAYLOAD/RANGE FOR LONG-RANGE CRUISE
MODEL 717-200

D6-58330

22 NOVEMBER 2014

REV B

- NOTES:
- * NO ENGINE AIRBLED FOR AIR CONDITIONING
 - * ZERO WIND, ZERO RUNWAY GRADIENT
 - * DRY RUNWAY SURFACE
 - * CONSULT USING AIRLINE FOR SPECIFIC OPERATING PROCEDURE PRIOR TO FACILITY DESIGN
 - * LINEAR INTERPOLATION BETWEEN ALTITUDES INVALID
 - * LINEAR INTERPOLATION BETWEEN TEMPERATURES INVALID

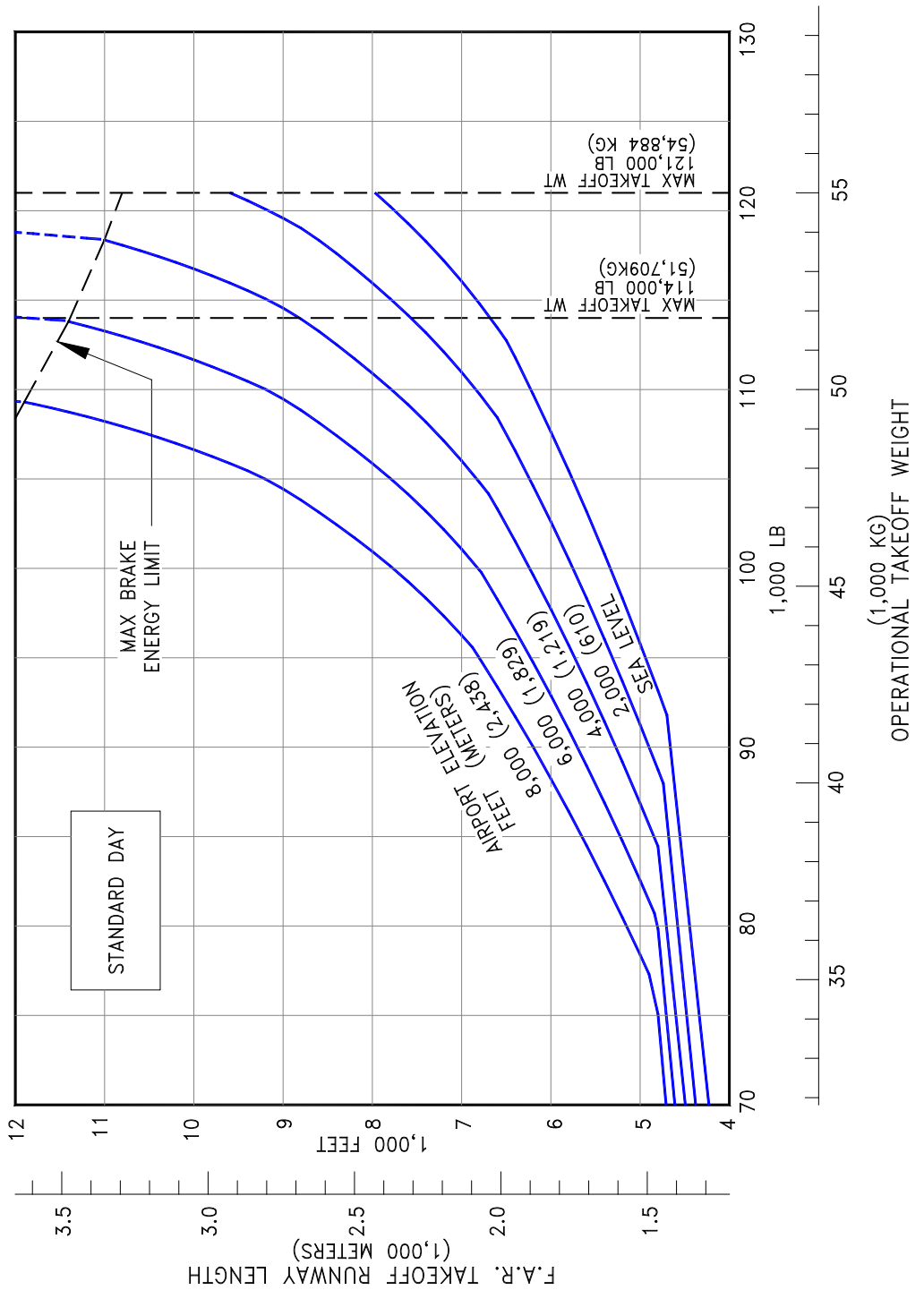

3.3.1 F.A.R. TAKEOFF RUNWAY LENGTH REQUIREMENTS - STANDARD DAY - DRY RUNWAY
MODEL 717-200 (BR715 ENGINES AT 18,500 LB THRUST)

D6-58330

REV B

NOVEMBER 2014 23

NOTES:

- * NO ENGINE AIRBLEED FOR AIR CONDITIONING
- * ZERO WIND, ZERO RUNWAY GRADIENT
- * DRY RUNWAY SURFACE
- * CONSULT USING AIRLINE FOR SPECIFIC OPERATING PROCEDURE PRIOR TO FACILITY DESIGN
- * LINEAR INTERPOLATION BETWEEN ALTITUDES INVALID
- * LINEAR INTERPOLATION BETWEEN TEMPERATURES INVALID

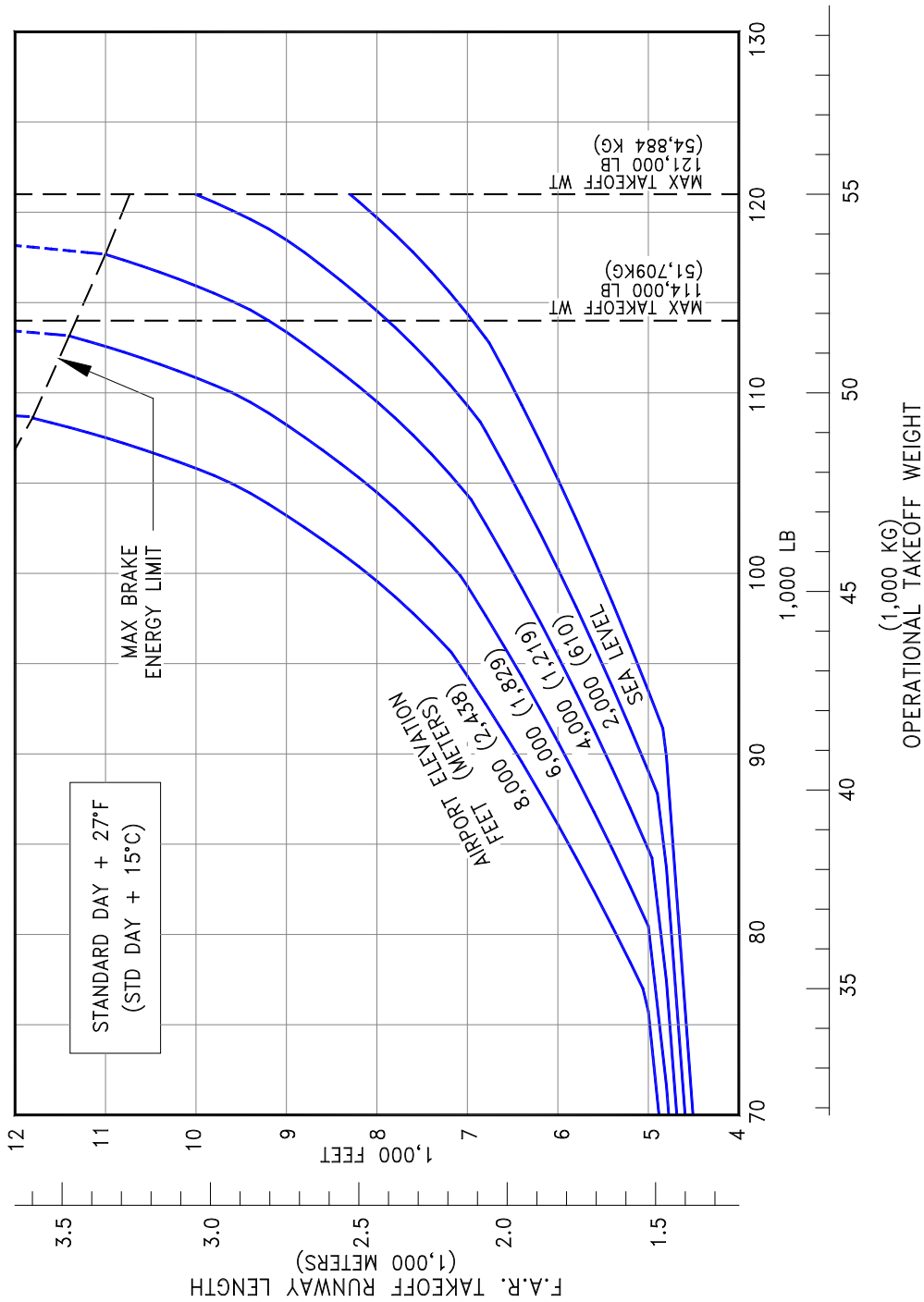

3.3.2 F.A.R. TAKEOFF RUNWAY LENGTH REQUIREMENTS - STANDARD DAY + 27°F (STD +15°C) - DRY RUNWAY MODEL 717-200 (BR715 ENGINES AT 18,500 LB THRUST)

NOTES:

- * NO ENGINE AIRBLEED FOR AIR CONDITIONING
- * ZERO WIND, ZERO RUNWAY GRADIENT
- * WET SMOOTH RUNWAY SURFACE
- * CONSULT USING AIRLINE FOR SPECIFIC OPERATING PROCEDURE PRIOR TO FACILITY DESIGN
- * LINEAR INTERPOLATION BETWEEN ALTITUDES INVALID
- * LINEAR INTERPOLATION BETWEEN TEMPERATURES INVALID

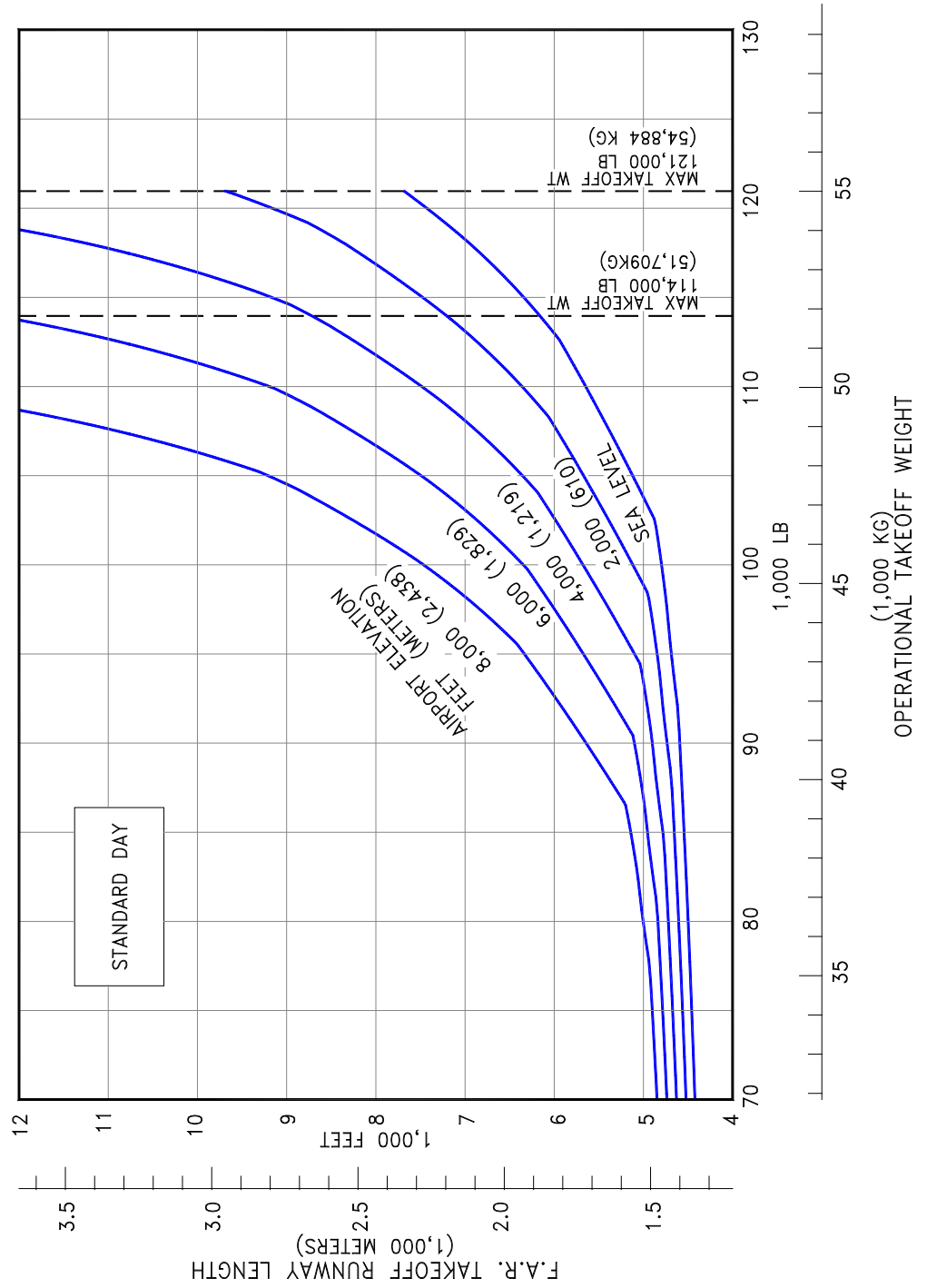

3.3.3 F.A.R. TAKEOFF RUNWAY LENGTH REQUIREMENTS - STANDARD DAY - WET SMOOTH RUNWAY
MODEL 717-200 (BR715 ENGINES AT 18,500 LB THRUST)

D6-58330

REV B

NOVEMBER 2014 25

- NOTES:
- * NO ENGINE AIRBLED FOR AIR CONDITIONING
 - * ZERO WIND, ZERO RUNWAY GRADIENT
 - * WET SMOOTH RUNWAY SURFACE
 - * CONSULT USING AIRLINE FOR SPECIFIC OPERATING PROCEDURE PRIOR TO FACILITY DESIGN
 - * LINEAR INTERPOLATION BETWEEN ALTITUDES INVALID
 - * LINEAR INTERPOLATION BETWEEN TEMPERATURES INVALID

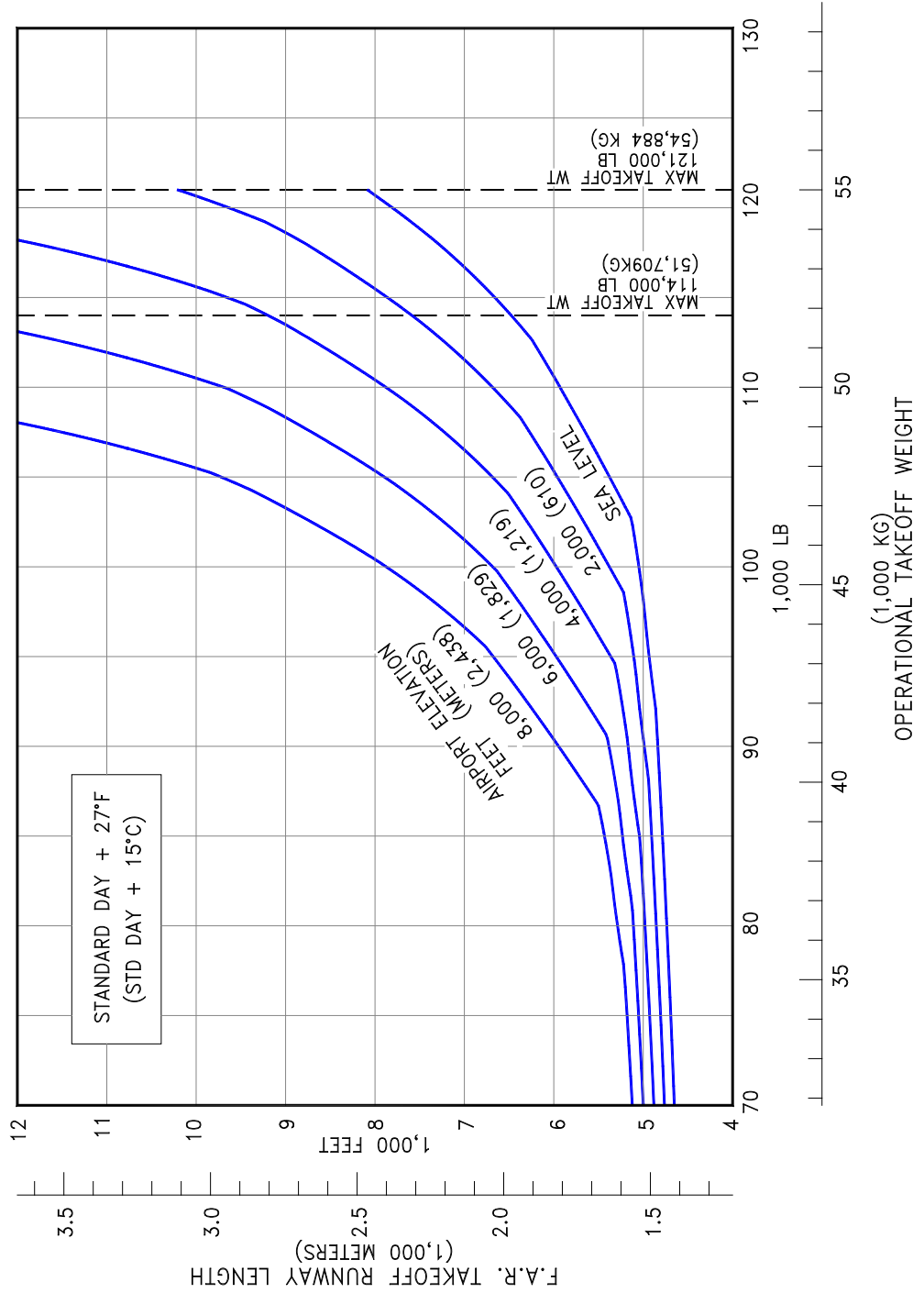

**3.3.4 F.A.R. TAKEOFF RUNWAY LENGTH REQUIREMENTS -
STANDARD DAY + 27°F (STD +15° C) - WET SMOOTH RUNWAY
MODEL 717-200 (BR715 ENGINES AT 18,500 LB THRUST)**

- NOTES:
- * NO ENGINE AIRBLED FOR AIR CONDITIONING
 - * ZERO WIND, ZERO RUNWAY GRADIENT
 - * DRY RUNWAY SURFACE
 - * CONSULT USING AIRLINE FOR SPECIFIC OPERATING PROCEDURE PRIOR TO FACILITY DESIGN
 - * LINEAR INTERPOLATION BETWEEN ALTITUDES INVALID
 - * LINEAR INTERPOLATION BETWEEN TEMPERATURES INVALID

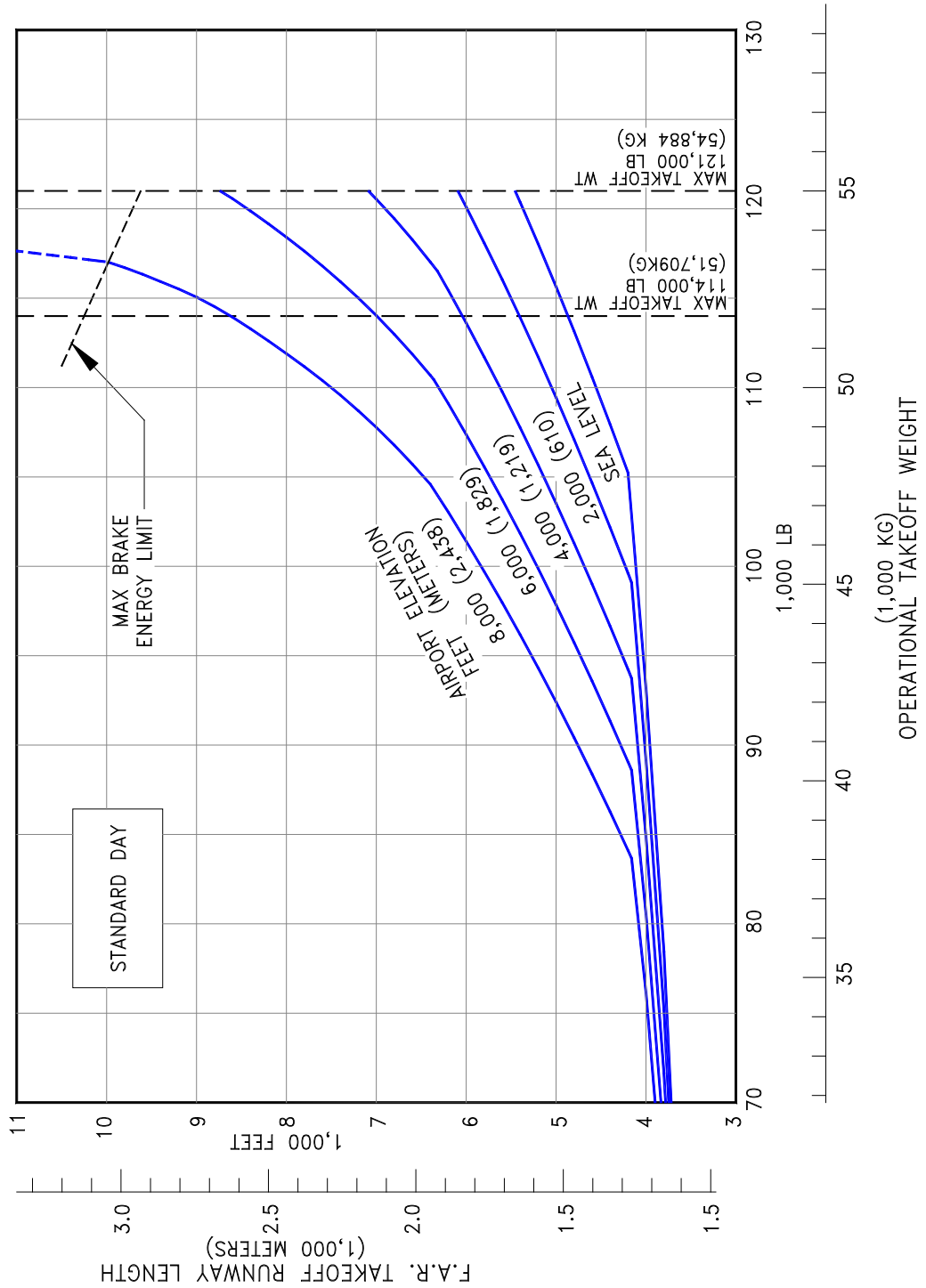

3.3.5 F.A.R. TAKEOFF RUNWAY LENGTH REQUIREMENTS - STANDARD DAY - DRY RUNWAY
 MODEL 717-200 (BR715 ENGINES AT 21,000 LB THRUST)

NOTES:

- * NO ENGINE AIRBLEED FOR AIR CONDITIONING
- * ZERO WIND, ZERO RUNWAY GRADIENT
- * DRY RUNWAY SURFACE
- * CONSULT USING AIRLINE FOR SPECIFIC OPERATING PROCEDURE PRIOR TO FACILITY DESIGN
- * LINEAR INTERPOLATION BETWEEN ALTITUDES INVALID
- * LINEAR INTERPOLATION BETWEEN TEMPERATURES INVALID

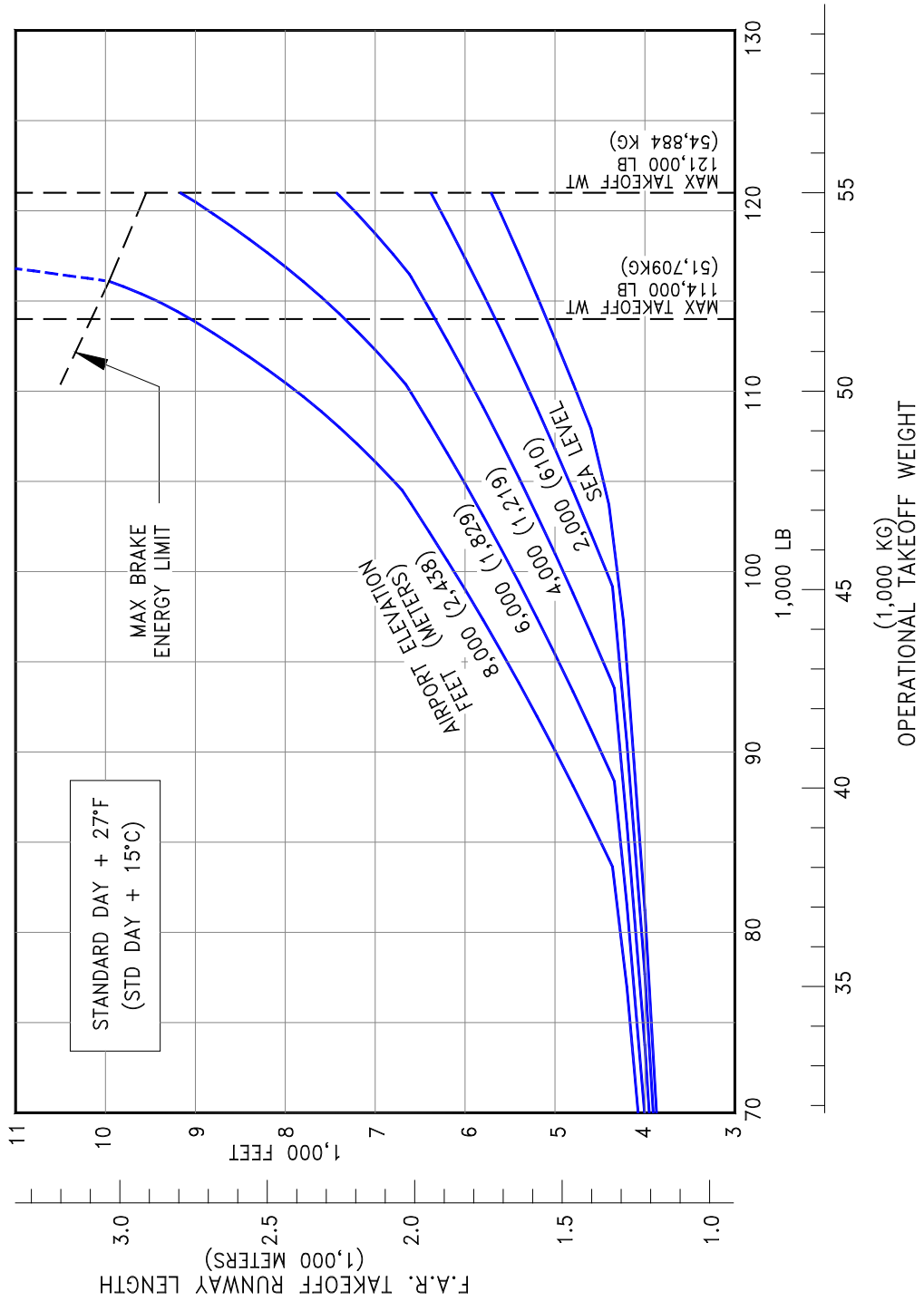

3.3.6 F.A.R. TAKEOFF RUNWAY LENGTH REQUIREMENTS - STANDARD DAY + 27°F (STD +15° C) - DRY RUNWAY MODEL 717-200 (BR715 ENGINES AT 21,000 LB THRUST)

NOTES:

- * NO ENGINE AIRBLED FOR AIR CONDITIONING
- * ZERO WIND, ZERO RUNWAY GRADIENT
- * WET SMOOTH RUNWAY SURFACE
- * CONSULT USING AIRLINE FOR SPECIFIC OPERATING PROCEDURE PRIOR TO FACILITY DESIGN
- * LINEAR INTERPOLATION BETWEEN ALTITUDES INVALID
- * LINEAR INTERPOLATION BETWEEN TEMPERATURES INVALID

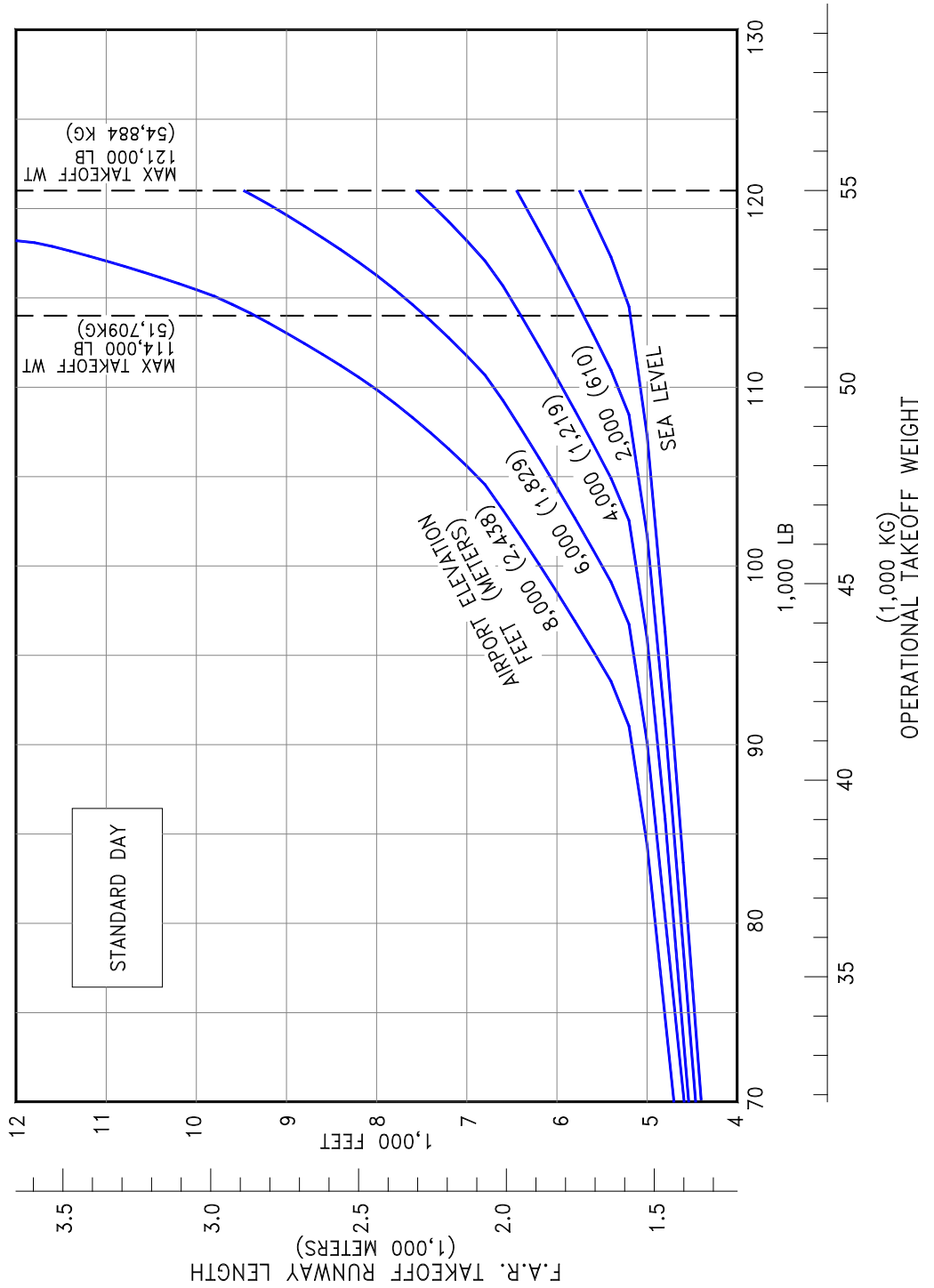

3.3.7 F.A.R. TAKEOFF RUNWAY LENGTH REQUIREMENTS - STANDARD DAY - WET SMOOTH RUNWAY
MODEL 717-200 (BR715 ENGINES AT 21,000 LB THRUST)

D6-58330

REV B

NOVEMBER 2014 29

- NOTES:
- * NO ENGINE AIRBLED FOR AIR CONDITIONING
 - * ZERO WIND, ZERO RUNWAY GRADIENT
 - * WET SMOOTH RUNWAY SURFACE
 - * CONSULT USING AIRLINE FOR SPECIFIC OPERATING PROCEDURE PRIOR TO FACILITY DESIGN
 - * LINEAR INTERPOLATION BETWEEN ALTITUDES INVALID
 - * LINEAR INTERPOLATION BETWEEN TEMPERATURES INVALID

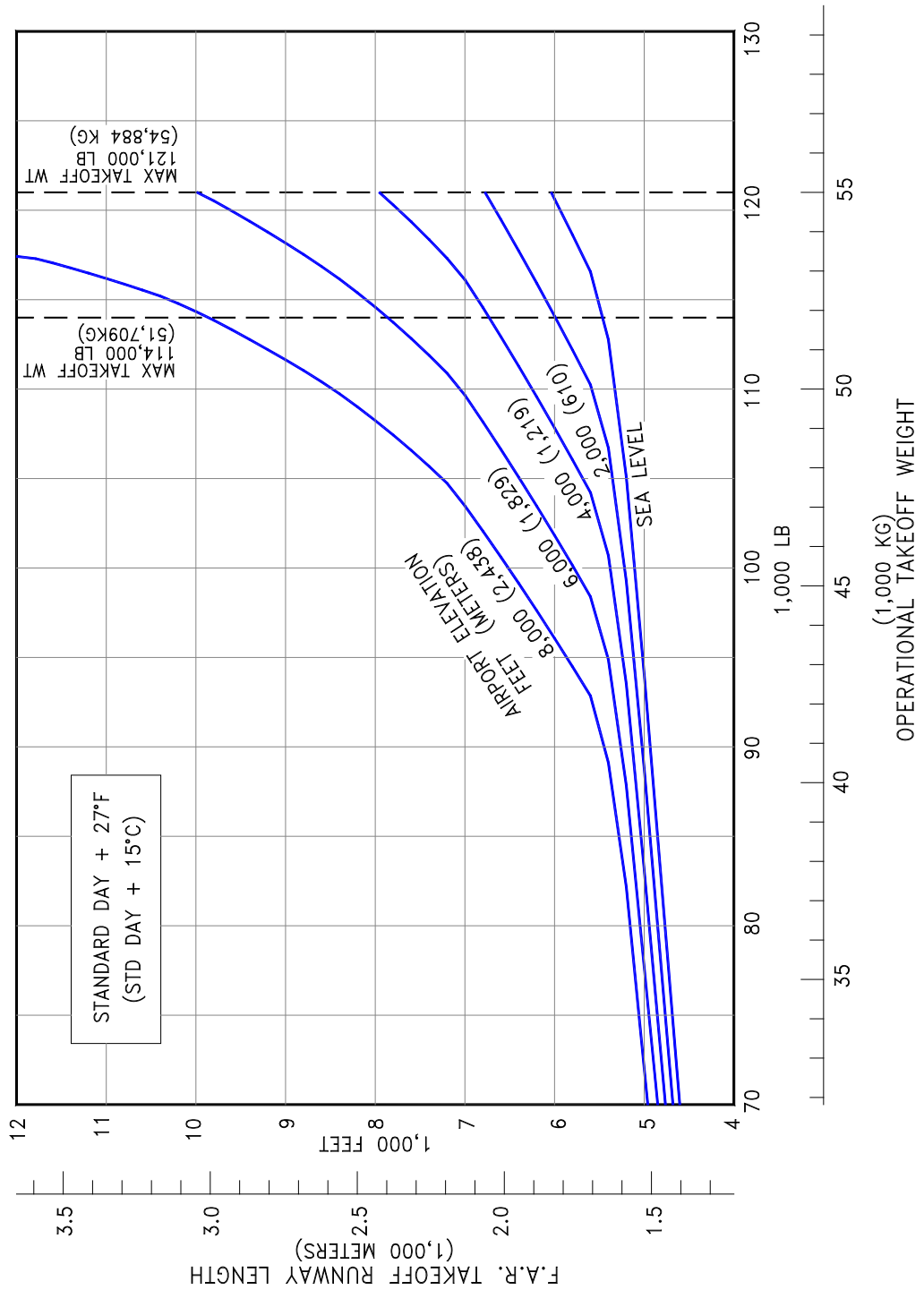

**3.3.8 F.A.R. TAKEOFF RUNWAY LENGTH REQUIREMENTS -
STANDARD DAY + 27°F (STD +15°C) - WET SMOOTH RUNWAY
MODEL 717-200 (BR715 ENGINES AT 21,000 LB THRUST)**

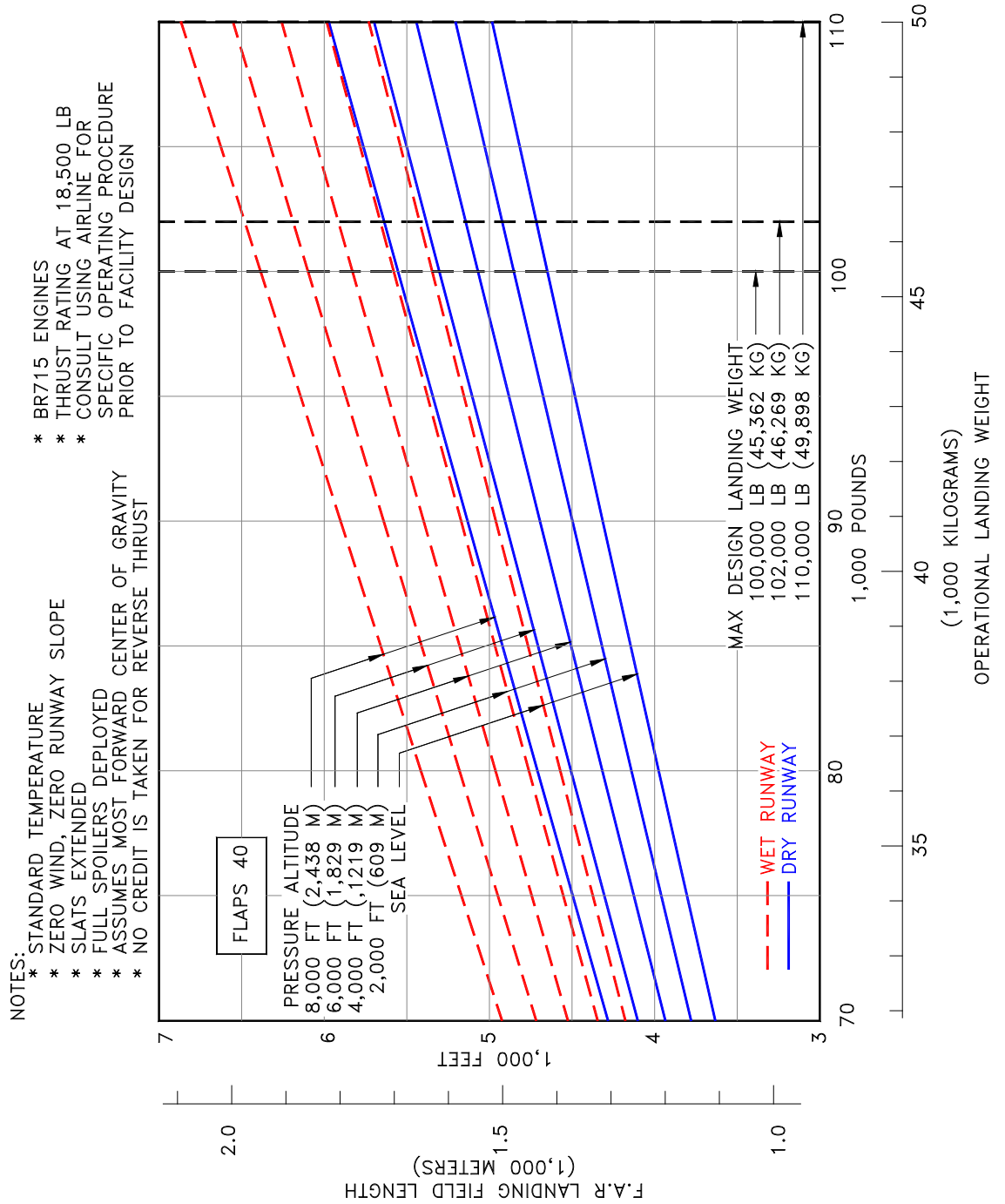

3.4.1 F.A.R. LANDING RUNWAY LENGTH REQUIREMENTS – FLAPS 40
MODEL 717-200

D6-58330

REV B

NOVEMBER 2014 31

4.0 GROUND MANEUVERING

4.1 General Information

4.2 Turning Radii

4.3 Clearance Radii

4.4 Visibility From Cockpit in Static Position

4.5 Runway and Taxiway Turn Paths

4.6 Runway Holding Bay

D6-58330

4.0 GROUND MANEUVERING

4.1 General Information

This section provides airplane turning capability and maneuvering characteristics.

For ease of presentation, these data have been determined from the theoretical limits imposed by the geometry of the aircraft, and where noted, provide for a normal allowance for tire slippage. As such, they reflect the turning capability of the aircraft in favorable operating circumstances. These data should be used only as guidelines for the method of determination of such parameters and for the maneuvering characteristics of this aircraft.

In the ground operating mode, varying airline practices may demand that more conservative turning procedures be adopted to avoid excessive tire wear and reduce possible maintenance problems. Airline operating procedures will vary in the level of performance over a wide range of operating circumstances throughout the world. Variations from standard aircraft operating patterns may be necessary to satisfy physical constraints within the maneuvering area, such as adverse grades, limited area, or high risk of jet blast damage. For these reasons, ground maneuvering requirements should be coordinated with the using airlines prior to layout planning.

Section 4.2 shows turning radii for various nose gear steering angles. Radii for the main and nose gears are measured from the turn center to the outside of the tire.

Section 4.3 provides data on minimum width of pavement required for 180° turn.

Section 4.4 shows the pilot's visibility from the cockpit and the limits of ambinoocular vision through the windows. Ambinoocular vision is defined as the total field of vision seen simultaneously by both eyes.

Section 4.5 shows wheel paths of a 717-200 on runway to taxiway, and taxiway to taxiway turns.

Section 4.6 illustrates a typical runway holding bay configuration.

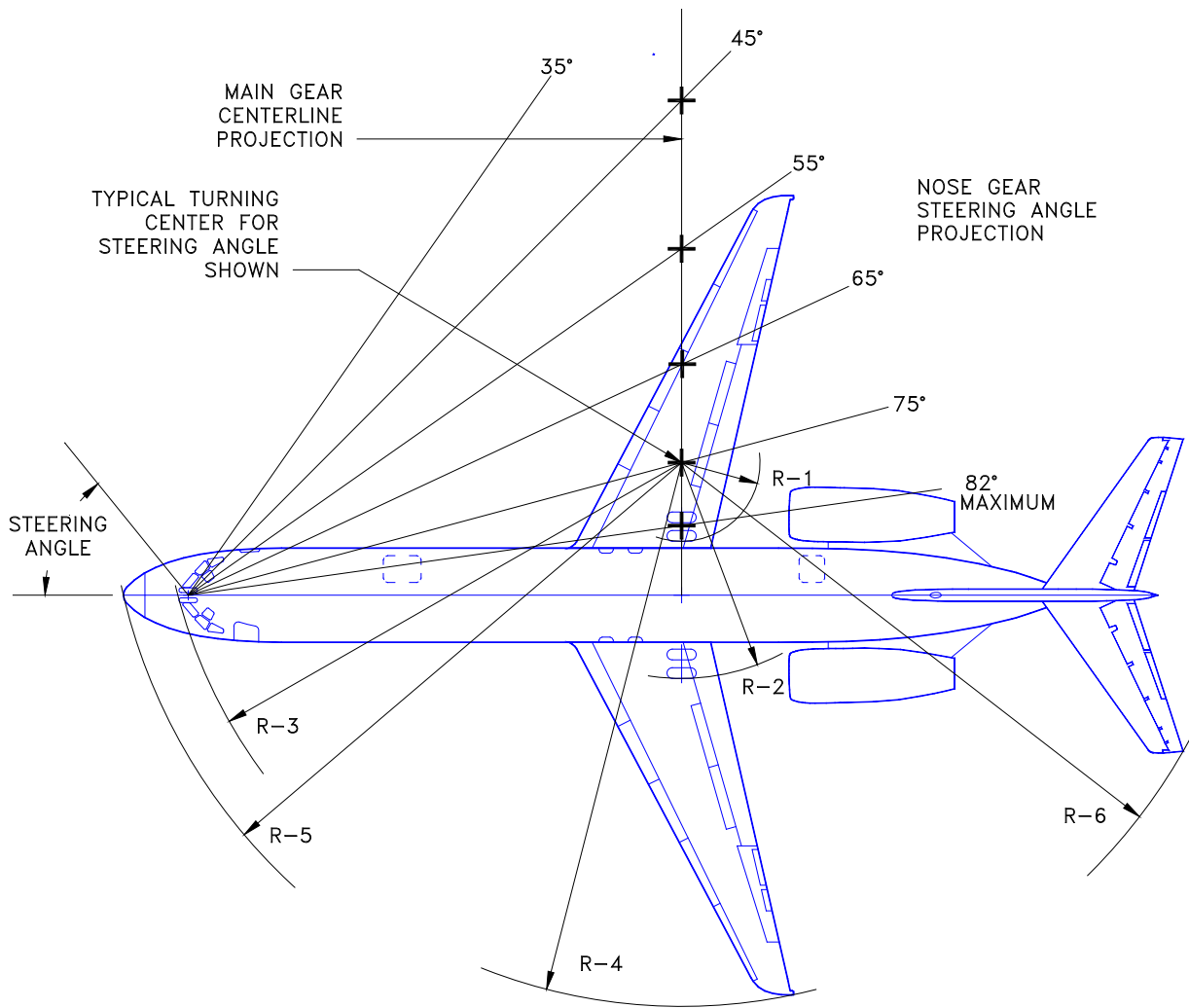

NOTES: * ACTUAL OPERATING TURNING RADII MAY BE GREATER THAN SHOWN.
 * CONSULT WITH AIRLINE FOR SPECIFIC OPERATING PROCEDURE
 * R-3 IS MEASURED TO OUTSIDE TIRE FACE

STEERING ANGLE (DEG)	R1 INNER GEAR		R2 OUTER GEAR		R3 NOSE GEAR		R4 WING TIP		R5 NOSE		R6 TAIL	
	FT	M	FT	M	FT	M	FT	M	FT	M	FT	M
30	93.7	28.6	109.7	33.4	115.5	35.2	147.2	44.9	119.5	36.4	132.0	40.2
35	76.2	23.2	92.2	28.1	101.5	30.9	129.8	39.6	105.2	32.1	116.5	35.5
40	62.5	19.1	78.5	23.9	89.8	27.4	116.2	35.4	94.9	28.9	104.9	32.0
45	51.5	15.7	67.5	20.5	82.5	25.2	105.2	32.1	87.1	26.6	96.0	29.3
50	42.2	12.8	58.2	17.7	76.2	23.2	96.0	29.3	81.3	24.8	88.8	27.1
55	34.1	10.4	50.1	15.3	71.3	21.7	88.0	26.8	76.8	23.4	82.9	25.3
60	27.0	8.2	43.1	13.1	67.5	20.6	81.0	24.7	73.3	22.3	78.1	23.8
65	20.6	6.3	36.6	11.2	64.5	19.7	74.7	22.8	70.6	21.5	74.0	22.6
70	14.7	4.5	30.7	9.4	62.3	19.0	68.9	21.0	68.6	20.9	70.6	21.5
75	9.2	2.8	25.2	7.7	60.6	18.5	63.4	19.3	67.1	20.5	67.6	20.6
82 (MAX)	1.8	0.5	17.8	5.4	59.1	18.0	56.2	17.1	65.8	20.1	64.3	19.6

4.2 TURNING RADII - NO SLIP ANGLE MODEL 717-200

D6-58330

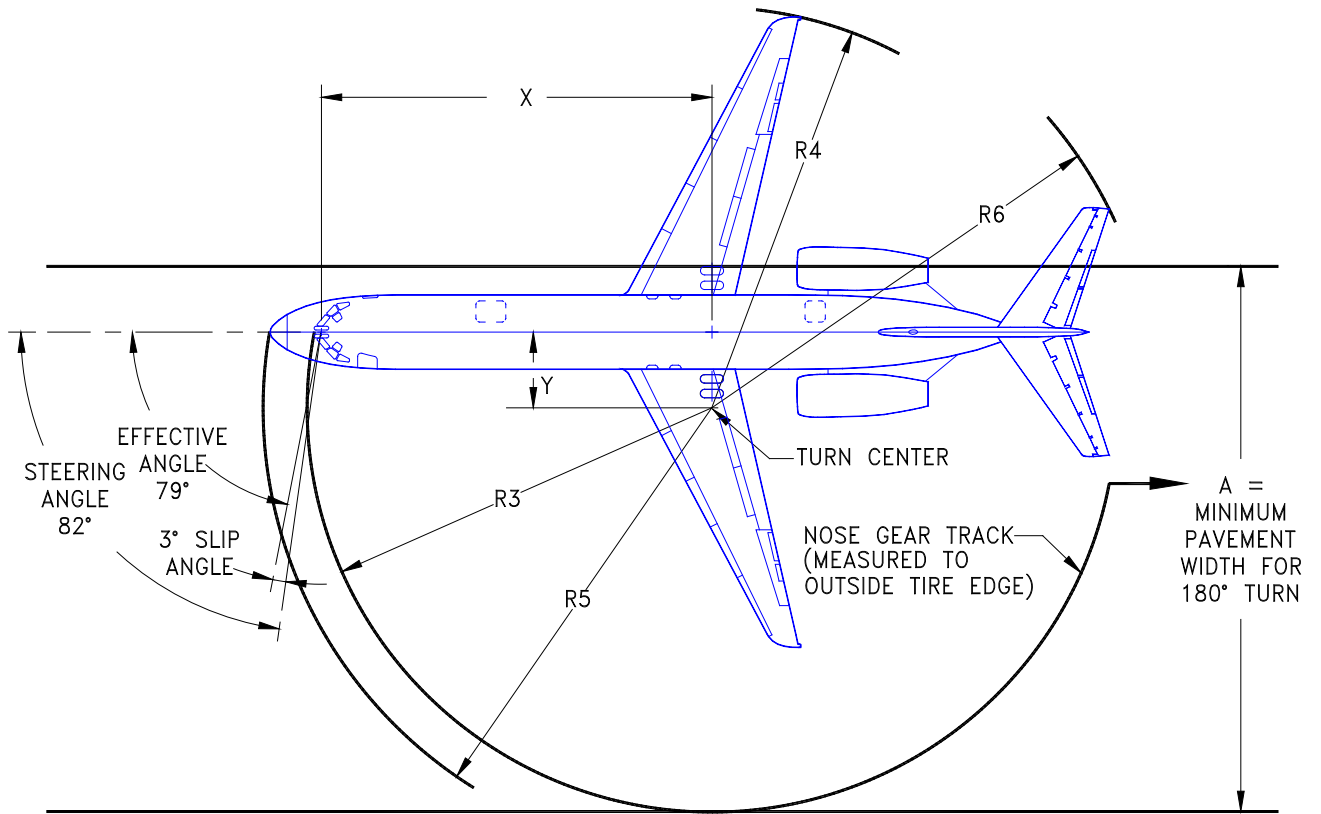

NOTES: * 3° TIRE SLIP ANGLE APPROXIMATE FOR 82° NOSE WHEEL STEERING ANGLE DURING VERY SLOW TURNING.
 * CONSULT WITH AIRLINE FOR SPECIFIC OPERATING DATA
 * NO DIFFERENTIAL BRAKING OR ASYMMETRICAL THRUST

EFFECTIVE TURN ANGLE	X		Y		A		R3		R4		R5		R6	
	FT	M	FT	M	FT	M	FT	M	FT	M	FT	M	FT	M
79°	57.75	17.6	11.2	3.4	80.6	24.6	59.7	18.2	59.3	18.1	66.3	20.2	65.8	20.0

4.3 CLEARANCE RADII
 MODEL 717-200

D6-58330

REV B

NOVEMBER 2014 35

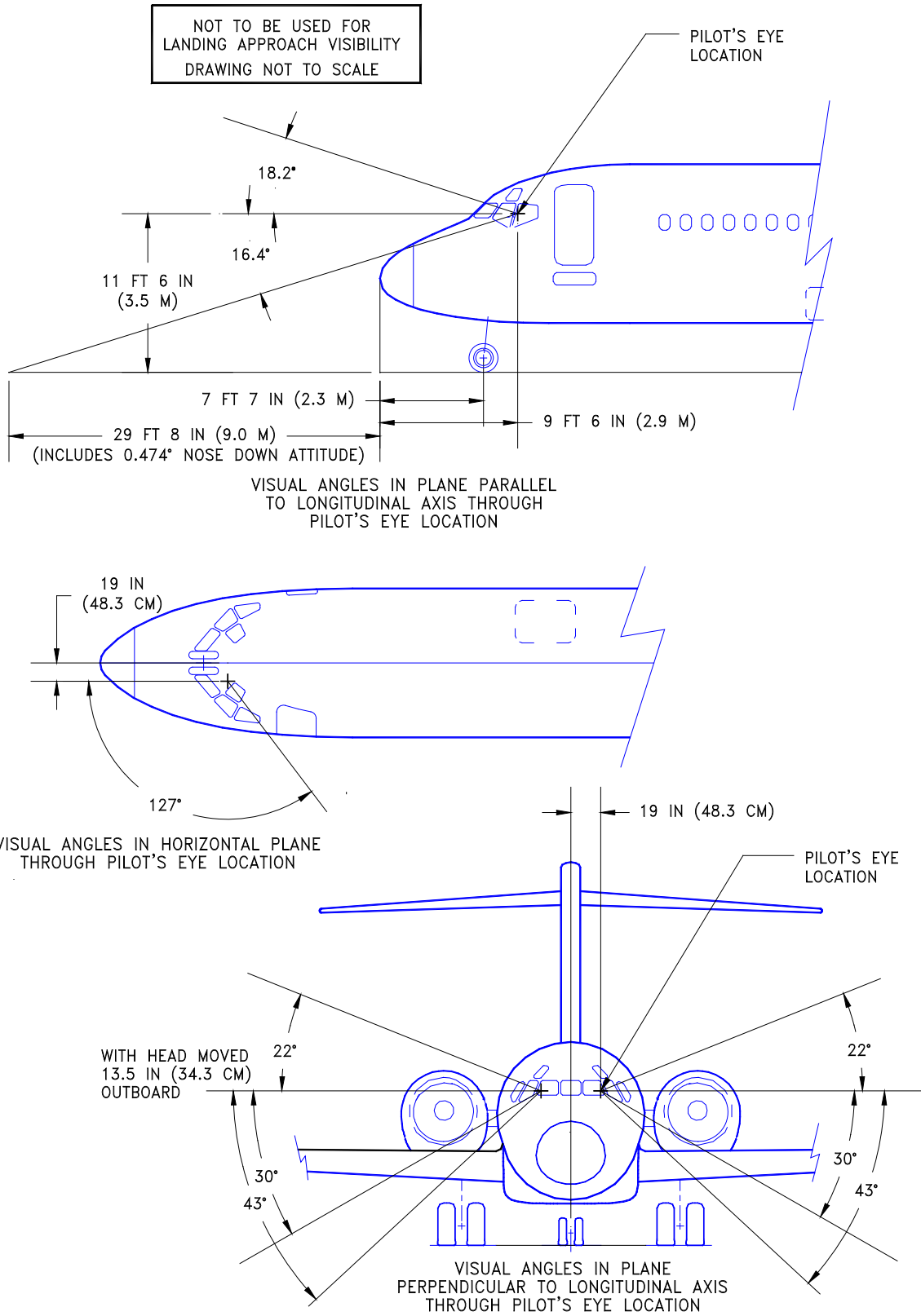

4.4 VISIBILITY FROM COCKPIT IN STATIC POSITION
MODEL 717-200

D6-58330

NOTE:
 BEFORE DETERMINING THE SIZE OF THE INTERSECTION FILLET, CHECK WITH THE AIRLINES REGARDING THE OPERATING PROCEDURES THAT THEY USE AND THE TYPES OF AIRCRAFT THAT ARE EXPECTED TO SERVE THE AIRPORT.

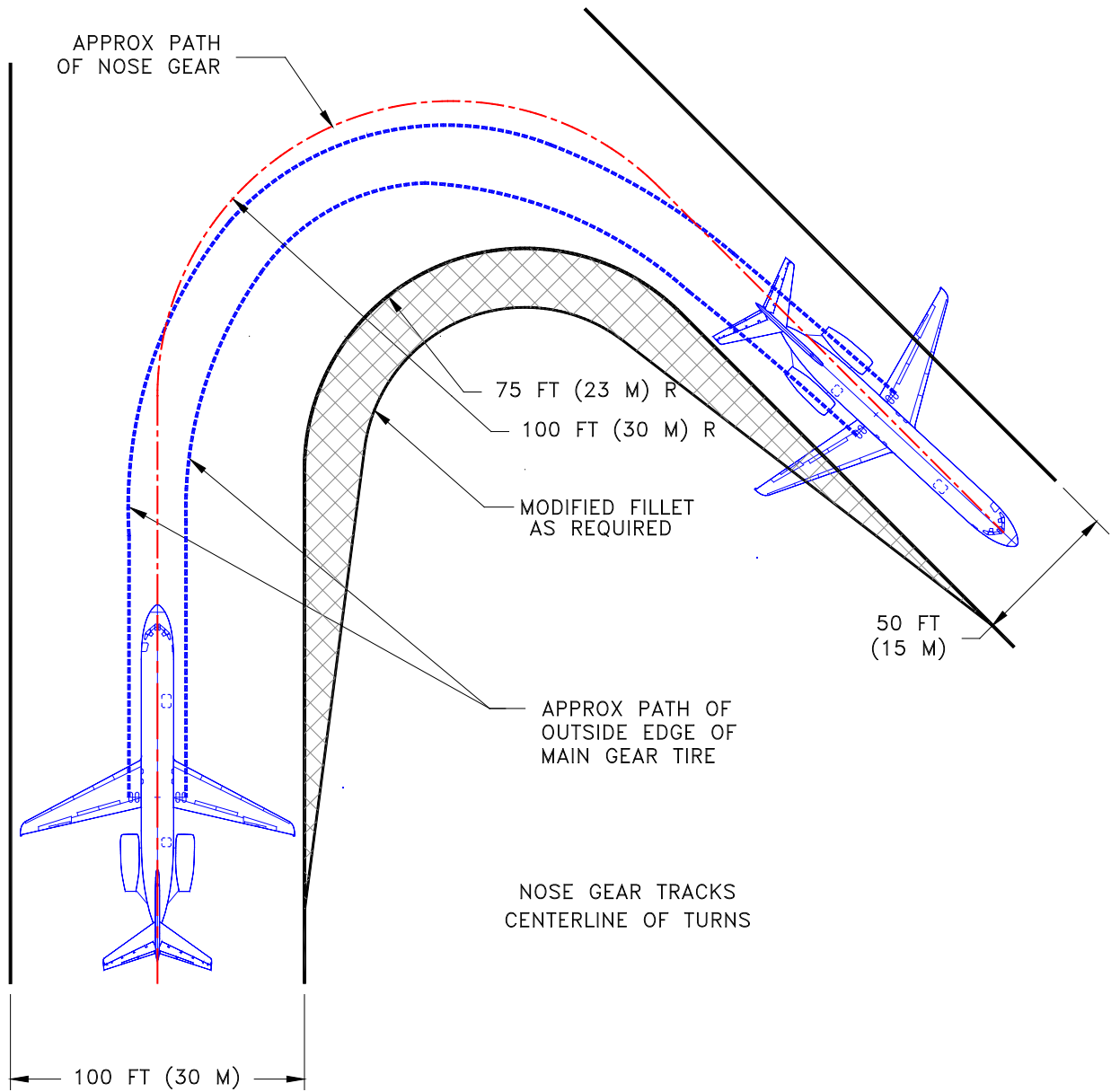

**4.5.1 RUNWAY AND TAXIWAY TURNPATHS, RUNWAY-TO-TAXIWAY,
 MORE THAN 90 DEGREES
 MODEL 717-200**

NOTE:
 BEFORE DETERMINING THE SIZE OF THE
 INTERSECTION FILLET, CHECK WITH THE
 AIRLINES REGARDING THE OPERATING
 PROCEDURES THAT THEY USE AND THE
 TYPES OF AIRCRAFT THAT ARE EXPECTED
 TO SERVE THE AIRPORT.

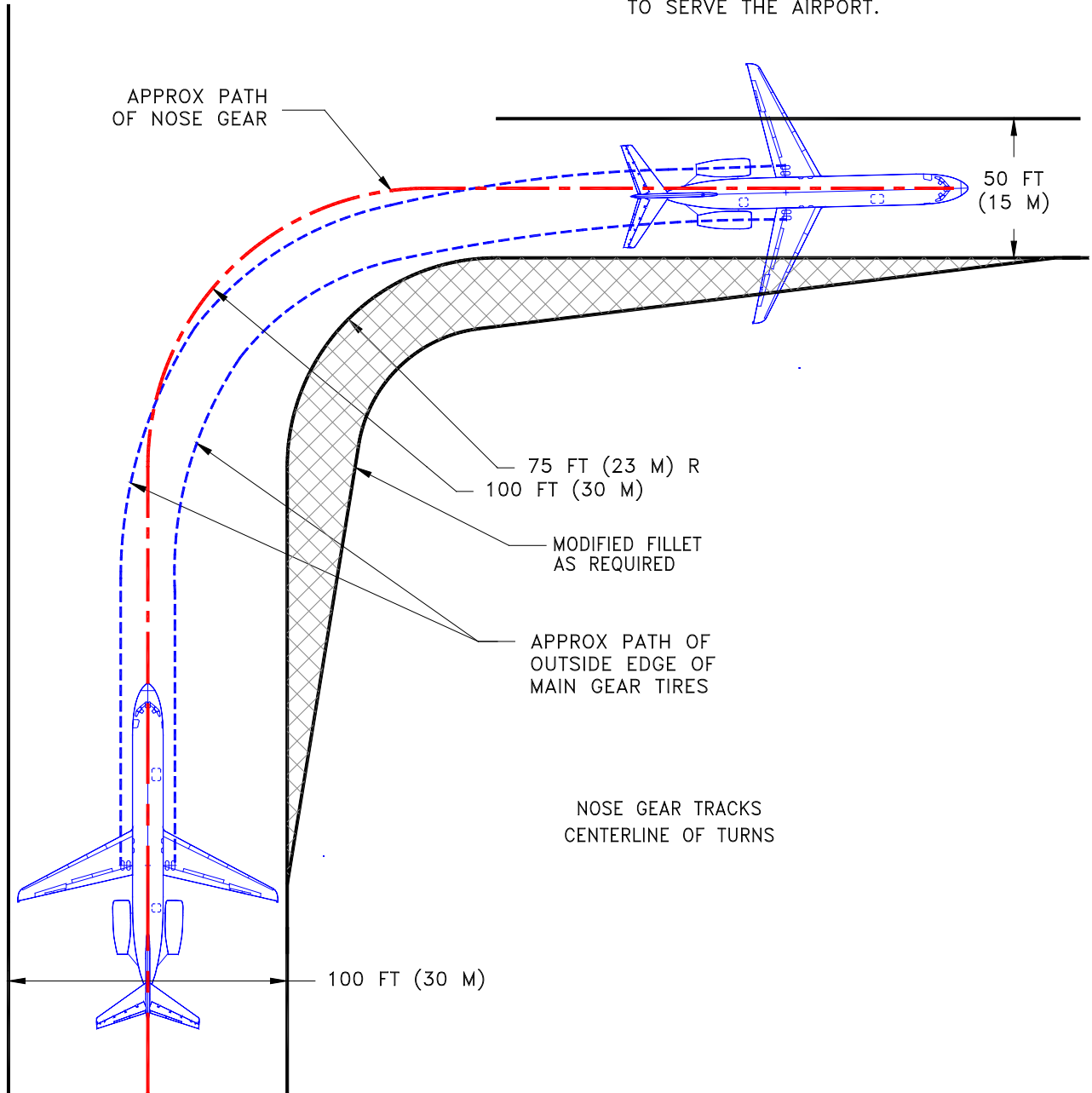

4.5.2 RUNWAY AND TAXIWAY TURNPATHS, RUNWAY-TO-TAXIWAY, 90 DEGREES
MODEL 717-200

D6-58330

NOTE:
 BEFORE DETERMINING THE SIZE OF THE INTERSECTION FILLET, CHECK WITH THE AIRLINES REGARDING THE OPERATING PROCEDURES THAT THEY USE AND THE TYPES OF AIRCRAFT THAT ARE EXPECTED TO SERVE THE AIRPORT.

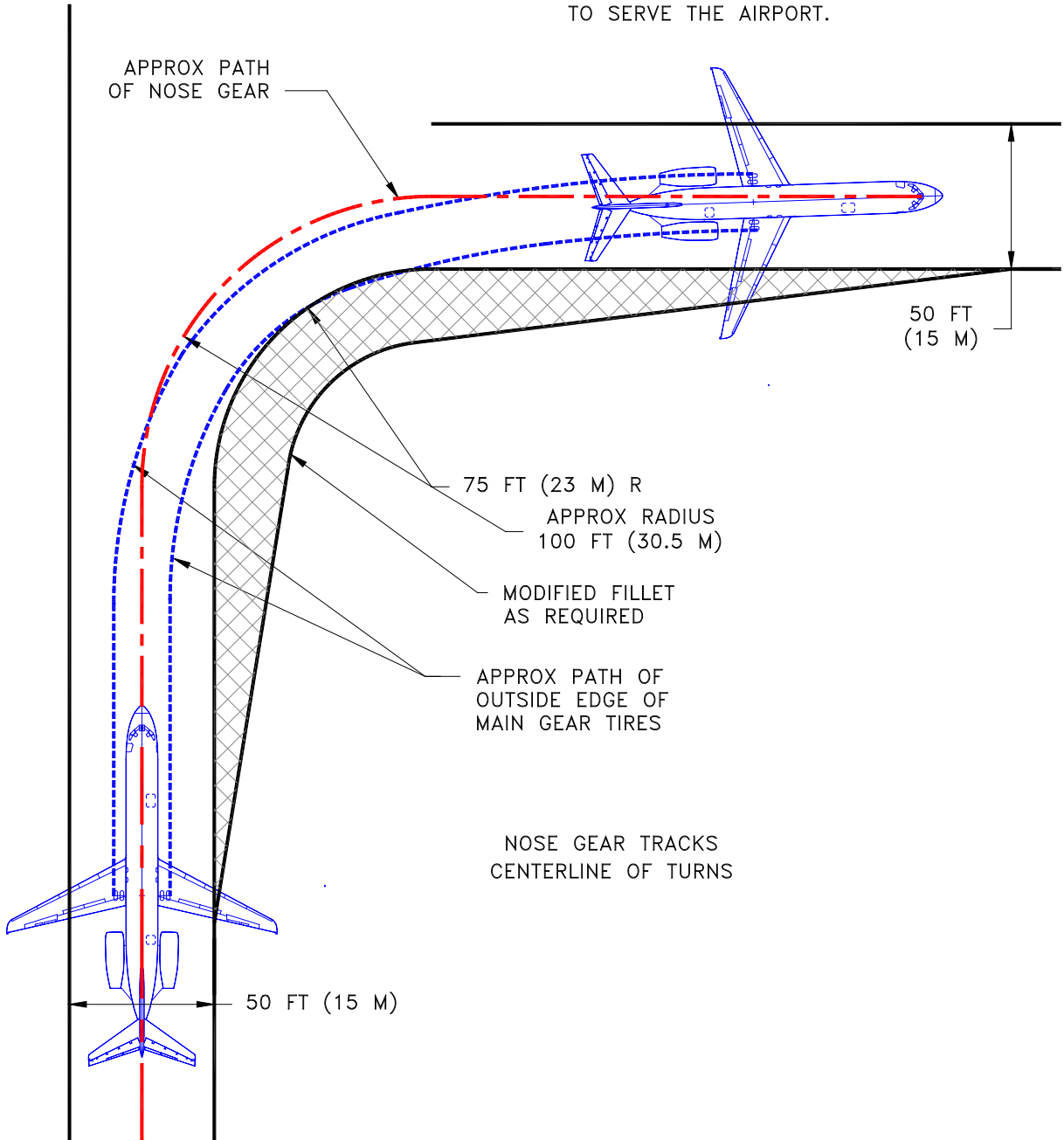

4.5.3 RUNWAY AND TAXIWAY TURNPATHS, TAXIWAY-TO-TAXIWAY, 90 DEGREES, NOSE GEAR TRACKS CENTERLINE
 MODEL 717-200

NOTE:
 BEFORE DETERMINING THE SIZE OF THE
 INTERSECTION FILLET, CHECK WITH THE
 AIRLINES REGARDING THE OPERATING
 PROCEDURES THAT THEY USE AND THE
 TYPES OF AIRCRAFT THAT ARE EXPECTED
 TO SERVE THE AIRPORT.

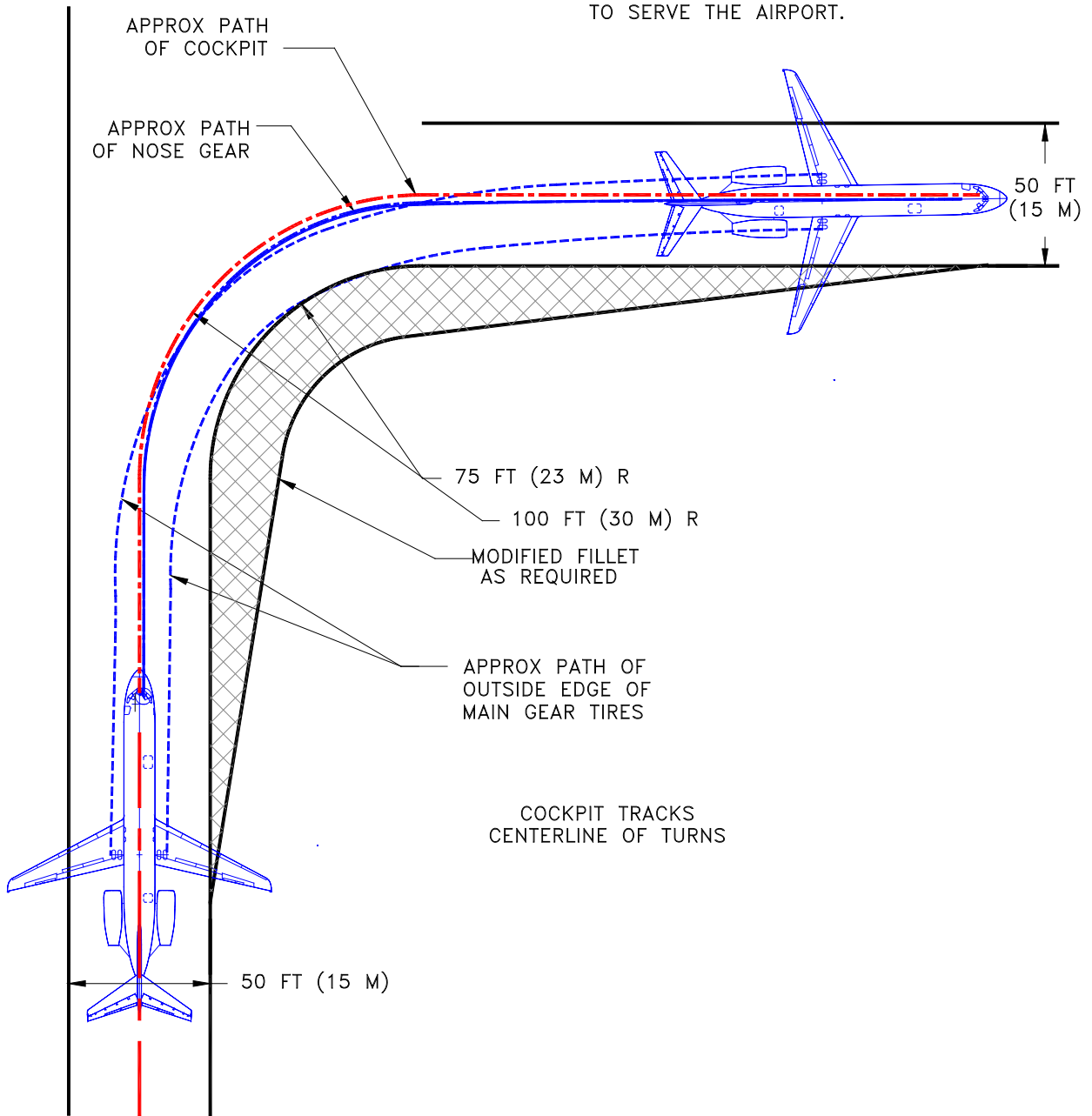

4.5.4 RUNWAY AND TAXIWAY TURNPATHS, TAXIWAY-TO-TAXIWAY, 90 DEGREES, COCKPIT TRACKS CENTERLINE
 MODEL 717-200

D6-58330

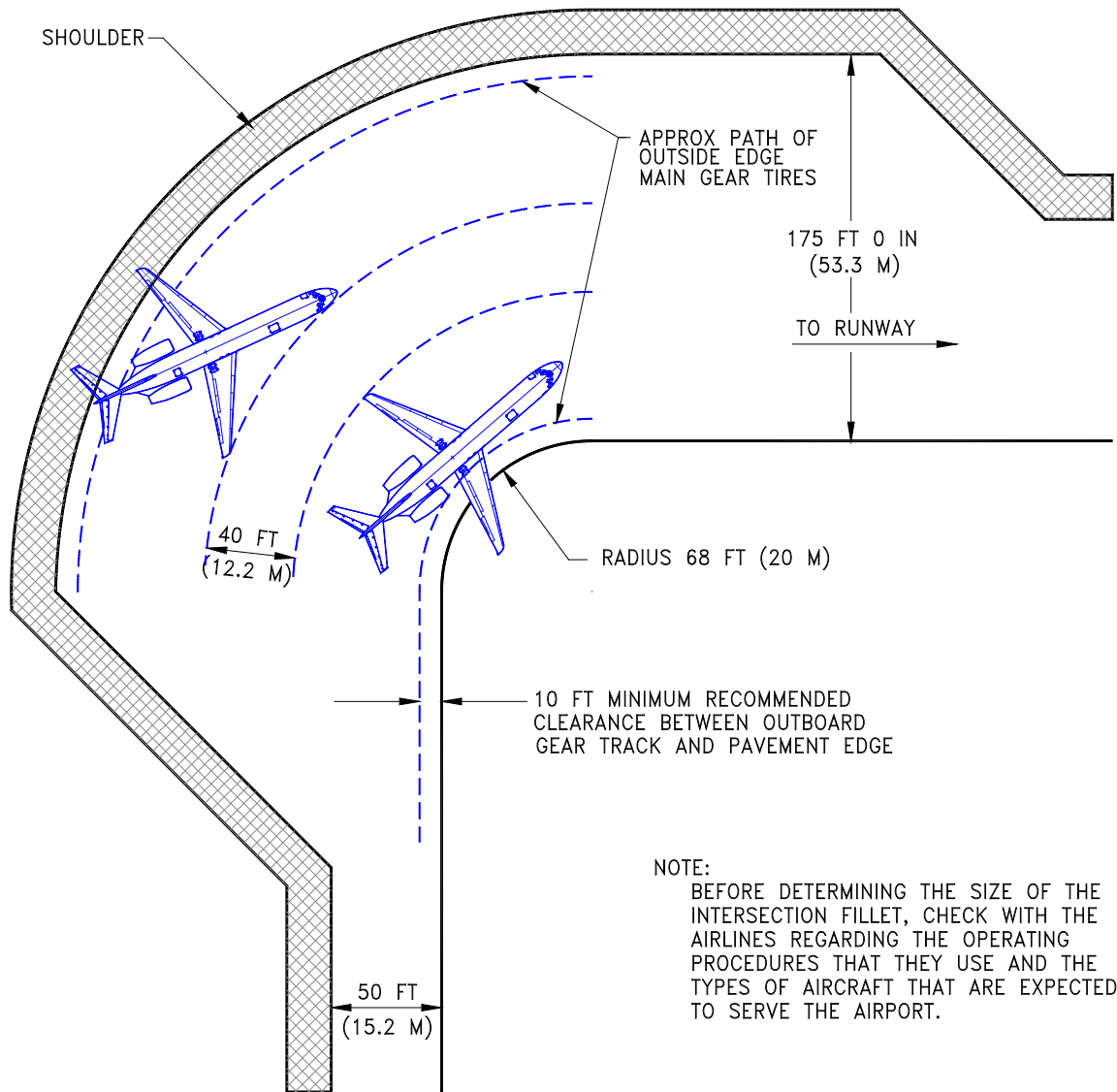

4.6 RUNWAY HOLDING BAY
MODEL 717-200

REV B

D6-58330

NOVEMBER 2014 41

5.0 TERMINAL SERVICING

- 5.1 Airplane Servicing Arrangement (Typical)**
- 5.2 Terminal Operations, Turnaround Station**
- 5.3 Terminal Operations, Enroute Station**
- 5.4 Ground Servicing Connections**
- 5.5 Engine Starting Pneumatic Requirements**
- 5.6 Ground Pneumatic Power Requirements**
- 5.7 Preconditioned Airflow Requirements**
- 5.8 Ground Towing Requirements**

5.0 TERMINAL SERVICING

During turnaround at the terminal, certain services must be performed on the aircraft, usually within a given time, to meet flight schedules. This section shows service vehicle arrangements, schedules, locations of service points, and typical service requirements. The data presented in this section reflect ideal conditions for a single airplane. Service requirements may vary according to airplane condition and airline procedure.

Section 5.1 shows typical arrangements of ground support equipment during turnaround. As noted, if the auxiliary power unit (APU) is used, the electrical, air start, and air-conditioning service vehicles would not be required. Passenger loading bridges or portable passenger stairs could be used to load or unload passengers.

Sections 5.2 and 5.3 show typical service times at the terminal. These charts give typical schedules for performing service on the airplane within a given time. Service times could be rearranged to suit availability of personnel, airplane configuration, and degree of service required.

Section 5.4 shows the locations of ground service connections in graphic and in tabular forms. Typical capacities and service requirements are shown in the tables. Services with requirements that vary with conditions are described in subsequent sections.

Section 5.5 shows typical sea level air pressure and flow requirements for engine start.

Section 5.6 shows air conditioning requirements for heating and cooling (pull-down and pull-up) using ground conditioned air. The curves show airflow requirements to heat or cool the airplane within a given time at ambient conditions.

Section 5.7 shows air conditioning requirements for heating and cooling to maintain a constant cabin air temperature using low pressure conditioned air. This conditioned air is supplied through an 8-in ground air connection (GAC) directly to the passenger cabin, bypassing the air cycle machines.

Section 5.8 shows ground towing requirements for various ground surface conditions.

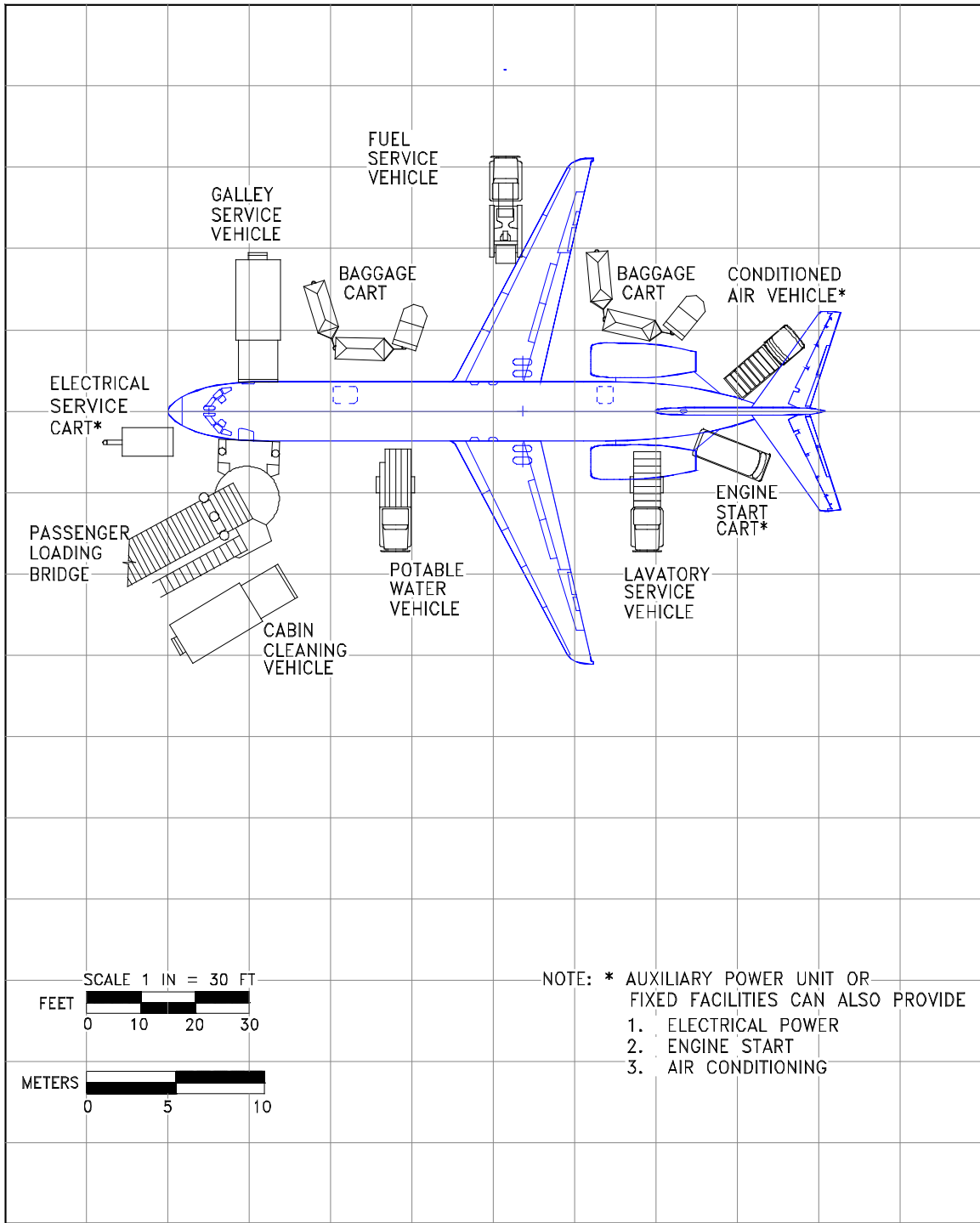

5.1 AIRPLANE SERVICING ARRANGEMENT (TYPICAL)
MODEL 717-200

D6-58330

44 NOVEMBER 2014

REV B

THIS DATA IS PROVIDED TO ILLUSTRATE THE GENERAL SCOPE AND TYPES OF TASKS INVOLVED IN TERMINAL OPERATIONS. VARYING AIRLINE PRACTICES AND OPERATING CIRCUMSTANCES THROUGHOUT THE WORLD WILL RESULT IN DIFFERENT SEQUENCES AND TIME INTERVALS TO ACCOMPLISH THE TASKS SHOWN.

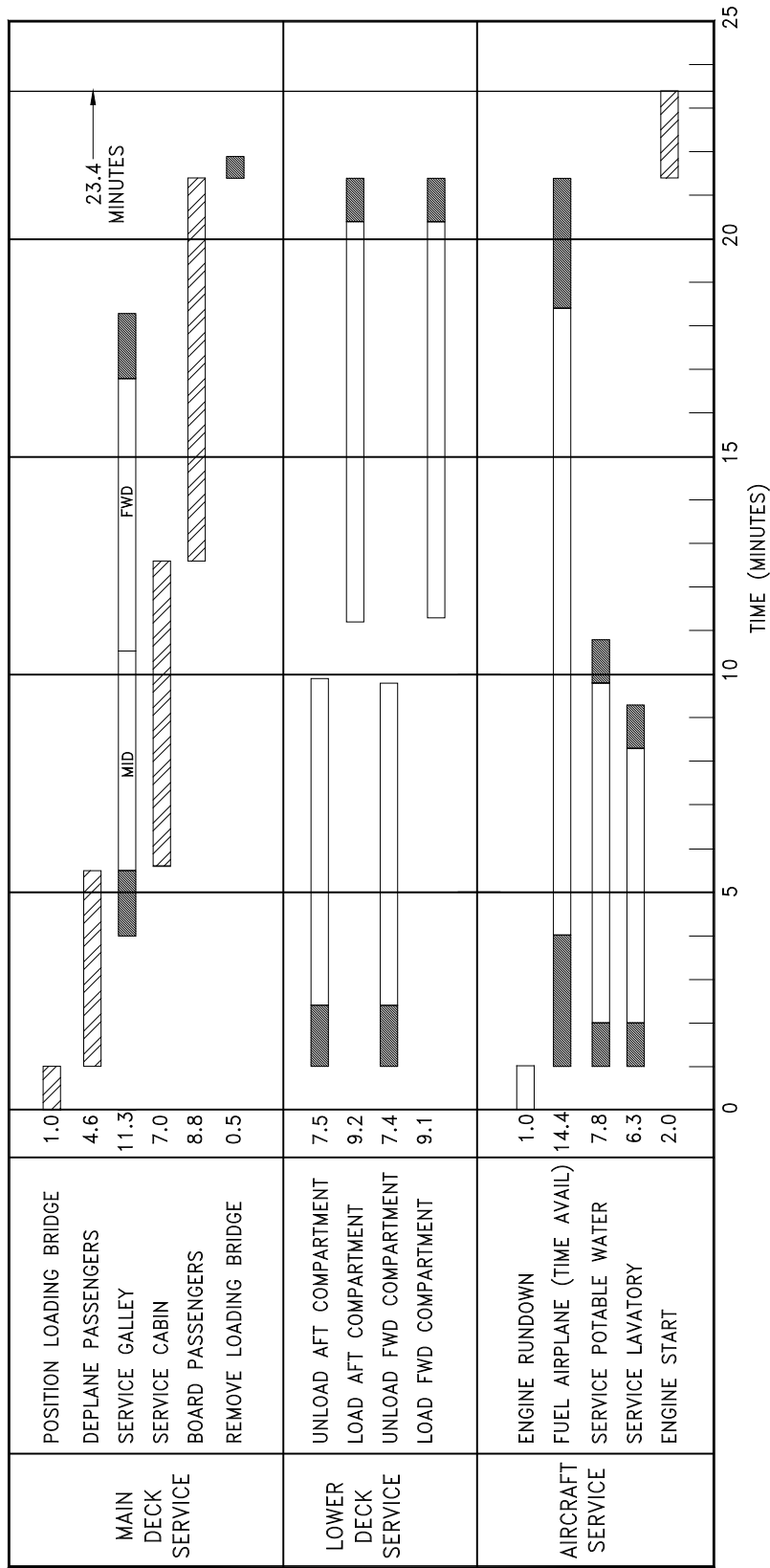

NOTES:

1. [Diagonal lines] INDICATES CRITICAL TIMEPATH
2. [Solid black] INDICATES VEHICLE POSITIONING/REMOVAL
3. 106 PASSENGERS - MIXED CLASS CONFIGURATION
4. 100% LOAD FACTOR
5. SINGLE BRIDGE LOADING
6. 1.2 BAGS CHECKED PER PASSENGER
7. 1000 POUNDS OF CARGO
8. DEPLANING AND ENPLANING RATES ARE BASED ON ONE CARRY-ON ITEM PER PASSENGER

5.2 TERMINAL OPERATIONS, TURNAROUND STATION
MODEL 717-200

D6-58330

THIS DATA IS PROVIDED TO ILLUSTRATE THE GENERAL SCOPE AND TYPES OF TASKS INVOLVED IN TERMINAL OPERATIONS. VARYING AIRLINE PRACTICES AND OPERATING CIRCUMSTANCES THROUGHOUT THE WORLD WILL RESULT IN DIFFERENT SEQUENCES AND TIME INTERVALS TO ACCOMPLISH THE TASKS SHOWN.

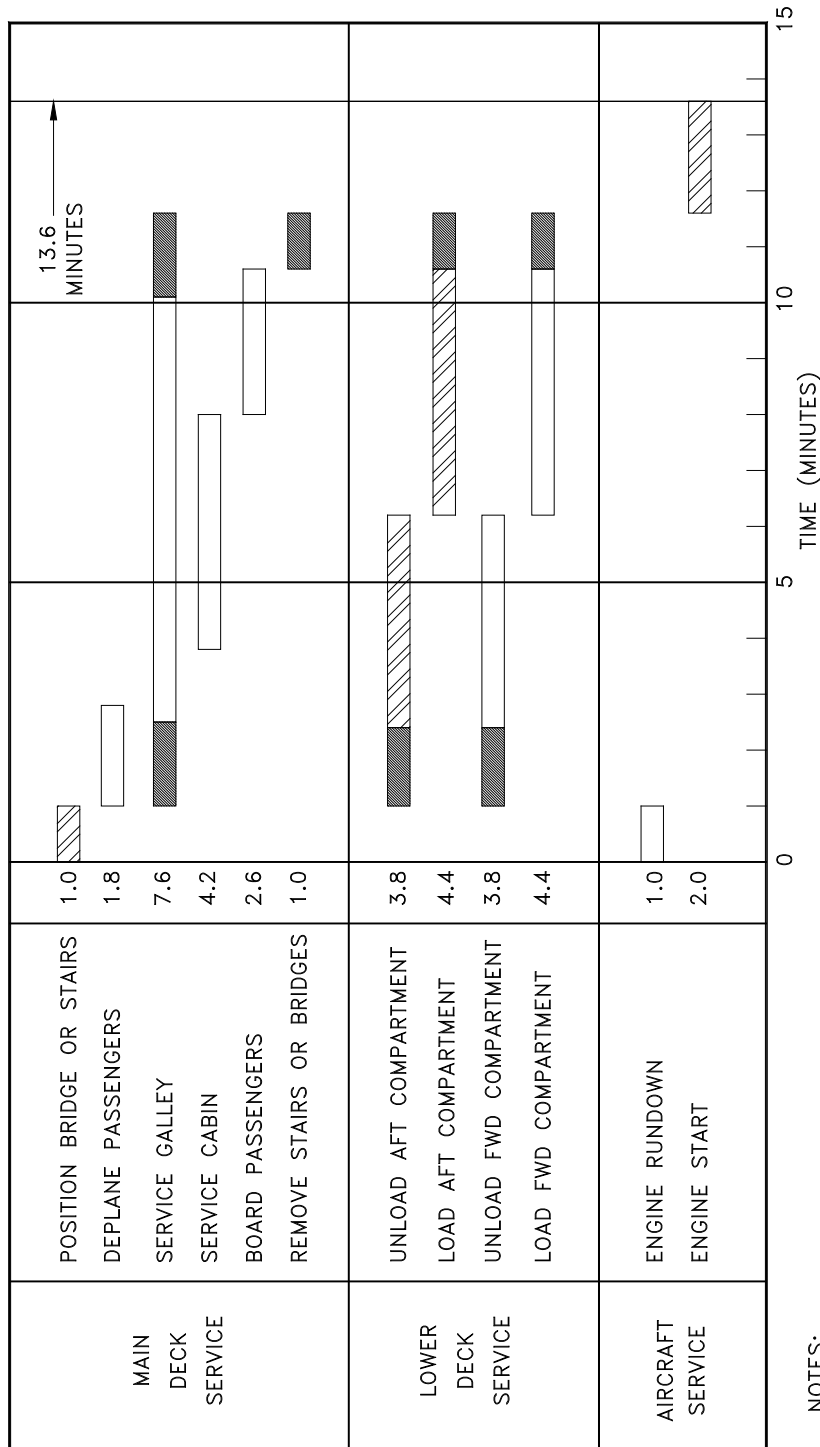

NOTES:

1. [Diagonal lines] INDICATES CRITICAL TIMEPATH
2. [Solid black] INDICATES VEHICLE POSITIONING/REMOVAL
3. 106 PASSENGERS – MIXED CLASS CONFIGURATION
4. 100% LOAD FACTOR/55% EXCHANGE
5. BRIDGE OR AIRSTAIR LOADING

5.3 TERMINAL OPERATIONS, ENROUTE STATION
MODEL 717-200

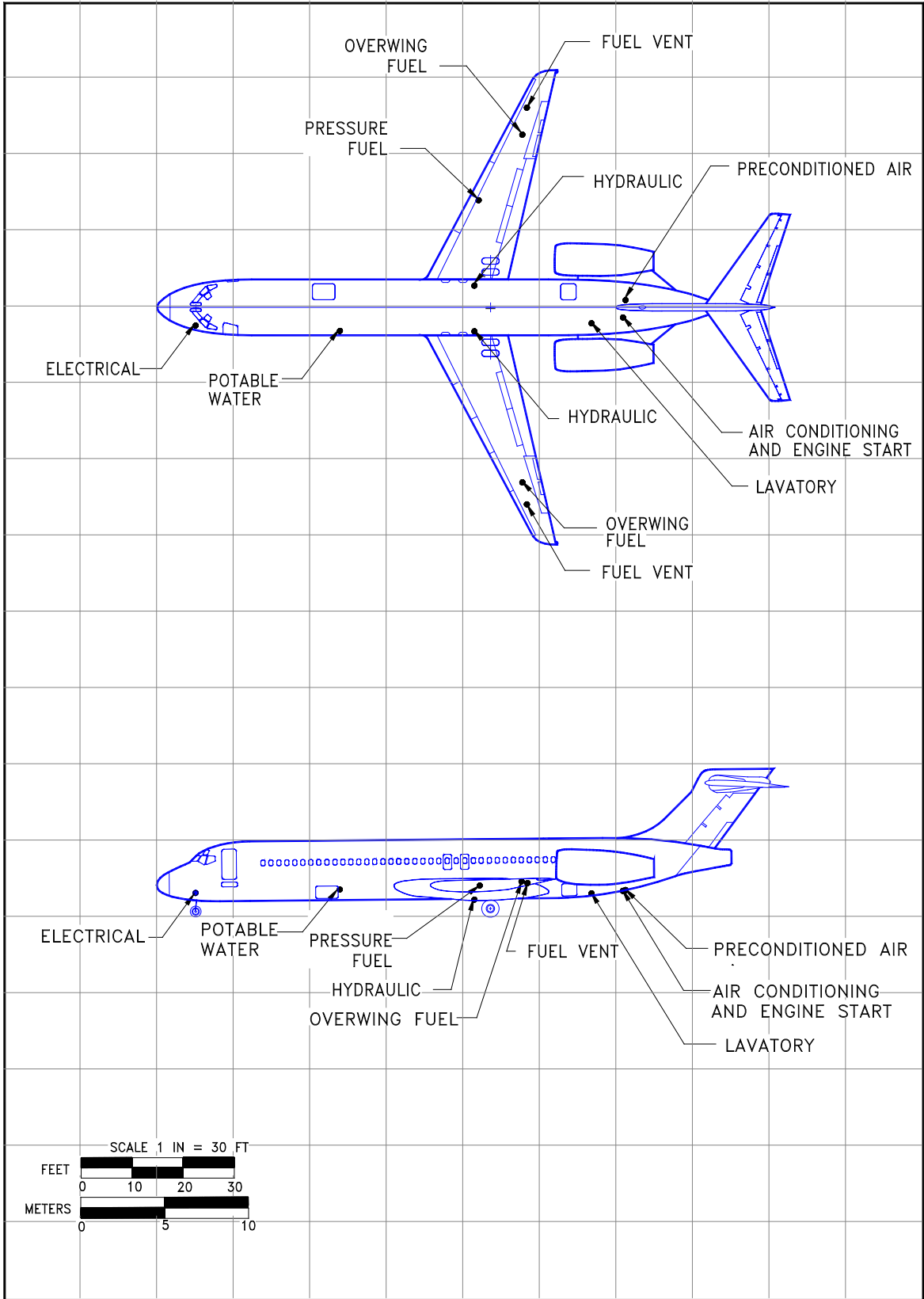

5.4.1 GROUND SERVICING CONNECTIONS
MODEL 717-200

D6-58330

REV B

NOVEMBER 2014 47

SYSTEM	DISTANCE AFT OF NOSE		DISTANCE FROM AIRPLANE CENTERLINE				MAX HT ABOVE GROUND	
	FT - IN	M	LH SIDE		RH SIDE		FT - IN	M
			FT - IN	M	FT - IN	M		
CONDITIONED AIR ONE 8-IN (20.3 CM) PORT	91-10	28.0	-	-	1-8	0.5	5-8	1.7
ELECTRICAL ONE CONNECTIONS 60 KVA, 200/115 V AC 400 HZ, 3-PHASE EACH	7-5	2.3	3-4	1.0	-	-	5-1	1.6
FUEL ONE UNDERWING PRESSURE CONNECTOR ON RIGHT WING TOTAL TANK CAPACITY: 3,673 US GAL (13,900 LITERS) MAX FUEL RATE: 420 GPM (1,590 LPM) MAX FILL PRESSURE: 50 PSIG (3.52 KG/CM ²)	63-0	19.2	-	-	21-4	6.5	6-3	1.9
TWO GRAVITY FEED FILLER INLETS	71-7	21.8	34-3	10.4	34-3	10.4	7-2	1.1
TWO FUEL VENTS	72-7	22.1	39-0	11.9	39-0	11.9	7-6	2.3
HYDRAULIC TWO SERVICE PANELS	62-2	18.9	4-6	1.4	4-6	1.4	3-9	1.1
LAVATORY ONE SERVICE CONNECTION	85-2	26.0	2-11	0.9	-	-	5-0	1.5
PNEUMATIC ONE 3-IN (7.6-CM) PORT	91-4	27.8	1-9	0.5	-	-	5-8	1.7
POTABLE WATER ONE SERVICE CONNECTION	35-9	10.9	4-5	1.3	-	-	5-9	1.8

5.4.2 GROUND SERVICING CONNECTIONS AND CAPACITIES

MODEL 717-200

D6-58330

48 NOVEMBER 2014

REV B

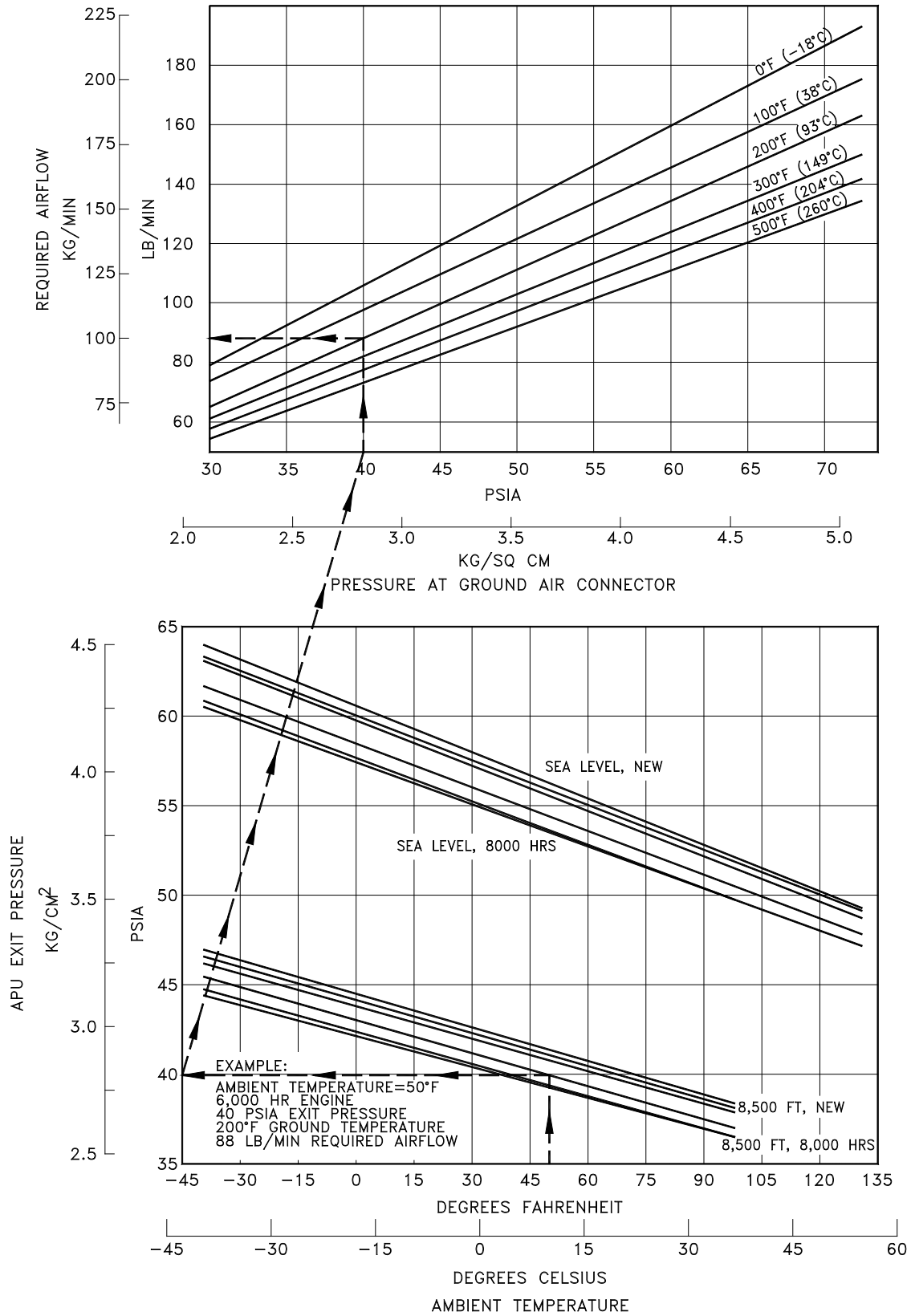

5.5 ENGINE STARTING PNEUMATIC REQUIREMENTS
 MODEL 717-200

D6-58330

REV B

NOVEMBER 2014 49

NOTES:

INITIAL CABIN TEMPERATURE AT 0° F (-17.8° C)
 OUTSIDE AIR TEMPERATURE AT 0° F (-17.8° C)
 NO GALLEY LOAD, CLOUDY DAY, NO LIGHTS
 PRESSURE = 12 TO 70 PSIG AT THE GROUND CONNECTION
 TEMPERATURE AT GROUND CONNECTION IS 300° F (148.9° C).

OPERATIONAL NOTES:

- 1) PACK FLOW SWITCH IN "HIGH" FLOW POSITION
- 2) TEMP SELECTORS IN "AUTO" MODE POSITION

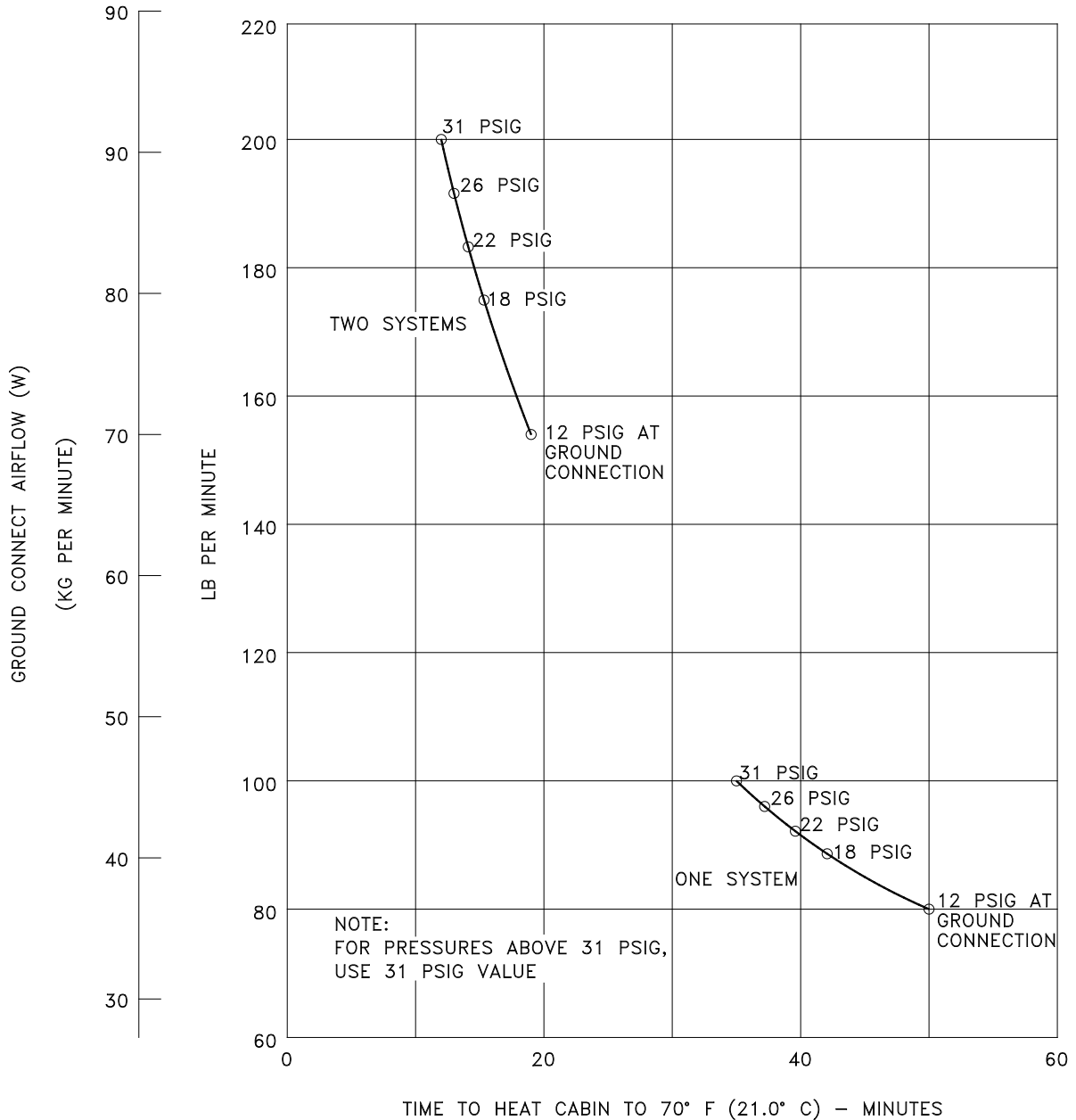

5.6.1 GROUND PNEUMATIC POWER REQUIREMENTS – CABIN HEATING

MODEL 717-200

D6-58330

50 NOVEMBER 2014

REV B

NOTES:

INITIAL CABIN TEMPERATURE AT 108° F (42.2° C)
 OUTSIDE AIR TEMPERATURE AT 103° F (39.4° C)
 SOLAR LOAD 1775 BTU/HR, BRIGHT DAY, SOLAR IRRADIATION
 NO GALLEY LOAD, DAY LIGHTING ON, NO PASSENGERS
 PRESSURE = 12 TO 70 PSIG AT THE GROUND CONNECTION
 TEMPERATURE AT GROUND CONNECTION IS 410° F (210° C).

OPERATIONAL NOTES:

- 1) PACK FLOW SWITCH IN "HIGH" FLOW POSITION
- 2) TEMP SELECTORS IN "AUTO" MODE POSITION

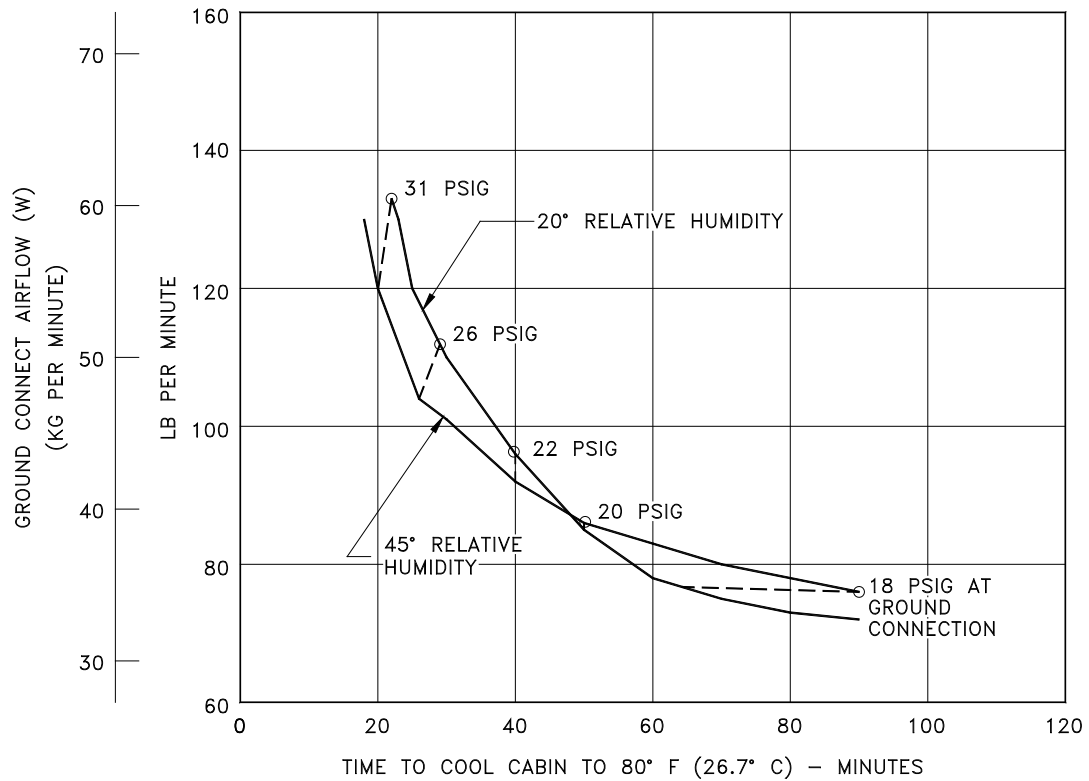

5.6.2 GROUND PNEUMATIC POWER REQUIREMENTS – CABIN COOLING
 MODEL 717-200

D6-58330

REV B

NOVEMBER 2014 51

NOTES:

- ① - CABIN AT 75°F(24°C), 4 CREW, 106 PASSENGERS, NO GALLEY LOAD, BRIGHT DAY, SOLAR IRRADIATION, SOLAR LOAD 1775 BTU/HR, ELECTRICAL LOAD 3250 BTU/HR.
- ② - CABIN AT 80°F(26.7°C), 4 CREW, 106 PASSENGERS, NO GALLEY LOAD, BRIGHT DAY, SOLAR IRRADIATION, SOLAR LOAD 1775 BTU/HR, ELECTRICAL LOAD 3250 BTU/HR.
- ③ - CABIN AT 75°F(24°C), 3 CREW ONLY, BRIGHT DAY, SOLAR IRRADIATION, SOLAR LOAD 1775 BTU/HR, ELECTRICAL LOAD 3250 BTU/HR, GALLEY LOAD 3000 BTU/HR.
- ④⑤⑥ - CABIN AT 70°F(21°C), NO CREW, NO PASSENGERS, CLOUDY DAY OR NIGHT, NO SOLAR IRRADIATION, NO ELECTRICAL LOAD, NO GALLEY LOAD.

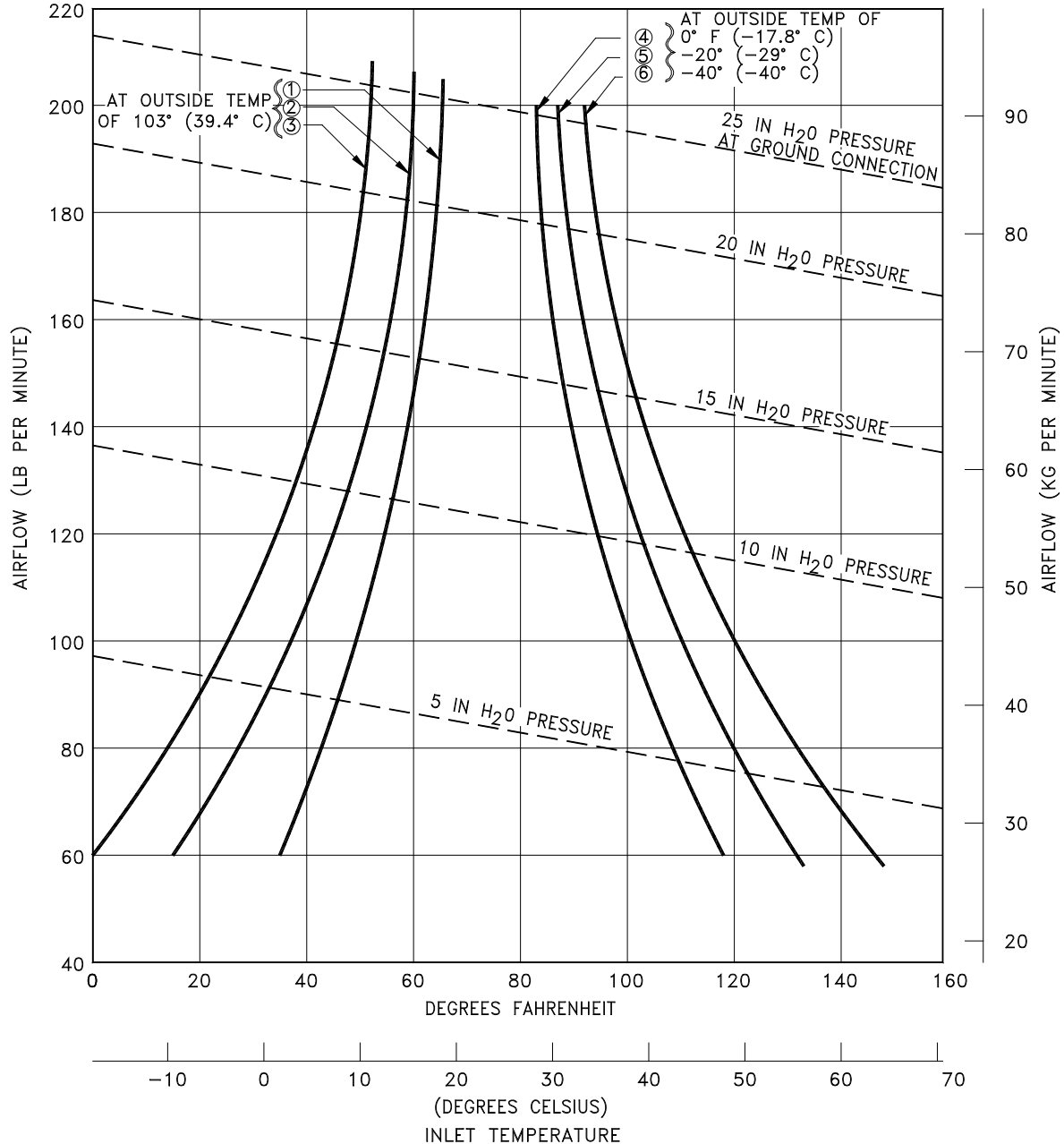

5.7 PRECONDITIONED AIRFLOW REQUIREMENTS
MODEL 717-200

D6-58330

52 NOVEMBER 2014

REV B

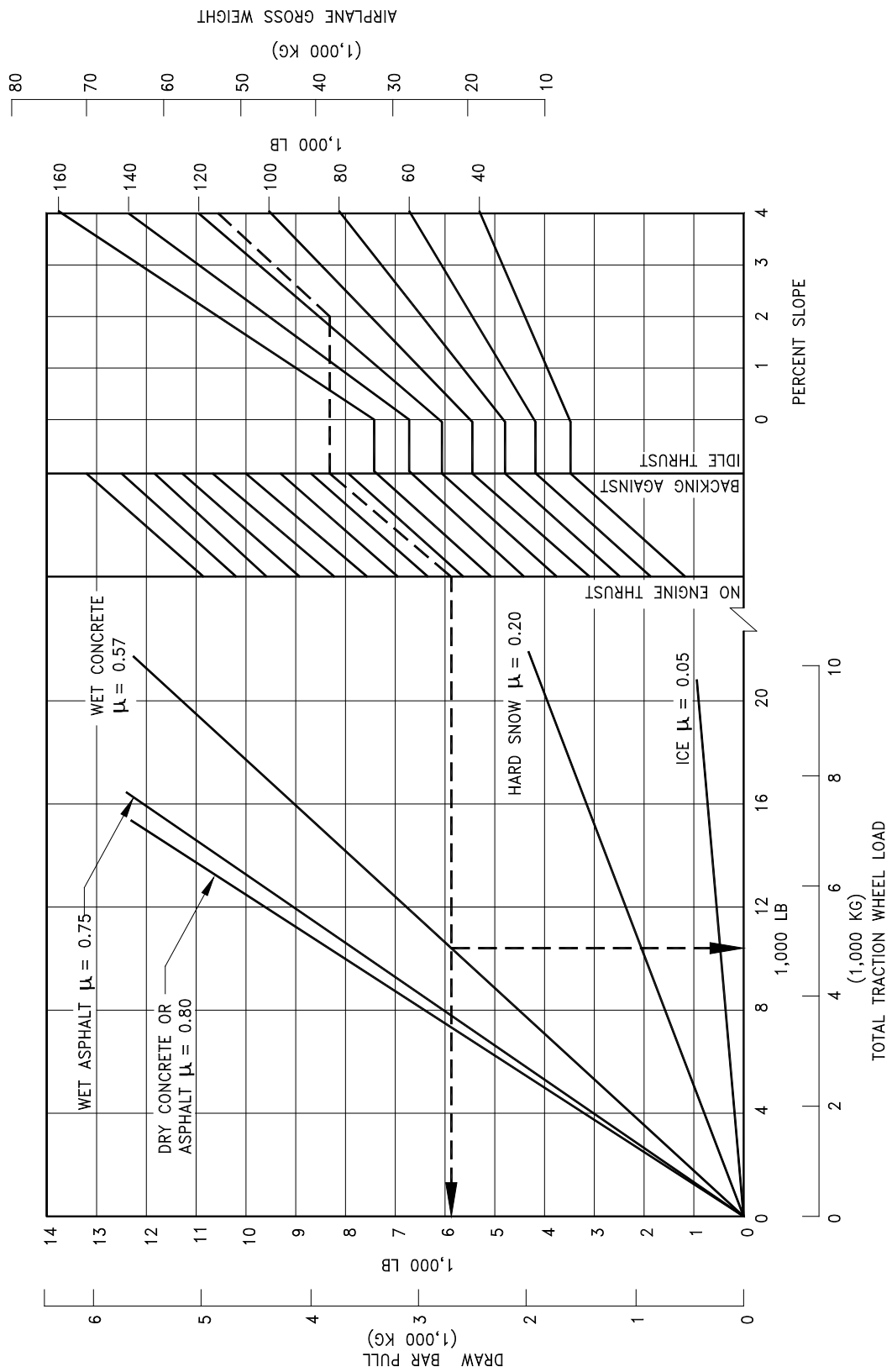

5.8 GROUND TOWING REQUIREMENTS
MODEL 717-200

D6-58330

REV B

NOVEMBER 2014 53

6.0 JET ENGINE WAKE AND NOISE DATA

6.1 Jet Engine Exhaust Velocities and Temperatures

6.2 Airport and Community Noise

6.0 JET ENGINE WAKE AND NOISE DATA

6.1 Jet Engine Exhaust Velocities and Temperature

This section shows exhaust velocity and temperature contours aft of the 717-200. The contours were calculated from a standard computer analysis using three-dimensional viscous flow equations with mixing of primary, fan, and free-stream flow. The presence of the ground plane is included in the calculations as well as engine tilt and toe-in. Mixing of flows from the engines is also calculated. The analysis does not include thermal buoyancy effects, which tend to elevate the jet wake above the ground plane. The buoyancy effects are considered to be small relative to the lateral velocity and therefore are not included.

The graphs show jet wake velocity and temperature contours for a representative engine. The results are valid for sea level, static, standard day conditions. The effect of wind on jet wakes was not included. There is evidence to show that a downwind or an upwind component does not simply add or subtract from the jet wake velocity, but rather carries the whole envelope in the direction of the wind. Crosswinds may carry the jet wake contour far to the side at large distances behind the airplane.

It should be understood, these exhaust velocity contours reflect steady-state, at maximum taxi weight, and not transient-state exhaust velocities. A steady-state is achieved with the aircraft in a fixed location, engine running at a given thrust level and measured when the contours stop expanding and stabilize in size, which could take several seconds. The steady-state condition, therefore, is conservative. Contours shown also do not account for performance variables such as ambient temperature or field elevation. For the terminal area environment, the transient-state is a more accurate representation of the actual exhaust contours when the aircraft is in motion and encountering static air with forward or turning movement, but it is very difficult to model on a consistent basis due to aircraft weight, weather conditions, the high degree of variability in terminal and apron configurations, and intensive numerical calculations. If the contours presented here are overly restrictive for terminal operations, The Boeing Company recommends conducting an analysis of the actual exhaust contours experienced by the using aircraft at the airport.

NOTES:

- * ENGINE THRUST AT IDLE SETTING
- * CONTOURS CALCULATED FROM COMPUTER DATA
- * STANDARD DAY
- * SEA LEVEL
- * NO WIND
- * BOTH ENGINES RUNNING
- * 840 LBF/ENGINE

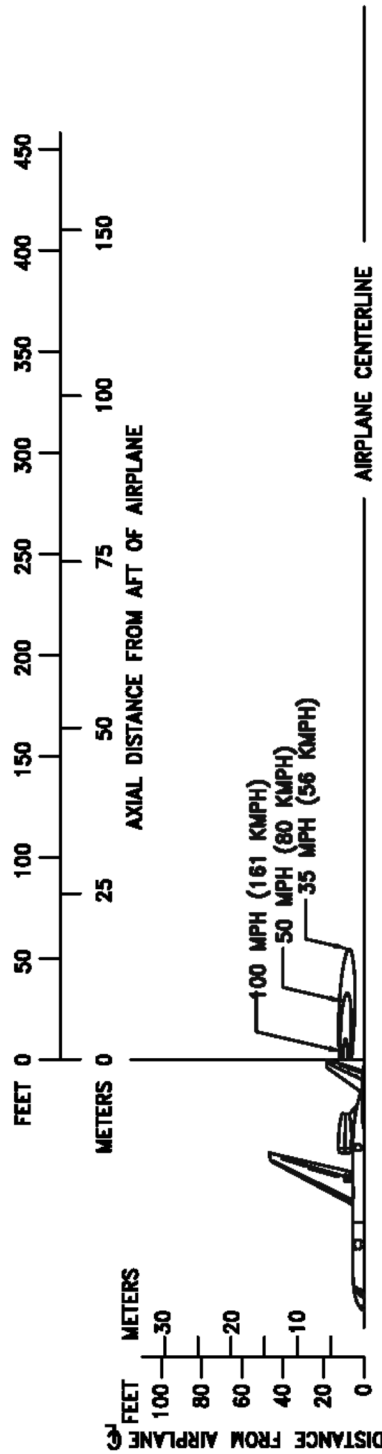
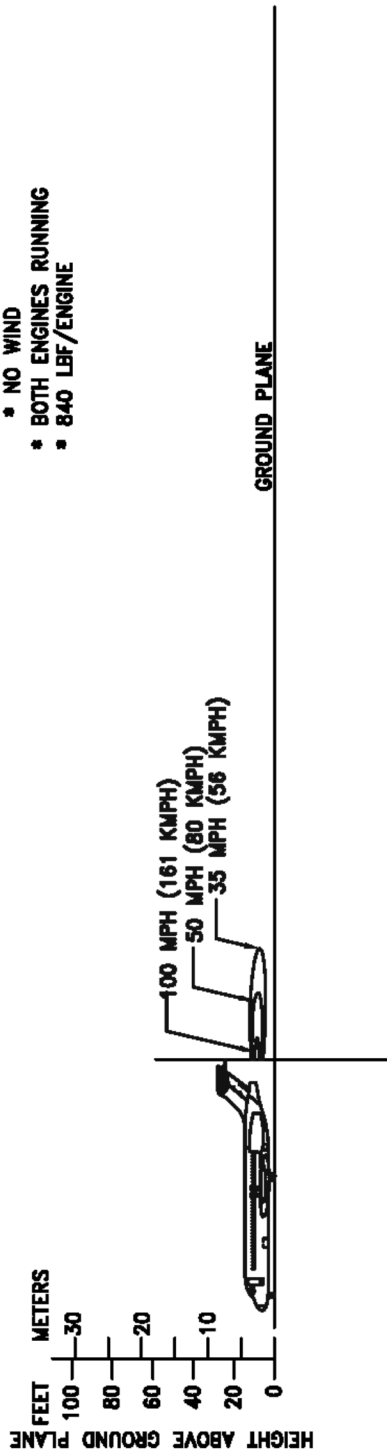

6.1.1 JET ENGINE EXHAUST VELOCITY CONTOURS - IDLE THRUST – BOTH ENGINES
MODEL 717-200

- NOTES:**
- * ENGINE THRUST AT BREAKAWAY SETTING
 - * CONTOURS CALCULATED FROM COMPUTER DATA
 - * STANDARD DAY
 - * SEA LEVEL
 - * NO WIND
 - * BOTH ENGINES RUNNING
 - * 2,500 LBF/ENGINE

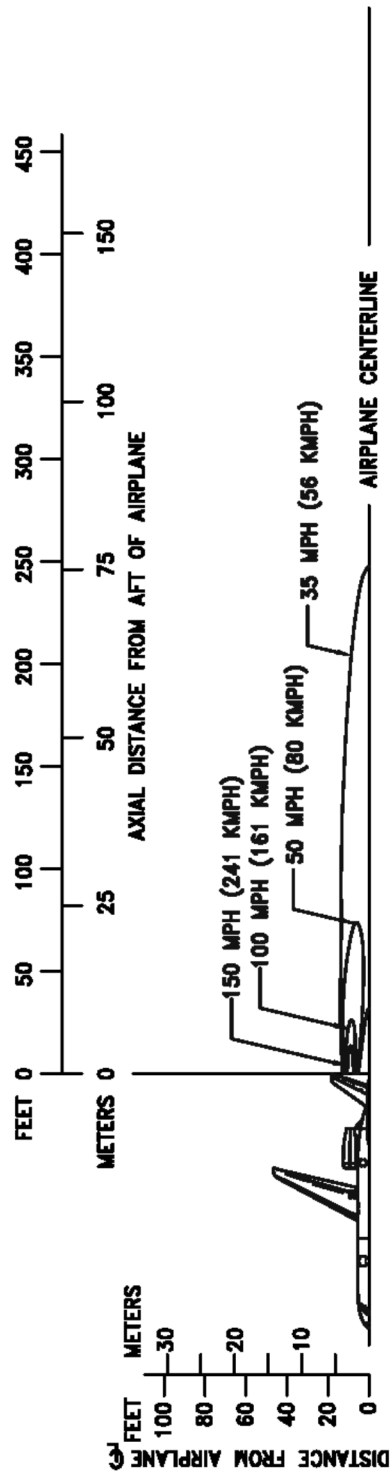
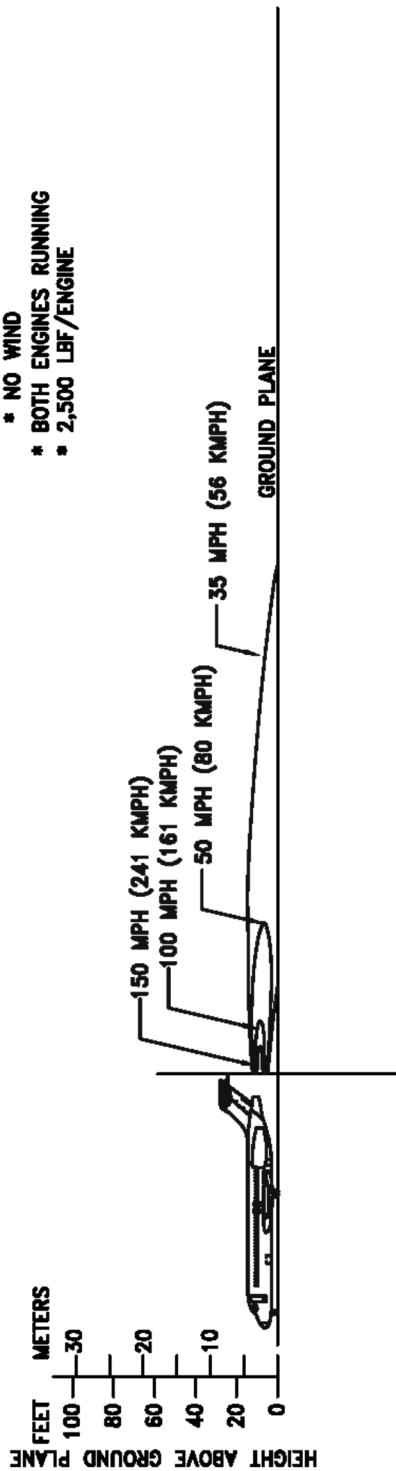

6.1.2 JET ENGINE EXHAUST VELOCITY CONTOURS - BREAKAWAY THRUST – BOTH ENGINES
 MODEL 717-200

NOTES:

- * ENGINE THRUST AT BREAKAWAY SETTING
- * CONTOURS CALCULATED FROM COMPUTER DATA
- * STANDARD DAY
- * SEA LEVEL
- * NO WIND
- * 0% SLOPE
- * SINGLE ENGINE RUNNING
- * 4,880 LBF/ENGINE (MTW=122,000 LBS)

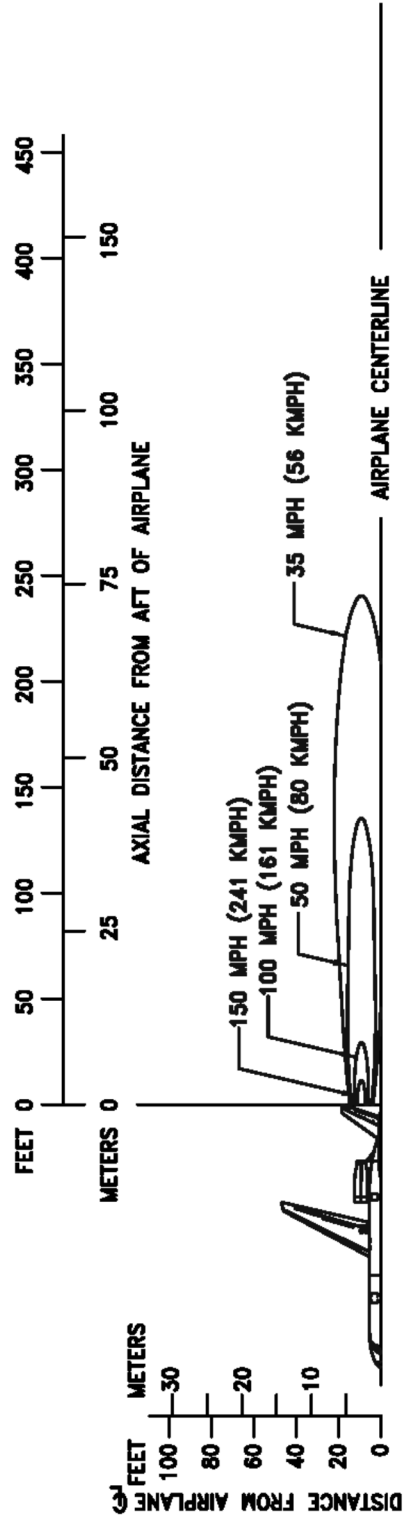
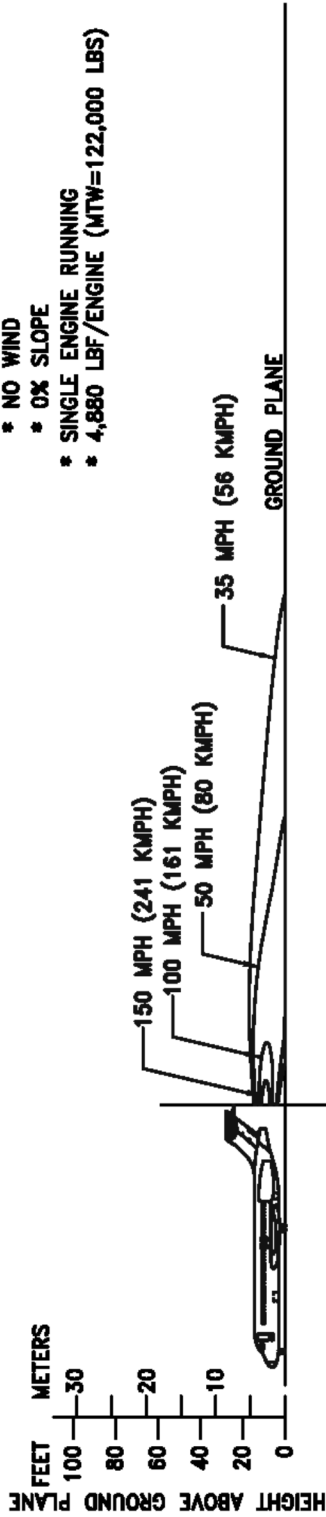

6.1.3 JET ENGINE EXHAUST VELOCITY CONTOURS - BREAKAWAY THRUST – SINGLE ENGINE - MTW MODEL 717-200

- NOTES:
- * ENGINE THRUST AT BREAKAWAY SETTING
 - * CONTOURS CALCULATED FROM COMPUTER DATA
 - * STANDARD DAY
 - * SEA LEVEL
 - * NO WIND
 - * 0% SLOPE
 - * SINGLE ENGINE RUNNING
 - * 4,400 LBF/ENGINE (MLW=110,000 LBS)

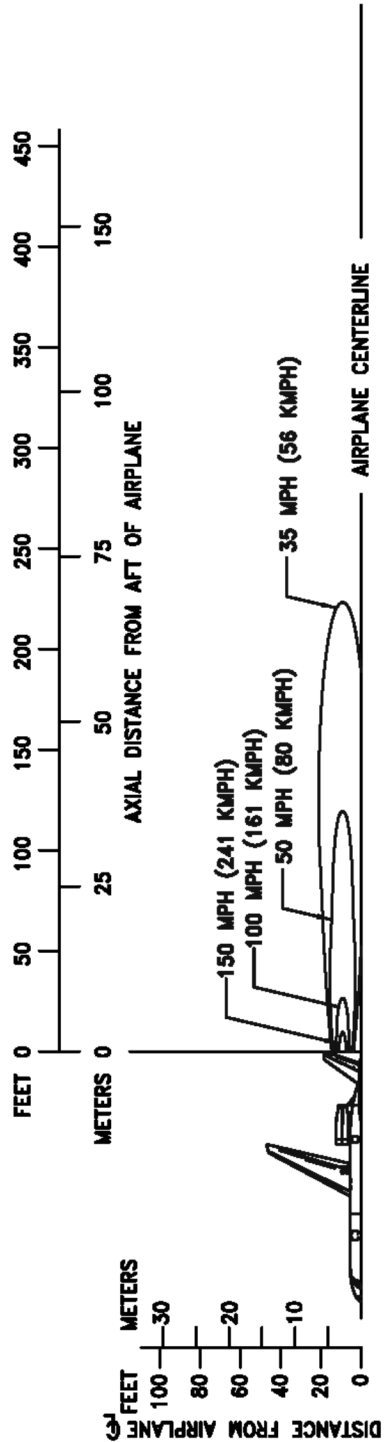
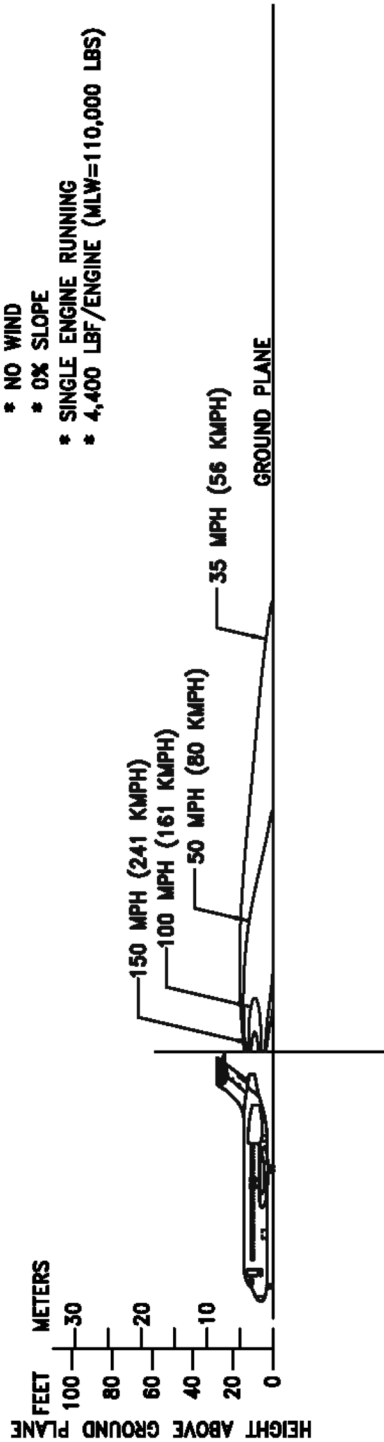

6.1.4 JET ENGINE EXHAUST VELOCITY CONTOURS - BREAKAWAY THRUST – SINGLE ENGINE - MLW
MODEL 717-200

- NOTES:
- * ENGINE THRUST AT TAKEOFF SETTING
 - * CONTOURS CALCULATED FROM COMPUTER DATA
 - * STANDARD DAY
 - * SEA LEVEL
 - * NO WIND
 - * BOTH ENGINES RUNNING
 - * 21,070 LBF/ENGINE

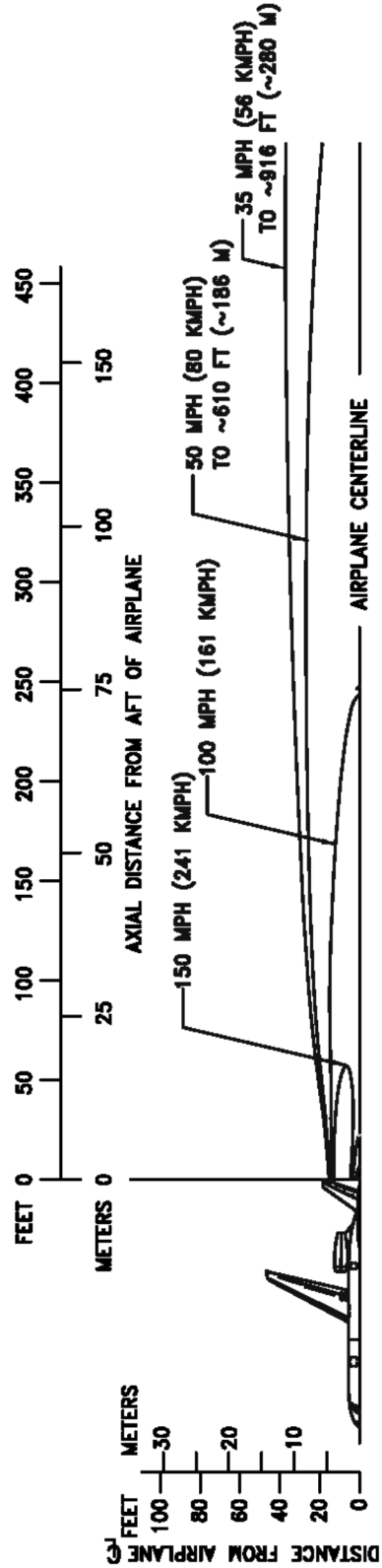
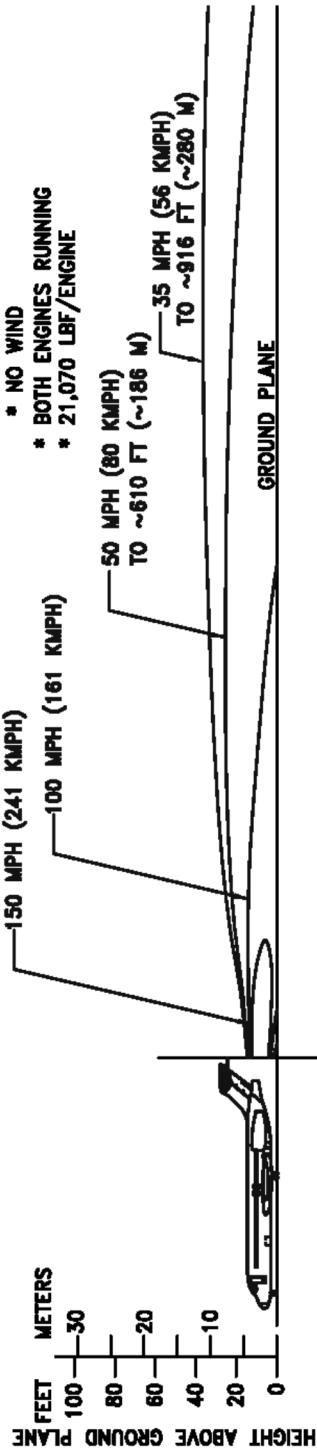

6.1.5 JET ENGINE EXHAUST VELOCITY CONTOURS - TAKEOFF THRUST – BOTH ENGINES
MODEL 717-200

- NOTES:**
- * ENGINE THRUST AT IDLE SETTING
 - * CONTOURS CALCULATED FROM COMPUTER DATA
 - * STANDARD DAY
 - * SEA LEVEL
 - * NO WIND
 - * BOTH ENGINES RUNNING
 - * 840 LBF/ENGINE

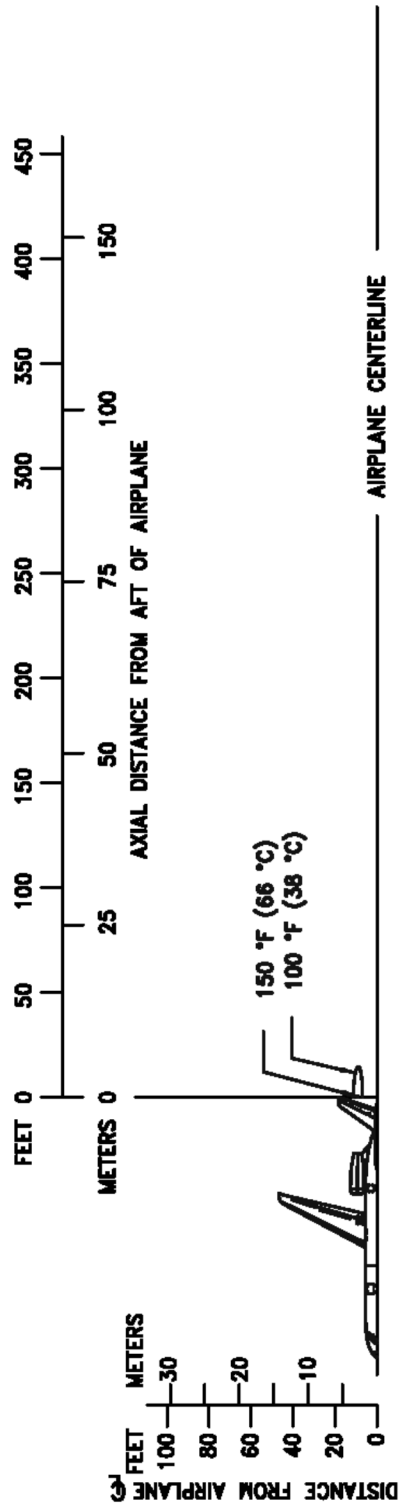
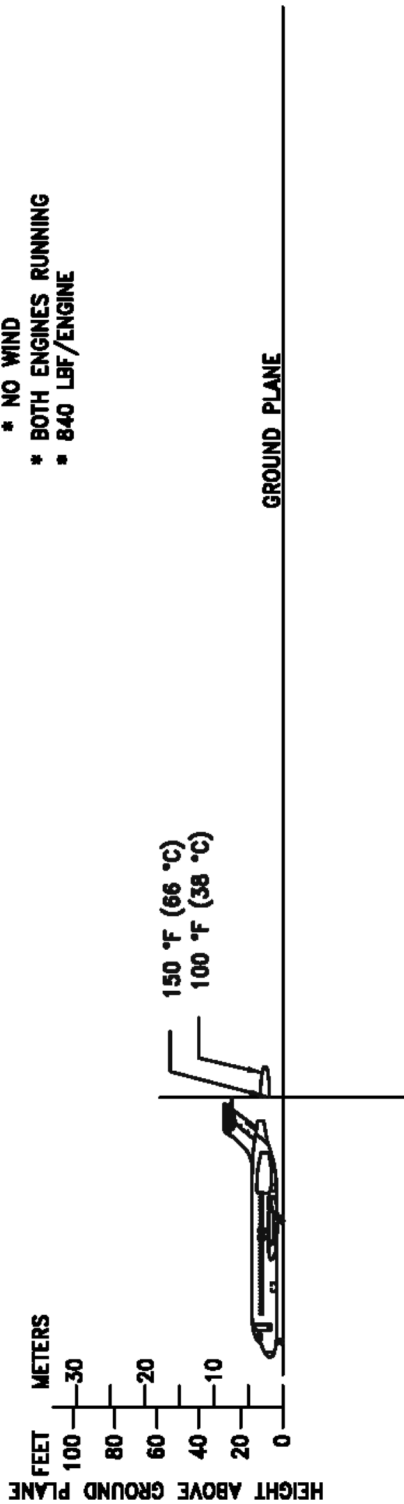

**6.1.6 JET ENGINE EXHAUST TEMPERATURE CONTOURS - IDLE THRUST – BOTH ENGINES
MODEL 717-200**

- NOTES:**
- * ENGINE THRUST AT BREAKAWAY SETTING
 - * CONTOURS CALCULATED FROM COMPUTER DATA
 - * STANDARD DAY
 - * SEA LEVEL
 - * NO WIND
 - * SINGLE ENGINE RUNNING
 - * 2,500 LBF/ENGINE

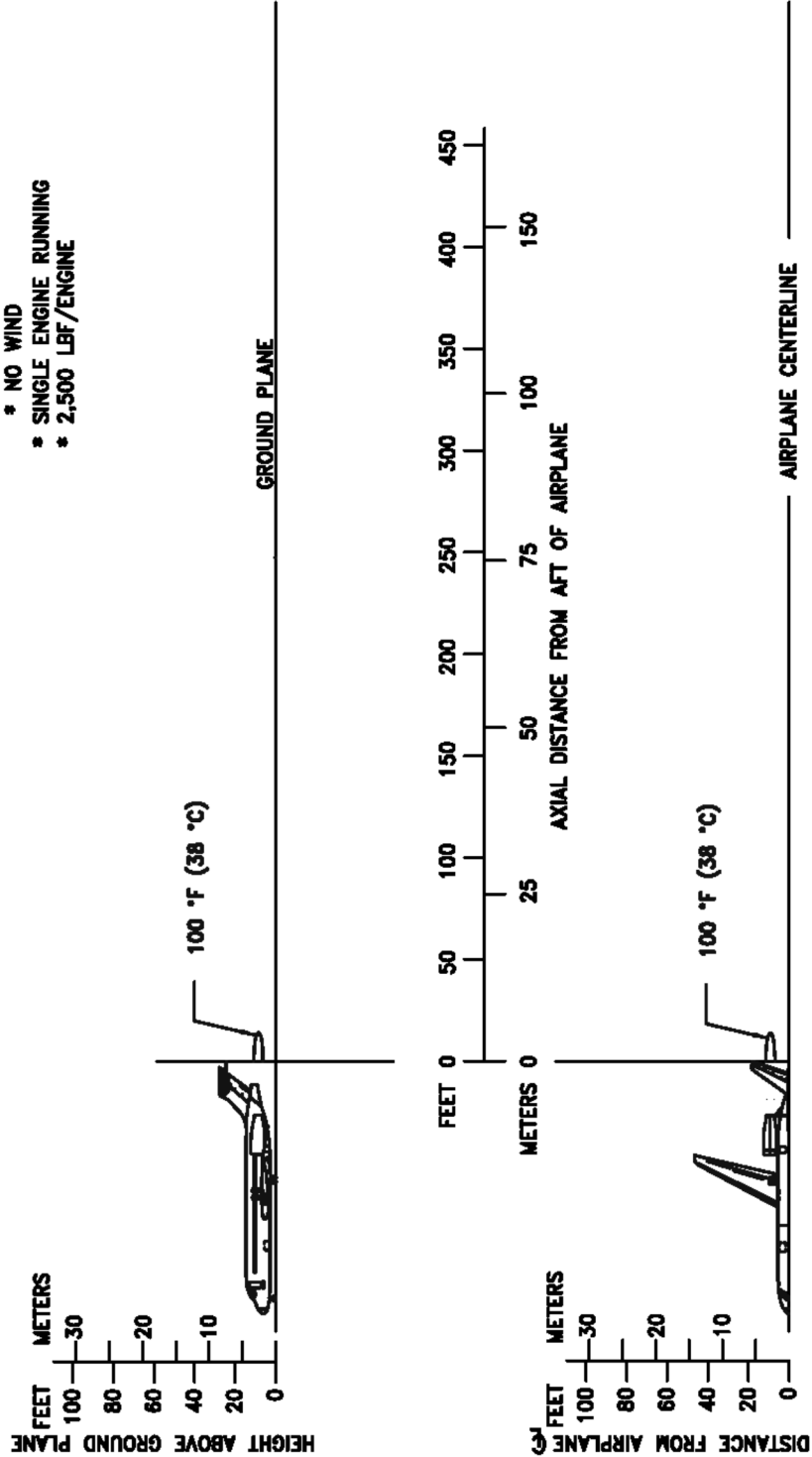

6.1.7 JET ENGINE EXHAUST TEMPERATURE CONTOURS - BREAKAWAY THRUST – BOTH ENGINES
MODEL 717-200

- NOTES:**
- * ENGINE THRUST AT TAKEOFF SETTING
 - * CONTOURS CALCULATED FROM COMPUTER DATA
 - * STANDARD DAY
 - * SEA LEVEL
 - * NO WIND
 - * BOTH ENGINES RUNNING
 - * 21,070 LBF/ENGINE

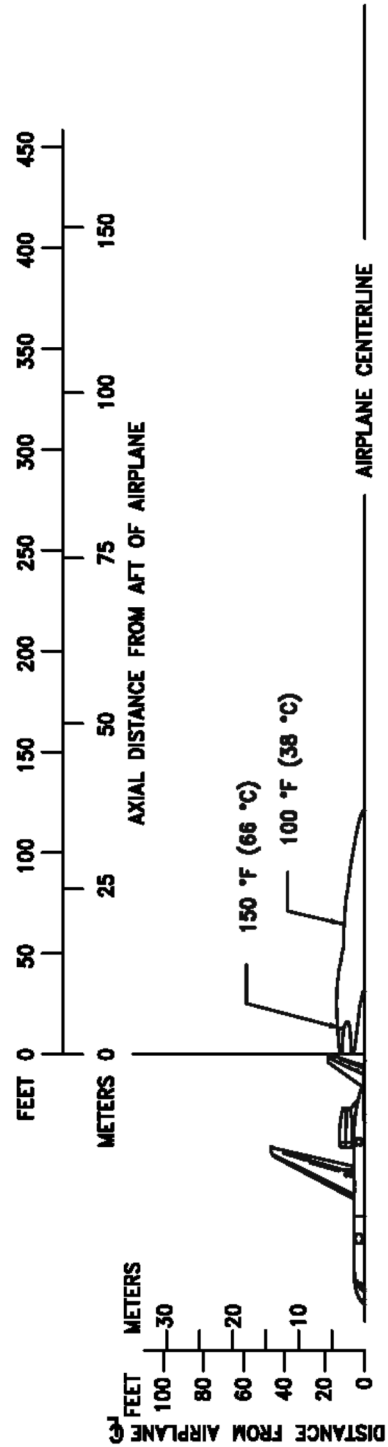
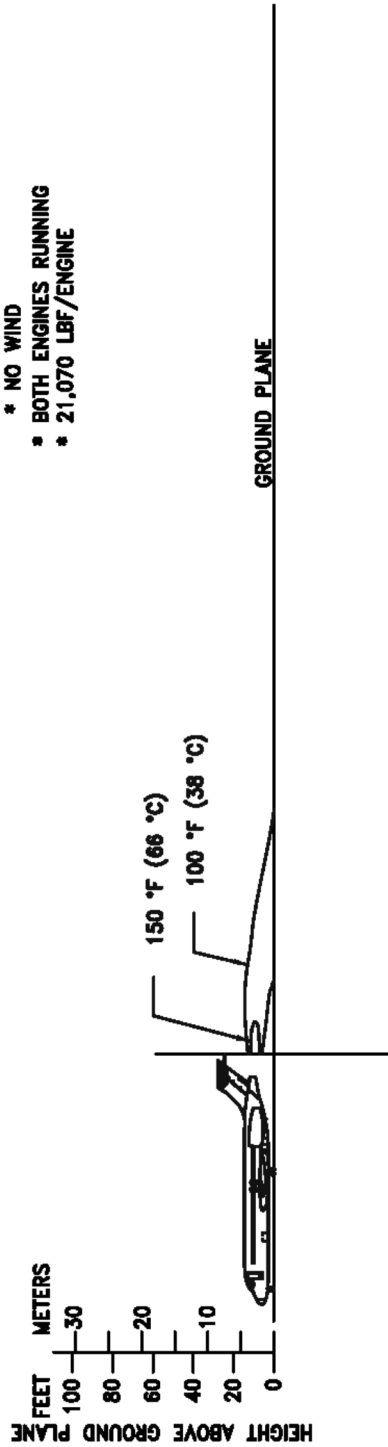

6.1.8 JET ENGINE EXHAUST TEMPERATURE CONTOURS - TAKEOFF THRUST – BOTH ENGINES
MODEL 717-200

6.2 Airport and Community Noise

Airport noise is of major concern to the airport and community planner. The airport is a major element in the community's transportation system and, as such, is vital to its growth. However, the airport must also be a good neighbor, and this can be accomplished only with proper planning. Since aircraft noise extends beyond the boundaries of the airport, it is vital to consider the impact on surrounding communities. Many means have been devised to provide the planner with a tool to estimate the impact of airport operations. Too often they oversimplify noise to the point where the results become erroneous. Noise is not a simple subject; therefore, there are no simple answers.

The cumulative noise contour is an effective tool. However, care must be exercised to ensure that the contours, used correctly, estimate the noise resulting from aircraft operations conducted at an airport.

The size and shape of the single-event contours, which are inputs into the cumulative noise contours, are dependent upon numerous factors. They include the following:

1. Operational Factors

- (a) Aircraft Weight-Aircraft weight is dependent on distance to be traveled, en route winds, payload, and anticipated aircraft delay upon reaching the destination.
- (b) Engine Power Settings-The rates of ascent and descent and the noise levels emitted at the source are influenced by the power setting used.
- (c) Airport Altitude-Higher airport altitude will affect engine performance and thus can influence noise.

2. Atmospheric Conditions-Sound Propagation

- (a) Wind-With stronger headwinds, the aircraft can take off and climb more rapidly relative to the ground. Also, winds can influence the distribution of noise in surrounding communities.
- (b) Temperature and Relative Humidity-The absorption of noise in the atmosphere along the transmission path between the aircraft and the ground observer varies with both temperature and relative humidity.

3. Surface Condition-Shielding, Extra Ground Attenuation (EGA)

- (a) Terrain-If the ground slopes down after takeoff or up before landing, noise will be reduced since the aircraft will be at a higher altitude above ground. Additionally, hills, shrubs, trees, and large buildings can act as sound buffers.

All these factors can alter the shape and size of the contours appreciably. To demonstrate the effect of some of these factors, estimated noise level contours for two different operating conditions are shown below. These contours reflect a given noise level upon a ground level plane at runway elevation.

Condition 1

Landing	Takeoff
Maximum Structural Landing Weight	Maximum Gross Takeoff Weight
10-knot Headwind	Zero Wind
3° Approach	84 °F
84 °F	Humidity 15%
Humidity 15%	

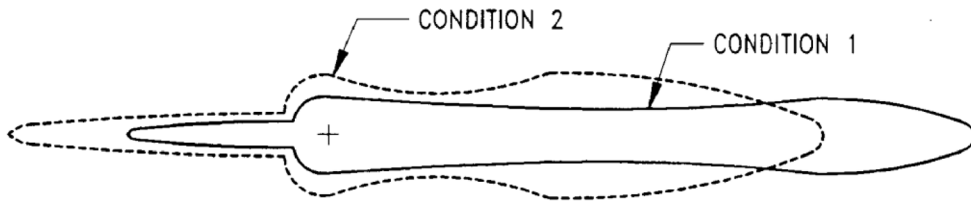

Condition 2

Landing:	Takeoff:
85% of Maximum Structural Landing Weight	80% of Maximum Gross Takeoff Weight
10-knot Headwind	10-knot Headwind
3° Approach	59 °F
59 °F	Humidity 70%
Humidity 70%	

As indicated from these data, the contour size varies substantially with operating and atmospheric conditions. Most aircraft operations are, of course, conducted at less than maximum gross weights because average flight distances are much shorter than maximum aircraft range capability and average load factors are less than 100%. Therefore, in developing cumulative contours for planning purposes, it is recommended that the airlines serving a particular city be contacted to provide operational information.

In addition, there are no universally accepted methods for developing aircraft noise contours or for relating the acceptability of specific zones to specific land uses. It is therefore expected that noise contour data for particular aircraft and the impact assessment methodology will be changing. To ensure that the best currently available information of this type is used in any planning study, it is recommended that it be obtained directly from the Office of Environmental Quality in the Federal Aviation Administration in Washington, D.C.

It should be noted that the contours shown herein are only for illustrating the impact of operating and atmospheric conditions and do not represent the single-event contour of the family of aircraft described in this document. It is expected that the cumulative contours will be developed as required by planners using the data and methodology applicable to their specific study.

7.0 PAVEMENT DATA

- 7.1 General Information**
- 7.2 Landing Gear Footprint**
- 7.3 Maximum Pavement Loads**
- 7.4 Landing Gear Loading on Pavement**
- 7.5 Flexible Pavement Requirements - U.S. Army Corps of Engineers Method S-77-1**
- 7.6 Flexible Pavement Requirements - LCN Conversion**
- 7.7 Rigid Pavement Requirements - Portland Cement Association Design Method**
- 7.8 Rigid Pavement Requirements - LCN Conversion**
- 7.9 Rigid Pavement Requirements - FAA Method**
- 7.10 ACN/PCN Reporting System - Flexible and Rigid Pavements**
- 7.11 Tire Inflation Chart**

7.0 PAVEMENT DATA

7.1 General Information

A brief description of the pavement charts that follow will help in their use for airport planning. Each airplane configuration is depicted with a minimum range of five loads imposed on the main landing gear to aid in interpolation between the discrete values shown. All curves for any single chart represent data based on rated loads and tire pressures considered normal and acceptable by current aircraft tire manufacturer's standards. Tire pressures, where specifically designated on tables and charts, are at values obtained under loaded conditions as certificated for commercial use.

Section 7.2 presents basic data on the landing gear footprint configuration, maximum design taxi loads, and tire sizes and pressures.

Maximum pavement loads for certain critical conditions at the tire-to-ground interface are shown in Section 7.3, with the tires having equal loads on the struts.

Pavement requirements for commercial airplanes are customarily derived from the static analysis of loads imposed on the main landing gear struts. The charts in Section 7.4 are provided in order to determine these loads throughout the stability limits of the airplane at rest on the pavement. These main landing gear loads are used as the point of entry to the pavement design charts, interpolating load values where necessary.

The flexible pavement design curves (Section 7.5) are based on procedures set forth in Instruction Report No. S-77-1, "Procedures for Development of CBR Design Curves," dated June 1977, and as modified according to the methods described in FAA Advisory Circular 150/5320-6D, "Airport Pavement Design and Evaluation", dated July 7, 1995. Instruction Report No. S-77-1 was prepared by the U.S. Army Corps of Engineers Waterways Experiment Station, Soils and Pavements Laboratory, Vicksburg, Mississippi. The line showing 10,000 coverages is used to calculate Aircraft Classification Number (ACN).

The following procedure is used to develop the curves, such as shown in Section 7.5:

1. Having established the scale for pavement depth at the bottom and the scale for CBR at the top, an arbitrary line is drawn representing 10,000 coverages.
2. Values of the aircraft weights on the main landing gear are then plotted.
3. Additional annual departure lines are drawn based on the load lines of the aircraft gross weights already established.

All Load Classification Number (LCN) curves (Sections 7.6 and 7.8) have been developed from a computer program based on data provided in International Civil Aviation Organization (ICAO) document 9157-AN/901, Aerodrome Design Manual, Part 3, "Pavements", Second Edition, 1983. LCN values are shown directly for parameters of weight on main landing gear, tire pressure, and radius of relative stiffness (l) for rigid pavement or pavement thickness or depth factor (h) for flexible pavement.

Rigid pavement design curves (Section 7.7) have been prepared with the Westergaard equation in general accordance with the procedures outlined in the Design of Concrete Airport Pavement (1955 edition) by Robert G. Packard, published by the American Concrete Pavement Association, 3800 North Wilke Road, Arlington Heights, Illinois 60004-1268. These curves are modified to the format described in the Portland Cement Association publication XP6705-2, Computer Program for Airport Pavement Design (Program PDILB), 1968, by Robert G. Packard.

The following procedure is used to develop the rigid pavement design curves shown in Section 7.7:

1. Having established the scale for pavement thickness to the left and the scale for allowable working stress to the right, an arbitrary load line is drawn representing the main landing gear maximum weight to be shown.
2. Values of the subgrade modulus (k) are then plotted.
3. Additional load lines for the incremental values of weight on the main landing gear are drawn on the basis of the curve for $k = 300$, already established.

The ACN/PCN system (Section 7.10) as referenced in ICAO Annex 14, "Aerodromes," First Edition, July 1990, provides a standardized international airplane/pavement rating system replacing the various S, T, TT, LCN, AUW, ISWL, etc., rating systems used throughout the world. ACN is the Aircraft Classification Number and PCN is the Pavement Classification Number. An aircraft having an ACN equal to or less than the PCN can operate on the pavement subject to any limitation on the tire pressure. Numerically, the ACN is two times the derived single-wheel load expressed in thousands of kilograms, where the derived single wheel load is defined as the load on a single tire inflated to 181 psi (1.25 MPa) that would have the same pavement requirements as the aircraft. Computationally, the ACN/PCN system uses the PCA program PDILB for rigid pavements and S-77-1 for flexible pavements to calculate ACN values. The method of pavement evaluation is left up to the airport with the results of their evaluation presented as follows:

PCN	PAVEMENT TYPE	SUBGRADE CATEGORY	TIRE PRESSURE CATEGORY	EVALUATION METHOD
	R = Rigid F = Flexible	A = High B = Medium C = Low D = Ultra Low	W = No Limit X = To 254 psi (1.75 MPa) Y = To 181 psi (1.25 MPa) Z = To 73 psi (0.5 MPa)	T = Technical U = Using Aircraft

Section 7.10.1 shows the aircraft ACN values for flexible pavements. The four subgrade categories are:

- Code A - High Strength - CBR 15
- Code B - Medium Strength - CBR 10
- Code C - Low Strength - CBR 6
- Code D - Ultra Low Strength - CBR 3

Section 7.10.2 shows the aircraft ACN values for rigid pavements. The four subgrade categories are:

- Code A - High Strength, $k = 550 \text{ pci (150 MN/m}^3\text{)}$
- Code B - Medium Strength, $k = 300 \text{ pci (80 MN/m}^3\text{)}$
- Code C - Low Strength, $k = 150 \text{ pci (40 MN/m}^3\text{)}$
- Code D - Ultra Low Strength, $k = 75 \text{ pci (20 MN/m}^3\text{)}$

NOT TO SCALE

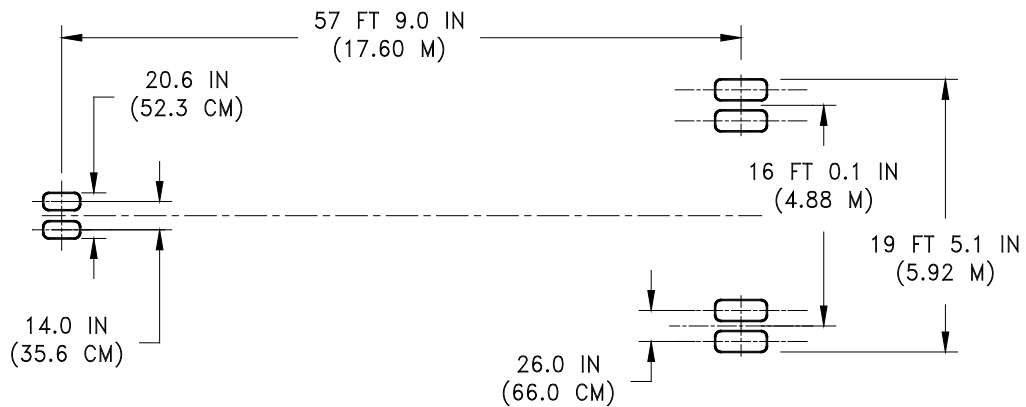

	UNITS	717-200 BASIC				717-200 HGW OPTION
MAXIMUM DESIGN	LBS	111,000	115,000	117,000	119,000	122,000
TAXI WEIGHT	KG	50,349	52,163	53,070	53,977	55,338
WEIGHT ON MAIN GEAR	%	SEE SECTION 7.4				
NOSE GEAR TIRE SIZE	IN	26 x 6.6 TYPE VII 12 PR				
NOSE GEAR	PSI	118	122	124	127	130
TIRE PRESSURE	KG/CM ²	8.30	8.58	8.72	8.93	9.14
MAIN GEAR TIRE SIZE	IN	H41 x 15.0 – 19 24 PR				
MAIN GEAR	PSI	152	158	163	164	164
TIRE PRESSURE	KG/CM ²	10.69	11.11	11.46	11.53	11.53

7.2 LANDING GEAR FOOTPRINT
MODEL 717-200

D6-58330

REV B

NOVEMBER 2014 71

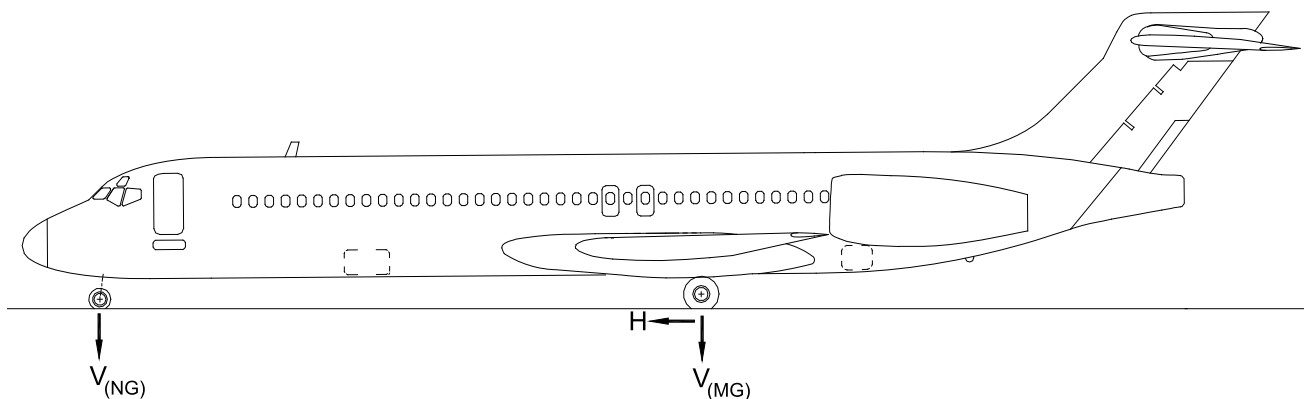

$V_{(NG)}$ = MAXIMUM VERTICAL NOSE GEAR GROUND LOAD AT MOST FORWARD CENTER OF GRAVITY

$V_{(MG)}$ = MAXIMUM VERTICAL MAIN GEAR GROUND LOAD AT MOST AFT CENTER OF GRAVITY

H = MAXIMUM HORIZONTAL GROUND LOAD FROM BRAKING

NOTE: ALL LOADS CALCULATED USING AIRPLANE MAXIMUM TAXI WEIGHT

MODEL	UNIT	MAXIMUM DESIGN TAXI WEIGHT	$V_{(NG)}$		$V_{(MG)}$	H PER STRUT	
			STATIC AT MOST FWD C.G.	STATIC + BRAKING 10 FT/SEC ² DECEL	MAX LOAD AT STATIC AFT C.G.	STEADY BRAKING 10 FT/SEC ² DECEL	AT INSTANTANEOUS BRAKING ($\mu=0.8$)
717-200	LB	111,000	10,450	15,310	53,450	17,200	42,760
	KG	50,349	4,740	6,944	24,244	7,802	19,396
	LB	115,000	10,800	15,840	55,300	17,830	44,240
	KG	52,163	4,899	7,185	25,084	8,088	20,067
	LB	117,000	10,960	16,090	56,180	18,140	44,940
	KG	53,070	4,971	7,298	25,483	8,228	20,384
	LB	119,000	11,150	16,370	57,050	18,450	45,640
	KG	53,977	5,058	7,425	25,877	8,339	20,702
	LB	122,000	11,380	16,730	57,600	18,910	46,100
	KG	55,338	5,162	7,589	26,127	8,577	20,911

7.3 MAXIMUM PAVEMENT LOADS MODEL 717-200

D6-58330

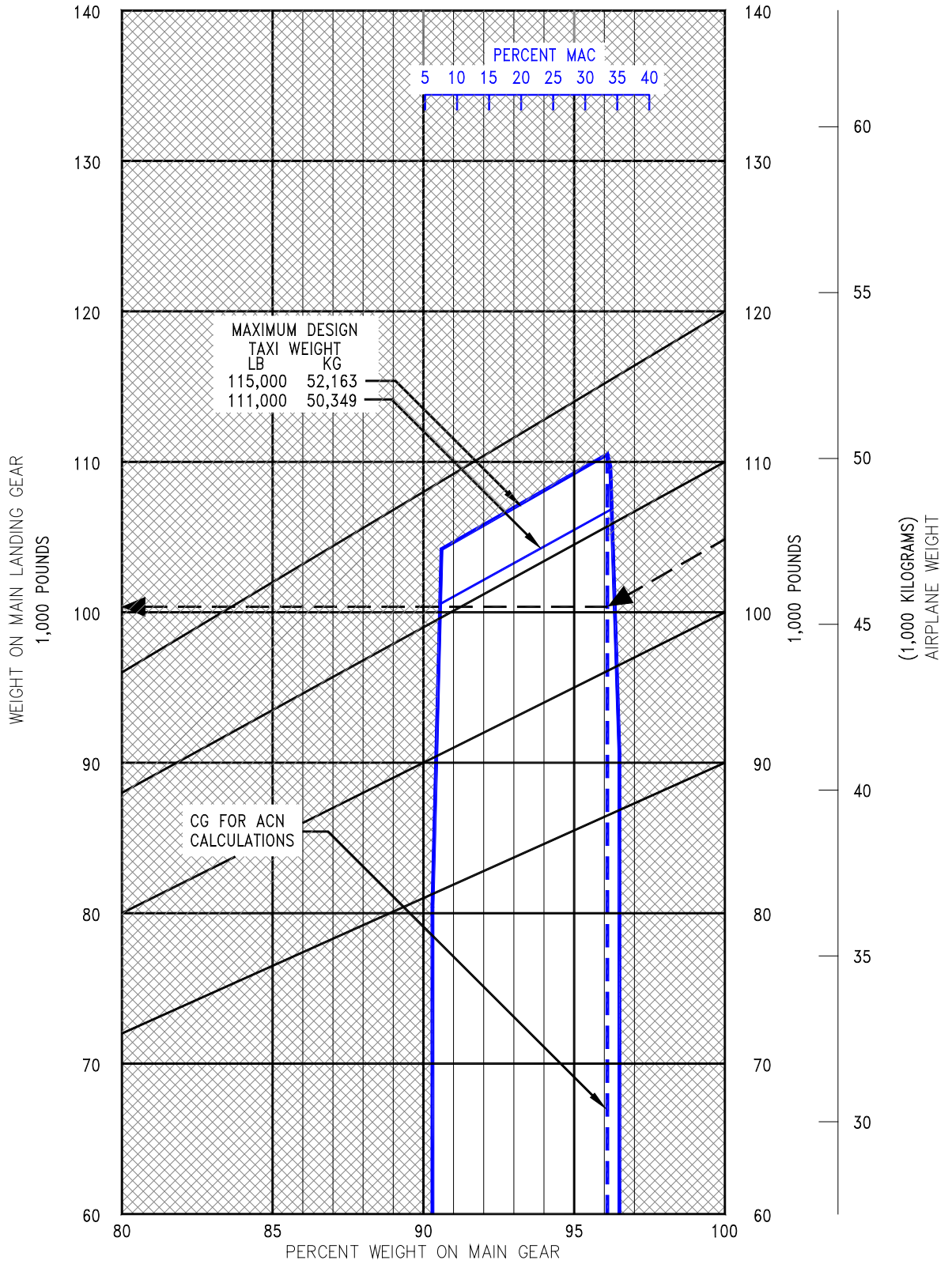

7.4.1 LANDING GEAR LOADING ON PAVEMENT
MODEL 717-200

D6-58330

REV B

NOVEMBER 2014 73

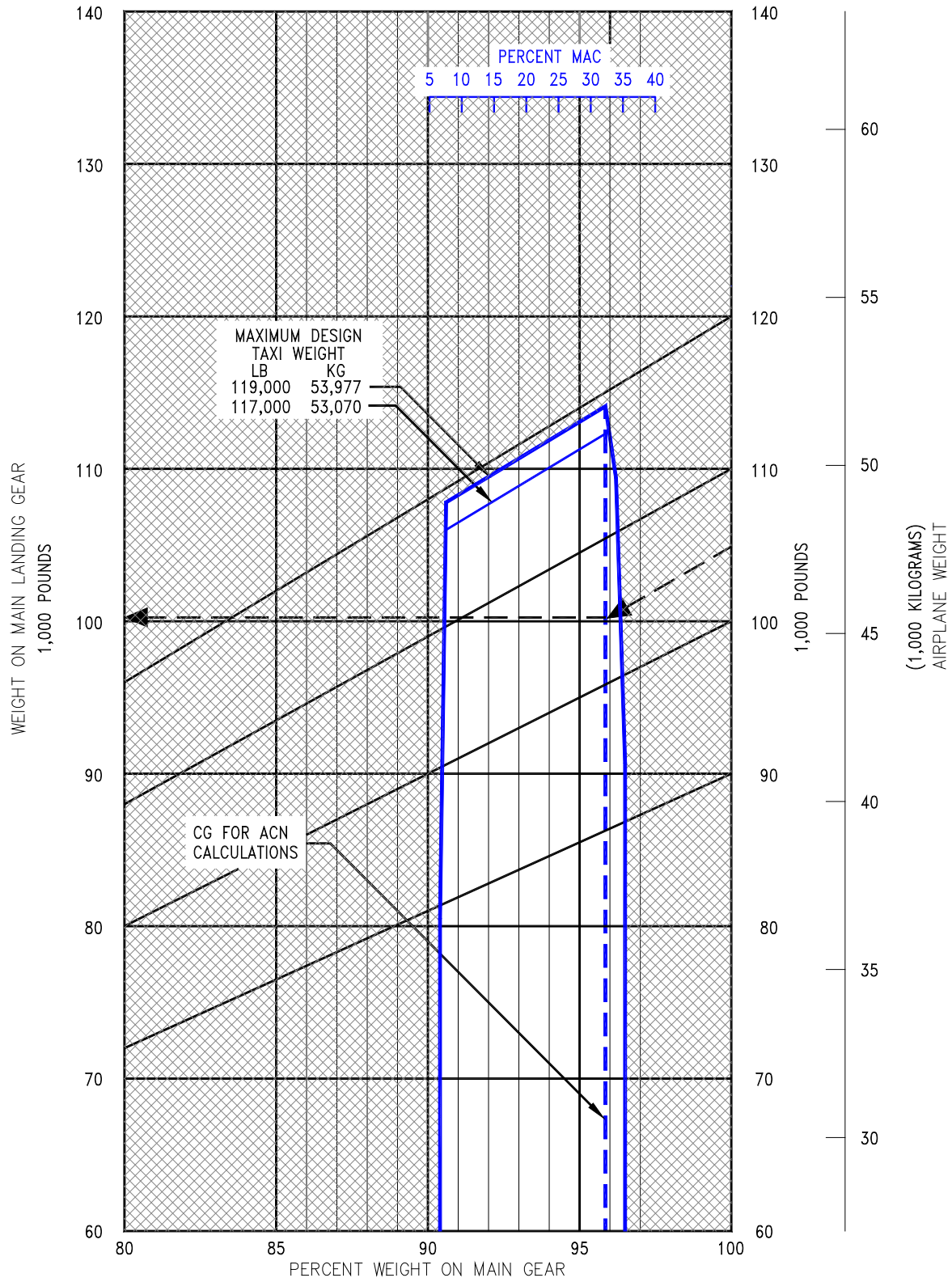

7.4.2 LANDING GEAR LOADING ON PAVEMENT
MODEL 717-200

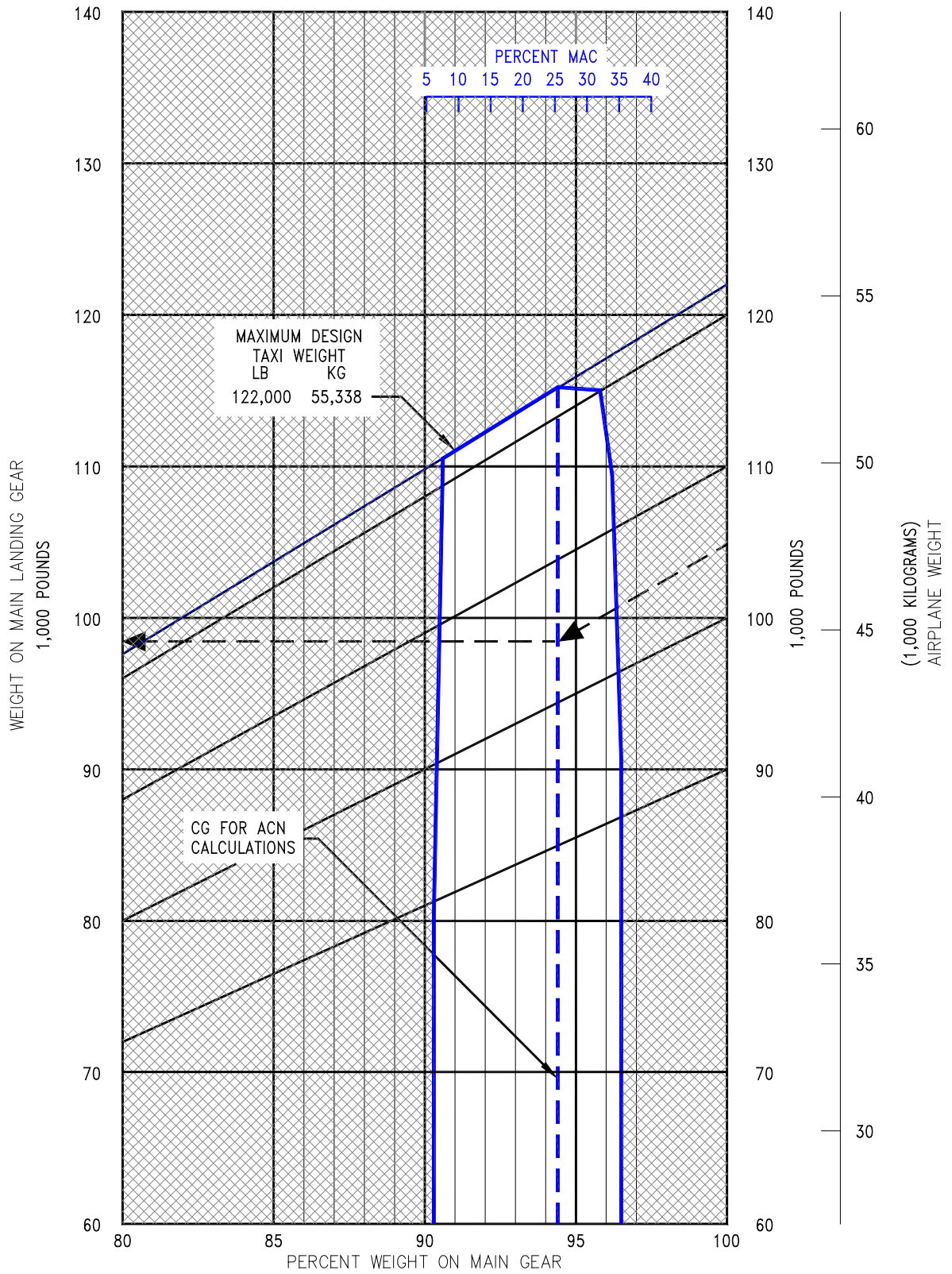

7.4.3 LANDING GEAR LOADING ON PAVEMENT
MODEL 717-200

D6-58330

REV B

NOVEMBER 2014 75

7.5 Flexible Pavement Requirements - U.S. Army Corps of Engineers Method (S-77-1)

The following flexible-pavement design chart presents the data of five incremental main-gear loads at the minimum tire pressure required at the maximum design taxi weight.

In the example shown on the next page, for a CBR of 12 and an annual departure level of 6,000, the required flexible pavement thickness for an airplane with a main gear loading of 100,000 pounds is 17.2 inches.

The line showing 10,000 coverages is used for ACN calculations (see Section 7.10).

The FAA design method uses a similar procedure using total airplane weight instead of weight on the main landing gears. The equivalent main gear loads for a given airplane weight could be calculated from Section 7.4.

NOTES:

- * TIRES - H41.0 x 15.0-19 24 PR
- * PRESSURE CONSTANT AT 164 PSI (11.53 KG/SQ CM)

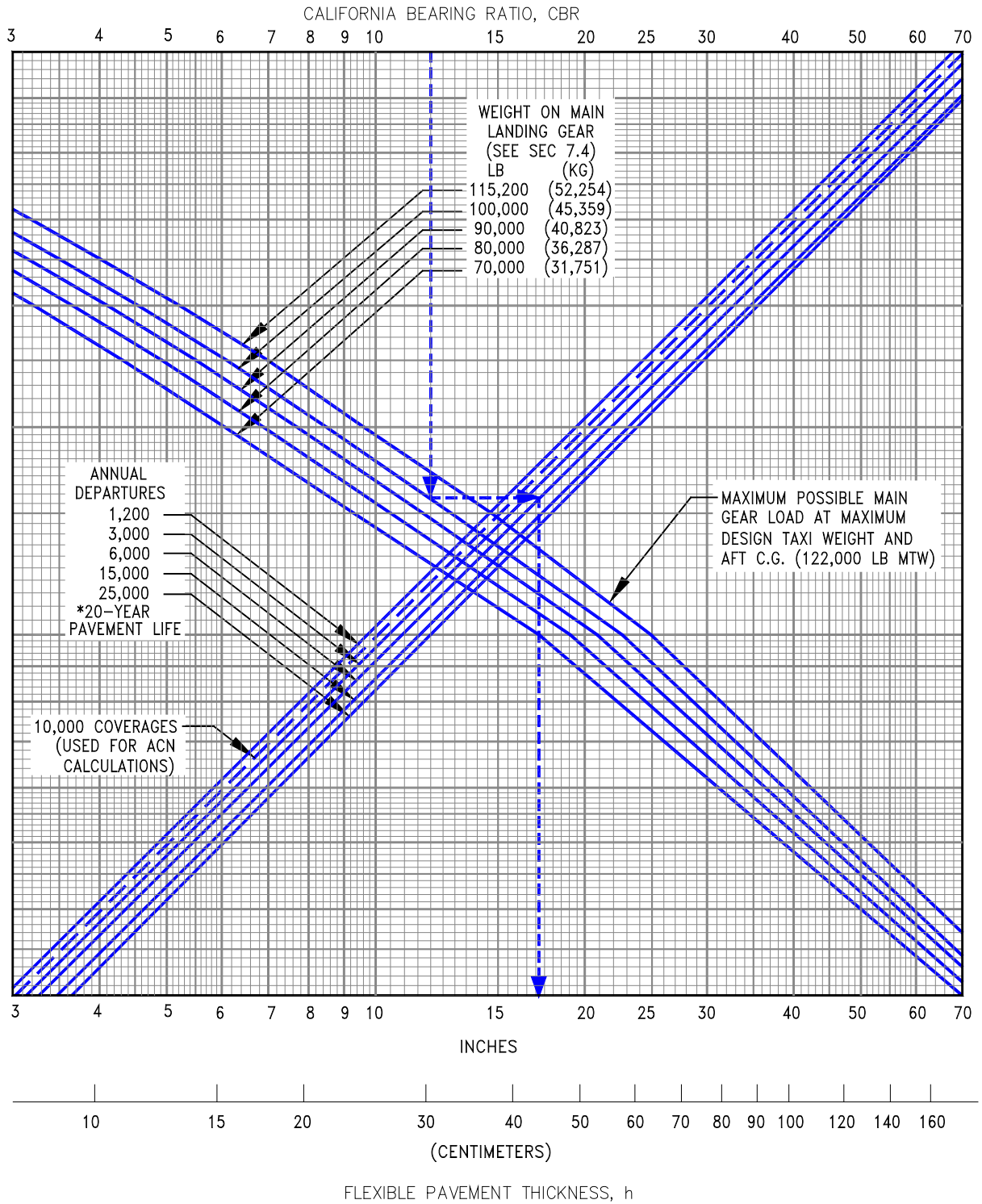

**7.5 FLEXIBLE PAVEMENT REQUIREMENTS - U.S. ARMY CORPS OF ENGINEERS
DESIGN METHOD (S-77-1)
MODEL 717-200**

D6-58330

REV B

NOVEMBER 2014 77

7.6 Flexible Pavement Requirements - LCN Method

To determine the airplane weight that can be accommodated on a particular flexible pavement, both the Load Classification Number (LCN) of the pavement and the thickness must be known.

In the example shown on the next page, flexible pavement thickness is shown at 9.8 in. with an LCN of 50. For these conditions, the maximum allowable weight permissible on the main landing gear is 115,200 lb for an airplane with 164-psi main gear tires.

Note: If the resultant aircraft LCN is not more than 10% above the published pavement LCN, the bearing strength of the pavement can be considered sufficient for unlimited use by the airplane. The figure 10% has been chosen as representing the lowest degree of variation in LCN that is significant (reference: ICAO Aerodrome Manual, Part 2, "Aerodrome Physical Characteristics," Chapter 4, Paragraph 4.1.5.7v, 2nd Edition dated 1965).

NOTES:
 * TIRES - H41 x 15.0 - 19 24PR, TIRE PRESSURE 164 PSI (11.53 KG/SQ CM)
 * EQUIVALENT SINGLE-WHEEL LOADS ARE DERIVED FROM ICAO AERODROME MANUAL, PART 2 PAR. 4.1.3, DATED 1965.

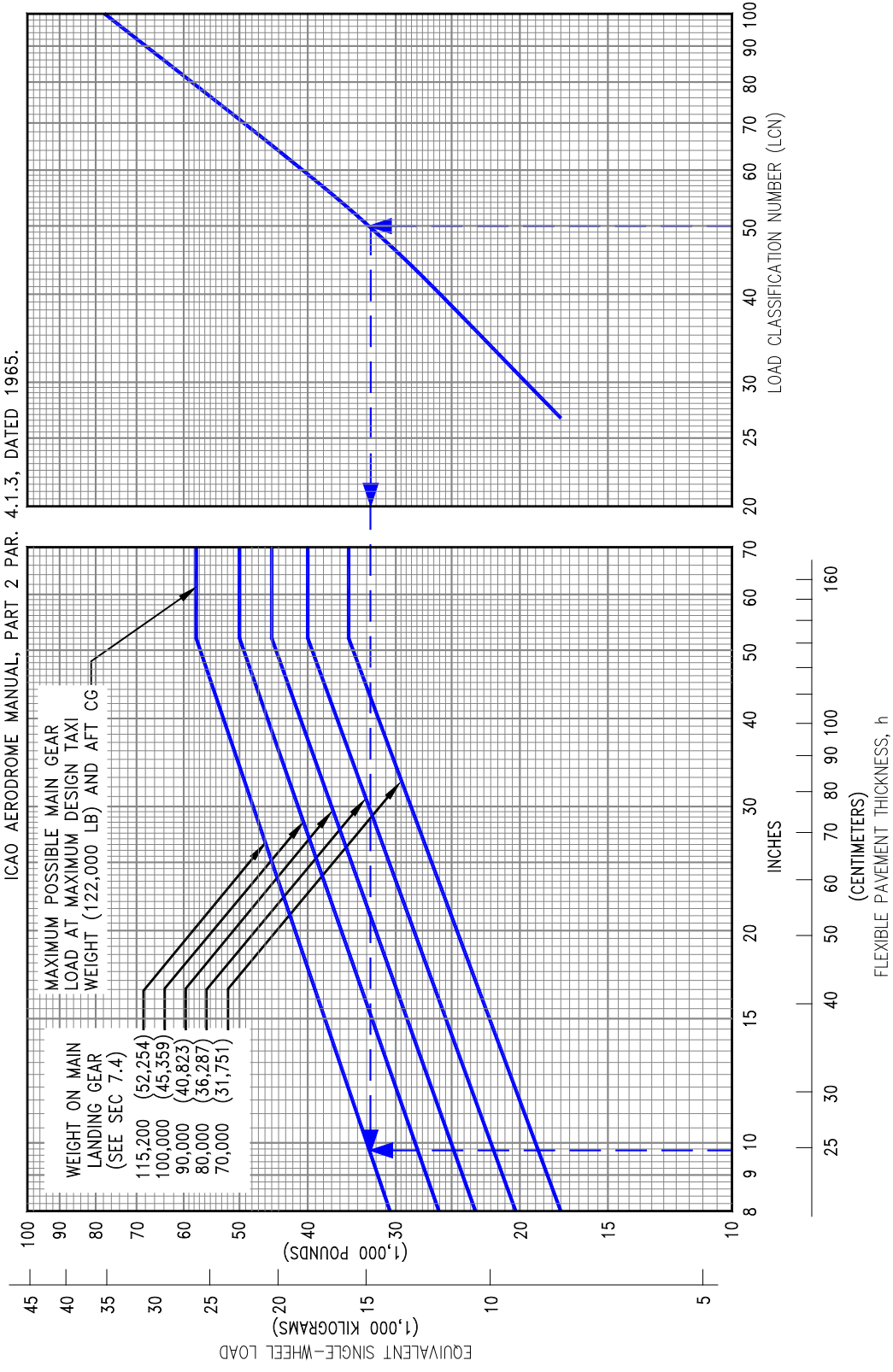

7.6 FLEXIBLE PAVEMENT REQUIREMENTS - LCN METHOD
 MODEL 717-200

7.7 Rigid Pavement Requirements - Portland Cement Association Design Method

The Portland Cement Association method of calculating rigid pavement requirements is based on the computerized version of "Design of Concrete Airport Pavement" (Portland Cement Association, 1955) as described in XP6705-2, "Computer Program for Airport Pavement Design" by Robert G. Packard, Portland Cement Association, 1968.

The following rigid pavement design chart presents the data for five incremental main gear loads at the minimum tire pressure required at the maximum design taxi weight.

In the example shown in the next page, for an allowable working stress of 550 psi, a main gear load of 115,200 lb, and a subgrade strength (k) of 150, the required rigid pavement thickness is 9.4 in.

NOTE: TIRES - H41 x 15.0 - 19 24PR

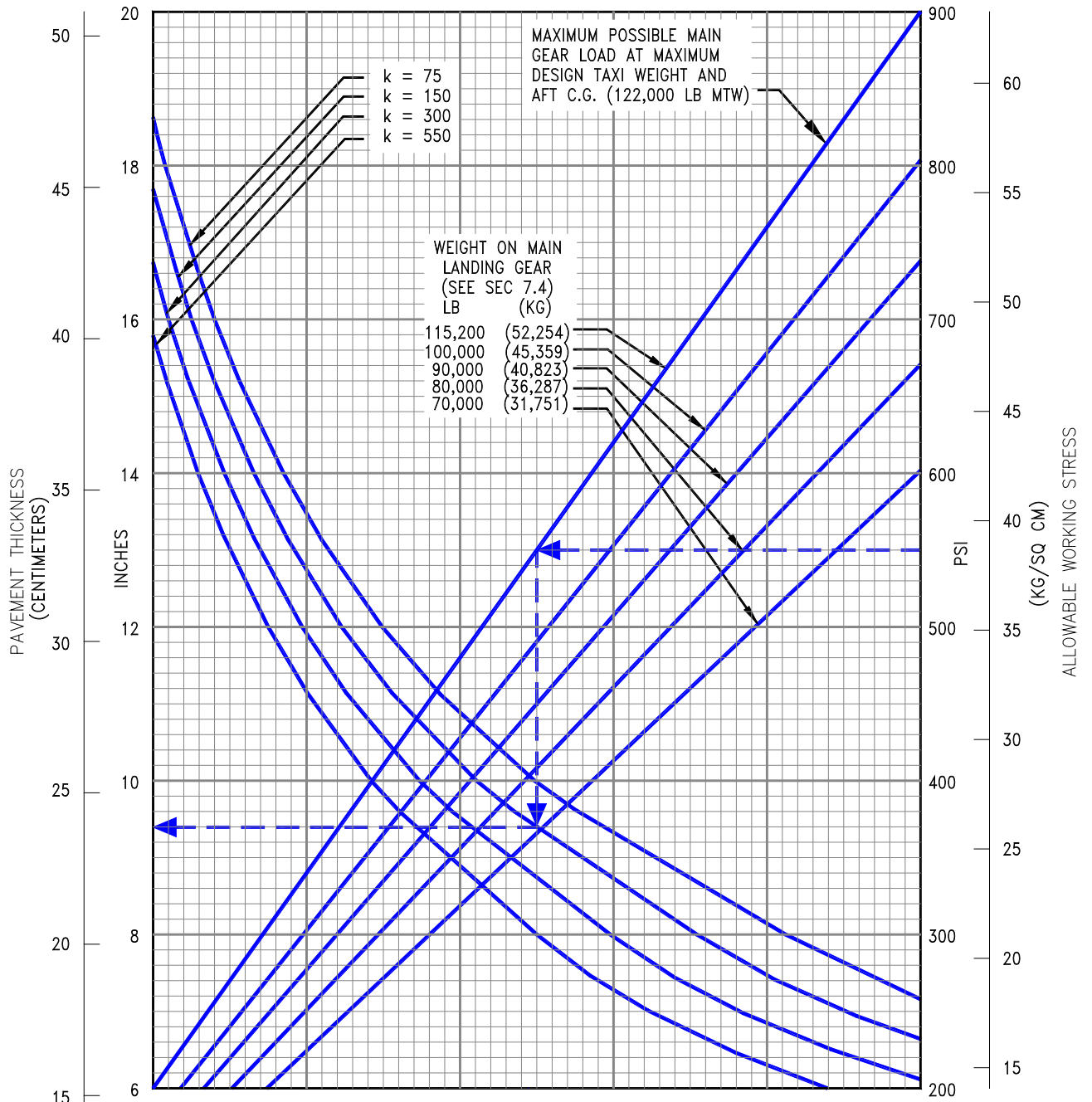

NOTE:
 THE VALUES OBTAINED BY USING THE
 MAXIMUM LOAD REFERENCE LINE AND
 ANY VALUE OF k ARE EXACT.
 FOR LOADS LESS THAN MAXIMUM, THE CURVES
 ARE EXACT FOR $k = 300$ BUT DEVIATE
 SLIGHTLY FOR OTHER VALUES OF k .

REFERENCES:
 "DESIGN OF CONCRETE AIRPORT
 PAVEMENT" AND "COMPUTER
 PROGRAM FOR AIRPORT PAVEMENT
 DESIGN - PROGRAM PDILB"
 PORTLAND CEMENT ASSOCIATION.

7.7 RIGID PAVEMENT REQUIREMENTS - PORTLAND CEMENT ASSOCIATION METHOD
 MODEL 717-200

D6-58330

REV B

NOVEMBER 2014 81

7.8 Rigid Pavement Requirements - LCN Conversion

To determine the airplane weight that can be accommodated on a particular rigid pavement, both the LCN of the pavement and the radius of relative stiffness (l) of the pavement must be known.

In the example shown in Section 7.8.2, for a rigid pavement with a radius of relative stiffness of 54 and an LCN of 60, the maximum allowable weight permissible on the main landing gear is 100,000 lb for an airplane with 164-psi main tires.

Note: If the resultant aircraft LCN is not more than 10% above the published pavement LCN, the bearing strength of the pavement can be considered sufficient for unlimited use by the airplane. The figure 10% has been chosen as representing the lowest degree of variation in LCN that is significant (reference: ICAO Aerodrome Manual, Part 2, "Aerodrome Physical Characteristics," Chapter 4, Paragraph 4.1.5.7v, 2nd Edition dated 1965).

RADIUS OF RELATIVE STIFFNESS (I)
VALUES IN INCHES

$$I = \sqrt[4]{\frac{Ed^3}{12(1-\mu^2)k}} = 24.1652 \sqrt[4]{\frac{d^3}{k}}$$

WHERE: E = YOUNG'S MODULUS OF ELASTICITY = 4×10^6 psi
 k = SUBGRADE MODULUS, LB PER CU IN
 d = RIGID PAVEMENT THICKNESS, IN
 μ = POISSON'S RATIO = 0.15

d	k = 75	k = 100	k = 150	k = 200	k = 250	k = 300	k = 350	k = 400	k = 500	k = 550
6.0	31.48	29.29	26.47	24.63	23.30	22.26	21.42	20.71	19.59	19.13
6.5	33.42	31.10	28.11	26.16	24.74	23.63	22.74	21.99	20.80	20.31
7.0	35.33	32.88	29.71	27.65	26.15	24.99	24.04	23.25	21.99	21.47
7.5	37.21	34.63	31.29	29.12	27.54	26.31	25.32	24.49	23.16	22.61
8.0	39.06	36.35	32.84	30.56	28.91	27.62	26.57	25.70	24.31	23.73
8.5	40.87	38.04	34.37	31.99	30.25	28.90	27.81	26.90	25.44	24.84
9.0	42.66	39.70	35.88	33.39	31.57	30.17	29.03	28.07	26.55	25.93
9.5	44.43	41.35	37.36	34.77	32.88	31.42	30.23	29.24	27.65	27.00
10.0	46.17	42.97	38.83	36.13	34.17	32.65	31.41	30.38	28.73	28.06
10.5	47.89	44.57	40.27	37.48	35.44	33.87	32.58	31.52	29.81	29.10
11.0	49.59	46.15	41.70	38.81	36.70	35.07	33.74	32.63	30.86	30.14
11.5	51.27	47.72	43.12	40.12	37.95	36.26	34.89	33.74	31.91	31.16
12.0	52.94	49.26	44.51	41.43	39.18	37.43	36.02	34.83	32.94	32.17
12.5	54.58	50.80	45.90	42.71	40.40	38.60	37.14	35.92	33.97	33.17
13.0	56.21	52.31	47.27	43.99	41.60	39.75	38.25	36.99	34.98	34.16
13.5	57.83	53.81	48.63	45.25	42.80	40.89	39.34	38.05	35.99	35.14
14.0	59.43	55.30	49.97	46.50	43.98	42.02	40.43	39.10	36.98	36.11
14.5	61.01	56.78	51.30	47.74	45.15	43.14	41.51	40.15	37.97	37.07
15.0	62.58	58.24	52.62	48.97	46.32	44.25	42.58	41.18	38.95	38.03
15.5	64.14	59.69	53.93	50.19	47.47	45.35	43.64	42.21	39.92	38.98
16.0	65.69	61.13	55.23	51.40	48.61	46.45	44.69	43.22	40.88	39.92
16.5	67.22	62.55	56.52	52.60	49.75	47.53	45.73	44.23	41.83	40.85
17.0	68.74	63.97	57.80	53.79	50.87	48.61	46.77	45.23	42.78	41.77
17.5	70.25	65.38	59.07	54.97	51.99	49.68	47.80	46.23	43.72	42.69
18.0	71.75	66.77	60.34	56.15	53.10	50.74	48.82	47.22	44.65	43.60
19.0	74.72	69.54	62.83	58.47	55.30	52.84	50.84	49.17	46.50	45.41
20.0	77.65	72.26	65.30	60.77	57.47	54.91	52.83	51.10	48.33	47.19
21.0	80.55	74.96	67.73	63.03	59.61	56.95	54.80	53.00	50.13	48.95
22.0	83.41	77.62	70.14	65.27	61.73	58.98	56.75	54.88	51.91	50.68
23.0	86.23	80.25	72.51	67.48	63.82	60.98	58.67	56.74	53.67	52.40
24.0	89.03	82.85	74.86	69.67	65.89	62.95	60.57	58.58	55.41	54.10
25.0	91.80	85.43	77.19	71.84	67.94	64.91	62.46	60.41	57.13	55.78

**7.8.1 RADIUS OF RELATIVE STIFFNESS
(REFERENCE: PORTLAND CEMENT ASSOCIATION)**

D6-58330

REV B

NOVEMBER 2014 83

NOTES: * TIRES - H41 x 15.0 - 19 24PR
 * EQUIVALENT SINGLE-WHEEL LOADS ARE DERIVED FROM ICAO AERODROME MANUAL, PART 2 PAR 4.1.3, DATED 1965.

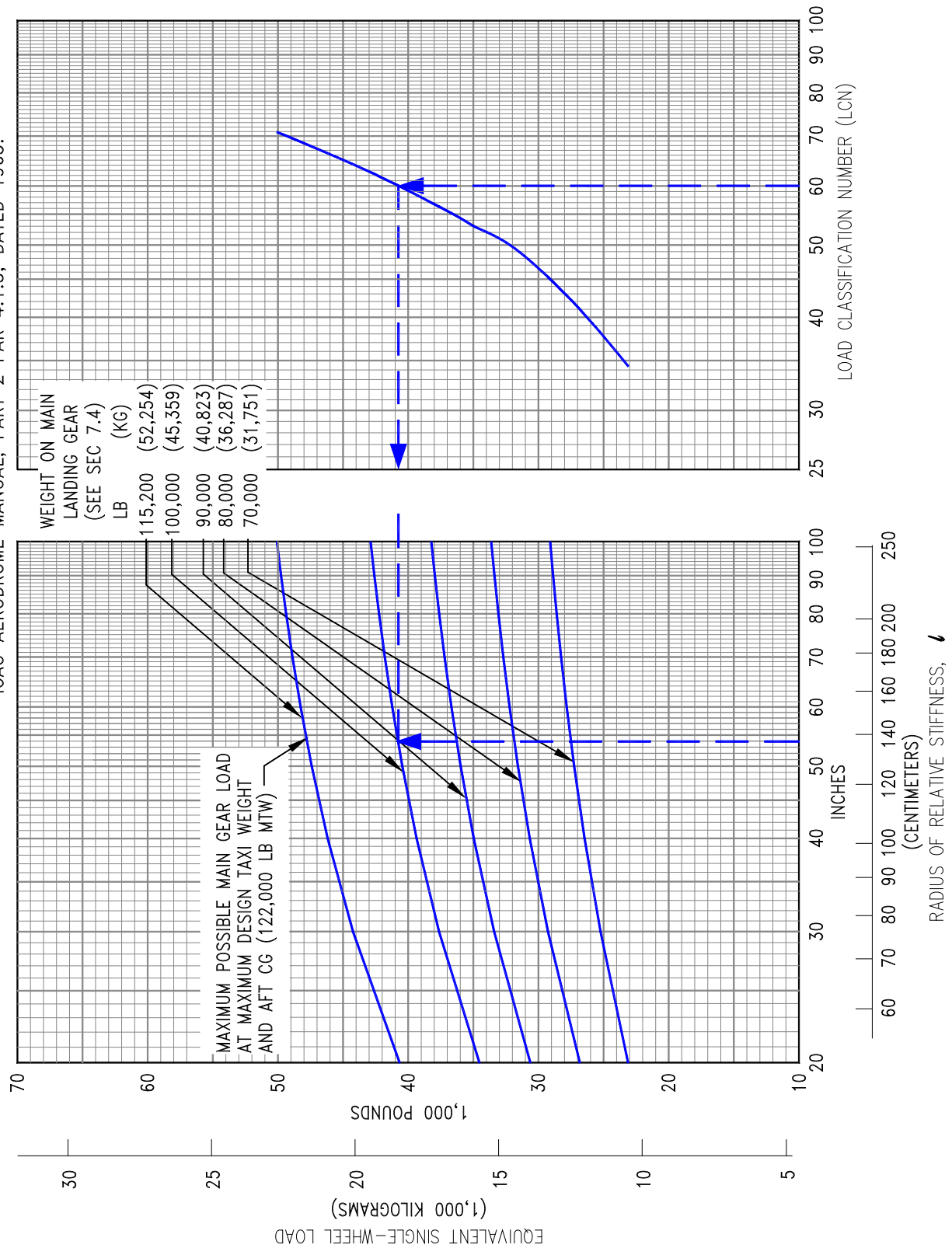

7.8.2 RIGID PAVEMENT REQUIREMENTS - LCN CONVERSION
MODEL 717-200

7.9 Rigid Pavement Requirements - FAA Design Method

The following rigid pavement design chart presents data on five incremental main gear weights at the minimum tire pressure required at the maximum design taxi weight.

In the example shown, the pavement flexural strength is shown at 650 psi, the subgrade strength is shown at $k = 150$, and the annual departure level is 6,000. For these conditions, the required rigid pavement thickness for an airplane with a main gear loading of 100,000 pounds is 11.0 inches.

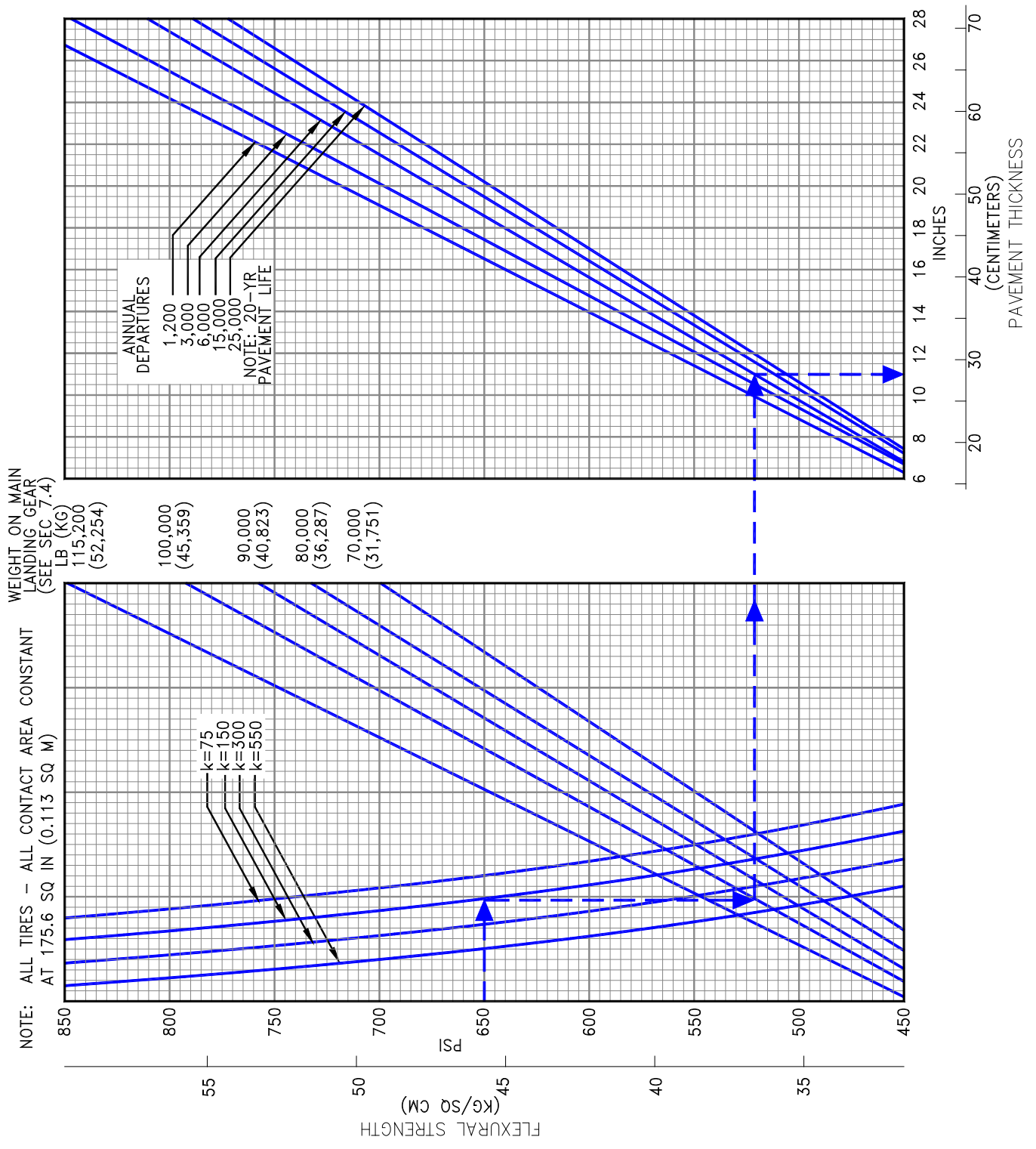

7.9 RIGID PAVEMENT REQUIREMENTS - FAA DESIGN METHOD
MODEL 717-200

7.10 ACN/PCN Reporting System - Flexible and Rigid Pavements

To determine the ACN of an aircraft on flexible or rigid pavement, both the aircraft gross weight and the subgrade strength category must be known. In the chart in Section 7.10.1, for an aircraft with gross weight of 106,000 lb and medium subgrade strength (Code A), the flexible pavement ACN is 26.5. In Section 7.10.4, for the same gross weight and medium subgrade strength (Code A), the rigid pavement ACN is 29.5.

Note: An aircraft with an ACN equal to or less than the reported PCN can operate on that pavement subject to any limitations on the tire pressure. (Ref.: ICAO Annex 14 Aerodromes, First Edition, July 1990.)

The following table provides ACN data in tabular format similar to the one used by ICAO in the “Aerodrome Design Manual Part 3, Pavements”. If the ACN for an intermediate weight between maximum taxi weight and the empty weight of the aircraft is required, Figures 7.10.1 through 7.10.6 should be consulted.

AIRCRAFT TYPE	ALL-UP MASS/ OPERATING MASS EMPTY LB (KG)	LOAD ON ONE MAIN GEAR LEG (%)	TIRE PRESSURE PSI (MPa)	ACN FOR RIGID PAVEMENT SUBGRADES – MN/m ³				ACN FOR FLEXIBLE PAVEMENT SUBGRADES – CBR			
				HIGH 150	MEDIUM 80	LOW 40	ULTRA LOW 20	HIGH 15	MEDIUM 10	LOW 6	ULTRA LOW 3
717-200	111,000 (50,349) 67,500 (30,618)	48.15	152 (1.05)	31 17	33 18	35 19	36 20	28 15	29 16	33 18	36 21
	115,000 (52,163) 67,500 (30,618)	48.05	158 (1.09)	33 17	34 18	36 19	38 20	29 15	31 16	35 18	38 21
	117,000 (53,070) 67,500 (30,618)	48.00	161 (1.11)	34 17	35 18	37 19	38 20	30 16	31 16	35 18	38 21
	119,000 (53,977) 67,500 (30,618)	47.93	164 (1.13)	34 17	36 18	38 20	39 20	30 16	32 16	36 18	39 21
	122,000(55,338) 68,500 (31,071)	47.20	164 (1.13)	35 17	36 18	38 20	40 20	31 16	32 16	37 18	39 21

NOTES:
 * TIRES – H41 x 15.0 – 19, 24PR
 * PRESSURE – 158 PSI (11.11 KG/SQ CM)

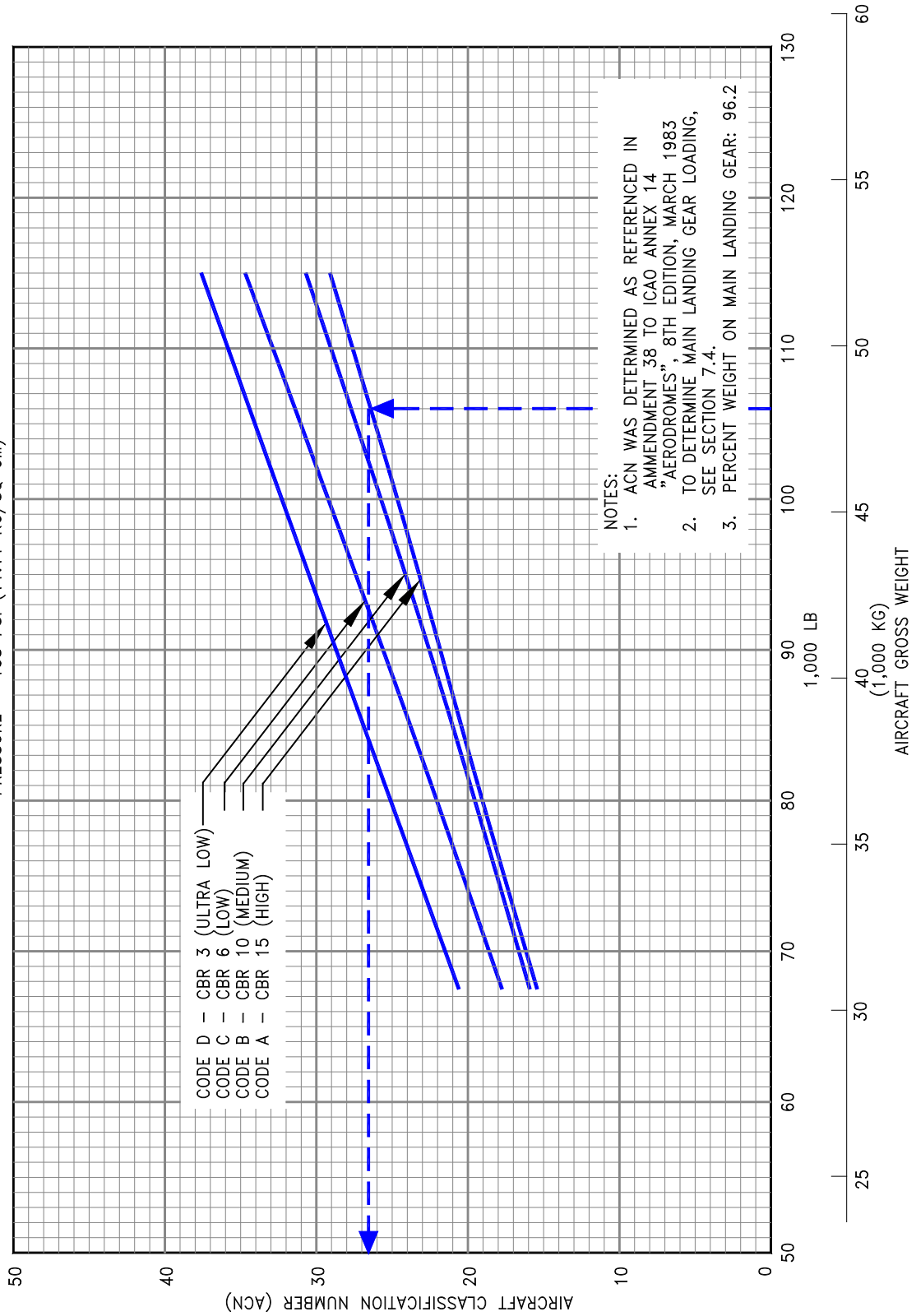

**7.10.1 AIRCRAFT CLASSIFICATION NUMBER - FLEXIBLE PAVEMENT – 115,000 LB MTW
 MODEL 717-200**

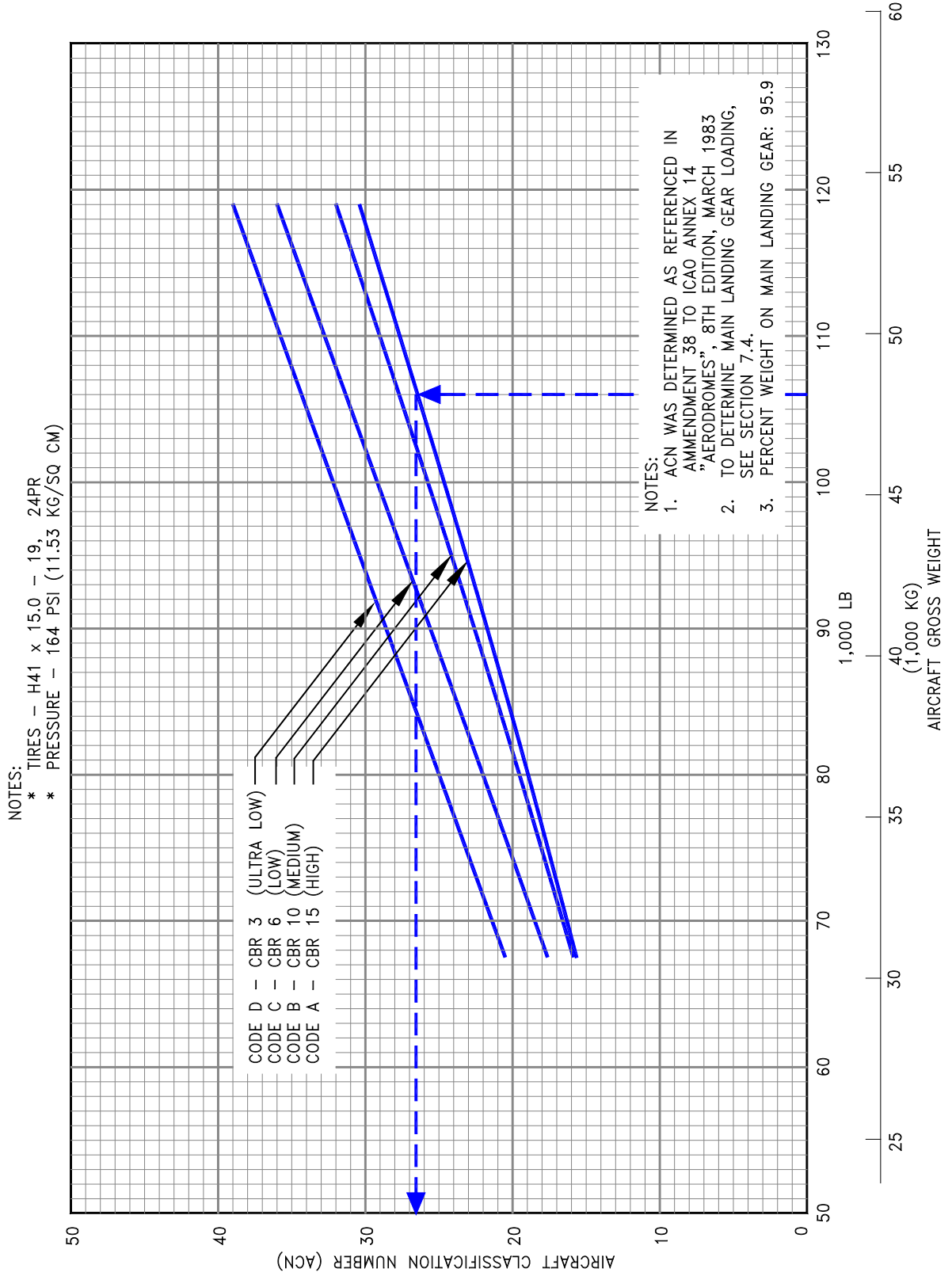

**7.10.2 AIRCRAFT CLASSIFICATION NUMBER - FLEXIBLE PAVEMENT - 119,000 LB MTW
 MODEL 717-200**

NOTES:
 * TIRES - H41 x 15.0 - 19, 24PR
 * PRESSURE - 164 PSI (11.53 KG/SQ CM)

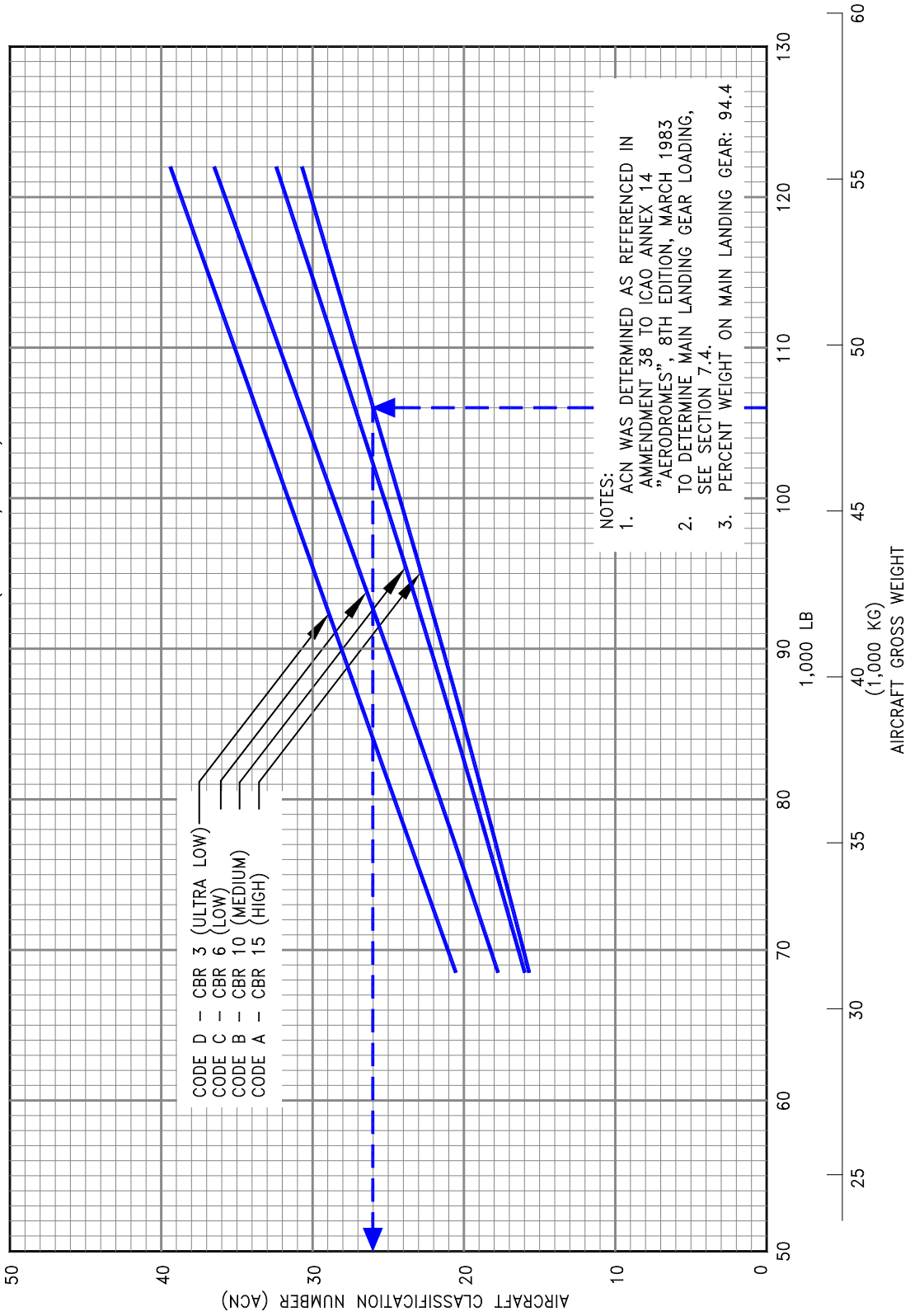

NOTES:
 1. ACN WAS DETERMINED AS REFERENCED IN AMENDMENT 38 TO ICAO ANNEX 14 "AERODROMES", 8TH EDITION, MARCH 1983
 2. TO DETERMINE MAIN LANDING GEAR LOADING, SEE SECTION 7.4.
 3. PERCENT WEIGHT ON MAIN LANDING GEAR: 94.4

7.10.3 AIRCRAFT CLASSIFICATION NUMBER - FLEXIBLE PAVEMENT - 122,000 LB MTW MODEL 717-200

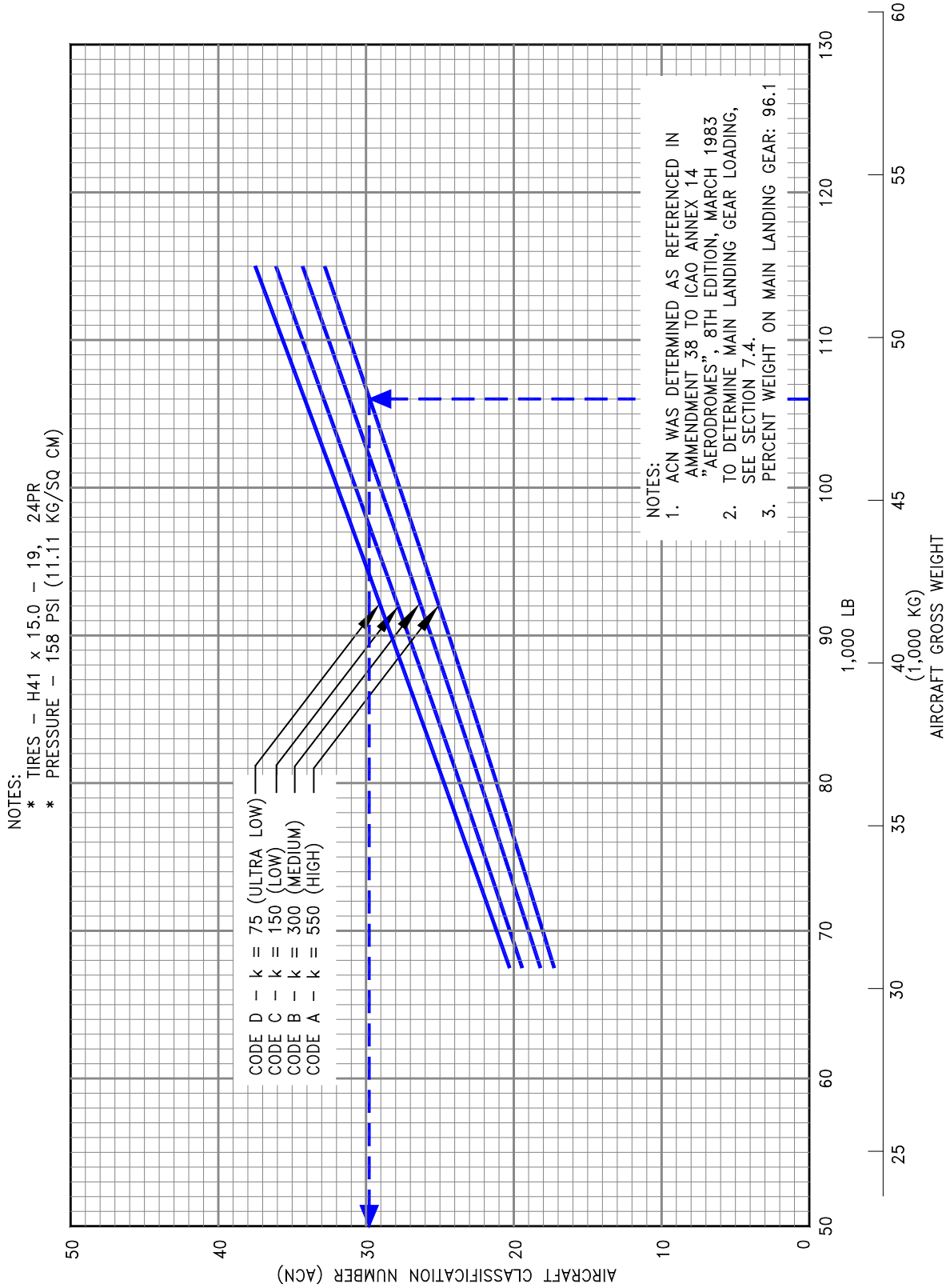

7.10.4 AIRCRAFT CLASSIFICATION NUMBER - RIGID PAVEMENT – 115,000 LB MTW
 MODEL 717-200

NOTES:
 * TIRES - H41 x 15.0 - 19, 24PR
 * PRESSURE - 164 PSI (11.53 KG/SQ CM)

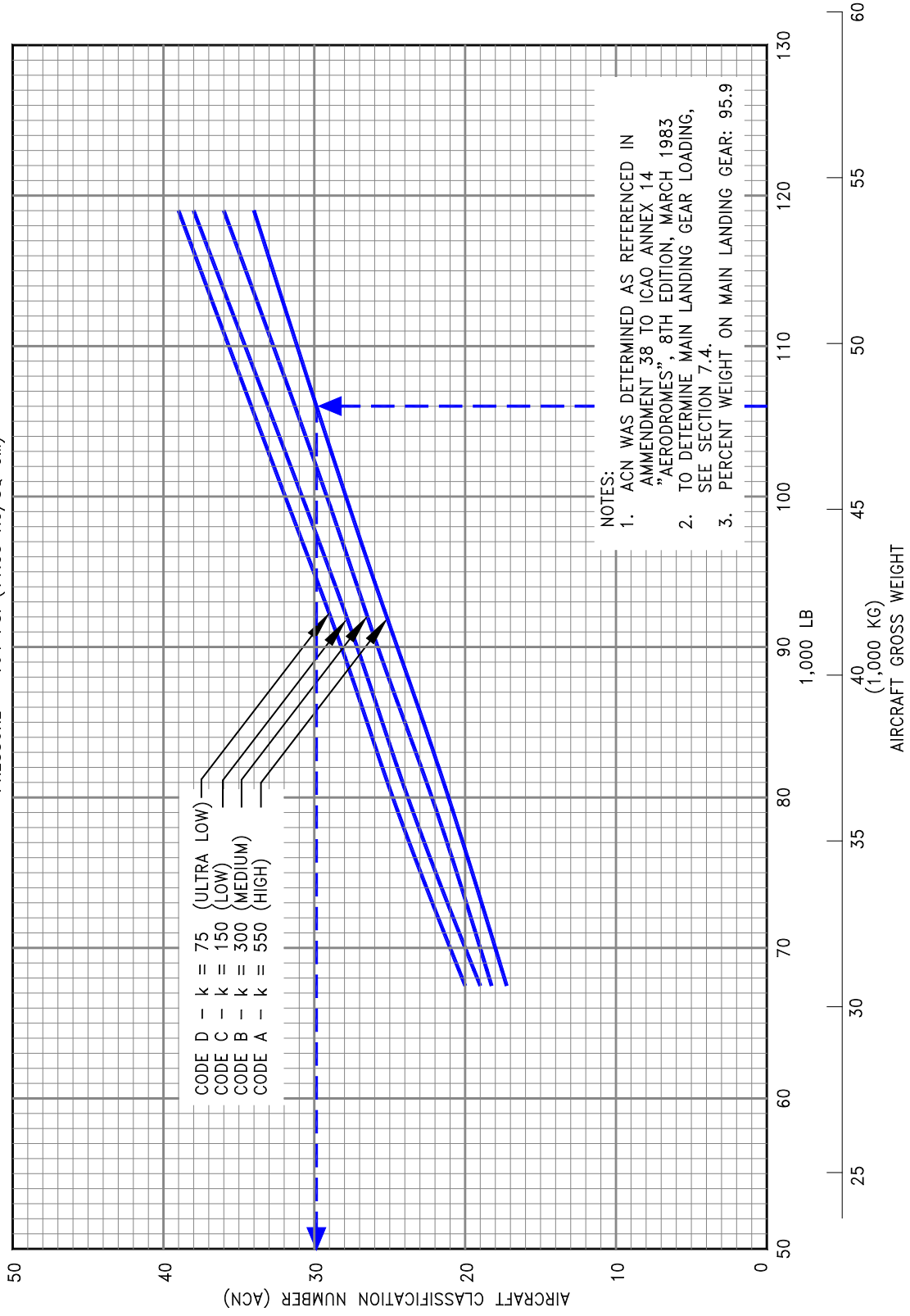

7.10.5 AIRCRAFT CLASSIFICATION NUMBER - RIGID PAVEMENT - 119,000 LB MTW
 MODEL 717-200

NOTES:
 * TIRES - H41 x 15.0 - 19, 24PR
 * PRESSURE - 164 PSI (11.53 KG/SQ CM)

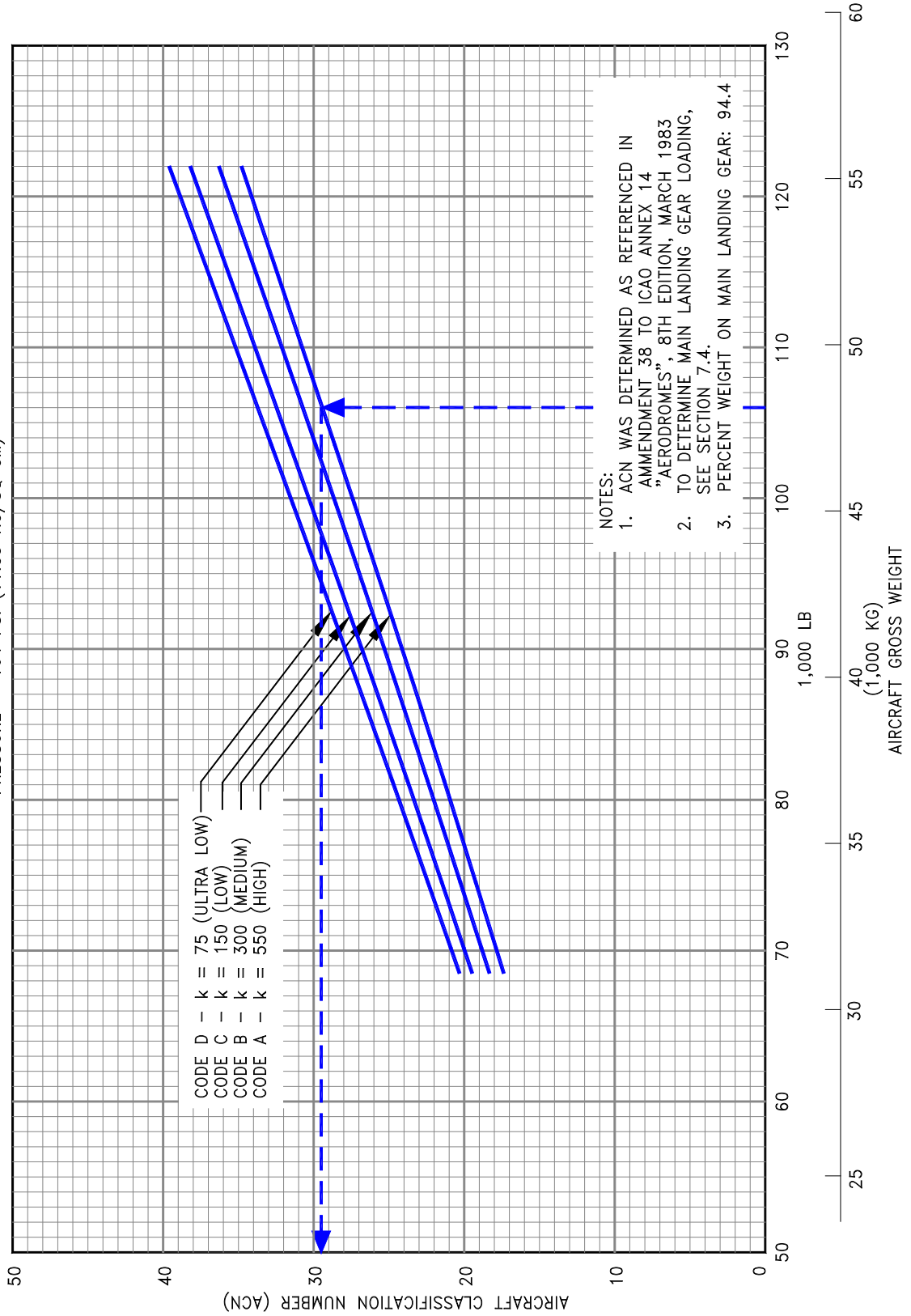

7.10.6 AIRCRAFT CLASSIFICATION NUMBER - RIGID PAVEMENT - 122,000 LB MTW
 MODEL 717-200

D6-58330

REV B

NOVEMBER 2014 93

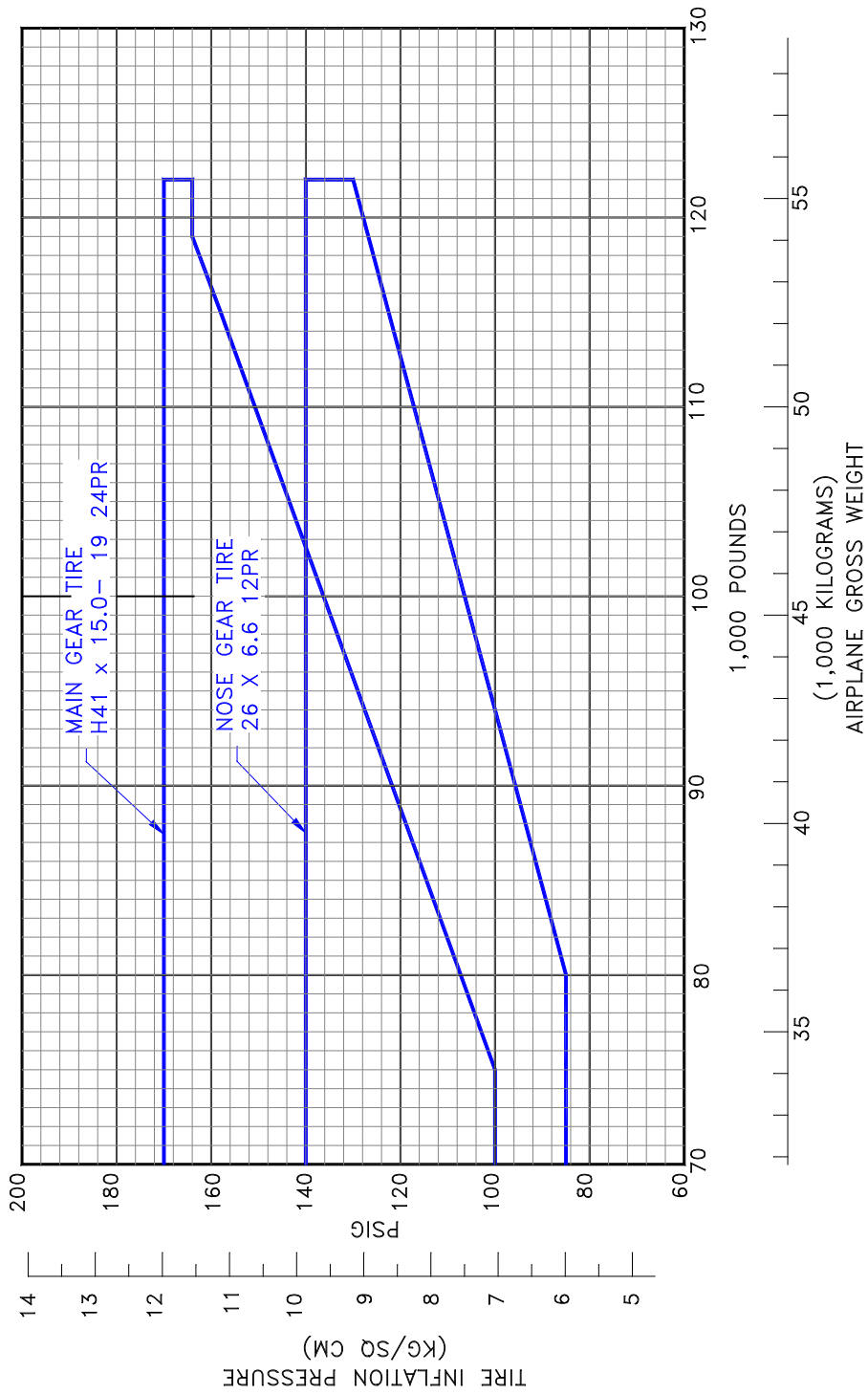

7.11 TIRE INFLATION CHART
MODEL 717-200

8.0 FUTURE 717 DERIVATIVE AIRPLANES

8.0 FUTURE 717 DERIVATIVE AIRPLANES

Development of these derivatives will depend on airline requirements. The impact of airline requirements on airport facilities will be a consideration in the configuration and design of these derivatives.

9.0 SCALED 717-200 DRAWINGS

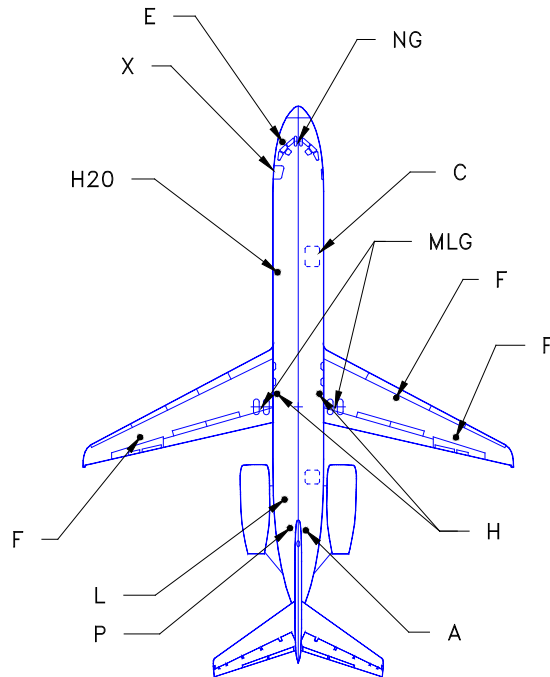
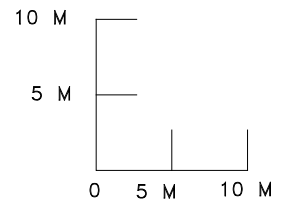

LEGEND

- A AIR CONDITIONING
- C CARGO DOOR
- E ELECTRICAL
- F FUEL
- H HYDRAULIC
- H2O POTABLE WATER
- L LAVATORY
- MLG MAIN LANDING GEAR
- NG NOSE GEAR
- P PNEUMATIC
- X PASSENGER DOOR

NOTE: WHEN PRINTING THIS DRAWING, MAKE SURE TO ADJUST FOR PROPER SCALING

9.1.1 SCALED DRAWING – 1:500
MODEL 717-200

D6-58330

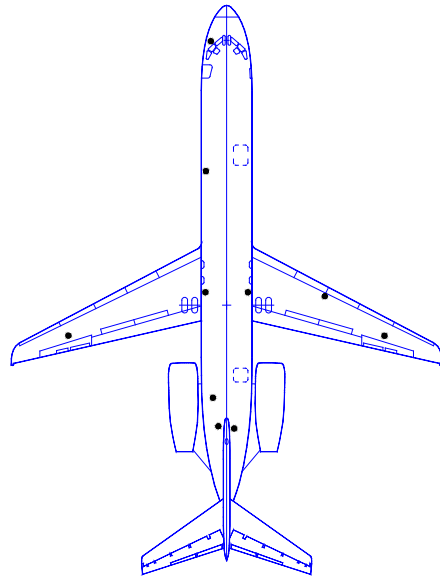
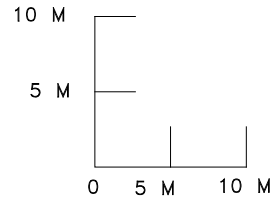

NOTE: WHEN PRINTING THIS DRAWING, MAKE SURE TO ADJUST FOR PROPER SCALING

9.1.2 SCALED DRAWING – 1:500
MODEL 717-200

D6-58330

REV B

NOVEMBER 2014 99