



AGE Code 81205

# **777-200LR / -300ER / -Freighter**

## **Airplane Characteristics for Airport Planning**

DOCUMENT NUMBER:

**D6-58329-2**

REVISION:

**REV F**

REVISION DATE:

**December 2022**

CONTENT OWNER:

**Boeing Commercial Airplanes**

All revisions to this document must be approved by the content owner before release.

Not Subject to US Export Administration Regulations (EAR), (15 C.F.R. Parts 730-774) or US International Traffic in Arms Regulations (ITAR), (22 C.F.R. Parts 120-130).



---

## Revision Record

---

<b>Revision Letter</b>	<b>A</b>
<b>Revision Date</b>	<b>November 2002</b>
<b>Changes in This Revision</b>	
<b>Revision Letter</b>	<b>B</b>
<b>Revision Date</b>	<b>June 2004</b>
<b>Changes in This Revision</b>	
<b>Revision Letter</b>	<b>C</b>
<b>Revision Date</b>	<b>December 2007</b>
<b>Changes in This Revision</b>	
<b>Revision Letter</b>	<b>D</b>
<b>Revision Date</b>	<b>August 2009</b>
<b>Changes in This Revision</b>	
<b>Revision Letter</b>	<b>E</b>
<b>Revision Date</b>	<b>April 2015</b>
<b>Changes in This Revision</b>	Document converted to new format Updated contact data Minor corrections.
<b>Revision Letter</b>	<b>F</b>
<b>Revision Date</b>	<b>December 2022</b>
<b>Changes in This Revision</b>	Section 6: Updated Jet Engine Exhaust Velocity and Temperature Contours, Inlet Hazard Areas Section 7: Added ACR/PCR Data

---

---

## Table of Contents

1.0	SCOPE AND INTRODUCTION .....	1-1
1.1	SCOPE .....	1-1
1.2	INTRODUCTION .....	1-1
1.3	A BRIEF DESCRIPTION OF THE 777 FAMILY OF AIRPLANES.....	1-2
2.0	AIRPLANE DESCRIPTION.....	2-1
2.1	GENERAL CHARACTERISTICS .....	2-1
2.1.1	General Characteristics: Model 777-200LR, -300ER, 777F .....	2-2
2.2	GENERAL DIMENSIONS .....	2-3
2.2.1	General Dimensions: Model 777-200LR .....	2-3
2.2.2	General Dimensions: Model 777-300ER .....	2-4
2.2.3	General Dimensions: Model 777F .....	2-5
2.3	GROUND CLEARANCES .....	2-6
2.3.1	Ground Clearances: Model 777-200LR .....	2-6
2.3.2	Ground Clearances: Model 777-300ER .....	2-7
2.3.3	Ground Clearances: Model 777 Freighter .....	2-8
2.4	INTERIOR ARRANGEMENTS .....	2-9
2.4.1	Typical Interior Arrangements: Model 777-200LR, Typical Two-Class Configurations .....	2-9
2.4.2	Typical Interior Arrangements: Model 777-200LR, Typical Three-Class Configurations .....	2-10
2.4.3	Typical Interior Arrangements: Model 777-300ER, Typical Two-Class Configurations .....	2-11
2.4.4	Typical Interior Arrangements: Model 777-300ER, Typical Three-Class Configurations .....	2-12
2.5	CABIN CROSS SECTIONS .....	2-13
2.5.1	Cabin Cross-Sections: Model 777-200LR, -300ER, First & Business Class Seats .....	2-13
2.5.2	Cabin Cross-Sections: Model 777-200LR, -300ER, Business and Economy Class Seats .....	2-14
2.6	LOWER CARGO COMPARTMENTS .....	2-15
2.6.1	Lower Cargo Compartments: Model 777-200LR, -300ER, Containers and Bulk Cargo .....	2-15
2.6.2	Lower Cargo Compartments: Model 777-200LR, 777F, Optional Aft Large Cargo Door .....	2-16
2.6.3	Lower Cargo Compartments: Model 777-300ER, Optional Aft Large Cargo Door .....	2-17
2.6.4	Main Deck Cargo: Model 777F .....	2-18
2.7	DOOR CLEARANCES .....	2-19
2.7.1	Door Clearances: Model 777-200LR, -300ER, 777F, Main Entry Door Locations .....	2-19

---

2.7.2	Door Clearances: Model 777-200LR, -300ER, 777F, Main Entry Door No 1.....	2-20
2.7.3	Door Clearances: Model 777-200LR, -300ER, Main Entry Door No 2, and No 3. ....	2-21
2.7.4	Door Clearances: Model 777-200LR, -300ER, Main Entry Door No 4, or No 5.....	2-22
2.7.5	Door Clearances: Model 777-200LR, -300ER, Cargo Door Locations .....	2-23
2.7.6	Door Clearances: Model 777F, Cargo Door Locations .....	2-24
2.7.7	Door Clearances: Model 777-200LR, -300ER, 777F, Forward Cargo Door.....	2-25
2.7.8	Door Clearances: Model 777-200LR, -300ER, Small Aft Cargo Door.....	2-26
2.7.9	Door Clearances: Model 777-200LR, -300ER, 777F, Bulk Cargo Door.....	2-27
3.0	AIRPLANE PERFORMANCE .....	3-1
3.1	GENERAL INFORMATION.....	3-1
3.2	PAYLOAD/RANGE FOR LONG RANGE CRUISE FOR 0.84 MACH CRUISE .....	3-2
3.2.1	Payload/Range for 0.84 Mach Cruise: Model 777-200LR (GE90-100 Series Engines).....	3-2
3.2.2	Payload/Range for 0.84 Mach Cruise: Model 777-300ER (GE90-115BL Engines) .....	3-3
3.2.3	Payload/Range for 0.84 Mach Cruise: Model 777F (GE90-100 Series Engines).....	3-4
3.3	F.A.R. TAKEOFF RUNWAY LENGTH REQUIREMENTS.....	3-5
3.3.1	F.A.R. Takeoff Runway Length Requirements - Standard Day: Model 777-200LR (GE90-100B1L Engines).....	3-5
3.3.2	F.A.R. Takeoff Runway Length Requirements - Standard Day + 27°F (STD + 15°C): Model 777-200LR (GE90-110B1L Engines).....	3-6
3.3.3	F.A.R. Takeoff Runway Length Requirements - Standard Day + 49°F (STD + 27°C): Model 777-200LR (GE90-110B1L Engines).....	3-7
3.3.4	F.A.R. Takeoff Runway Length Requirements - Standard Day + 59°F (STD + 33°C): Model 777-200LR (GE90-110B1L Engines).....	3-8
3.3.5	F.A.R. Takeoff Runway Length Requirements - Standard Day: Model 777-200LR (GE90-115BL Engines).....	3-9
3.3.6	F.A.R. Takeoff Runway Length Requirements - Standard Day + 27°F (STD + 15°C): Model 777-200LR (GE90-115BL Engines).....	3-10
3.3.7	F.A.R. Takeoff Runway Length Requirements - Standard Day + 49°F (STD + 27°C): Model 777-200LR (GE90-115BL Engines).....	3-11
3.3.8	F.A.R. Takeoff Runway Length Requirements - Standard Day + 59°F (STD + 33°C): Model 777-200LR (GE90-115BL Engines).....	3-12



---

3.3.9	F.A.R. Takeoff Runway Length Requirements - Standard Day: Model 777-300ER (GE90-115BL Engines).....	3-13
3.3.10	F.A.R. Takeoff Runway Length Requirements - Standard Day + 27°F (STD + 15°C): Model 777-300ER (GE90-115BL Engines).....	3-14
3.3.11	F.A.R. Takeoff Runway Length Requirements - Standard Day + 49°F (STD + 27°C): Model 777-300ER (GE90-115BL Engines).....	3-15
3.3.12	F.A.R. Takeoff Runway Length Requirements - Standard Day + 59°F (STD + 33°C): Model 777-300ER (GE90-115BL Engines).....	3-16
3.3.13	F.A.R. Takeoff Runway Length Requirements - Standard Day: Model 777F (GE90-110B1L Engines).....	3-17
3.3.14	F.A.R. Takeoff Runway Length Requirements - Standard Day + 27°F (STD + 15°C): Model 777F (GE90-110B1L Engines).....	3-18
3.3.15	F.A.R. Takeoff Runway Length Requirements - Standard Day + 49°F (STD + 27°C): Model 777F (GE90-110B1L Engines).....	3-19
3.3.16	F.A.R. Takeoff Runway Length Requirements - Standard Day + 59°F (STD + 33°C): Model 777F (GE90-110B1L Engines).....	3-20
3.3.17	F.A.R. Takeoff Runway Length Requirements - Standard Day: Model 777F (GE90-115BL Engines).....	3-21
3.3.18	F.A.R. Takeoff Runway Length Requirements - Standard Day + 27°F (STD + 15°C): Model 777F (GE90-115BL Engines).....	3-22
3.3.19	F.A.R. Takeoff Runway Length Requirements - Standard Day + 49°F (STD + 27°C): Model 777F (GE90-115BL Engines).....	3-23
3.3.20	F.A.R. Takeoff Runway Length Requirements - Standard Day + 59°F (STD + 33°C): Model 777F (GE90-115BL Engines).....	3-24
3.4	F.A.R. LANDING RUNWAY LENGTH REQUIREMENTS .....	3-25
3.4.1	F.A.R. Landing Runway Length Requirements - Flaps 25: Model 777-200LR (GE90-110B1L Engines).....	3-25
3.4.2	F.A.R. Landing Runway Length Requirements - Flaps 30: Model 777-200LR (GE90-110B1L Engines).....	3-26
3.4.3	F.A.R. Landing Runway Length Requirements - Flaps 25: Model 777-200LR (GE90-115BL Engines).....	3-27
3.4.4	F.A.R. Landing Runway Length Requirements - Flaps 30: Model 777-200LR (GE90-115BL Engines).....	3-28
3.4.5	F.A.R. Landing Runway Length Requirements - Flaps 25: Model 777-300ER (GE90-115BL Engines).....	3-29
3.4.6	F.A.R. Landing Runway Length Requirements - Flaps 30: Model 777-300ER (GE90-115BL Engines).....	3-30
3.4.7	F.A.R. Landing Runway Length Requirements - Flaps 25: Model 777F (GE90-110B1L Engines).....	3-31
3.4.8	F.A.R. Landing Runway Length Requirements - Flaps 30: Model 777F (GE90-110B1L Engines).....	3-32
3.4.9	F.A.R. Landing Runway Length Requirements - Flaps 25: Model 777F (GE90-115BL Engines).....	3-33

---

3.4.10	F.A.R. Landing Runway Length Requirements - Flaps 30: Model 777F (GE90-115BL Engines) .....	3-34
4.0	GROUND MANEUVERING .....	4-1
4.1	GENERAL INFORMATION.....	4-1
4.2	TURNING RADII .....	4-3
4.2.1	Turning Radii – No Slip Angle: Model 777-200LR, 777F .....	4-3
4.2.2	Turning Radii – No Slip Angle: Model 777-300ER .....	4-4
4.3	CLEARANCE RADII: MODEL 777-200LR, -300ER, 777F .....	4-5
4.4	VISIBILITY FROM COCKPIT IN STATIC POSITION: MODEL 777-200LR, -300ER, 777F.....	4-6
4.5	RUNWAY AND TAXIWAY TURN PATHS .....	4-7
4.5.1	Runway and Taxiway Turn Paths - Runway-to-Taxiway, More Than 90 Degrees: Model 777-200LR, -300ER, 777F .....	4-7
4.5.2	Runway and Taxiway Turn Paths - Runway-to-Taxiway, 90 Degrees: Model 777-200LR, -300ER, 777F .....	4-8
4.5.3	Runway and Taxiway Turn Paths - Taxiway-to-Taxiway, 90 Degrees, Nose Gear Tracks Centerline: Model 777-200LR, -300ER, 777F .....	4-9
4.5.4	Runway and Taxiway Turn Paths - Taxiway-to-Taxiway, 90 Degrees, Cockpit Tracks Centerline: Model 777-200LR, -300ER, 777F.....	4-10
4.5.5	Runway and Taxiway Turn Paths - Taxiway-to-Taxiway, 90 Degrees, Judgmental Oversteering: Model 777-200LR, -300ER, 777F.....	4-11
4.6	RUNWAY HOLDING BAY: MODEL 777-200LR, -300ER, 777F .....	4-12
5.0	TERMINAL SERVICING .....	5-1
5.1	AIRPLANE SERVICING ARRANGEMENT - TYPICAL TURNAROUND .....	5-2
5.1.1	Airplane Servicing Arrangement - Typical Turnaround: Model 777-200 / -200ER / -200LR .....	5-2
5.1.2	Airplane Servicing Arrangement - Typical Turnaround: Model 777-300 / -300ER.....	5-3
5.1.3	Airplane Servicing Arrangement - Typical Turnaround: Model 777F.....	5-4
5.2	TERMINAL OPERATIONS - TURNAROUND STATION .....	5-5
5.2.1	Terminal Operations - Turnaround Station: Model 777-200LR .....	5-5
5.2.2	Terminal Operations - Turnaround Station: Model 777-300ER .....	5-6
5.2.3	Terminal Operations - Turnaround Station: Model 777F .....	5-7
5.3	TERMINAL OPERATIONS - EN ROUTE STATION.....	5-8
5.3.1	Terminal Operations - En Route Station: Model 777-200 / -200ER / -200LR .....	5-8
5.3.2	Terminal Operations - En Route Station: Model 777-300 / -300ER .....	5-9

---

5.4	GROUND SERVICING CONNECTIONS.....	5-10
5.4.1	Ground Service Connections: Model 777-200LR.....	5-10
5.4.2	Ground Service Connections: Model 777-300ER.....	5-11
5.4.3	Ground Service Connections: Model 777F.....	5-12
5.4.4	Ground Service Connections and Capacities: Model 777- 200LR, -300ER, 777F .....	5-13
5.5	ENGINE STARTING PNEUMATIC REQUIREMENTS .....	5-14
5.5.1	Engine Start Pneumatic Requirements - Sea Level: Model 777- 200LR, -300ER .....	5-14
5.6	GROUND PNEUMATIC POWER REQUIREMENTS .....	5-15
5.6.1	Ground Pneumatic Power Requirements – Heating, Pull-Up: Model 777-200LR.....	5-15
5.6.2	Ground Pneumatic Power Requirements – Cooling, Pull-Down: Model 777-200LR.....	5-16
5.6.3	Ground Conditioned Air Requirements – Heating, Pull-Up: Model 777-300ER .....	5-17
5.6.4	Ground Conditioned Air Requirements – Cooling, Pull-Down: Model 777-300ER.....	5-18
5.6.5	Ground Conditioned Air Requirements – Heating, Pull-Up: Model 777F .....	5-19
5.6.6	Ground Conditioned Air Requirements – Cooling, Pull-Down: Model 777F .....	5-20
5.7	CONDITIONED AIR REQUIREMENTS .....	5-21
5.7.1	Total Ground Cart Flow – Ground Cart Supply Temperature: Model 777F .....	5-21
5.7.2	Conditioned Air Flow Requirements - Steady State Airflow: Model 777-200LR, -300ER .....	5-22
5.7.3	Conditioned Air Flow Requirements - Steady State Airflow: Model 777F .....	5-23
5.7.4	Air Conditioning Gauge Pressure Requirements - Steady State Airflow: Model 777-200LR, -300ER.....	5-24
5.7.5	Conditioned Air Flow Requirements - Steady State BTU’s: Model 777-200LR, -300ER.....	5-25
5.7.6	Conditioned Air Flow Requirements - Steady State BTU’s: Model 777F .....	5-26
5.7.7	Conditioned Air Flow Requirements - Steady State BTU’s: Model 777F .....	5-27
5.8	GROUND TOWING REQUIREMENTS .....	5-28
5.8.1	Ground Towing Requirements - English and Metric Units: Model 777F .....	5-28
6.0	JET ENGINE WAKE AND NOISE DATA .....	6-1
6.1	JET ENGINE EXHAUST VELOCITIES AND TEMPERATURES .....	6-1

---

6.1.1	Jet Engine Exhaust Velocity Contours – Idle Thrust: Model 777-200LR.....	6-2
6.1.2	Jet Engine Exhaust Velocity Contours - Breakaway Thrust / Single Engine / MTW / 0% Slope: Model 777-200LR.....	6-3
6.1.3	Jet Engine Exhaust Velocity Contours – Breakaway Thrust / Single Engine / MLW / 0% Slope: Model 777-200LR.....	6-4
6.1.4	Jet Engine Exhaust Velocity Contours – Breakaway Thrust / Both Engines / MTW / 1% Slope: Model 777-200LR .....	6-5
6.1.5	Jet Engine Exhaust Velocity Contours – Breakaway Thrust / Both Engines / MTW / 0% Slope: Model 777-200LR .....	6-6
6.1.6	Jet Engine Exhaust Velocity Contours – Takeoff Thrust: Model 777-200LR .....	6-7
6.1.7	Jet Engine Exhaust Velocity Contours – Idle Thrust: Model 777-300ER.....	6-8
6.1.8	Jet Engine Exhaust Velocity Contours – Breakaway Thrust / Single Engine / 0% Slope / MTW: Model 777-300ER.....	6-9
6.1.9	Jet Engine Exhaust Velocity Contours – Breakaway Thrust / Single Engine / 0% Slope / MLW: Model 777-300ER.....	6-10
6.1.10	Jet Engine Exhaust Velocity Contours – Breakaway Thrust / Both Engines / 0% Slope / MTW: Model 777-300ER .....	6-11
6.1.11	Jet Engine Exhaust Velocity Contours – Breakaway Thrust / Both Engines / 1% Slope / MTW: Model 777-300ER .....	6-12
6.1.12	Jet Engine Exhaust Velocity Contours – Takeoff Thrust: Model 777-300ER .....	6-13
6.1.13	Inlet Hazard Areas: All Models .....	6-14
6.2	AIRPORT AND COMMUNITY NOISE.....	6-15
7.0	PAVEMENT DATA .....	7-1
7.1	GENERAL INFORMATION.....	7-1
7.2	LANDING GEAR FOOTPRINT: MODEL 777-200LR, -300ER, 777F .....	7-5
7.3	MAXIMUM PAVEMENT LOADS: MODEL 777-200LR, -300ER, 777F .....	7-6
7.4	LANDING GEAR LOADING ON PAVEMENT .....	7-7
7.4.1	Landing Gear Loading on Pavement: Model 777-200LR.....	7-7
7.4.2	Landing Gear Loading on Pavement: Model 777-300ER.....	7-8
7.4.3	Landing Gear Loading on Pavement: Model 777F .....	7-9
7.5	FLEXIBLE PAVEMENT REQUIREMENTS - U.S. ARMY CORPS OF ENGINEERS METHOD S-77-1 .....	7-10
7.5.1	Flexible Pavement Requirements - U.S. Army Corps of Engineers Design Method (S-77-1): Model 777-200LR, 777F .....	7-11
7.5.2	Flexible Pavement Requirements - U.S. Army Corps of Engineers Design Method (S-77-1): Model 777-300ER .....	7-12
7.6	FLEXIBLE PAVEMENT REQUIREMENTS - LCN CONVERSION.....	7-13

---

---

7.6.1	Flexible Pavement Requirements - LCN Method: Model 777-200LR, 777F .....	7-14
7.6.2	Flexible Pavement Requirements - LCN Method: Model 777-300ER.....	7-15
7.7	RIGID PAVEMENT REQUIREMENTS - PORTLAND CEMENT ASSOCIATION DESIGN METHOD .....	7-16
7.7.1	Rigid Pavement Requirements - Portland Cement Association Design Method: Model 777-200LR, 777F.....	7-17
7.7.2	Rigid Pavement Requirements - Portland Cement Association Design Method: Model 777-300ER.....	7-18
7.8	RIGID PAVEMENT REQUIREMENTS - LCN CONVERSION .....	7-19
7.8.1	Radius of Relative Stiffness (Reference: Portland Cement Association).....	7-20
7.8.2	Rigid Pavement Requirements - LCN Conversion: Model 777-200LR, 777F .....	7-21
7.8.3	Rigid Pavement Requirements - LCN Conversion: Model 777-300ER.....	7-22
7.9	RIGID PAVEMENT REQUIREMENTS - FAA DESIGN METHOD .....	7-23
7.9.1	Rigid Pavement Requirements: Model 777-200LR, -300ER, 777F ....	7-24
7.10	ACN/PCN REPORTING SYSTEM - FLEXIBLE AND RIGID PAVEMENTS .....	7-25
7.10.1	Aircraft Classification Number - Flexible Pavement: Model 777F .....	7-26
7.10.2	Aircraft Classification Number - Flexible Pavement: Model 777-200LR .....	7-27
7.10.3	Aircraft Classification Number - Flexible Pavement: Model 777-300ER .....	7-28
7.10.4	Aircraft Classification Number - Rigid Pavement: Model 777F .....	7-29
7.10.5	Aircraft Classification Number - Rigid Pavement: Model 777-200LR .....	7-30
7.10.6	Aircraft Classification Number - Rigid Pavement: Model 777-300ER .....	7-31
7.11	ACR/PCR REPORTING SYSTEM - FLEXIBLE AND RIGID PAVEMENTS .....	7-32
7.11.1	Aircraft Classification Rating - Flexible Pavement: Model 777F.....	7-33
7.11.2	Aircraft Classification Rating - Flexible Pavement: Model 777-200LR.....	7-34
7.11.3	Aircraft Classification Rating - Flexible Pavement: Model 777-300ER.....	7-35
7.11.4	Aircraft Classification Rating - Rigid Pavement: Model 777F.....	7-36
7.11.5	Aircraft Classification Rating - Rigid Pavement: Model 777-200LR.....	7-37
7.11.6	Aircraft Classification Rating - Rigid Pavement: Model 777-300ER.....	7-38

---

8.0	FUTURE 777 DERIVATIVE AIRPLANES.....	8-1
9.0	SCALED 777 DRAWINGS .....	9-1
9.1	MODEL 777-200LR.....	9-2
9.1.1	Scaled Drawings – 1:500: Model 777-200LR .....	9-2
9.1.2	Scaled Drawings – 1:500: Model 777-200LR .....	9-3
9.2	MODEL 777-300ER.....	9-4
9.2.1	Scaled Drawings – 1:500: Model 777-300ER .....	9-4
9.2.2	Scaled Drawings – 1:500: Model 777-300ER .....	9-5
9.3	MODEL 777 FREIGHTER .....	9-6
9.3.1	Scaled Drawings – 1:500: Model 777F .....	9-6
9.3.2	Scaled Drawings – 1:500: Model 777F .....	9-7

---

## 1.0 SCOPE AND INTRODUCTION

### 1.1 SCOPE

This document provides, in a standardized format, airplane characteristics data for general airport planning. Since operational practices vary among airlines, specific data should be coordinated with the using airlines prior to facility design. Boeing Commercial Airplanes should be contacted for any additional information required.

Content of the document reflects the results of a coordinated effort by representatives from the following organizations:

- Aerospace Industries Association
- Airports Council International - North America
- International Industry Working Group
- International Air Transport Association

The airport planner may also want to consider the information presented in the "Commercial Aircraft Design Characteristics – Trends and Growth Projections," for long range planning needs and can be accessed via the following web site:

[www.boeing.com/airports](http://www.boeing.com/airports)

The document is updated periodically and represents the coordinated efforts of the following organizations regarding future aircraft growth trends:

- International Civil Aviation Organization
- International Coordinating Council of Aerospace Industries Associations
- Airports Council International - North American and World Organizations
- International Industry Working Group
- International Air Transport Association

### 1.2 INTRODUCTION

This document conforms to NAS 3601. It provides characteristics of the Boeing Model 777-200LR, 777-300ER and 777-Freighter airplanes for airport planners and operators, airlines, architectural and engineering consultant organizations, and other interested industry agencies. Airplane changes and available options may alter model characteristics. The data presented herein reflect typical airplanes in each model category. Data used is generic in scope and not customer-specific.

---

For additional information contact:

Boeing Commercial Airplanes  
2201 Seal Beach Blvd. M/C: 110-SB02  
Seal Beach, CA 90740-1515  
U.S.A.

Attention: Manager, Airport Compatibility Engineering

Phone: 562-797-1172

Email: [AirportCompatibility@boeing.com](mailto:AirportCompatibility@boeing.com)

### **1.3 A BRIEF DESCRIPTION OF THE 777 FAMILY OF AIRPLANES**

#### **777-200/-200ER Airplane**

The 777-200/-200ER is a twin-engine airplane designed for medium to long range flights. It is powered by advanced high bypass ratio engines. Characteristics unique to the 777 include:

- Two-crew cockpit with digital avionics
- Circular cross-section
- Lightweight aluminum and composite alloys
- Structural carbon brakes
- Six-wheel main landing gears
- Main gear aft axle steering
- High bypass ratio engines
- Fly-by-wire system

#### **777-200LR Airplane**

The 777-200LR is a derivative of the 777-200 airplane and is equipped with raked wingtips to provide additional cruise altitude and range. It is powered by high bypass ratio engines that develop higher thrusts than those used in the 777-200/-200ER airplanes. The 777-200LR has an identical fuselage as the 777-200/-200ER but has a wider wingspan due to raked wingtips.



---

## 777-300 Airplane

The 777-300 is a second-generation derivative of the 777-200. Two body sections are added to the fuselage to provide additional passenger seating and cargo capacity.

## 777-300ER Airplane

The 777-300ER is a derivative of the 777-300 airplane and is equipped with raked wingtips for additional cruise altitude and range. It is powered by high bypass ratio engines that develop higher thrusts than those used in the 777-200/-200ER/-300 airplanes. The 777-300ER has an identical fuselage as the 777-300, but has a wider wingspan due to the raked wingtips.

## 777-Freighter Airplane

The 777-Freighter, newest member of the 777 Family of airplanes, is based on the 777-200LR Worldliner (Longer Range) passenger airplane. The 777-Freighter will fly farther than any other freighter, providing more capacity than any other twin-engine freighter, and will meet QC2 noise standards for maximum accessibility to noise-sensitive airports. The 777-Freighter will share the 777 Family's advanced features of a state-of-the-art flight deck, fly-by-wire design and an advanced wing design, including raked wing tips. The 777-Freighter is powered by the world's most powerful commercial jet engine, General Electric's GE90-110B1L.

The 777-Freighter is designed to integrate smoothly with existing cargo operations and facilitate interlining with 747 freighter fleets. Cargo operators will be able to easily transfer 10-foot-high pallets between the two models via the large main deck cargo door.

## Main Gear Aft Axle Steering

The main gear axle steering is automatically engaged based on the nose gear steering angle. This allows for less tire scrubbing and easier maneuvering into gates with limited parking clearances.

## High Bypass Ratio Engines

The 777 airplane is powered by two high bypass ratio engines. The following table shows the available engine options:

ENGINE MANUFACTURER	ENGINE MODEL	ENGINE THRUST	MAX TAXI WEIGHT (LB)		
			777-200LR	777-300ER	777F
GENERAL ELECTRIC	GE90-110B	110,000 LB	768,000	-	-
	GE90-110B1	110,000 LB	768,000	-	-
	GE90-110B1L	110,000 LB	-	-	768,800
	GE90-115B1	115,300 LB	768,000	777,000	-

---

## **Document Applicability**

This document contains data specific to the 777-200LR, 777-300ER and 777-Freighter.

Data for the 777-200, 777-200ER, and 777-300 airplanes are contained in document D6-58329.

---

## 2.0 AIRPLANE DESCRIPTION

### 2.1 GENERAL CHARACTERISTICS

Maximum Design Taxi Weight (MTW). Maximum weight for ground maneuver as limited by aircraft strength and airworthiness requirements. (It includes weight of taxi and run-up fuel.)

Maximum Design Takeoff Weight (MTOW). Maximum weight for takeoff as limited by aircraft strength and airworthiness requirements. (This is the maximum weight at start of the takeoff run.)

Maximum Design Landing Weight (MLW). Maximum weight for landing as limited by aircraft strength and airworthiness requirements.

Maximum Design Zero Fuel Weight (MZFV). Maximum weight allowed before usable fuel and other specified usable agents must be loaded in defined sections of the aircraft as limited by strength and airworthiness requirements.

Operating Empty Weight (OEW). Weight of structure, powerplant, furnishing systems, unusable fuel and other unusable propulsion agents, and other items of equipment that are considered an integral part of a particular airplane configuration. Also included are certain standard items, personnel, equipment, and supplies necessary for full operations, excluding usable fuel and payload.

Maximum Structural Payload. Maximum design zero fuel weight minus operational empty weight.

Maximum Seating Capacity. The maximum number of passengers specifically certificated or anticipated for certification.

Maximum Cargo Volume. The maximum space available for cargo.

Usable Fuel. Fuel available for aircraft propulsion.

## 2.1.1 General Characteristics: Model 777-200LR, -300ER, 777F

CHARACTERISTICS	UNITS	777-200LR	777-300ER	777-F
MAX DESIGN TAXI WEIGHT	POUNDS	768,000	777,000	768,800
	KILOGRAMS	348,358	352,442	348,722
MAX DESIGN TAKEOFF WEIGHT	POUNDS	766,000	775,000	766,800
	KILOGRAMS	347,452	351,535	347,815
MAX DESIGN LANDING WEIGHT	POUNDS	492,000	554,000	575,000
	KILOGRAMS	223,168	251,290	260,816
MAX DESIGN ZERO FUEL WEIGHT	POUNDS	461,000	524,000	547,000
	KILOGRAMS	209,106	237,683	248,115
TYPICAL SEATING CAPACITY	TWO CLASS	279 (3)	339 (5)	N/A
	THREE CLASS	301 (4)	370 (6)	N/A
MAX CARGO --LOWER DECK	CUBIC FEET	5,656 (1)	7,552 (1)	22,371 (2)
	CUBIC METERS	160.2 (1)	213.8 (1)	633.5 (2)
USABLE FUEL	U.S. GALLONS	47,890	47,890	47,890
	LITERS	181,283	181,283	181,283
	POUNDS	320,863	320,863	320,863
	KILOGRAMS	145,538	145,538	145,538

### NOTES:

1. FWD CARGO = 18 LD3'S AT 158 CU FT EACH.  
AFT CARGO = 14 LD3'S AT 158 CU FT EACH.  
BULK CARGO = 600 CU FT
2. INCLUDES MAIN DECK, FORWARD LOWER LOBE, AND AFT LOWER LOBE
3. 42 FIRST CLASS AND 237 ECONOMY CLASS
4. 16 FIRST CLASS, 58 BUSINESS CLASS AND 227 ECONOMY CLASS
5. 56 FIRST CLASS AND 283 ECONOMY CLASS
6. 12 FIRST CLASS, 42 BUSINESS CLASS AND 316 ECONOMY CLASS

## 2.2 GENERAL DIMENSIONS

### 2.2.1 General Dimensions: Model 777-200LR

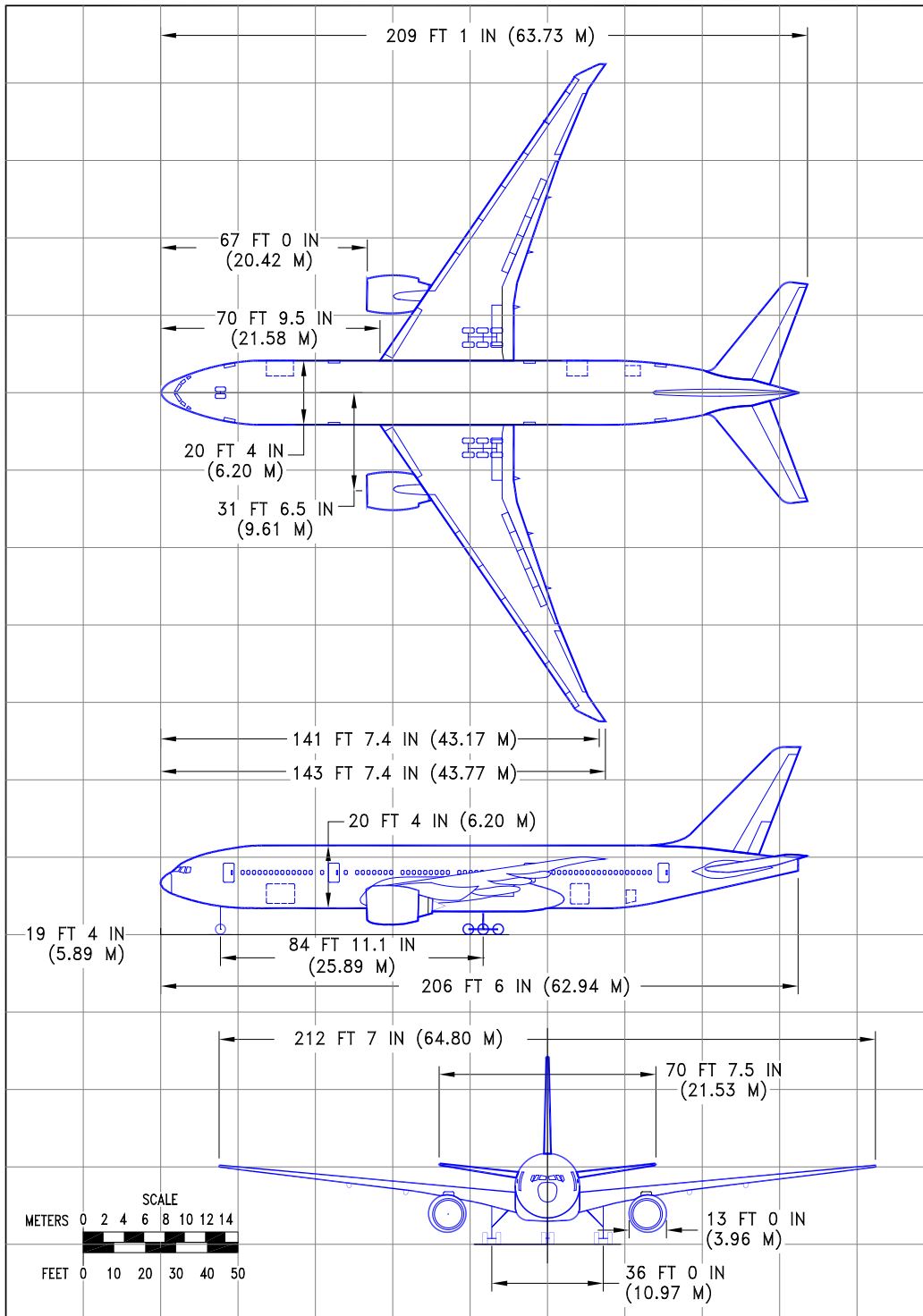

D6-58329-2

REV F

December 2022

2-3

Not Subject to EAR or ITAR.  
Copyright © 2023 Boeing. All Rights Reserved.

## 2.2.2 General Dimensions: Model 777-300ER

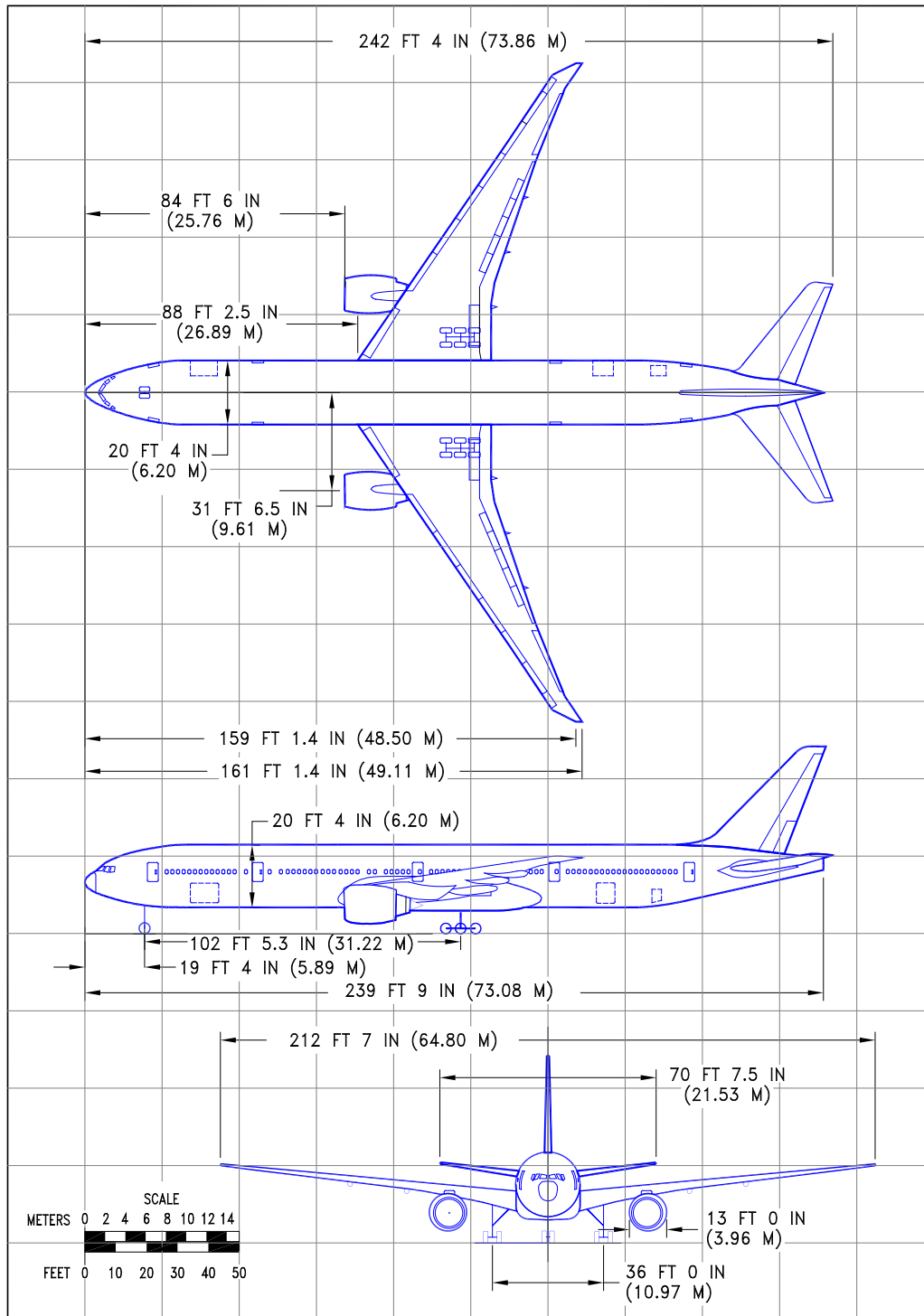

### 2.2.3 General Dimensions: Model 777F

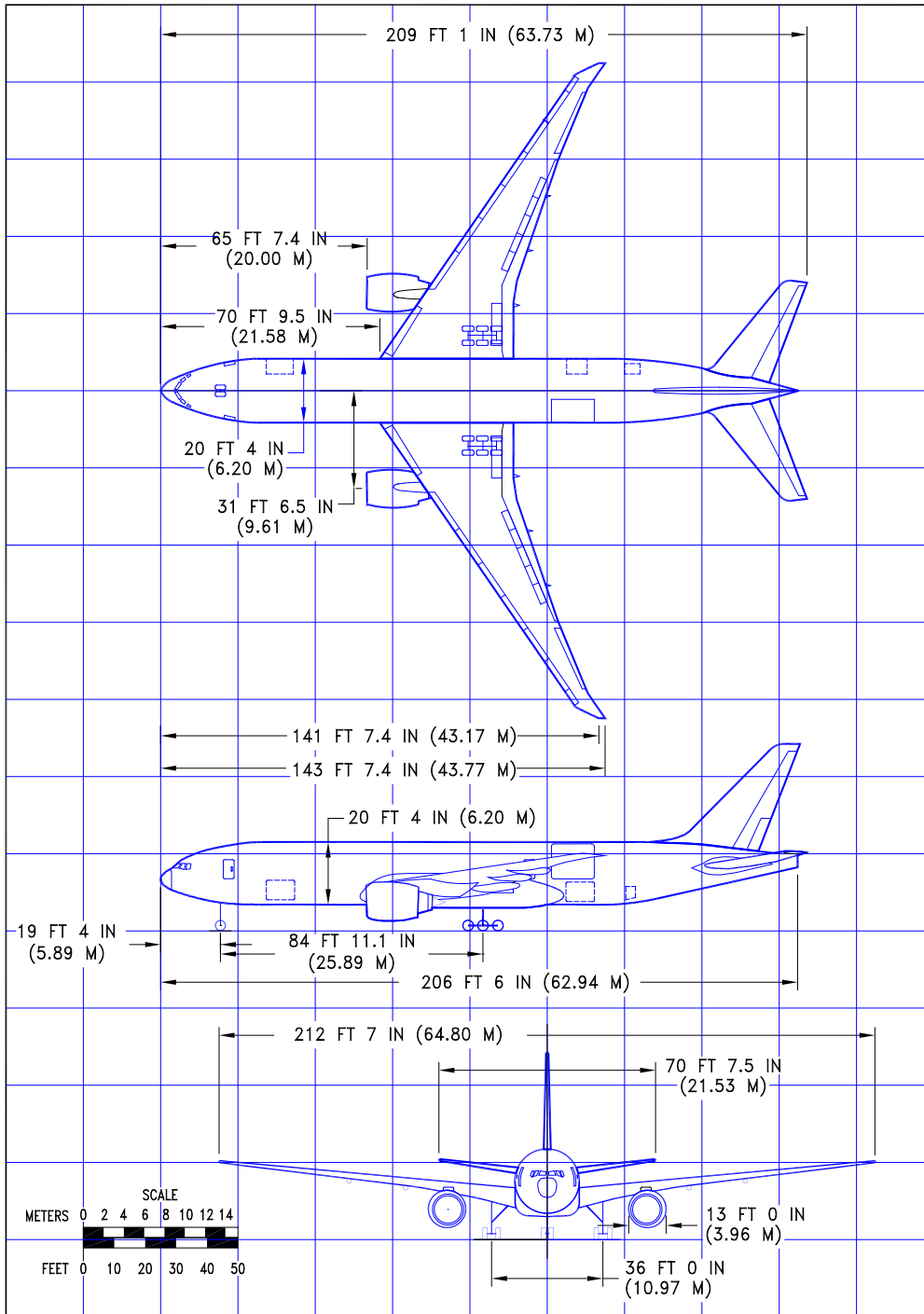

## 2.3 GROUND CLEARANCES

### 2.3.1 Ground Clearances: Model 777-200LR

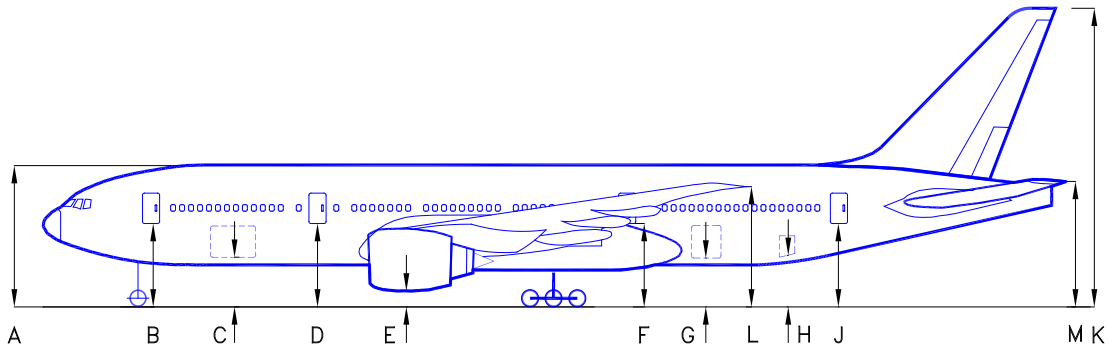

Dimension	MINIMUM*		MAXIMUM*	
	FT - IN	M	FT - IN	M
A	27 - 5	8.36	28 - 7	8.70
B	15 - 5	4.69	16 - 7	5.06
C	9 - 2	2.79	10 - 2	3.11
D	15 - 11	4.85	16 - 10	5.11
E	2 - 4	0.70	2 - 10	0.88
F	16 - 10	5.14	17 - 5	5.30
G (LARGE/SMALL DOOR)	10 - 6	3.19	11 - 9	3.58
H	11 - 2	3.40	11 - 10	3.61
J	17 - 5	5.31	18 - 1	5.52
K	60 - 8	18.48	61 - 6	18.75
L	23 - 6	7.16	24 - 7	7.49
M	26 - 2	8.06	27 - 5	8.34

**NOTES:** VERTICAL CLEARANCES SHOWN OCCUR DURING MAXIMUM VARIATIONS OF AIRPLANE ATTITUDE. COMBINATIONS OF AIRPLANE LOADING AND UNLOADING ACTIVITIES THAT PRODUCE THE GREATEST POSSIBLE VARIATIONS IN ATTITUDE WERE USED TO ESTABLISH THE VARIATIONS SHOWN.

DURING ROUTINE SERVICING, THE AIRPLANE REMAINS RELATIVELY STABLE, PITCH AND ELEVATION CHANGES OCCURRING SLOWLY.

\* NOMINAL DIMENSIONS



## 2.3.2 Ground Clearances: Model 777-300ER

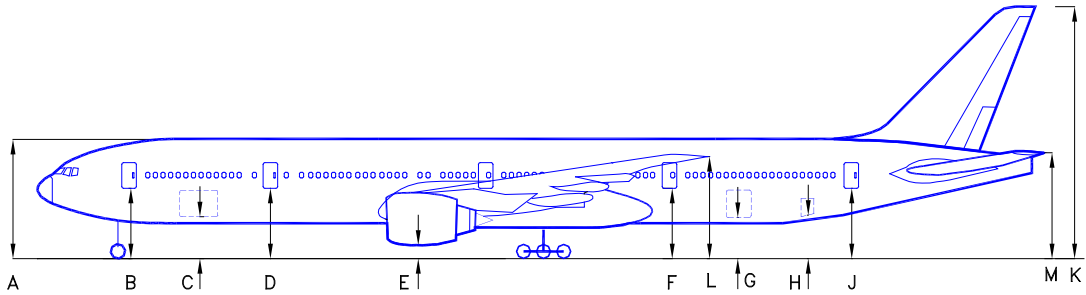

Dimension	MINIMUM*		MAXIMUM*	
	FT - IN	M	FT - IN	M
A	27 - 9	8.46	28 - 10	8.78
B	15 - 9	4.80	16 - 10	5.13
C	9 - 5	2.88	10 - 6	3.19
D	16 - 2	4.92	17 - 1	5.20
E	2 - 5	0.73	3 - 3	0.99
F	16 - 9	5.11	17 - 5	5.32
G (LARGE/SMALL DOOR)	10 - 6	3.19	11 - 9	3.58
H	10 - 11	3.32	12 - 4	3.76
J	17 - 0	5.19	18 - 7	5.66
K	59 - 10	18.24	61 - 10	18.85
L	23 - 11	7.29	25 - 11	7.90
M	25 - 7	7.79	27 - 8	8.43

**NOTES:** VERTICAL CLEARANCES SHOWN OCCUR DURING MAXIMUM VARIATIONS OF AIRPLANE ATTITUDE. COMBINATIONS OF AIRPLANE LOADING AND UNLOADING ACTIVITIES THAT PRODUCE THE GREATEST POSSIBLE VARIATIONS IN ATTITUDE WERE USED TO ESTABLISH THE VARIATIONS SHOWN.

DURING ROUTINE SERVICING, THE AIRPLANE REMAINS RELATIVELY STABLE, PITCH AND ELEVATION CHANGES OCCURRING SLOWLY.

\* NOMINAL DIMENSIONS ROUNDED TO NEAREST INCH AND NEAREST CENTIMETER

### 2.3.3 Ground Clearances: Model 777 Freighter

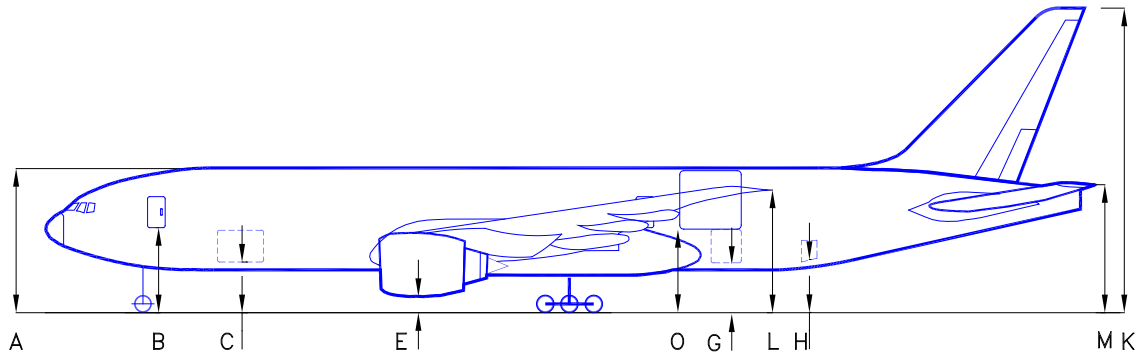

Dimension	MINIMUM*		MAXIMUM*	
	FT - IN	M	FT - IN	M
A	27 - 9	8.46	28 - 10	8.78
B	15 - 3	4.65	16 - 10	5.13
C	9 - 5	2.88	10 - 6	3.19
E	2 - 7	0.79	3 - 3	0.99
G (LARGE/SMALL DOOR)	10 - 10	3.32	11 - 8	3.56
H	10 - 11	3.32	12 - 4	3.76
K	60 - 11	18.58	62 - 4	18.99
L	23 - 11	7.29	25 - 11	7.90
M	26 - 10	8.17	28 - 3	8.60
O	17 - 4	5.29	18 - 2	5.53

**NOTES:** VERTICAL CLEARANCES SHOWN OCCUR DURING MAXIMUM VARIATIONS OF AIRPLANE ATTITUDE. COMBINATIONS OF AIRPLANE LOADING AND UNLOADING ACTIVITIES THAT PRODUCE THE GREATEST POSSIBLE VARIATIONS IN ATTITUDE WERE USED TO ESTABLISH THE VARIATIONS SHOWN.

DURING ROUTINE SERVICING, THE AIRPLANE REMAINS RELATIVELY STABLE, PITCH AND ELEVATION CHANGES OCCURRING SLOWLY.

\* NOMINAL DIMENSIONS ROUNDED TO NEAREST INCH AND NEAREST CENTIMETER

## 2.4 INTERIOR ARRANGEMENTS

### 2.4.1 Typical Interior Arrangements: Model 777-200LR, Typical Two-Class Configurations

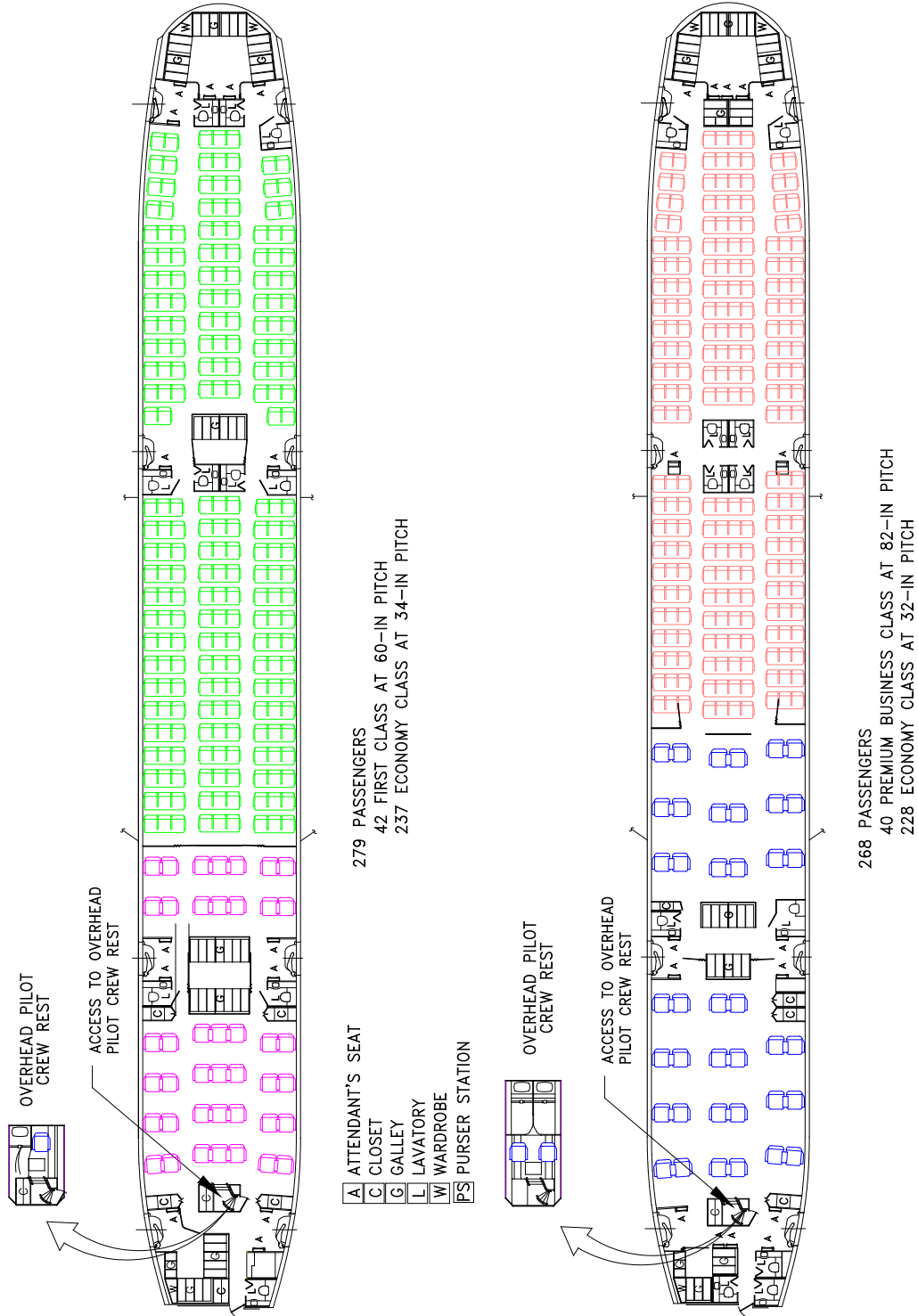

## 2.4.2 Typical Interior Arrangements: Model 777-200LR, Typical Three-Class Configurations

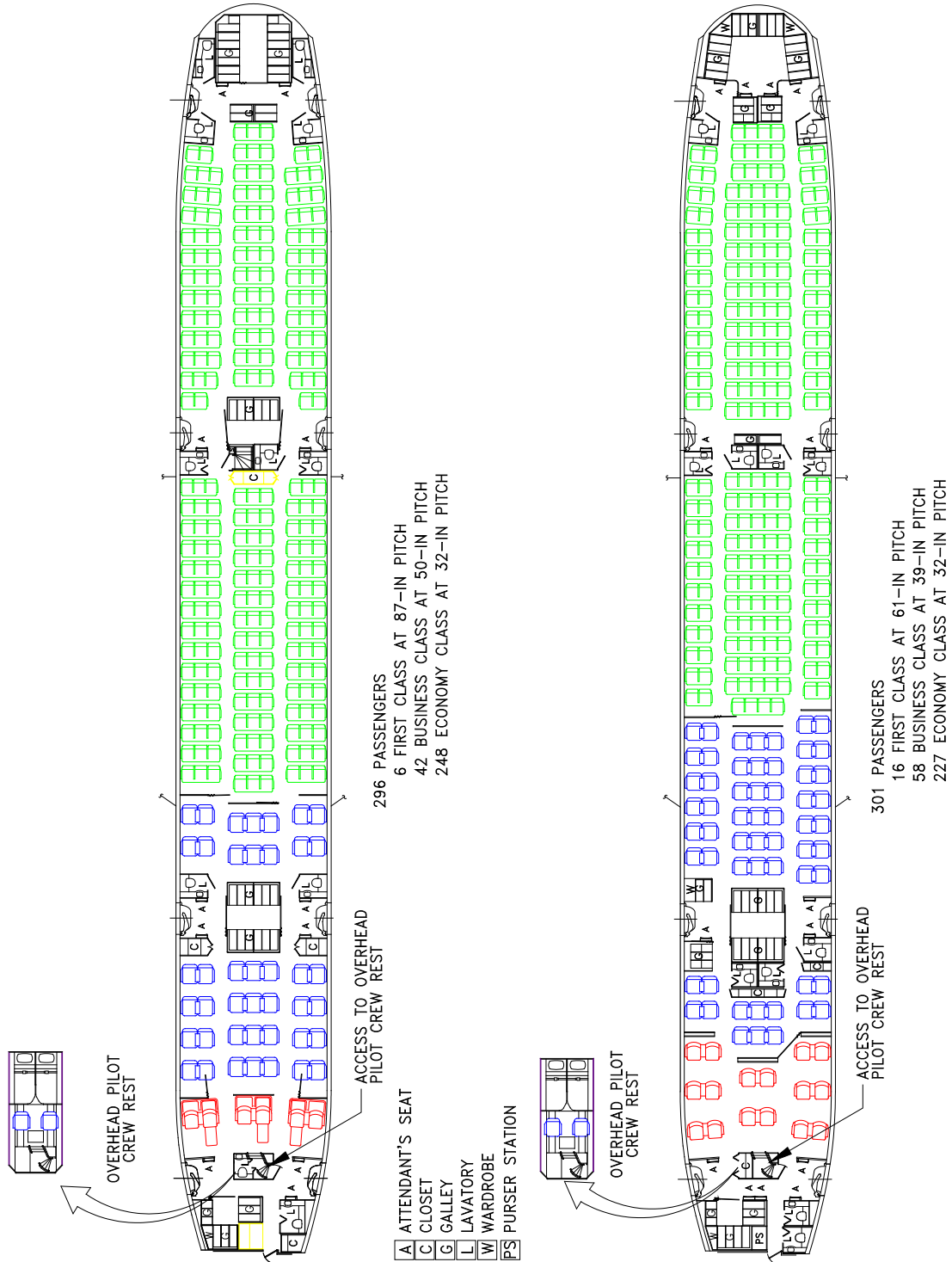

D6-58329-2

## 2.4.3 Typical Interior Arrangements: Model 777-300ER, Typical Two-Class Configurations

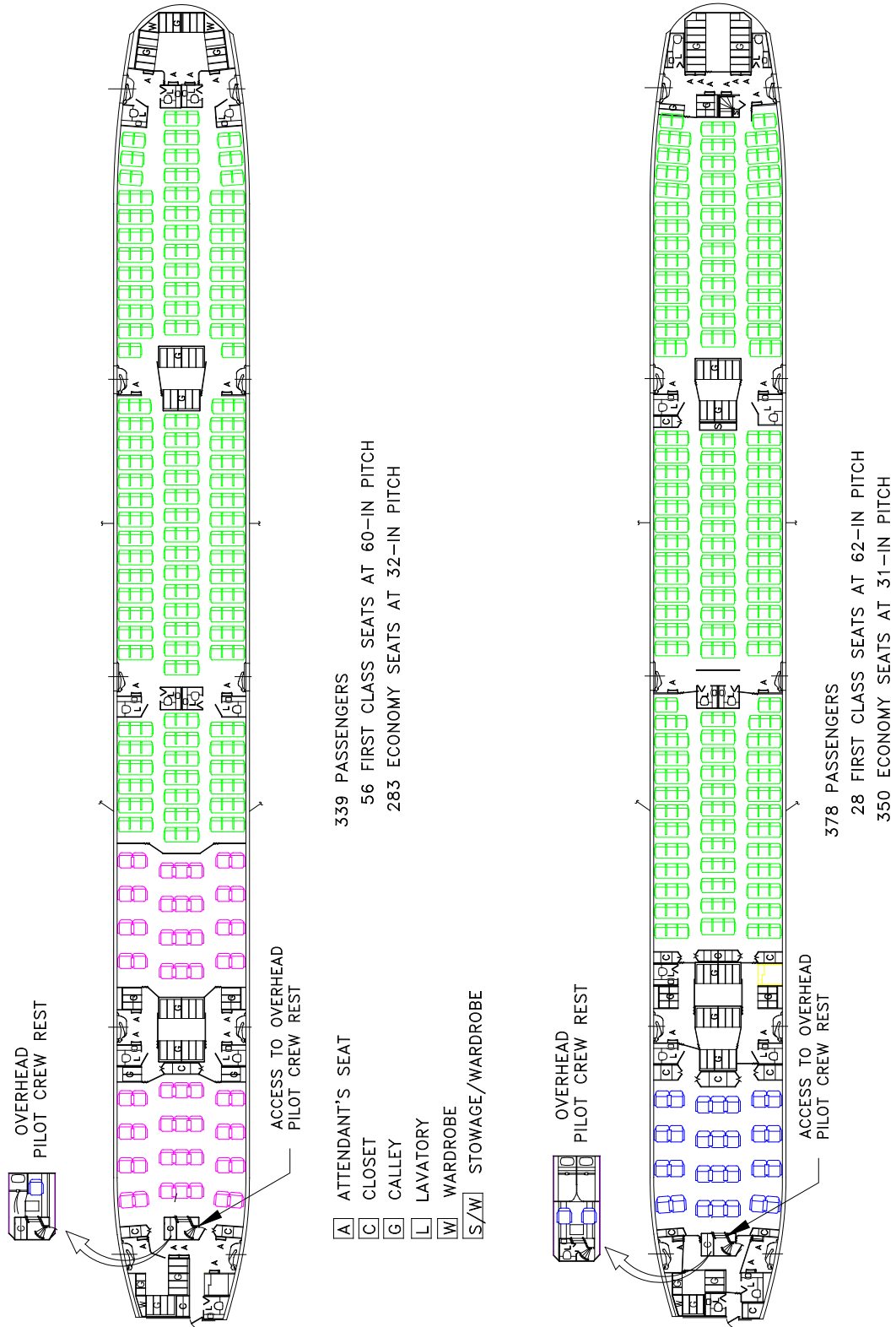

D6-58329-2

## 2.4.4 Typical Interior Arrangements: Model 777-300ER, Typical Three-Class Configurations

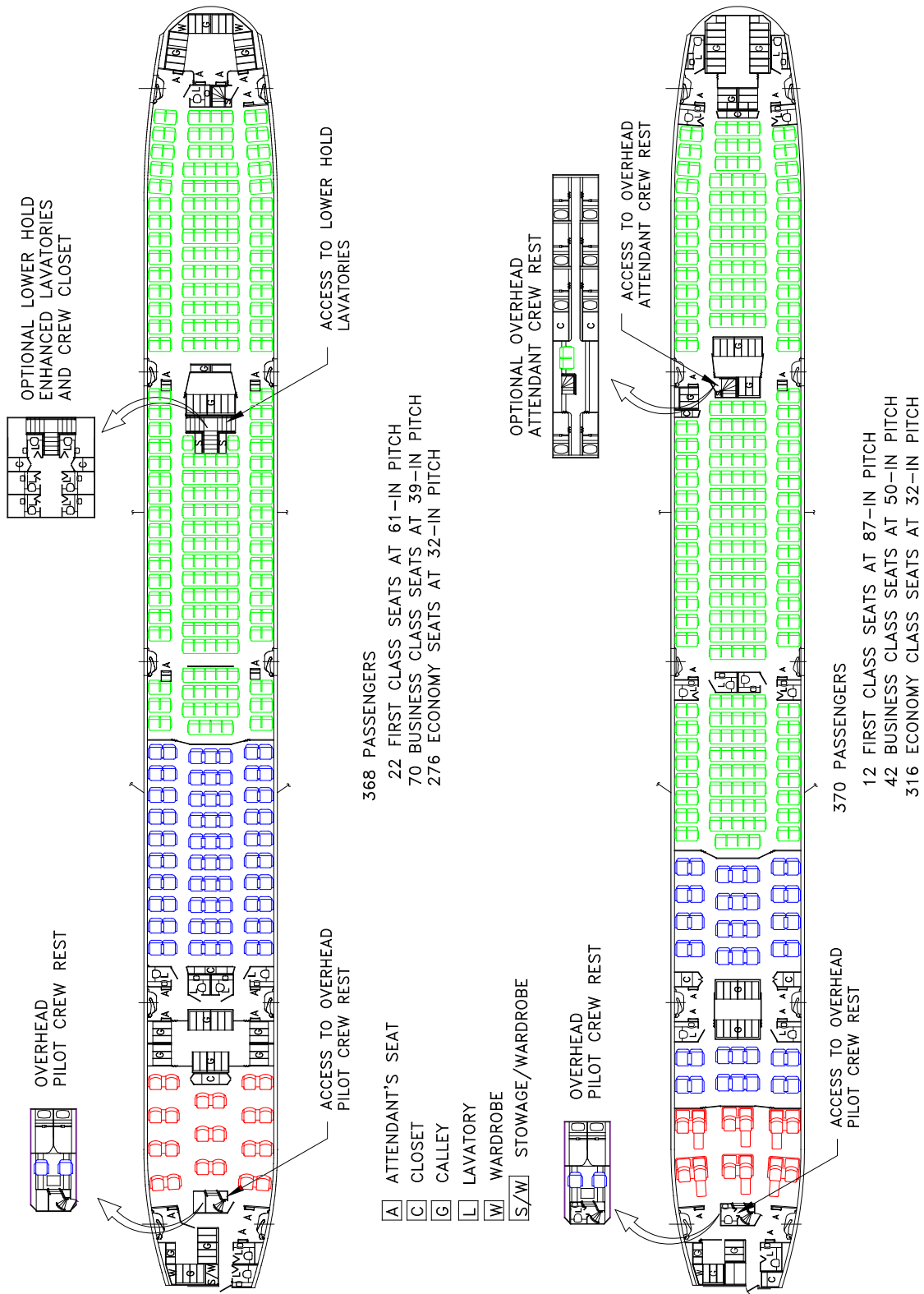

D6-58329-2

---

## 2.5 CABIN CROSS SECTIONS

### 2.5.1 Cabin Cross-Sections: Model 777-200LR, -300ER, First & Business Class Seats

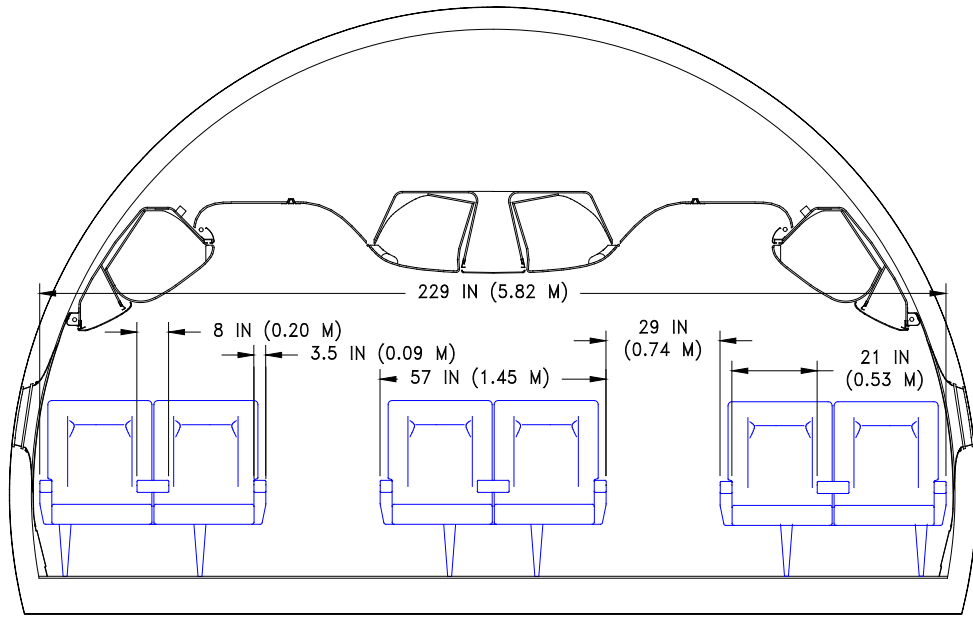

FIRST CLASS SEATING  
SIX ABREAST

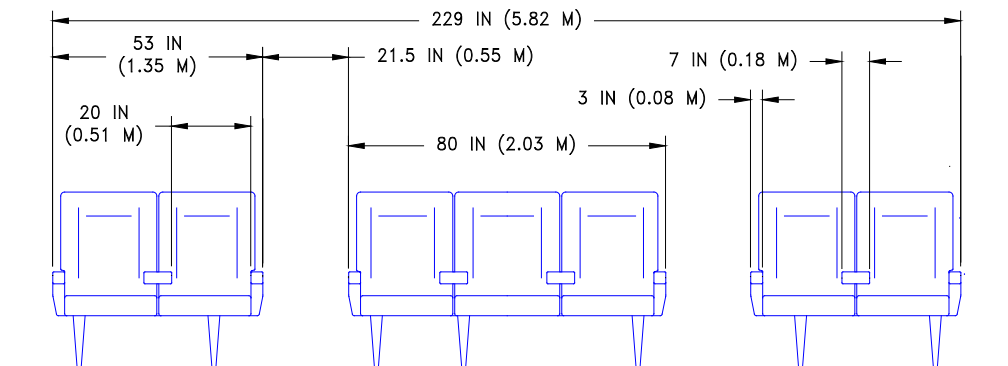

BUSINESS CLASS SEATING  
SEVEN-ABREAST

## 2.5.2 Cabin Cross-Sections: Model 777-200LR, -300ER, Business and Economy Class Seats

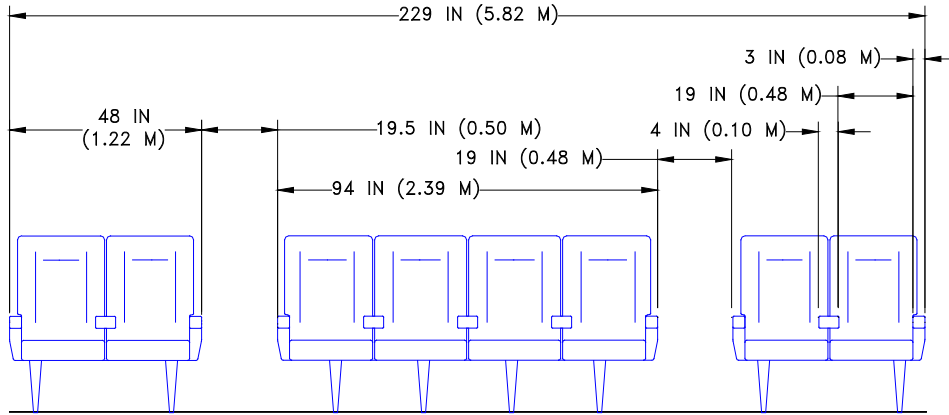

BUSINESS CLASS SEATING  
EIGHT-ABREAST

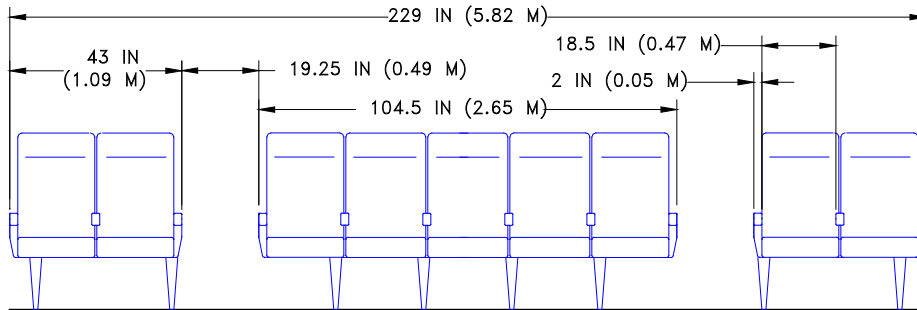

ECONOMY CLASS SEATING  
NINE-ABREAST

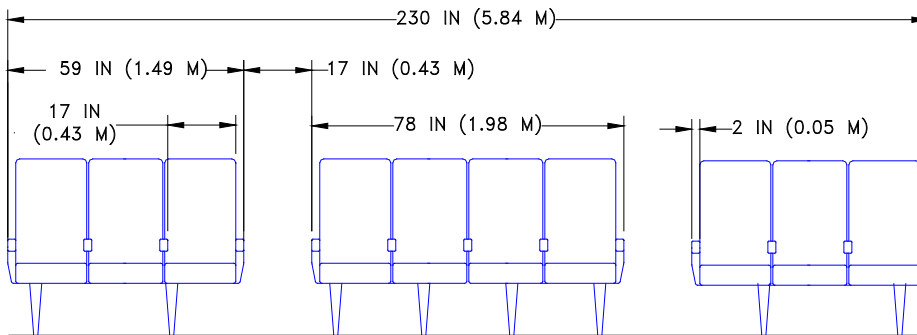

ECONOMY CLASS SEATING  
TEN-ABREAST



## 2.6 LOWER CARGO COMPARTMENTS

### 2.6.1 Lower Cargo Compartments: Model 777-200LR, -300ER, Containers and Bulk Cargo

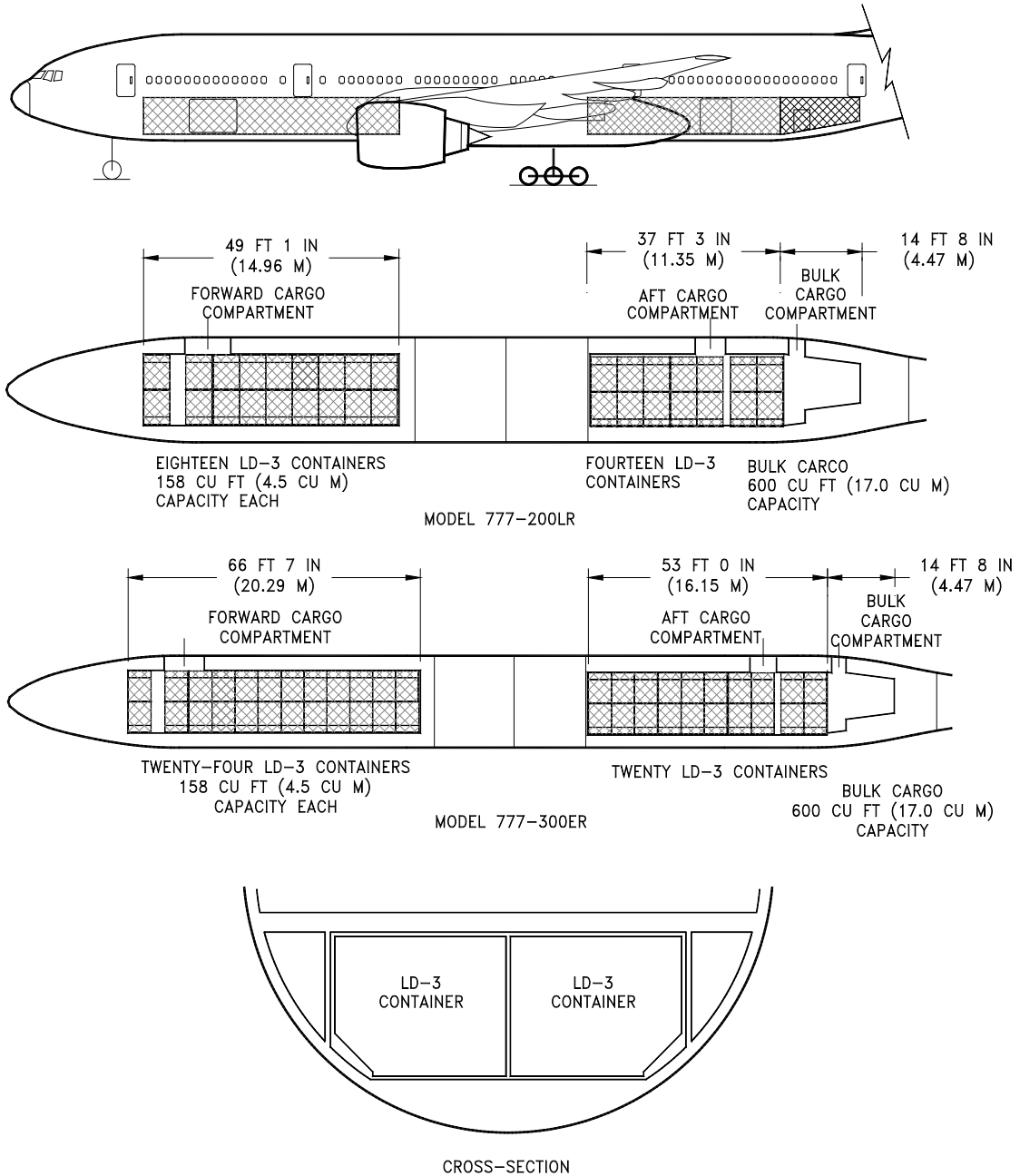

## 2.6.2 Lower Cargo Compartments: Model 777-200LR, 777F, Optional Aft Large Cargo Door

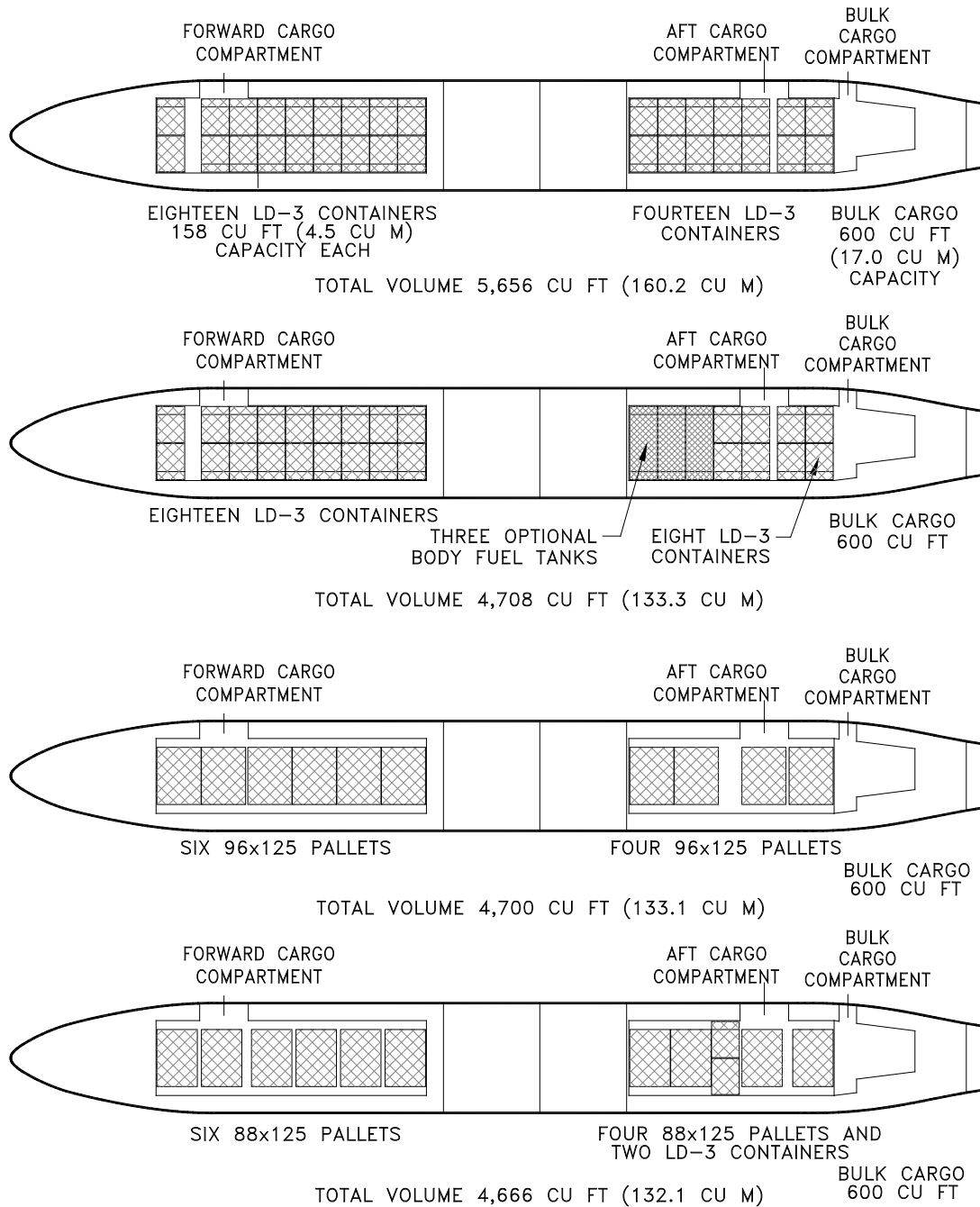

D6-58329-2

### 2.6.3 Lower Cargo Compartments: Model 777-300ER, Optional Aft Large Cargo Door

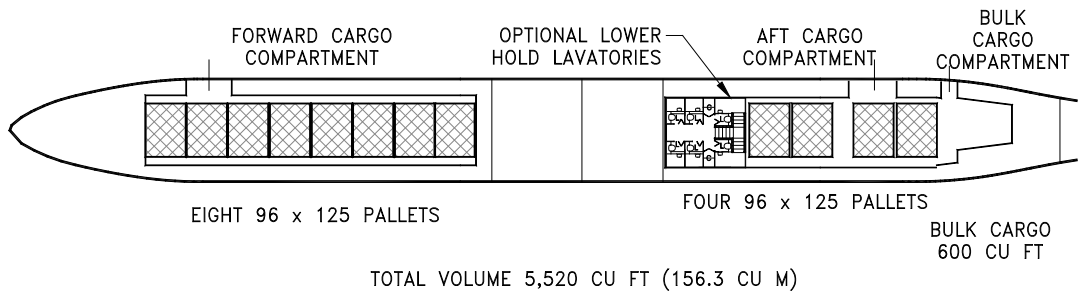
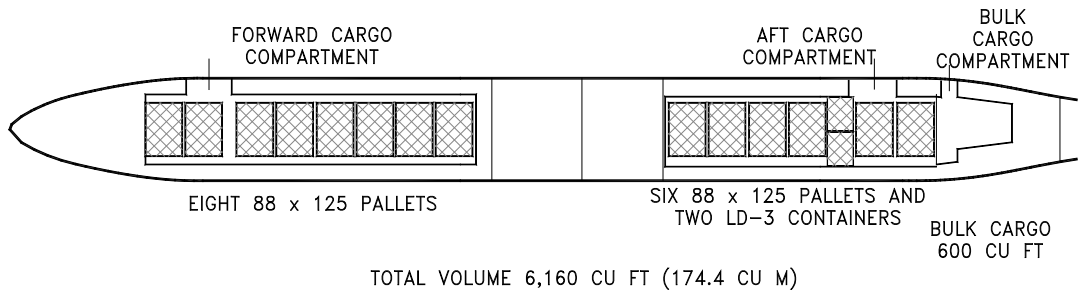
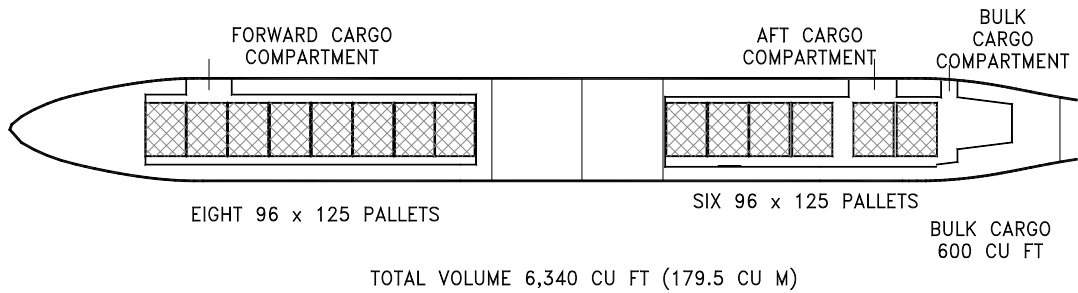
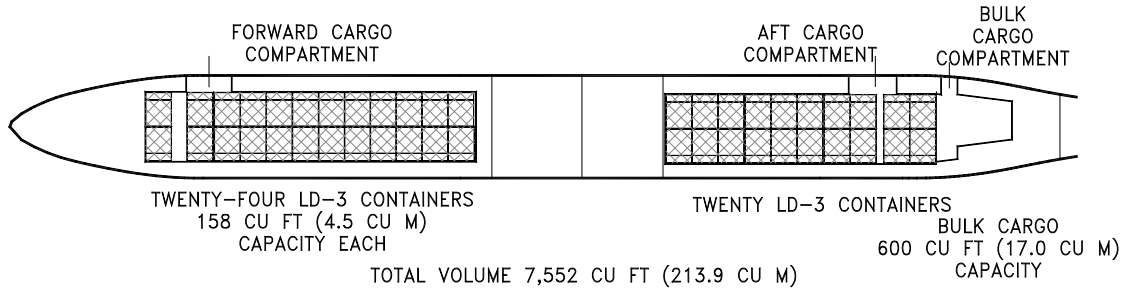

---

**2.6.4 Main Deck Cargo: Model 777F**

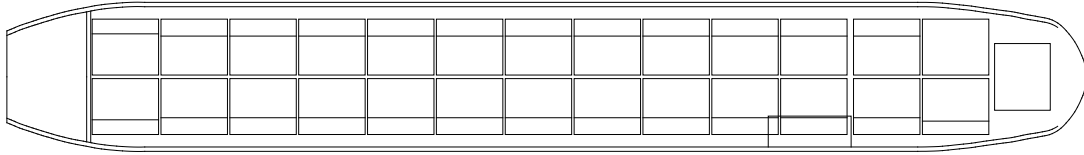

(27) 96" X 125" PALLETS

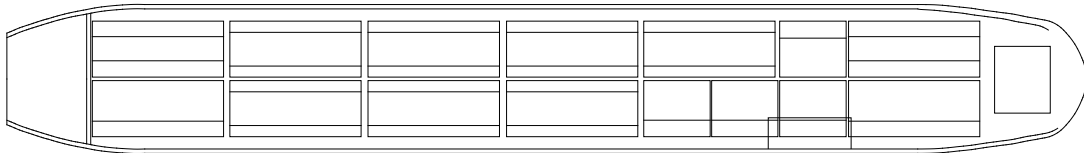

(11) 96" X 238.5" PALLETS

(5) 96" X 125" PALLETS

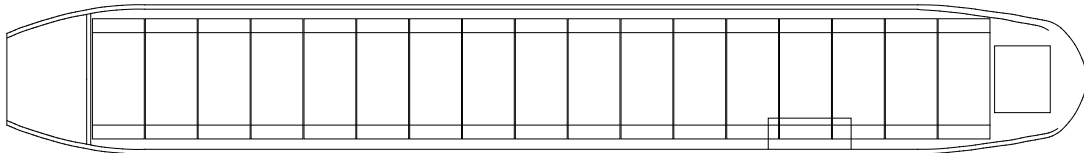

(17) 96" X 196" PALLETS

(1) 96" X 125" PALLET

ADDITIONAL PALLET LOCKS REQUIRED

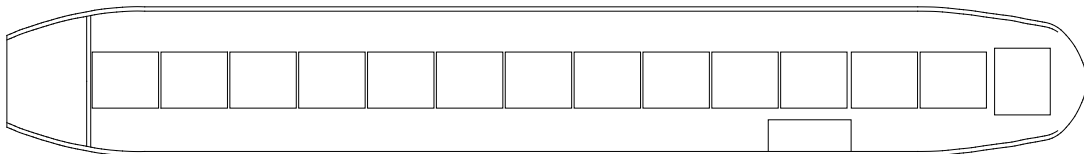

(14) 96" X 125" PALLETS

## 2.7 DOOR CLEARANCES

### 2.7.1 Door Clearances: Model 777-200LR, -300ER, 777F, Main Entry Door Locations

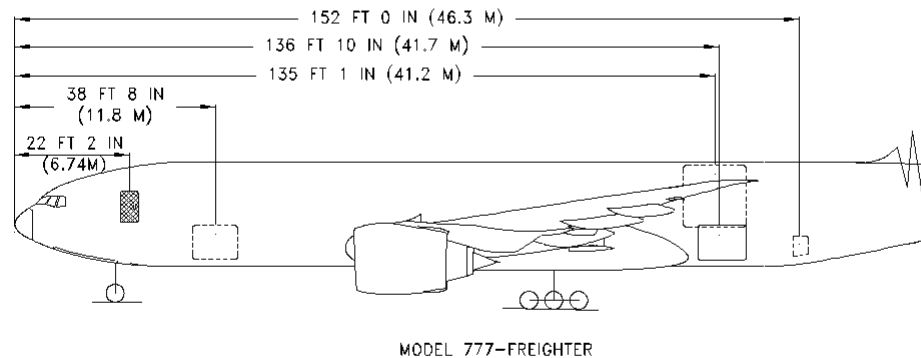
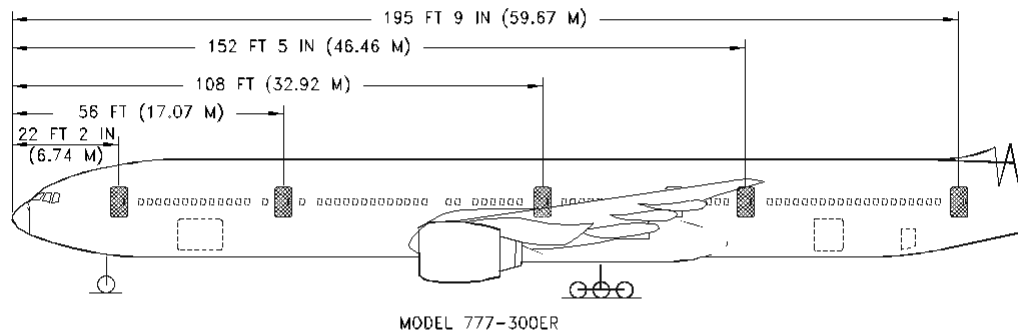
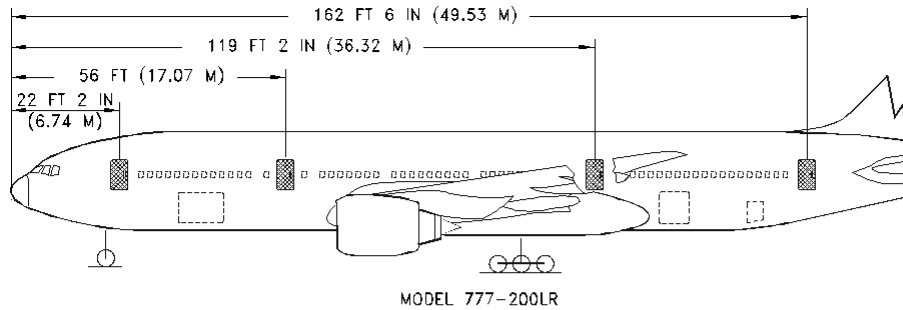

NOTES:

1. MODEL 777-200LR - EIGHT PASSENGER DOORS, 4 ON EACH SIDE  
DOOR OPENING SIZE = 42 BY 74 IN (1.07 BY 1.88 M)  
DOOR SIZE = 42 BY 74 IN (1.07 BY 1.88 M)
2. MODEL 777-300ER - TEN PASSENGER DOORS, 5 ON EACH SIDE  
DOOR OPENING AND SIZE SAME AS IN 777-200LR
3. MODEL 777-FREIGHTER - TWO PASSENGER DOORS, 1 ON EACH SIDE  
DOOR OPENING AND SIZE SAME AS IN 777-200LR
4. DOORS ARE TRANSLATING TYPE A DOORS.
5. SEE SECTION 2.3 FOR DOOR SILL HEIGHTS

**2.7.2 Door Clearances: Model 777-200LR, -300ER, 777F, Main Entry Door No 1.**

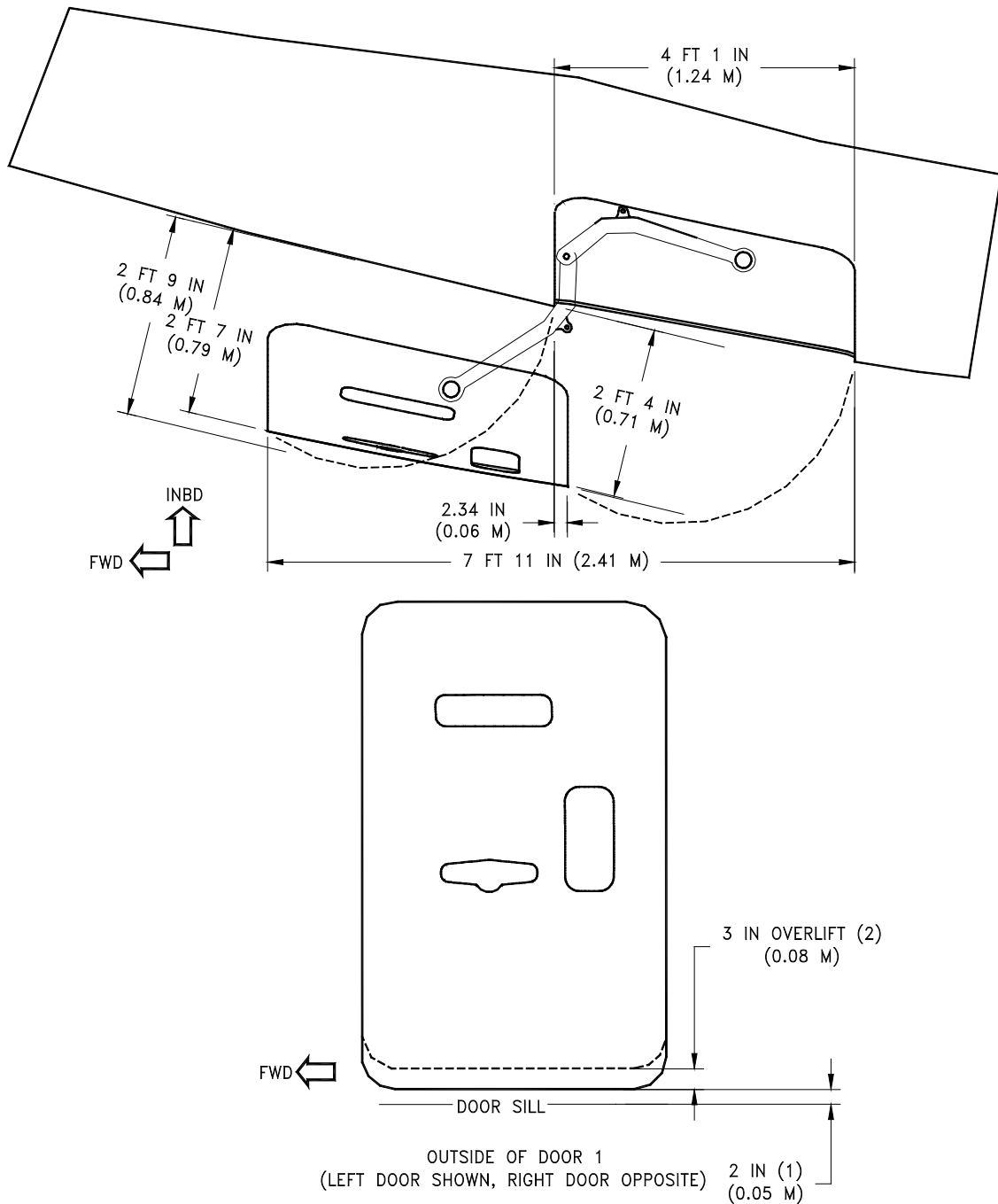

**NOTES:**

- (1) DOOR MOVES UPWARD 2 IN. AND INWARD 0.4 IN. TO CLEAR STOPS BEFORE OPENING OUTWARD
- (2) DOOR CAPABLE OF MOVING AN ADDITIONAL 3 IN VERTICALLY (OVERLIFT) TO PRECLUDE DAMAGE FROM CONTACT WITH LOADING BRIDGE

**2.7.3 Door Clearances: Model 777-200LR, -300ER, Main Entry Door No 2, and No 3.**

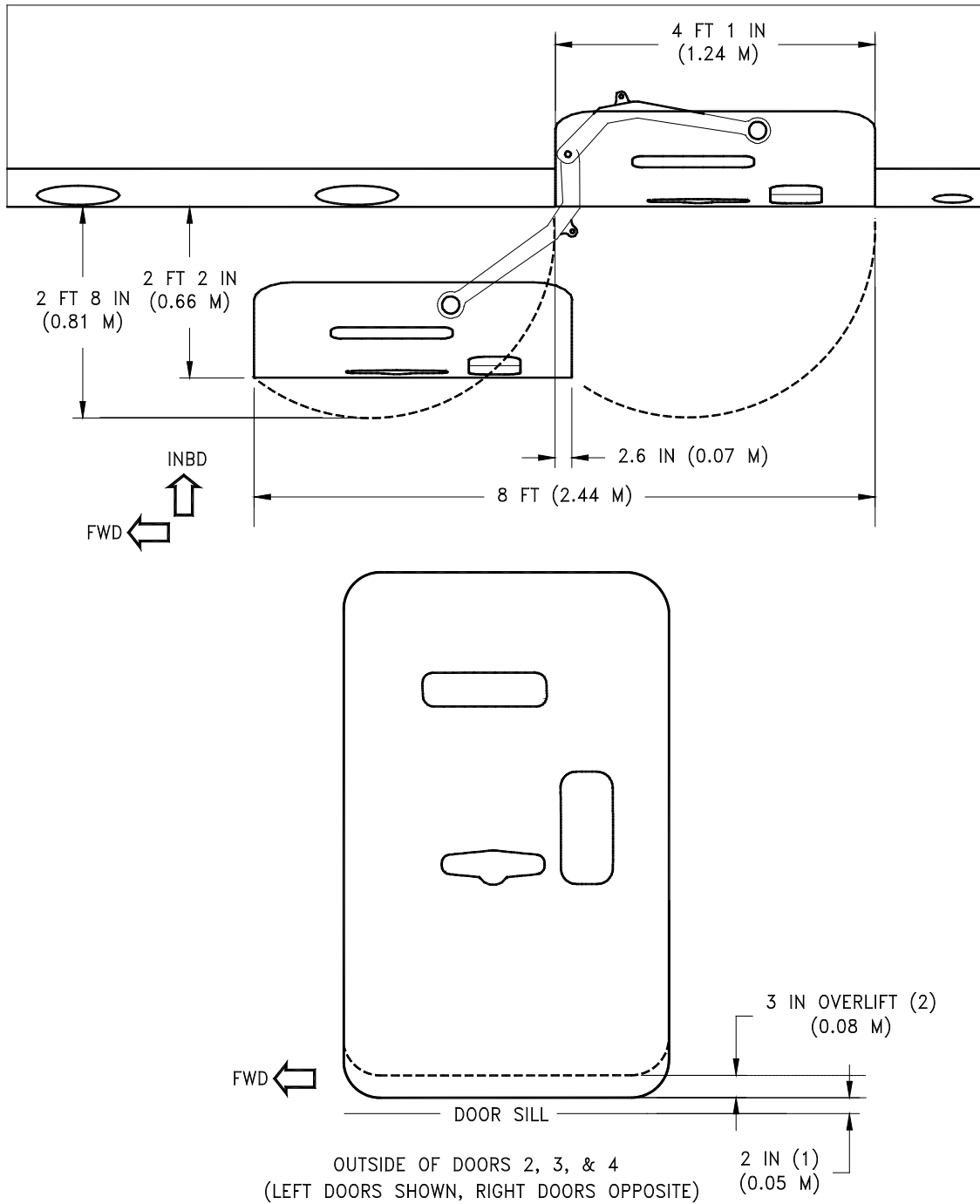

**NOTES:**

- (1) DOOR MOVES UPWARD 2 IN. AND INWARD 0.4 IN TO CLEAR STOPS BEFORE OPENING OUTWARD
- (2) DOOR CAPABLE OF MOVING AN ADDITIONAL 3 IN VERTICALLY (OVERLIFT) TO PRECLUDE DAMAGE FROM CONTACT WITH LOADING BRIDGE

**2.7.4 Door Clearances: Model 777-200LR, -300ER, Main Entry Door No 4, or No 5**

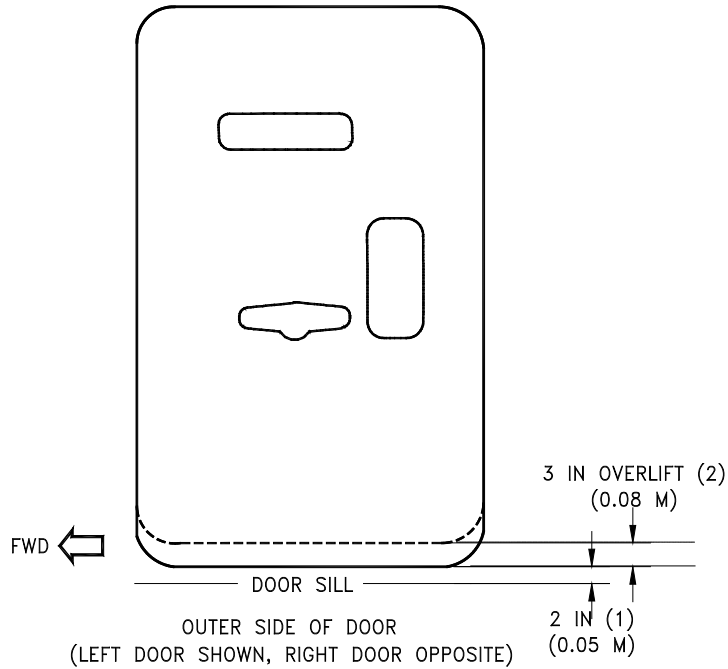
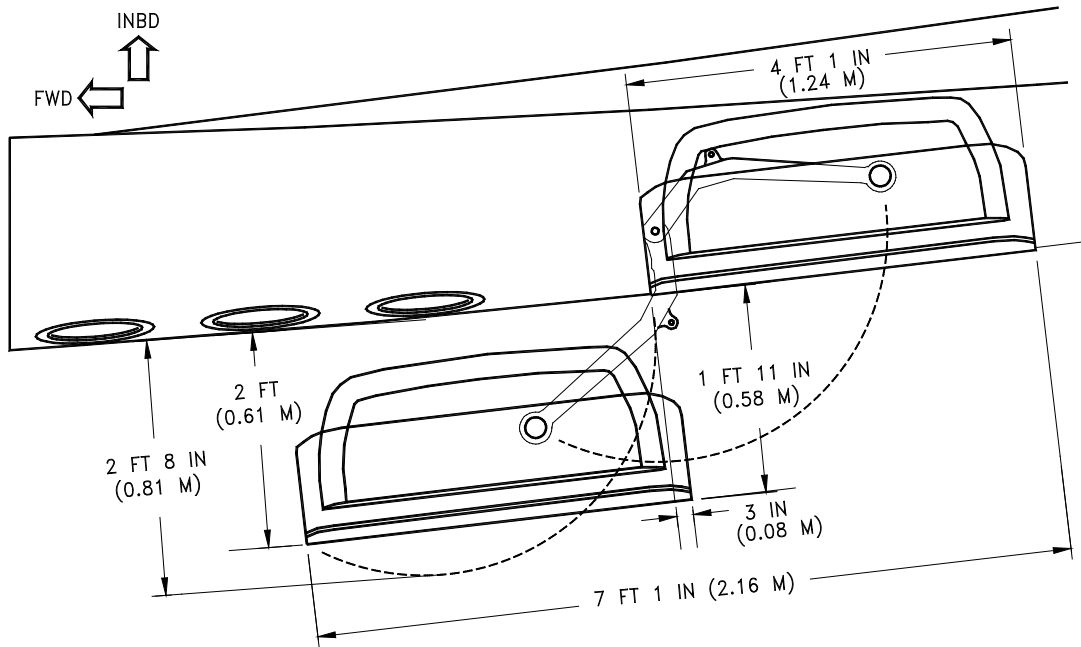

**NOTES:**

- (1) DOOR MOVES UPWARD 2 IN. AND INWARD 0.4 IN. TO CLEAR STOPS BEFORE OPENING OUTWARD
- (2) DOOR CAPABLE OF MOVING AN ADDITIONAL 3 IN VERTICALLY (OVERLIFT) TO PRECLUDE DAMAGE FROM CONTACT WITH LOADING BRIDGE
- (3) DOOR NO 4 ON 777-200LR, DOOR NO 5 ON 777-300ER



## 2.7.5 Door Clearances: Model 777-200LR, -300ER, Cargo Door Locations

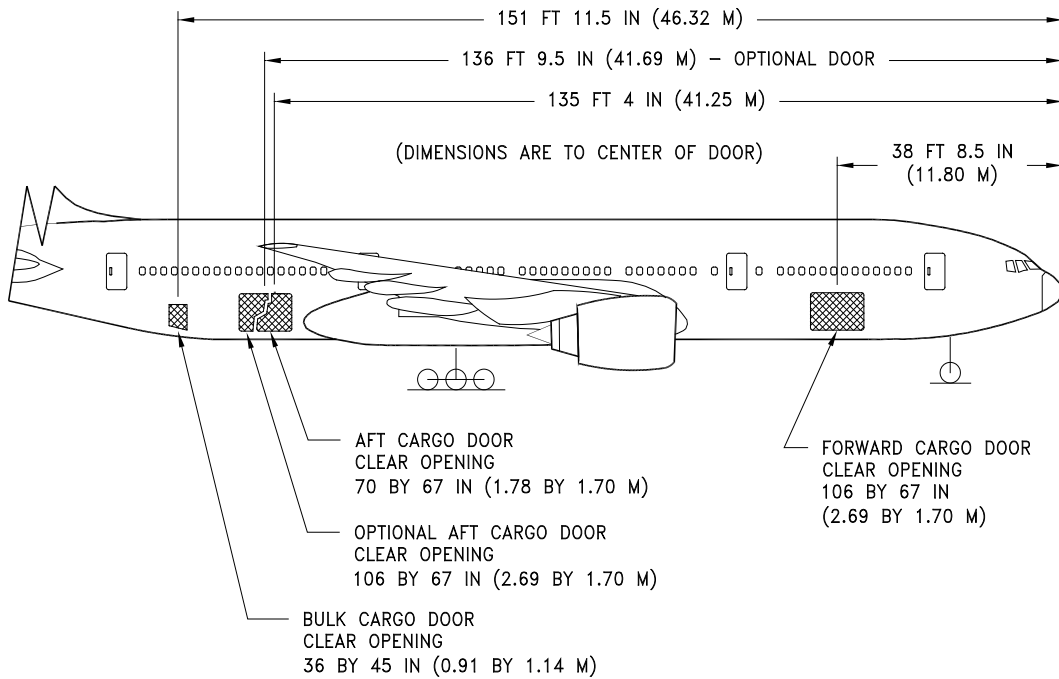

MODEL 777-200LR

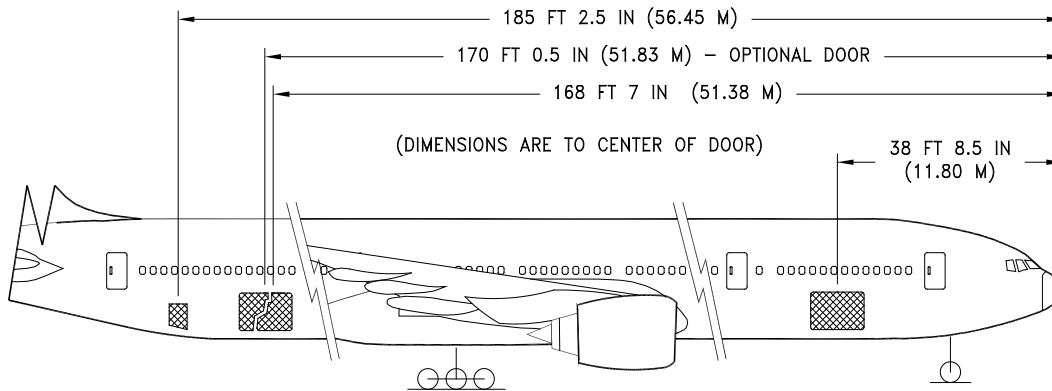

MODEL 777-300ER

(NOTE: DOOR DIMENSIONS SAME AS FOR 777-200LR)

---

## 2.7.6 Door Clearances: Model 777F, Cargo Door Locations

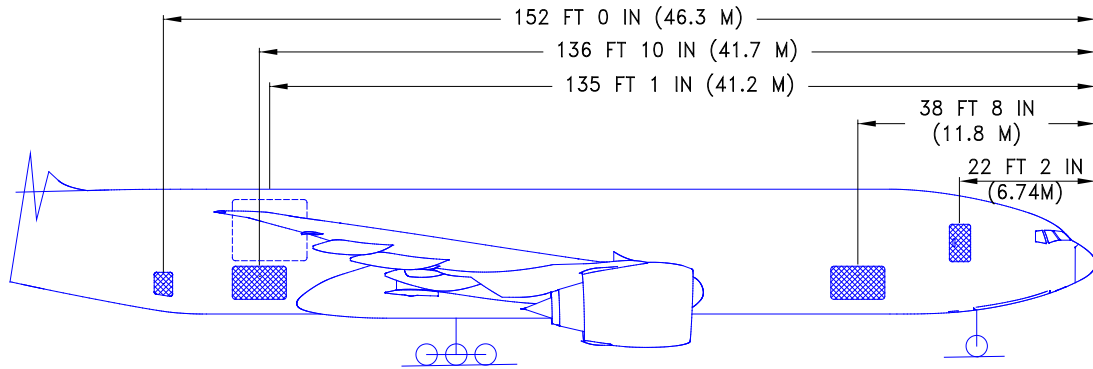

MODEL 777-FREIGHTER

NOTES:

1. MODEL 777-FREIGHTER – TWO PASSENGER DOORS, 1 ON EACH SIDE  
DOOR OPENING AND SIZE SAME AS IN 777-200LR
3. SEE SECTION 2.3 FOR DOOR SILL HEIGHTS

## 2.7.7 Door Clearances: Model 777-200LR, -300ER, 777F, Forward Cargo Door

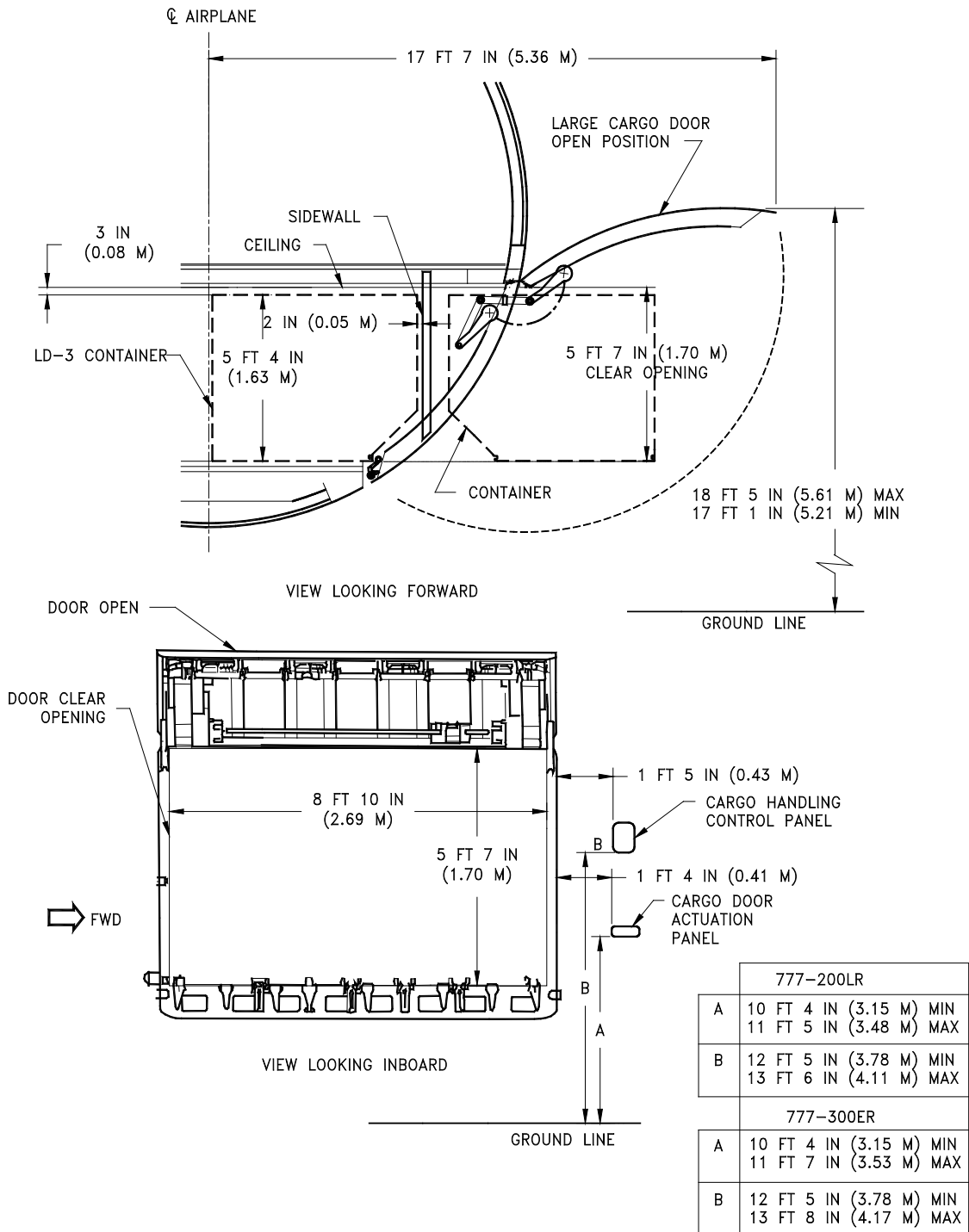

D6-58329-2

REV F

December 2022

2-25

## 2.7.8 Door Clearances: Model 777-200LR, -300ER, Small Aft Cargo Door

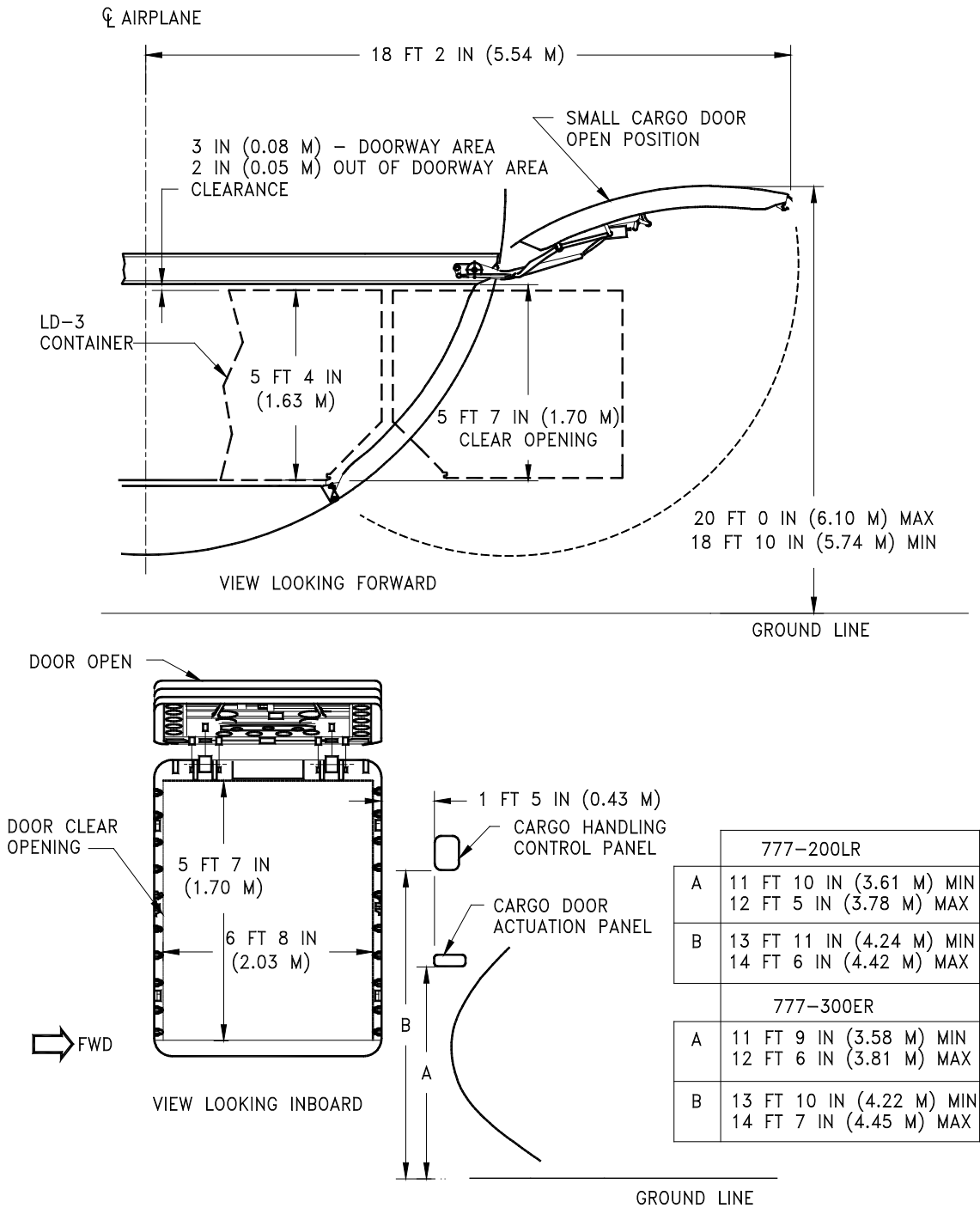

D6-58329-2

REV F

December 2022

2-26

**2.7.9 Door Clearances: Model 777-200LR, -300ER, 777F, Bulk Cargo Door**

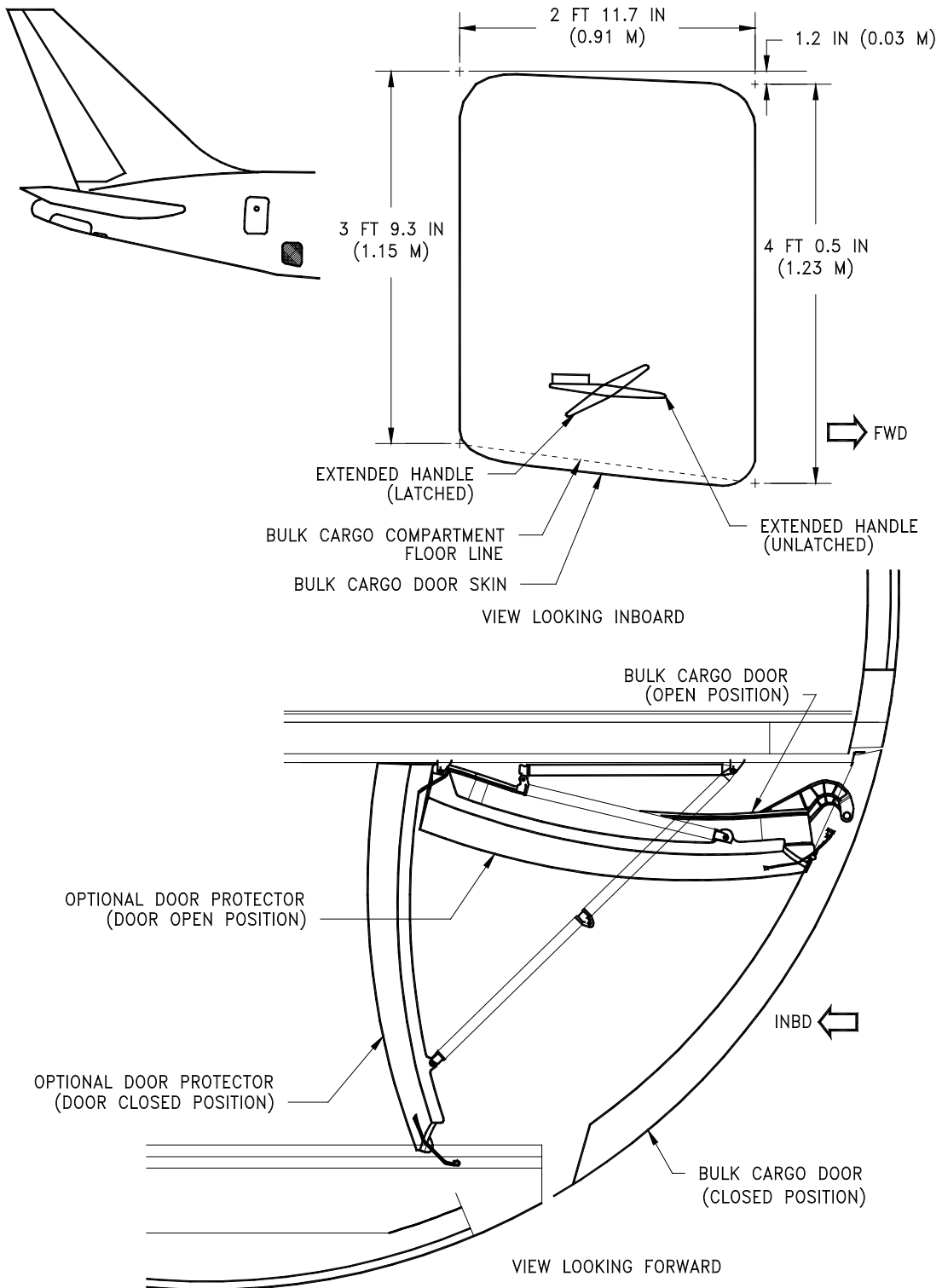

D6-58329-2

---

### 3.0 AIRPLANE PERFORMANCE

#### 3.1 GENERAL INFORMATION

The graphs in Section 3.2 provide information on operational empty weight (OEW) and payload, trip range, brake release gross weight, and fuel limits for airplane models with the different engine options. To use these graphs, if the trip range and zero fuel weight (OEW + payload) are known, the approximate brake release weight can be found.

The graphs in Section 3.3 provide information on F.A.R. takeoff runway length requirements with the different engines at different pressure altitudes. Maximum takeoff weights shown on the graphs are the heaviest for the particular airplane models with the corresponding engines. Standard day temperatures for pressure altitudes shown on the F.A.R. takeoff graphs are given below:

PRESSURE ALTITUDE		STANDARD DAY TEMP	
FEET	METERS	°F	°C
0	0	59.0	15.00
2,000	610	51.9	11.04
4,000	1,219	44.7	7.06
6,000	1,829	37.6	3.11
8,000	2,438	30.5	-0.85
8,800	2,682	31.2	-1.00
10,000	3,048	23.3	-4.81

The graphs in Section 3.4 provide information on landing runway length requirements for different airplane weights and airport altitudes. The maximum landing weights shown are the heaviest for the particular airplane model.

### 3.2 PAYLOAD/RANGE FOR LONG RANGE CRUISE FOR 0.84 MACH CRUISE

#### 3.2.1 Payload/Range for 0.84 Mach Cruise: Model 777-200LR (GE90-100 Series Engines)

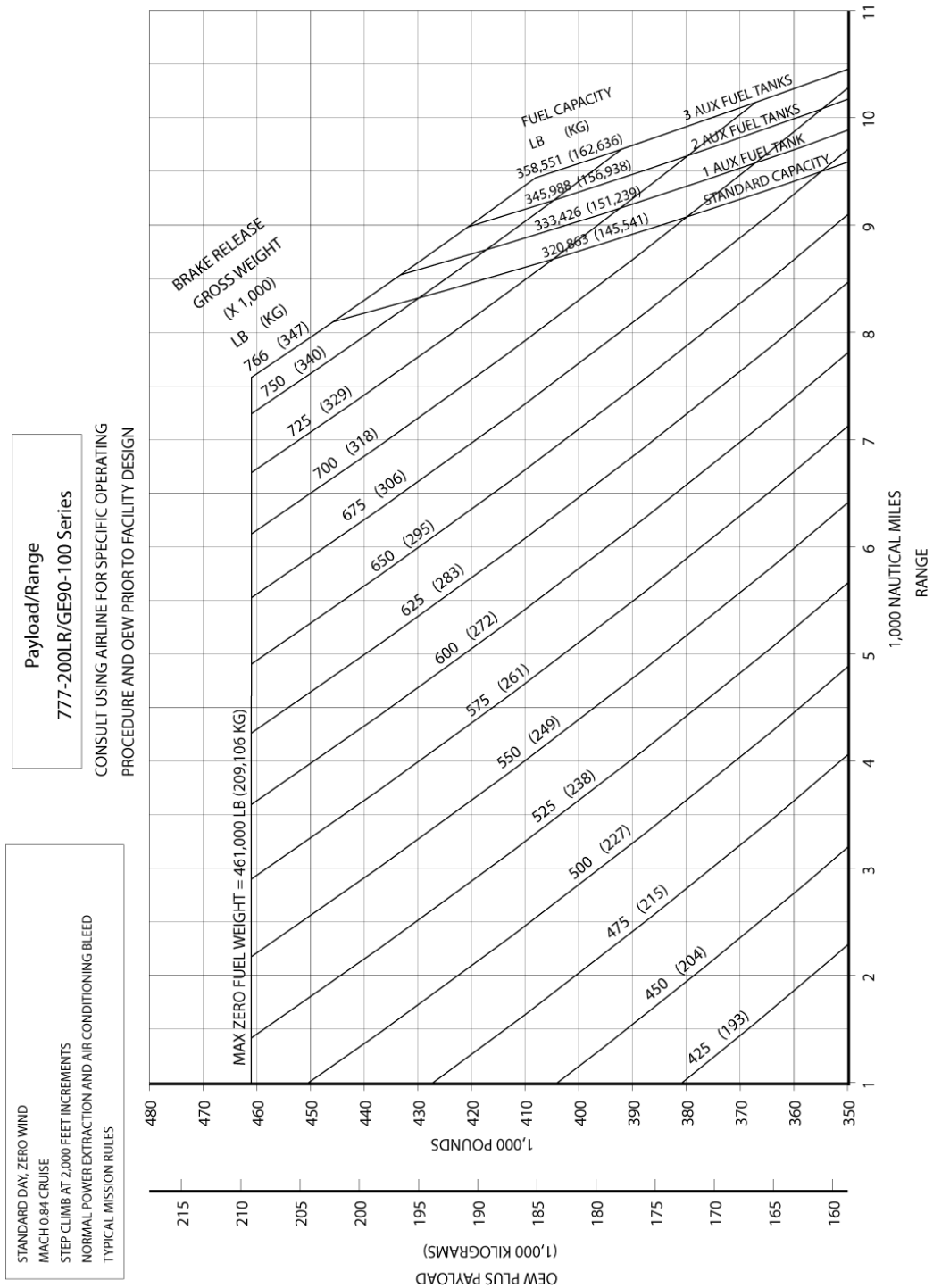

### 3.2.2 Payload/Range for 0.84 Mach Cruise: Model 777-300ER (GE90-115BL Engines)

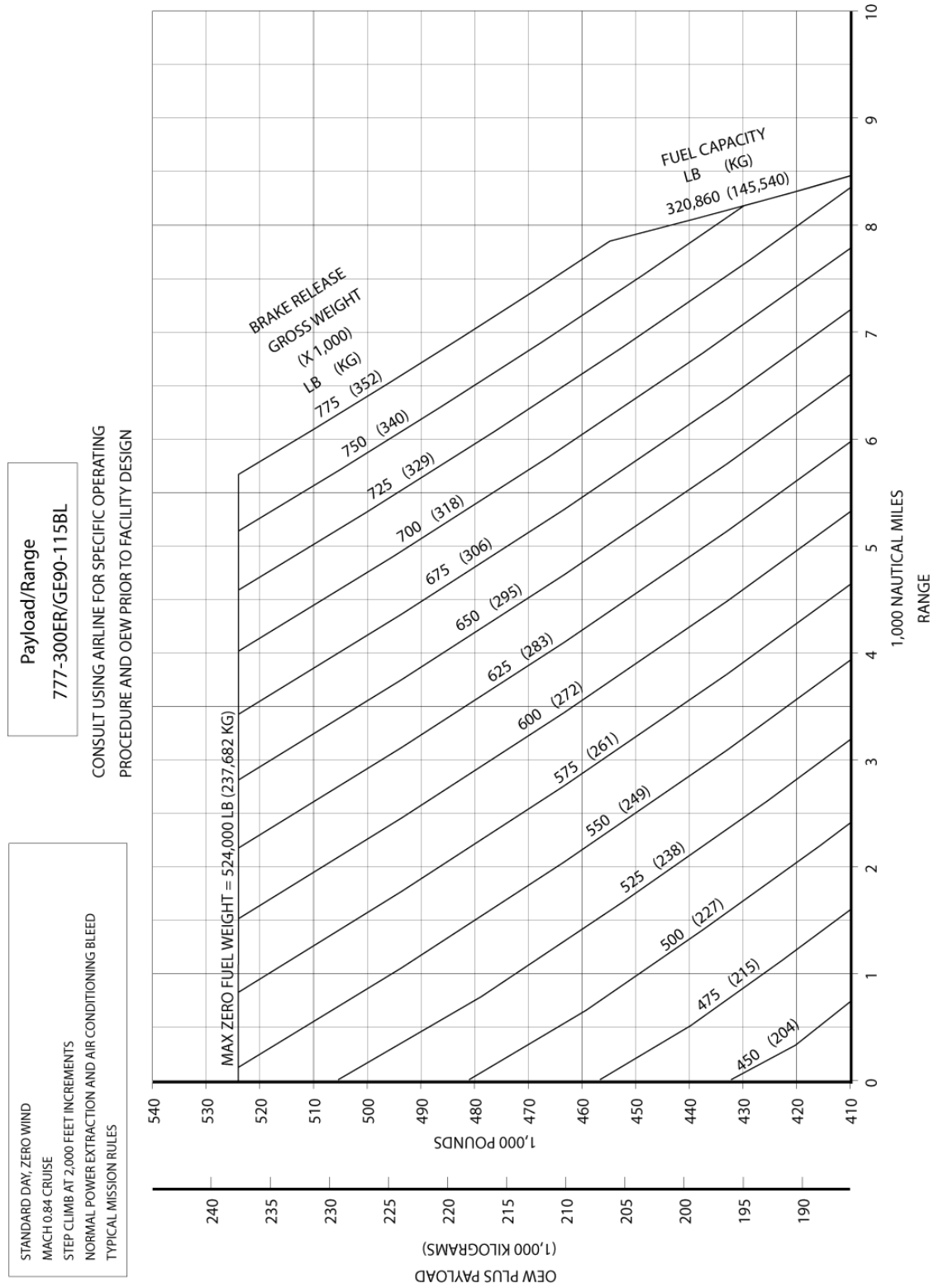



### 3.2.3 Payload/Range for 0.84 Mach Cruise: Model 777F (GE90-100 Series Engines)

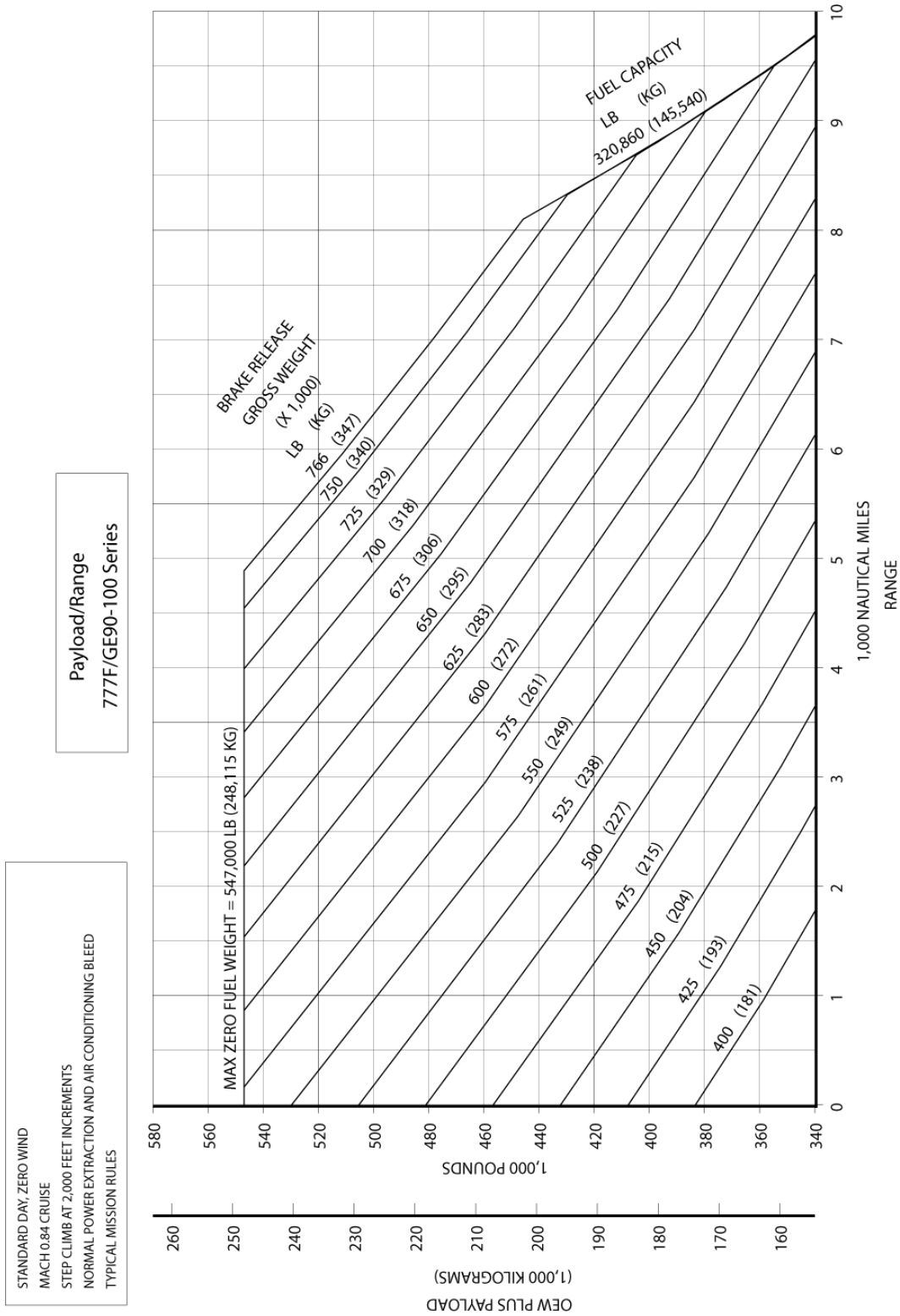

### 3.3 F.A.R. TAKEOFF RUNWAY LENGTH REQUIREMENTS

#### 3.3.1 F.A.R. Takeoff Runway Length Requirements - Standard Day: Model 777-200LR (GE90-100B1L Engines)

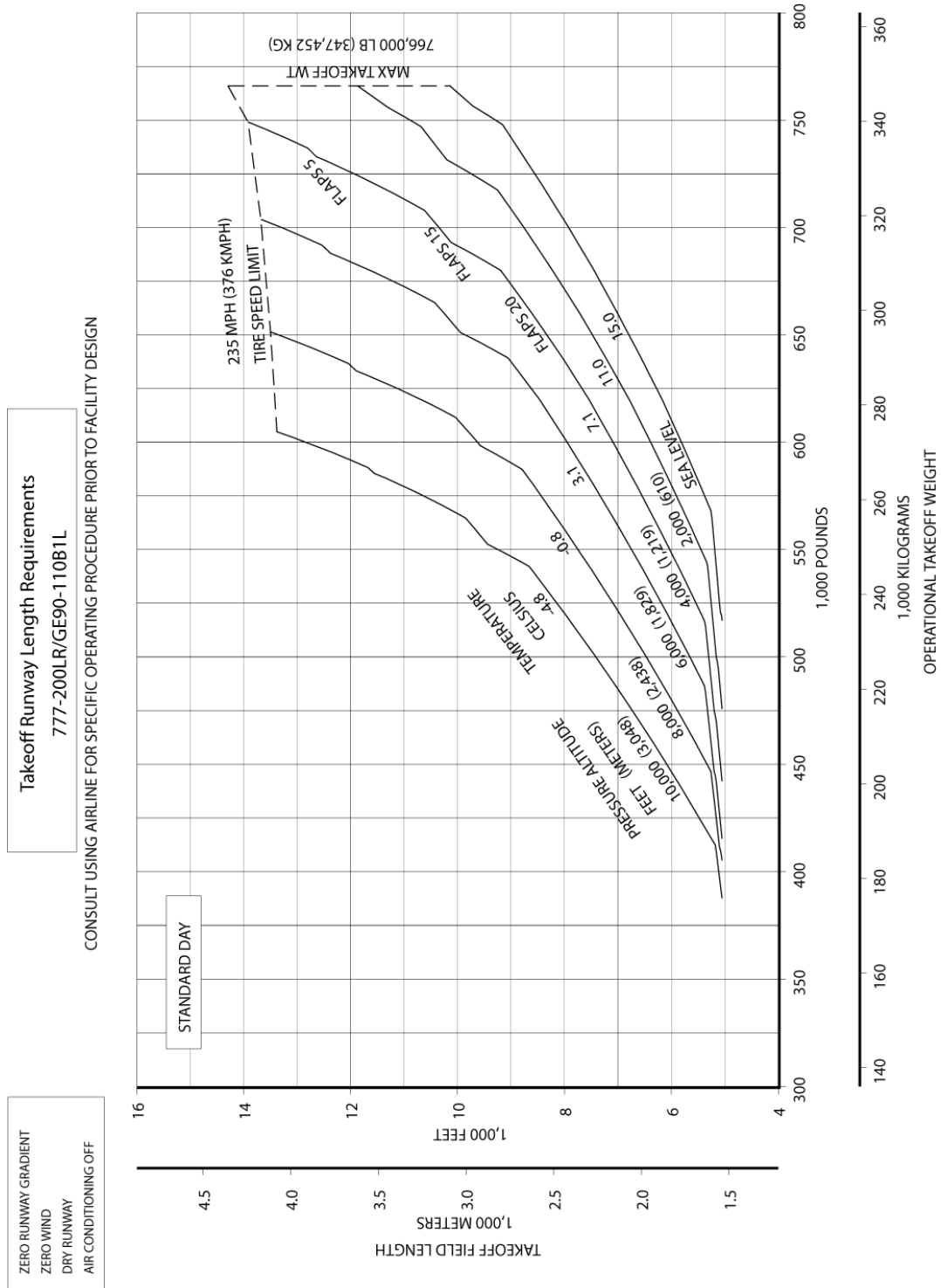

### 3.3.2 F.A.R. Takeoff Runway Length Requirements - Standard Day + 27°F (STD + 15°C): Model 777-200LR (GE90-110B1L Engines)

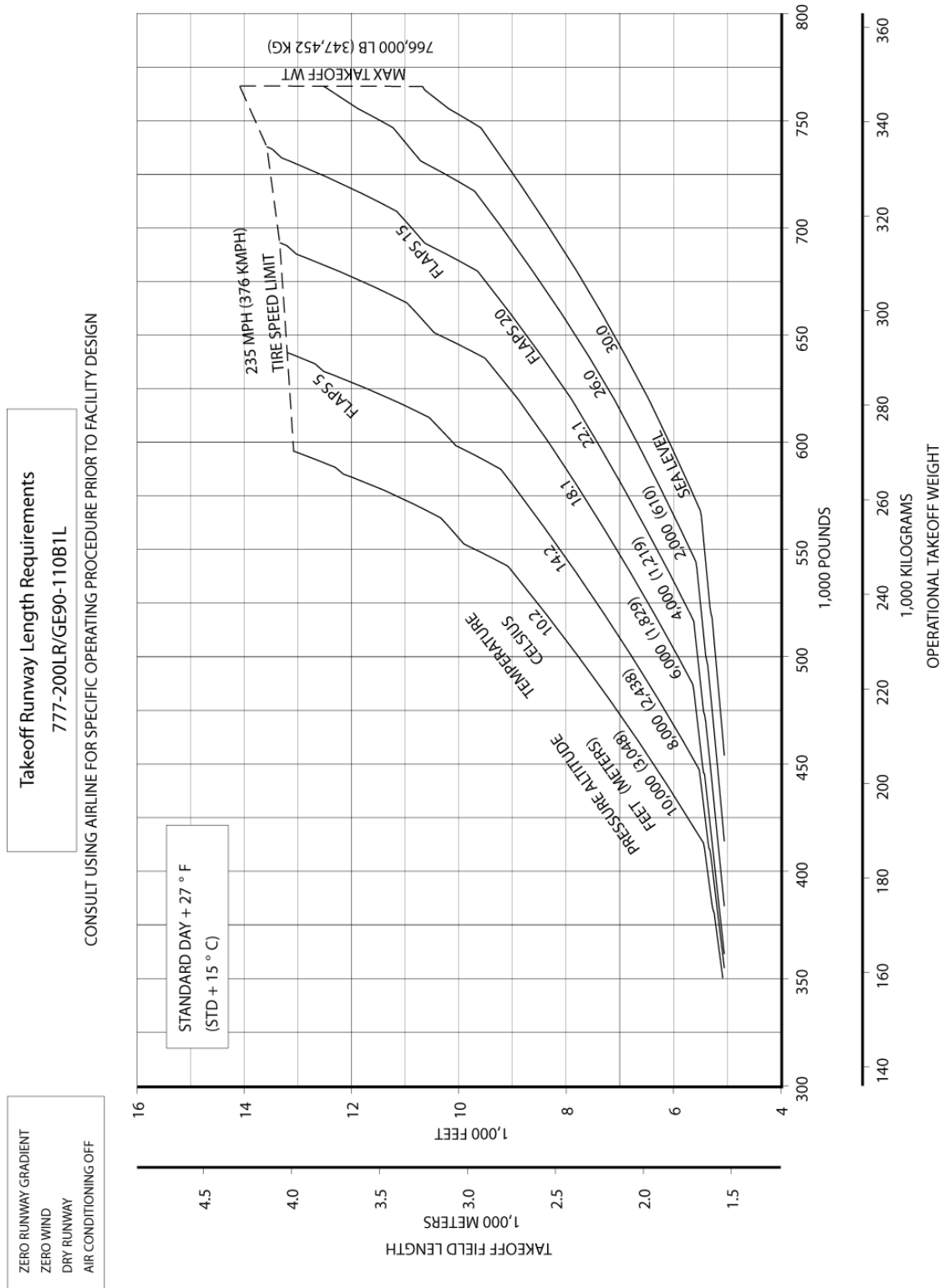

### 3.3.3 F.A.R. Takeoff Runway Length Requirements - Standard Day + 49°F (STD + 27°C): Model 777-200LR (GE90-110B1L Engines)

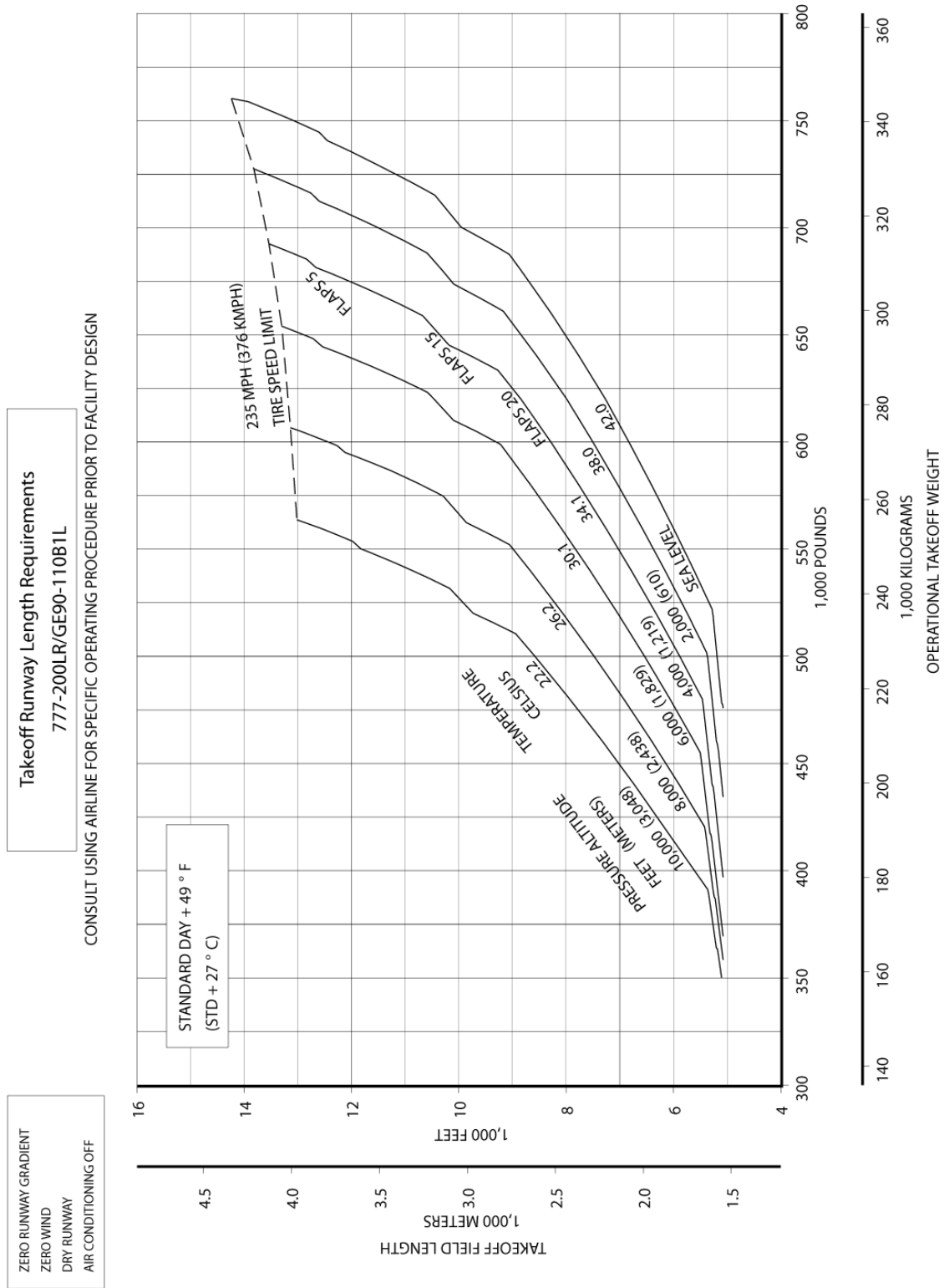

### 3.3.4 F.A.R. Takeoff Runway Length Requirements - Standard Day + 59°F (STD + 33°C): Model 777-200LR (GE90-110B1L Engines)

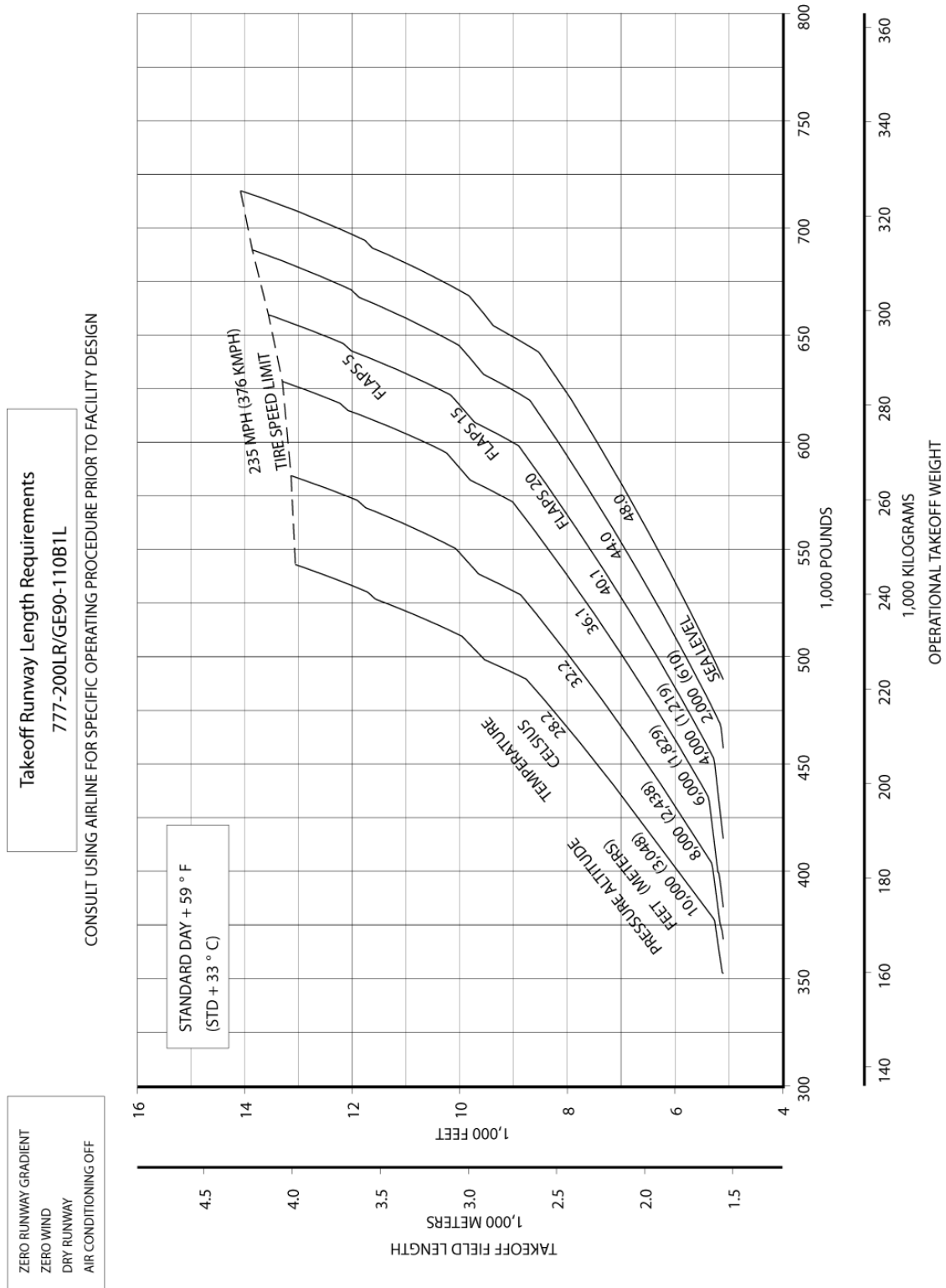

ZERO RUNWAY GRADIENT  
 ZERO WIND  
 DRY RUNWAY  
 AIR CONDITIONING OFF

### 3.3.5 F.A.R. Takeoff Runway Length Requirements - Standard Day: Model 777-200LR (GE90-115BL Engines)

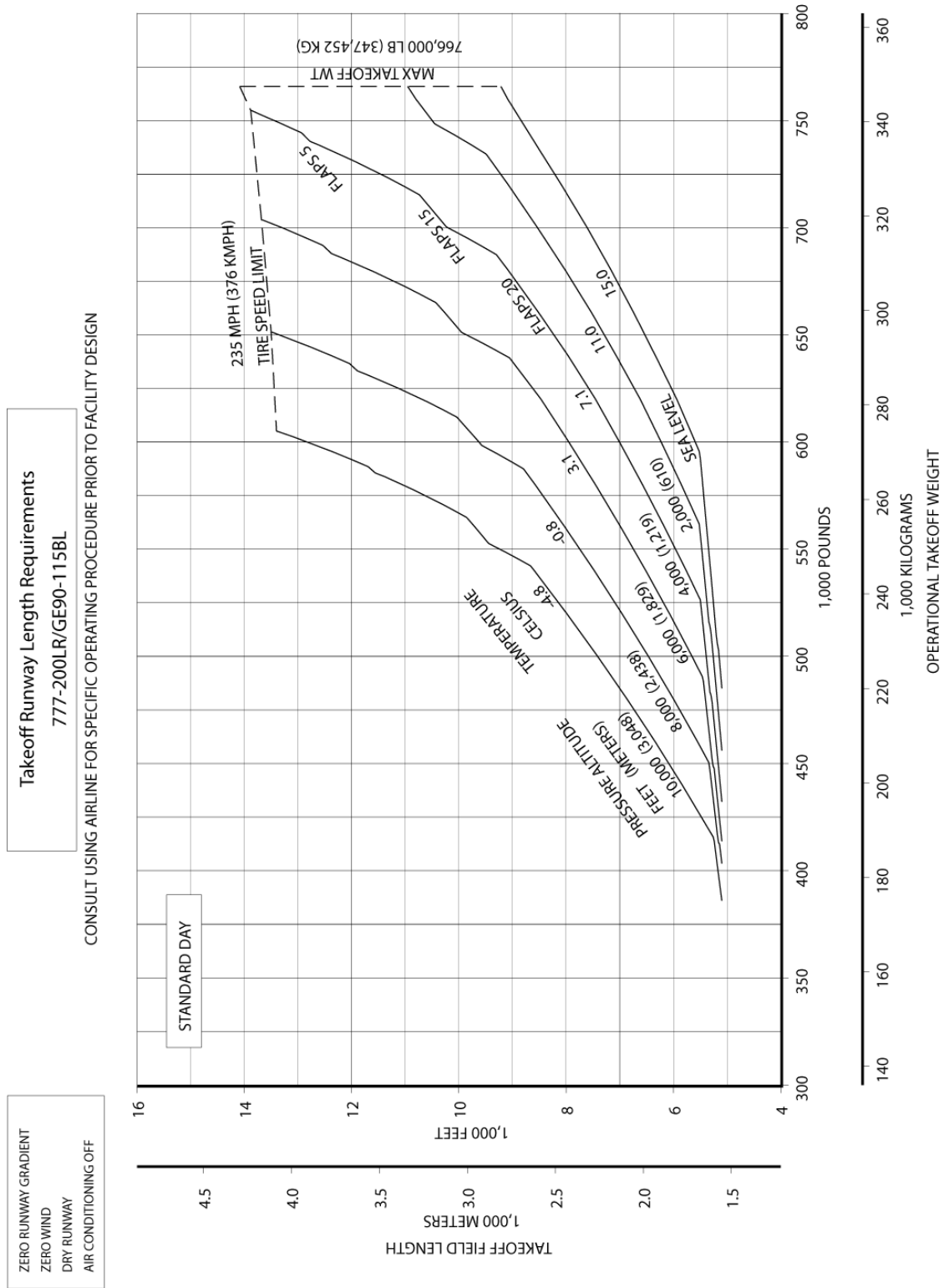

### 3.3.6 F.A.R. Takeoff Runway Length Requirements - Standard Day + 27°F (STD + 15°C): Model 777-200LR (GE90-115BL Engines)

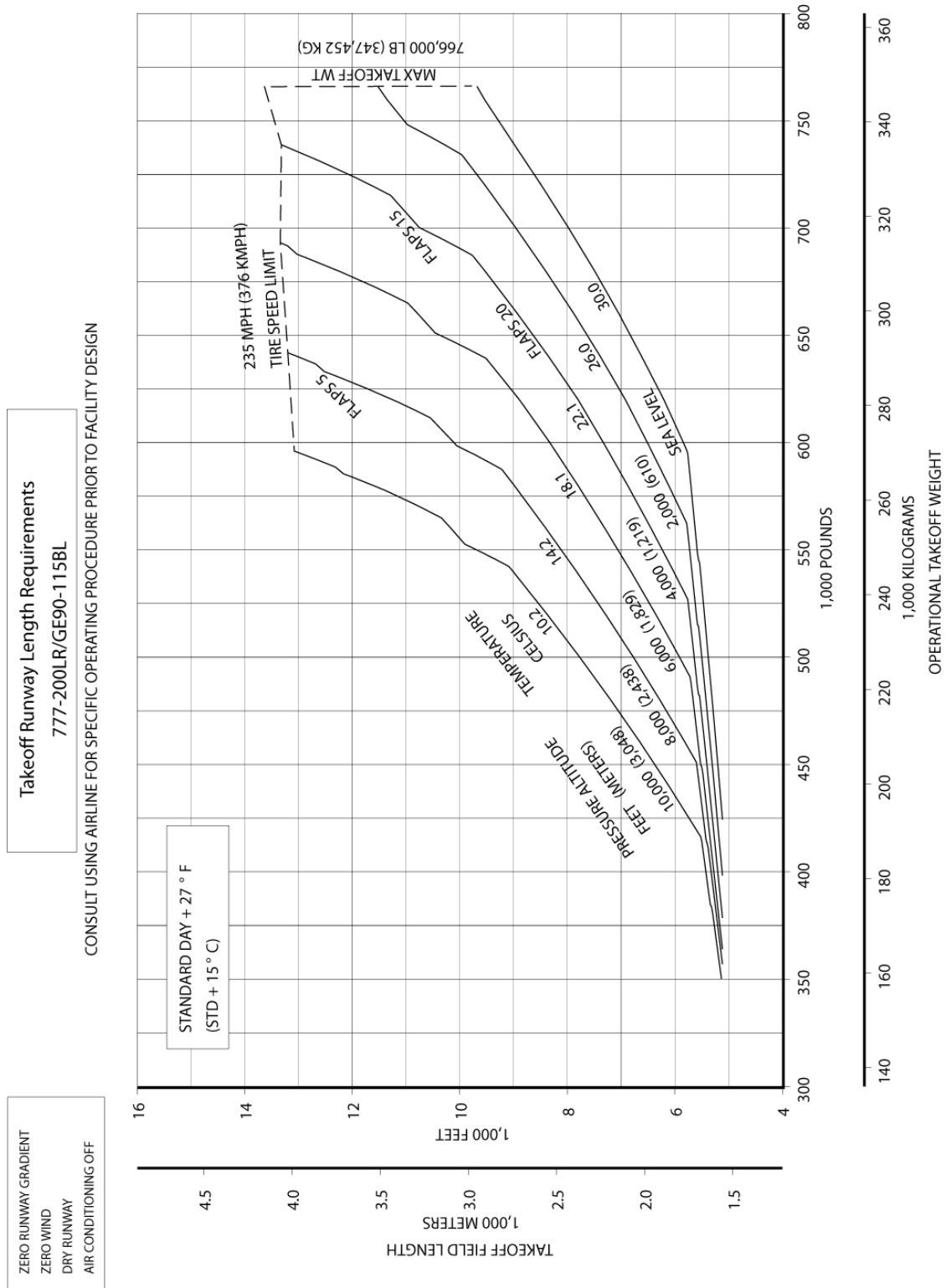

### 3.3.7 F.A.R. Takeoff Runway Length Requirements - Standard Day + 49°F (STD + 27°C): Model 777-200LR (GE90-115BL Engines)

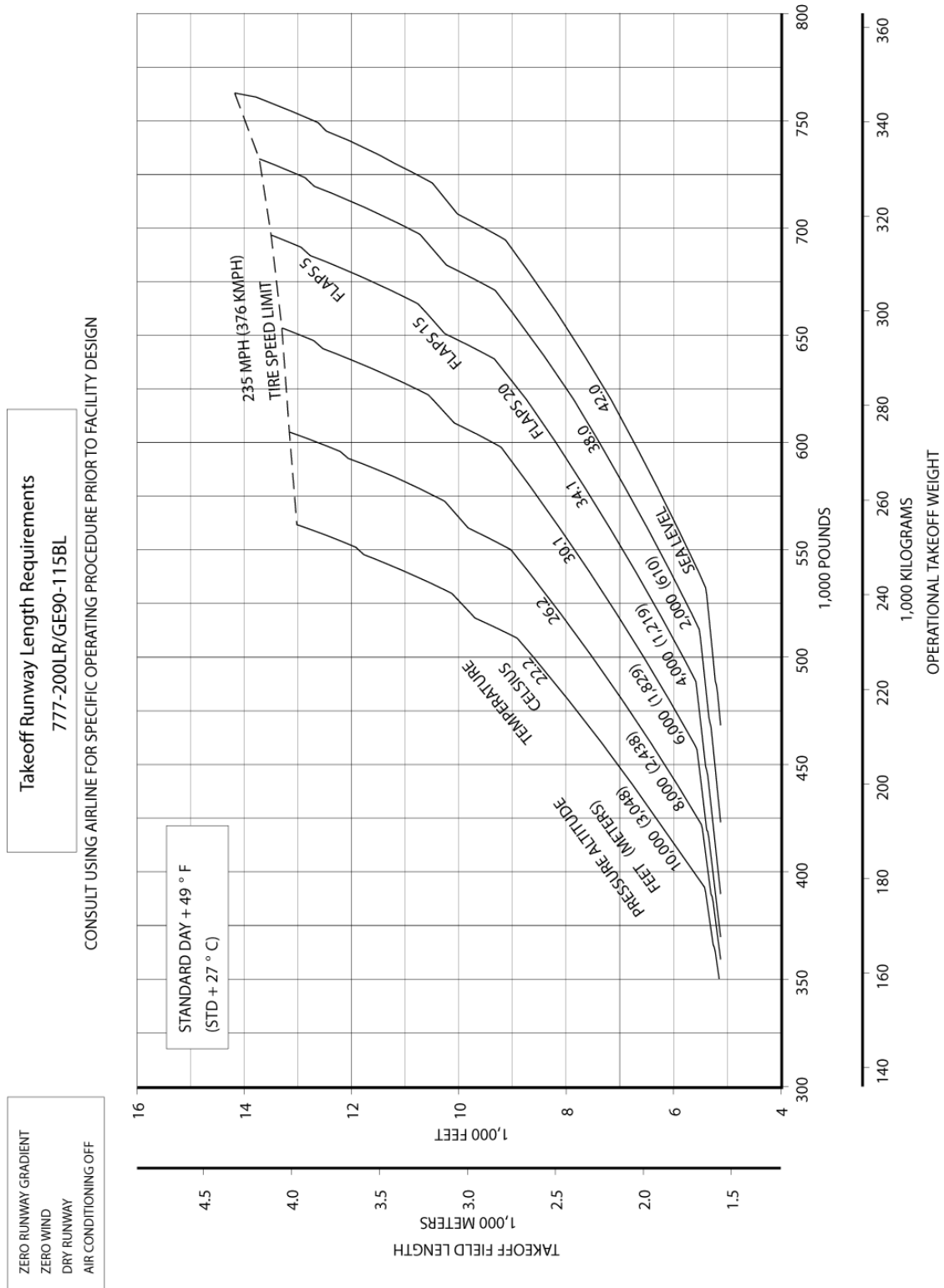

D6-58329-2

December 2022

REV F

3-11



### 3.3.8 F.A.R. Takeoff Runway Length Requirements - Standard Day + 59°F (STD + 33°C): Model 777-200LR (GE90-115BL Engines)

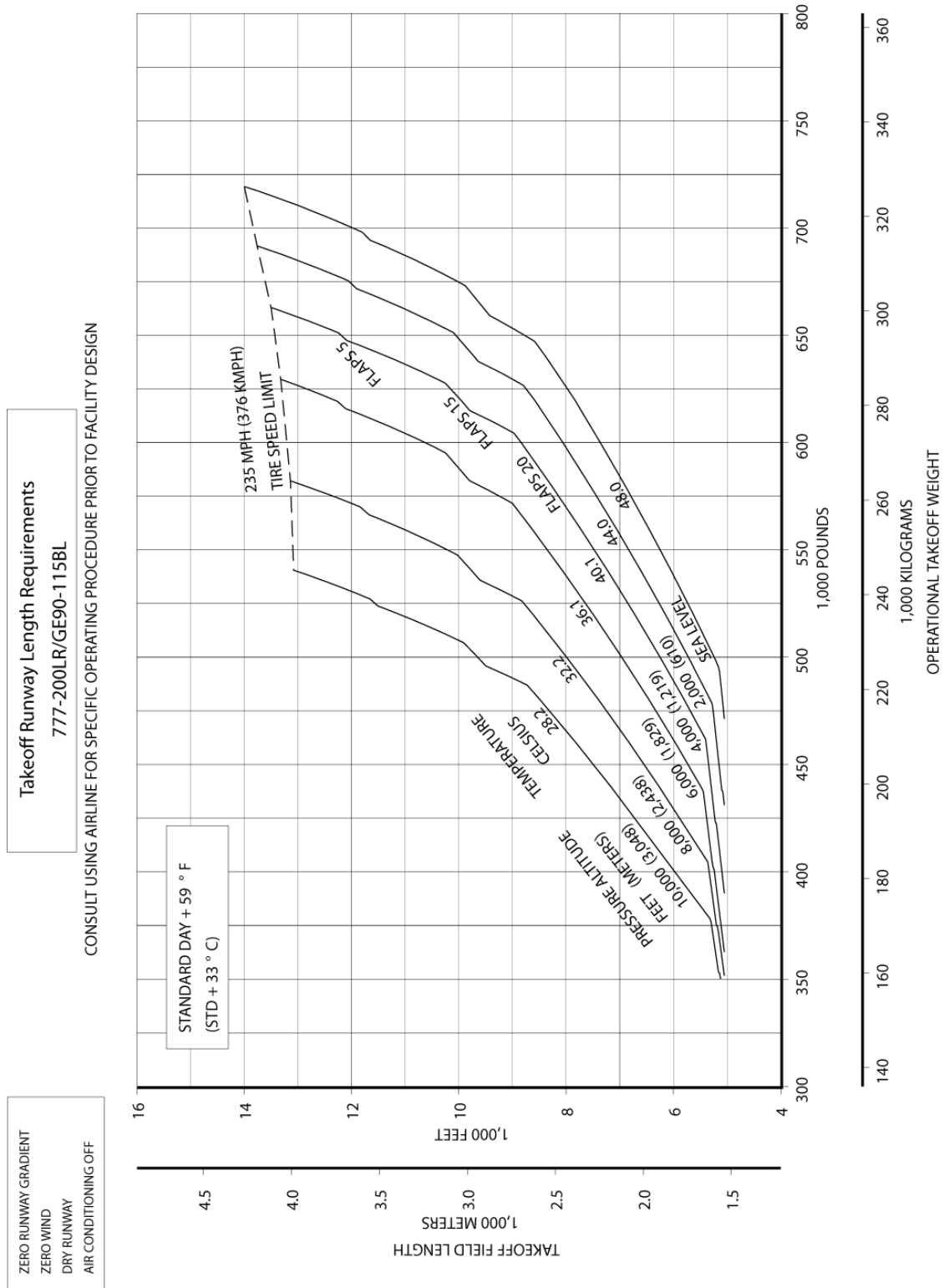

### 3.3.9 F.A.R. Takeoff Runway Length Requirements - Standard Day: Model 777-300ER (GE90-115BL Engines)

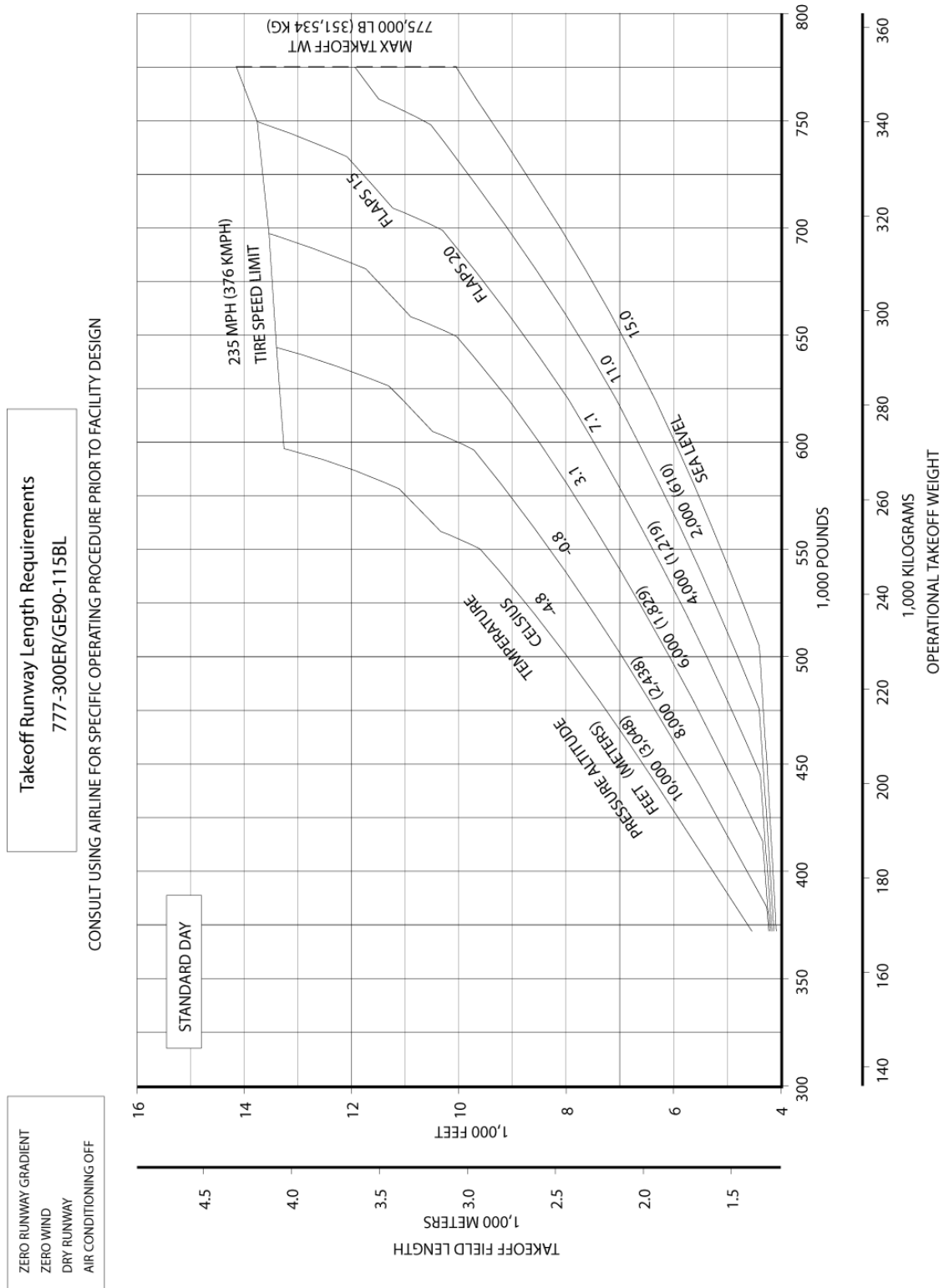

### 3.3.10 F.A.R. Takeoff Runway Length Requirements - Standard Day + 27°F (STD + 15°C): Model 777-300ER (GE90-115BL Engines)

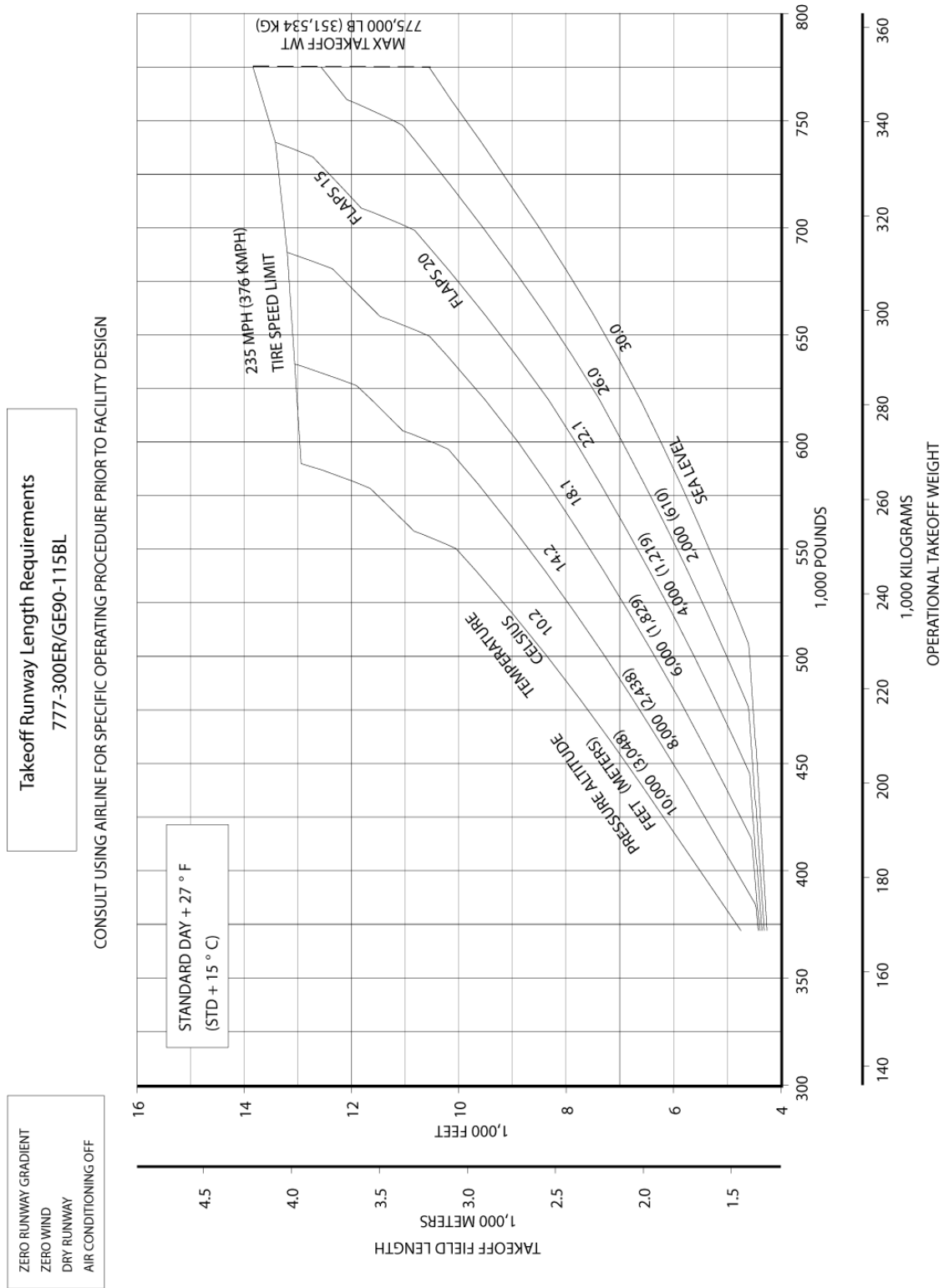

### 3.3.11 F.A.R. Takeoff Runway Length Requirements - Standard Day + 49°F (STD + 27°C): Model 777-300ER (GE90-115BL Engines)

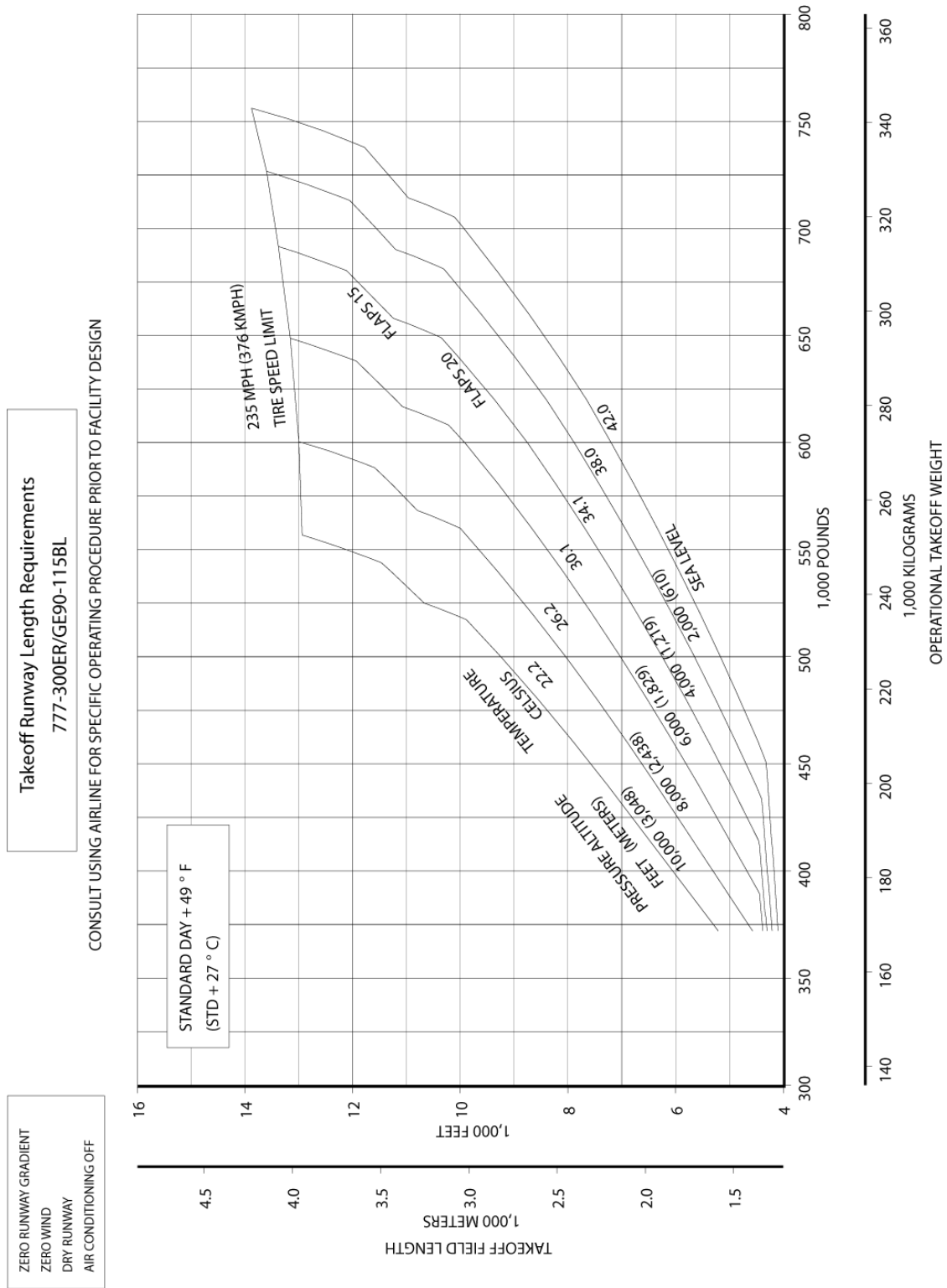

### 3.3.12 F.A.R. Takeoff Runway Length Requirements - Standard Day + 59°F (STD + 33°C): Model 777-300ER (GE90-115BL Engines)

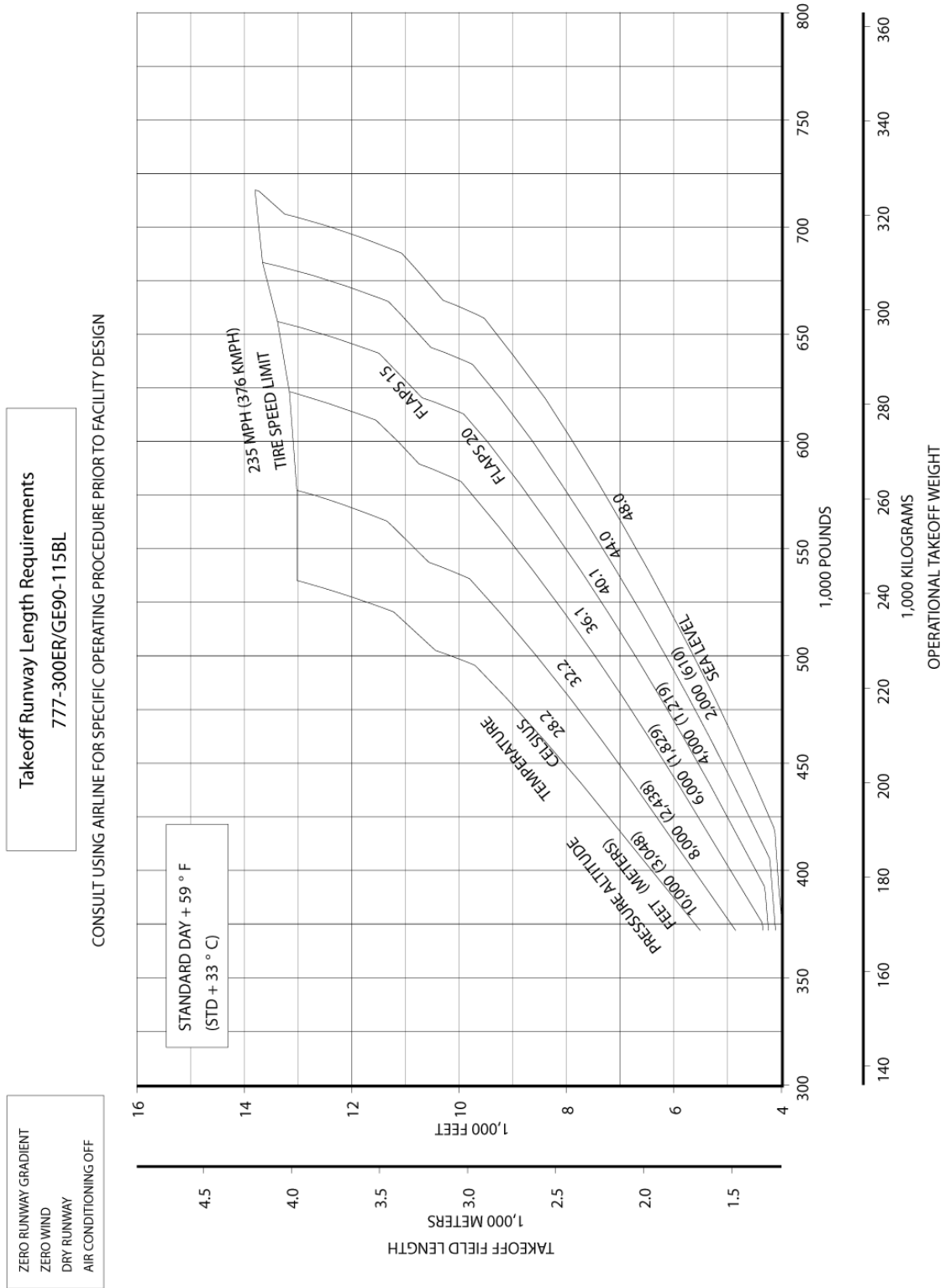

### 3.3.13 F.A.R. Takeoff Runway Length Requirements - Standard Day: Model 777F (GE90-110B1L Engines)

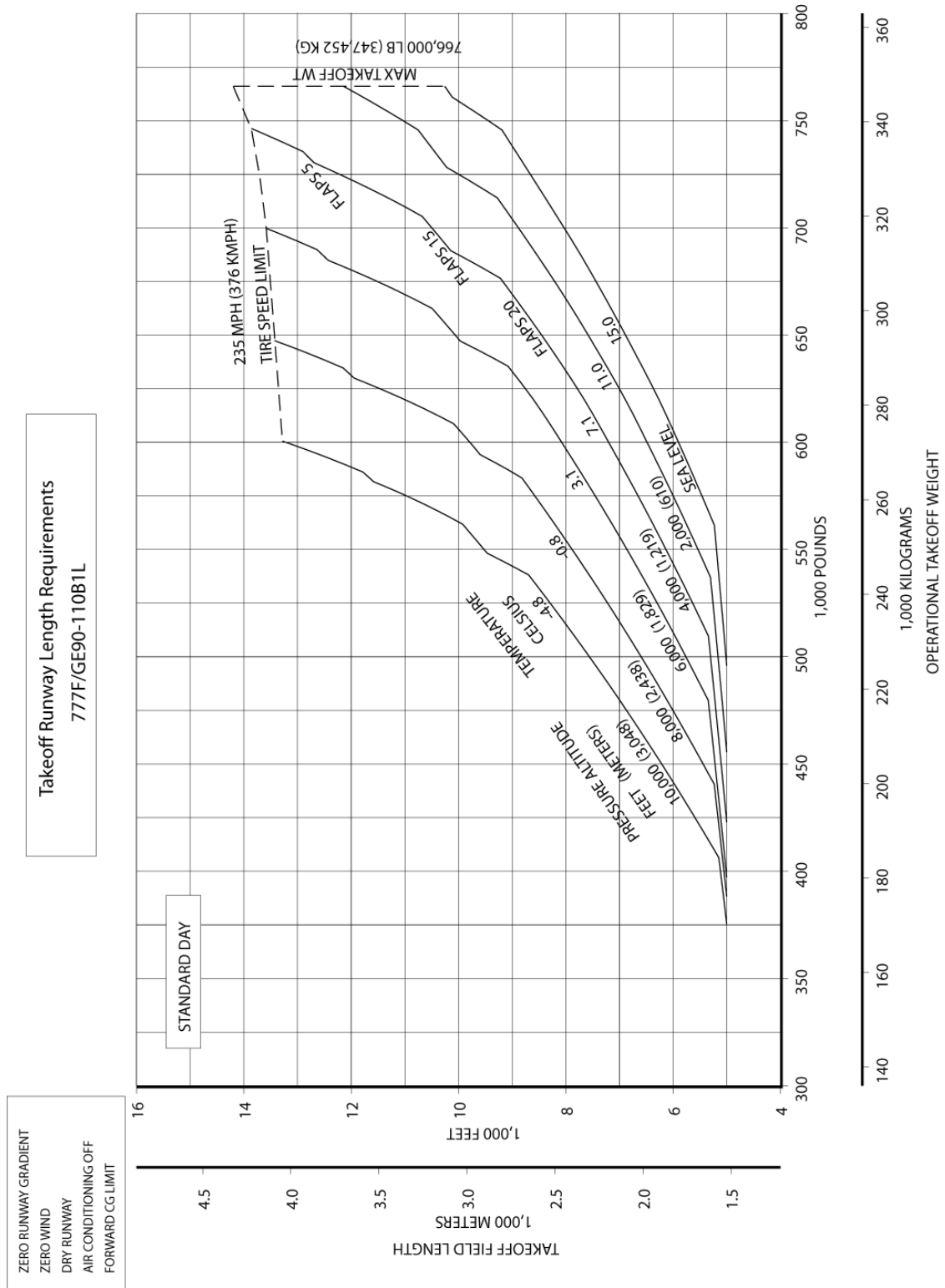

### 3.3.14 F.A.R. Takeoff Runway Length Requirements - Standard Day + 27°F (STD + 15°C): Model 777F (GE90-110B1L Engines)

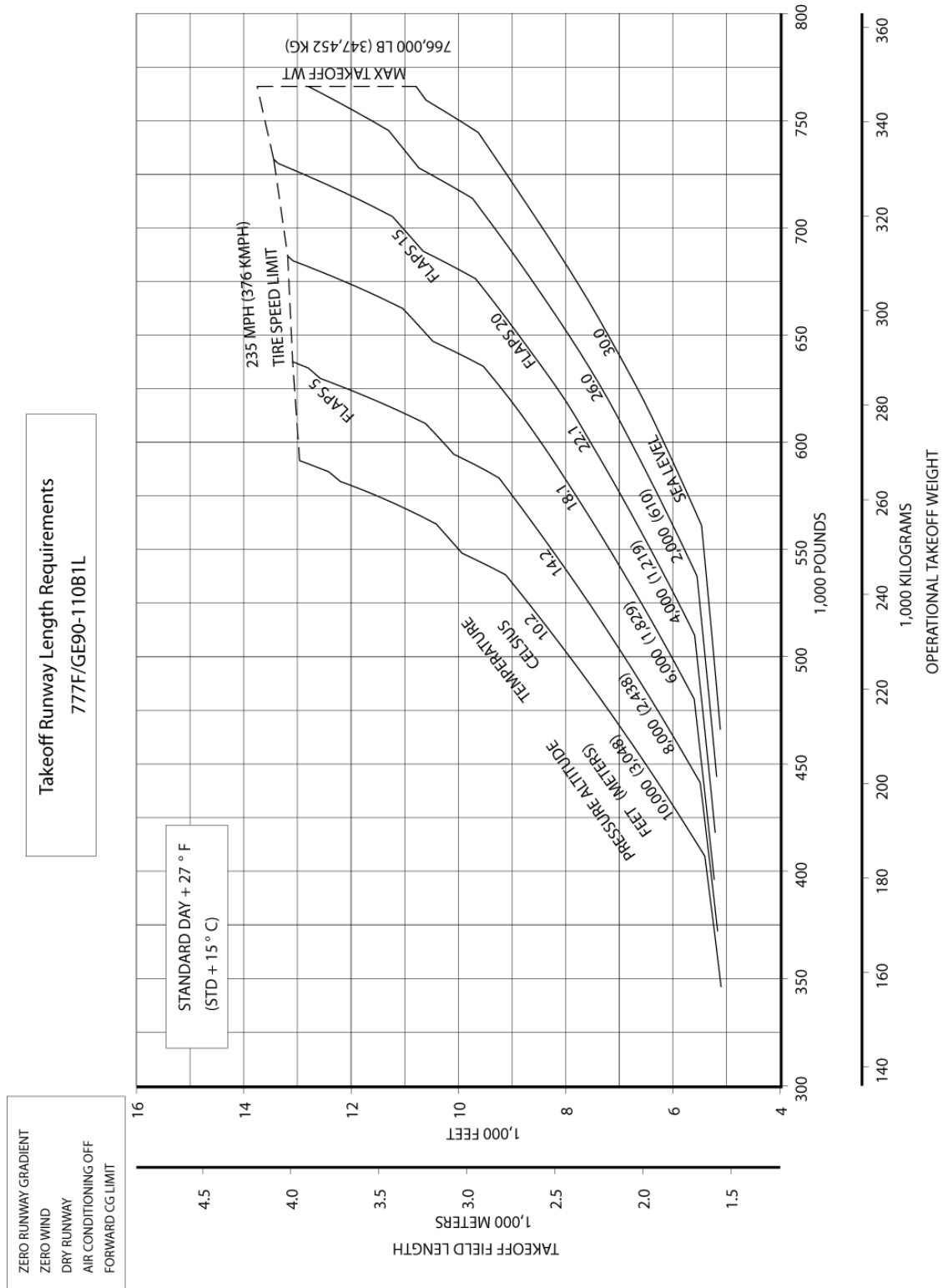

### 3.3.15 F.A.R. Takeoff Runway Length Requirements - Standard Day + 49°F (STD + 27°C): Model 777F (GE90-110B1L Engines)

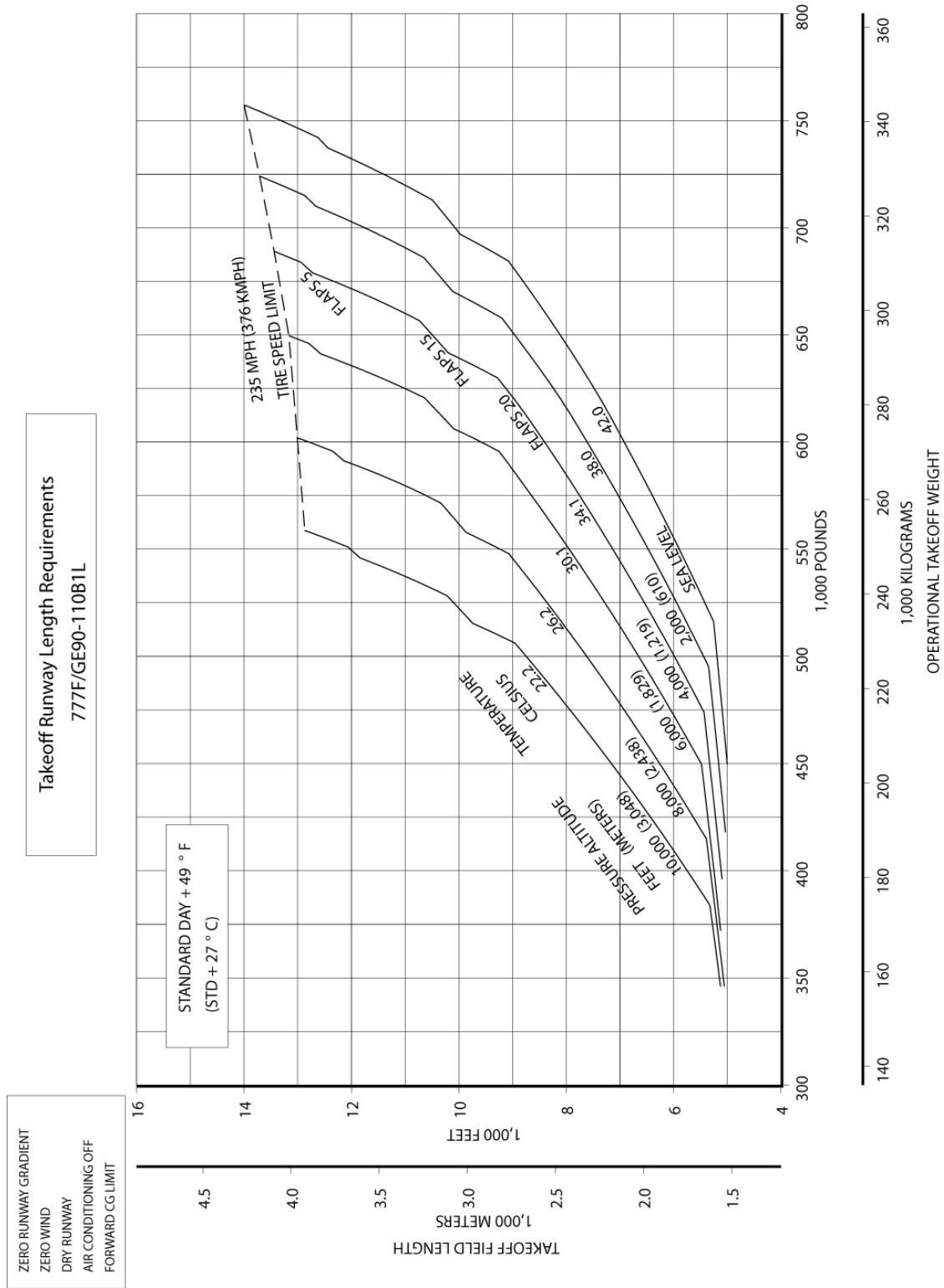

D6-58329-2



### 3.3.16 F.A.R. Takeoff Runway Length Requirements - Standard Day + 59°F (STD + 33°C): Model 777F (GE90-110B1L Engines)

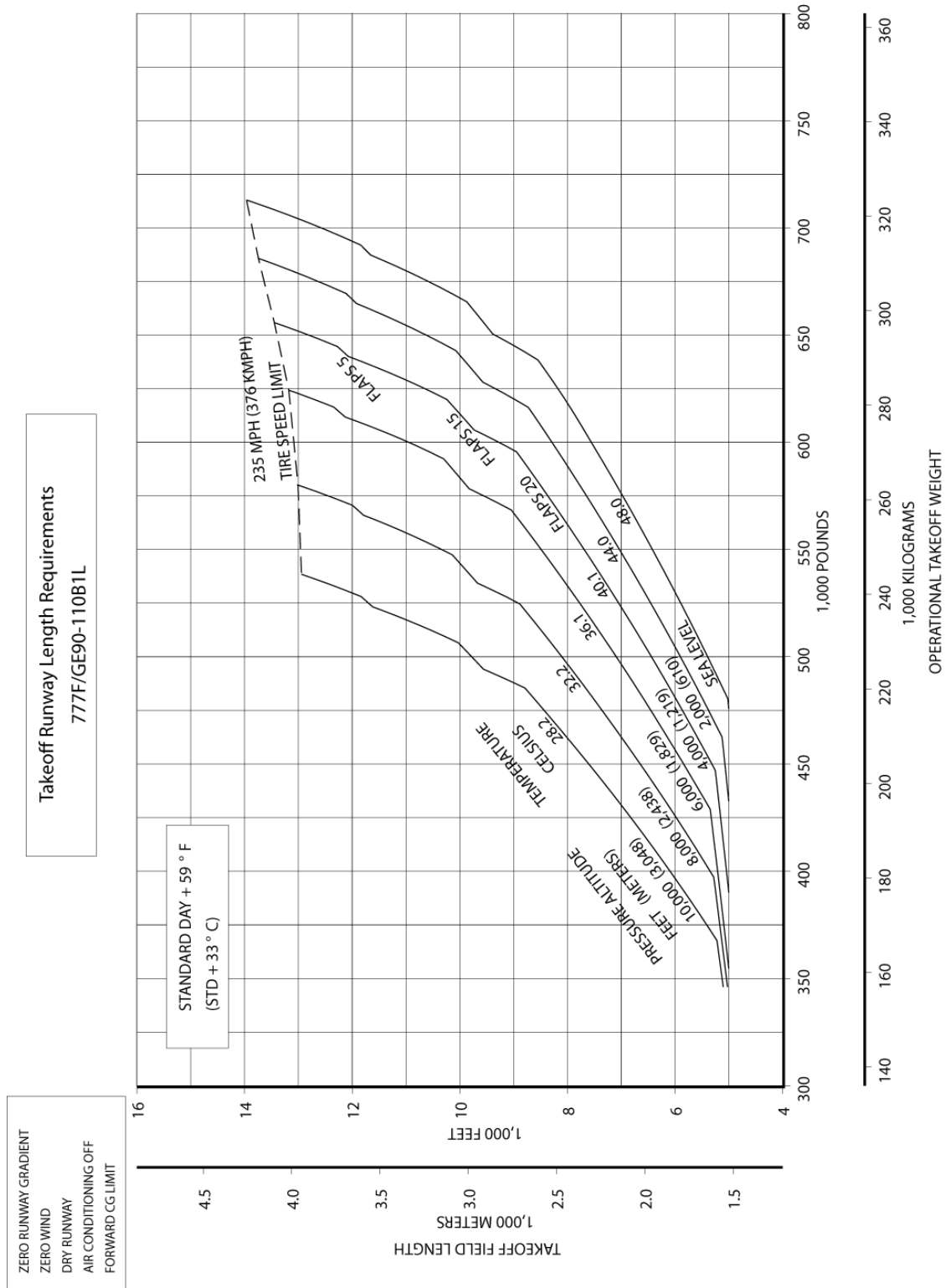

D6-58329-2

### 3.3.17 F.A.R. Takeoff Runway Length Requirements - Standard Day: Model 777F (GE90-115BL Engines)

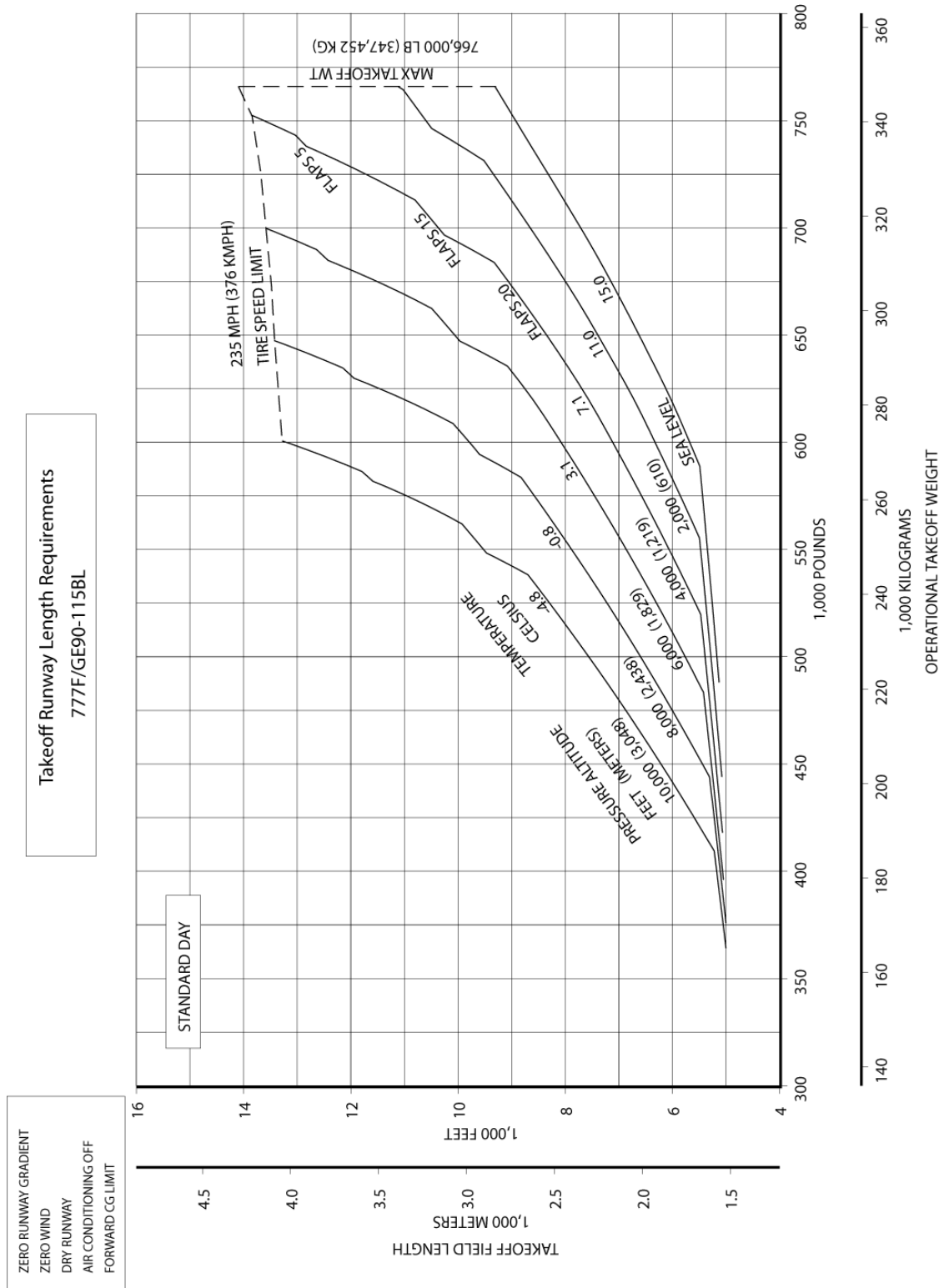

### 3.3.18 F.A.R. Takeoff Runway Length Requirements - Standard Day + 27°F (STD + 15°C): Model 777F (GE90-115BL Engines)

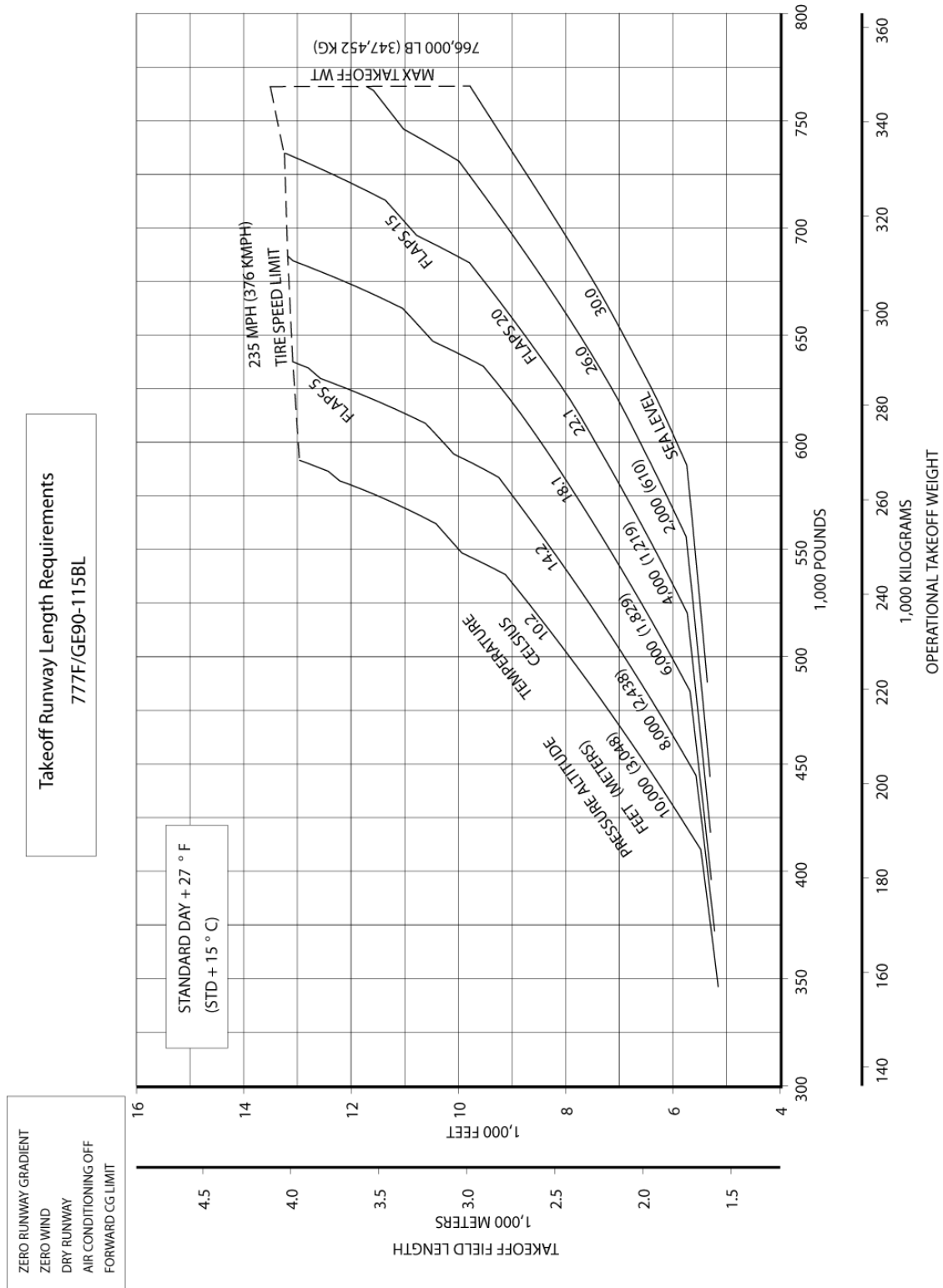

### 3.3.19 F.A.R. Takeoff Runway Length Requirements - Standard Day + 49°F (STD + 27°C): Model 777F (GE90-115BL Engines)

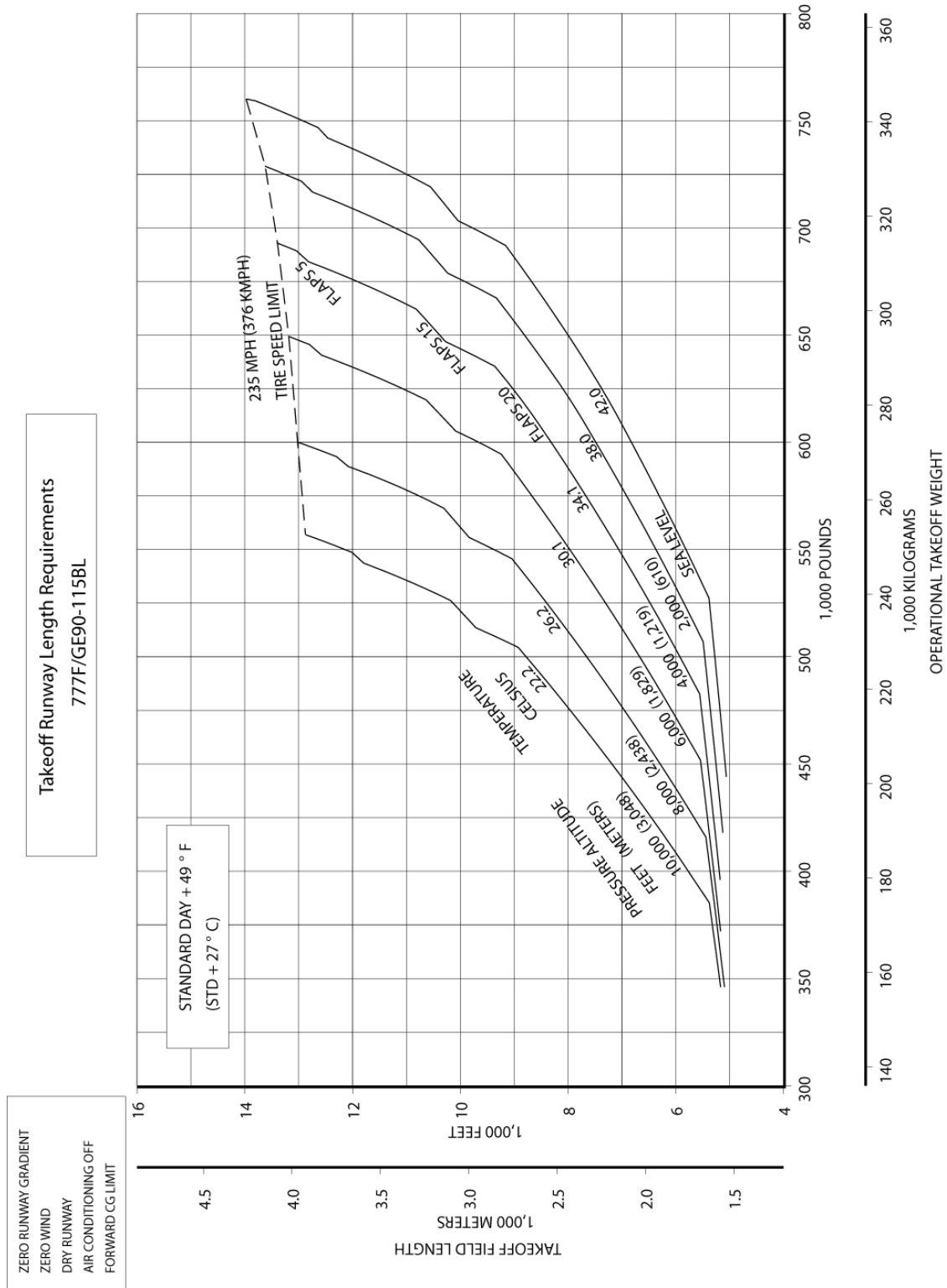

### 3.3.20 F.A.R. Takeoff Runway Length Requirements - Standard Day + 59°F (STD + 33°C): Model 777F (GE90-115BL Engines)

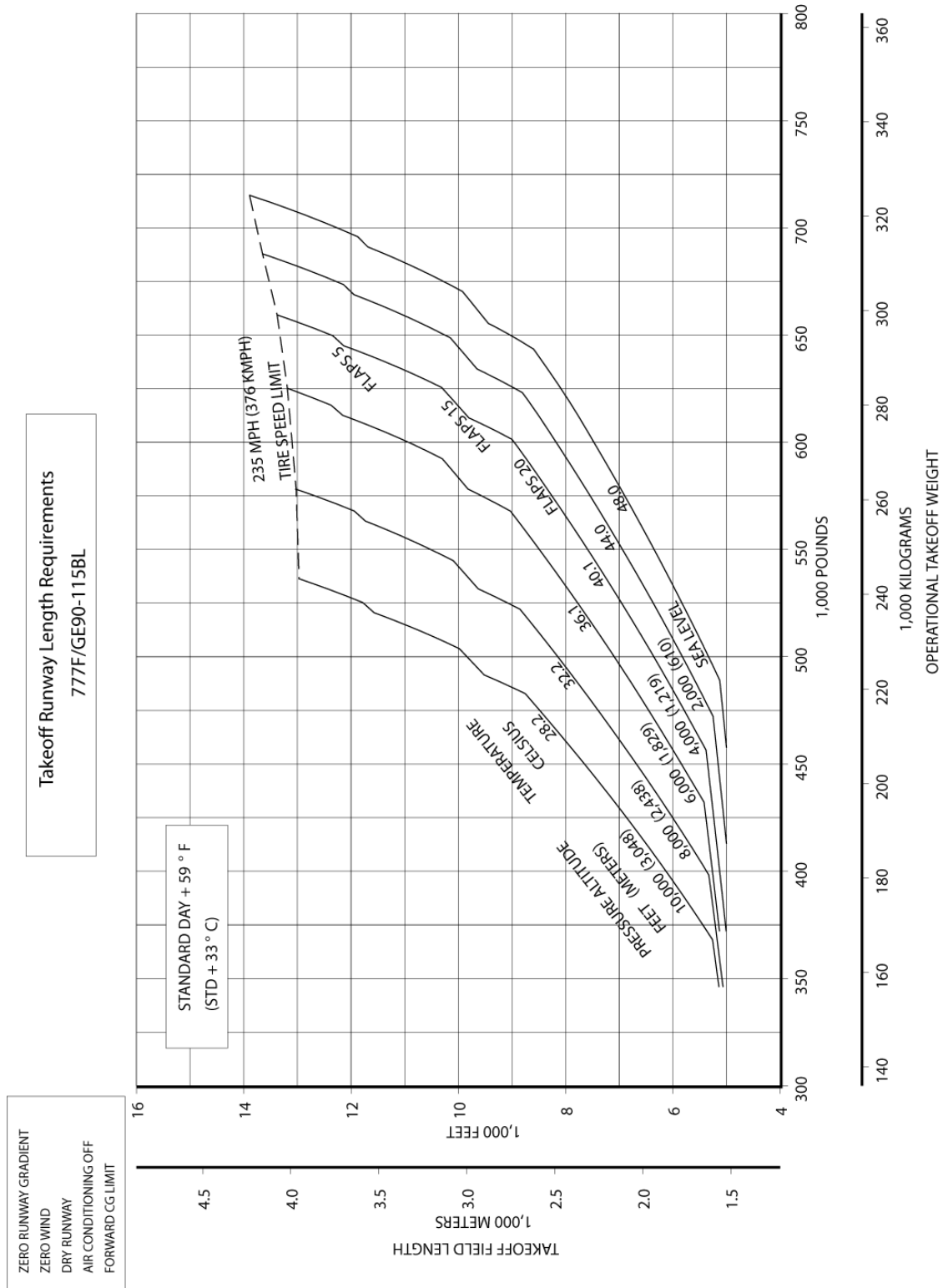

D6-58329-2

### 3.4 F.A.R. LANDING RUNWAY LENGTH REQUIREMENTS

#### 3.4.1 F.A.R. Landing Runway Length Requirements - Flaps 25: Model 777-200LR (GE90-110B1L Engines)

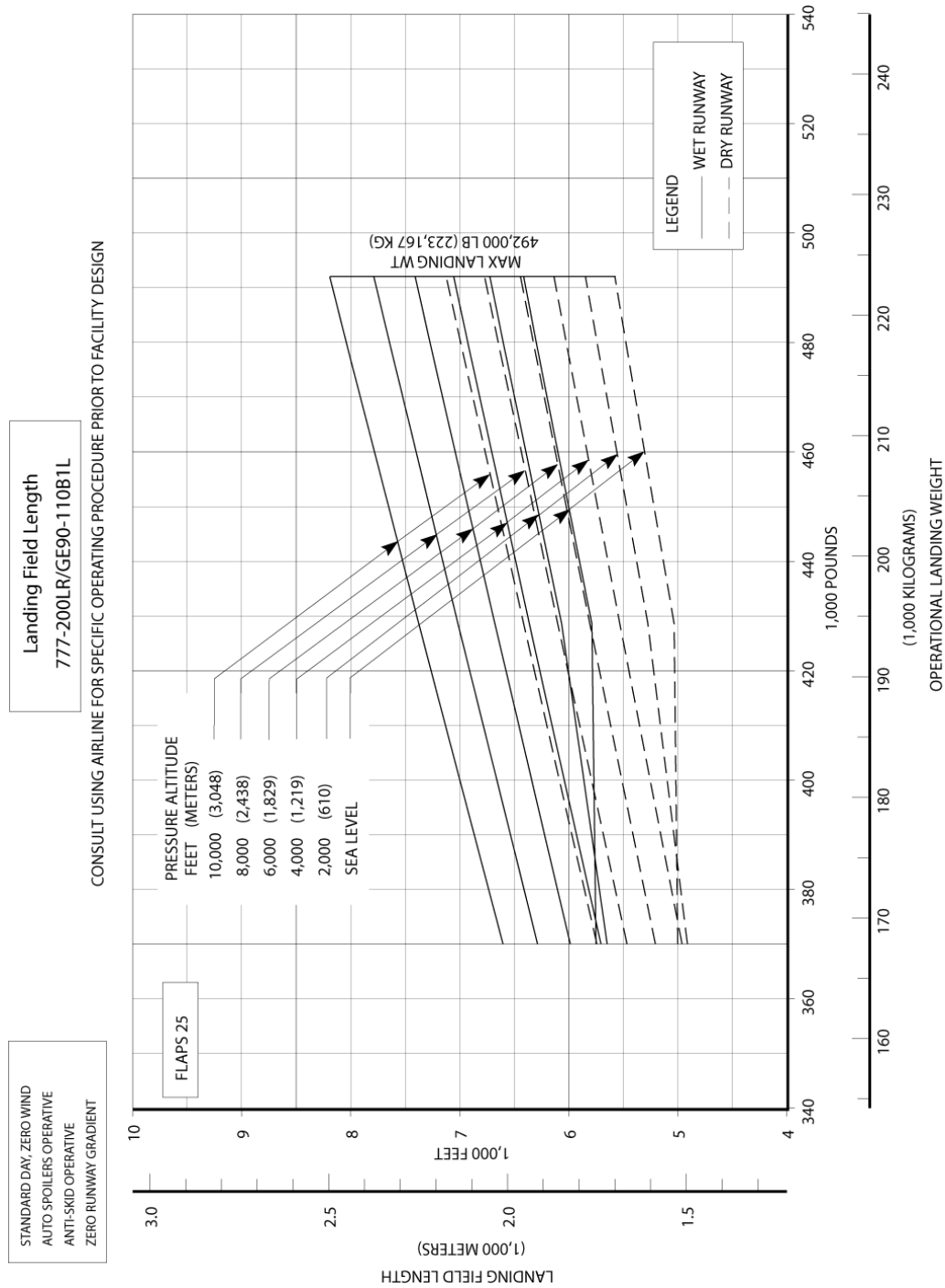

### 3.4.2 F.A.R. Landing Runway Length Requirements - Flaps 30: Model 777-200LR (GE90-110B1L Engines)

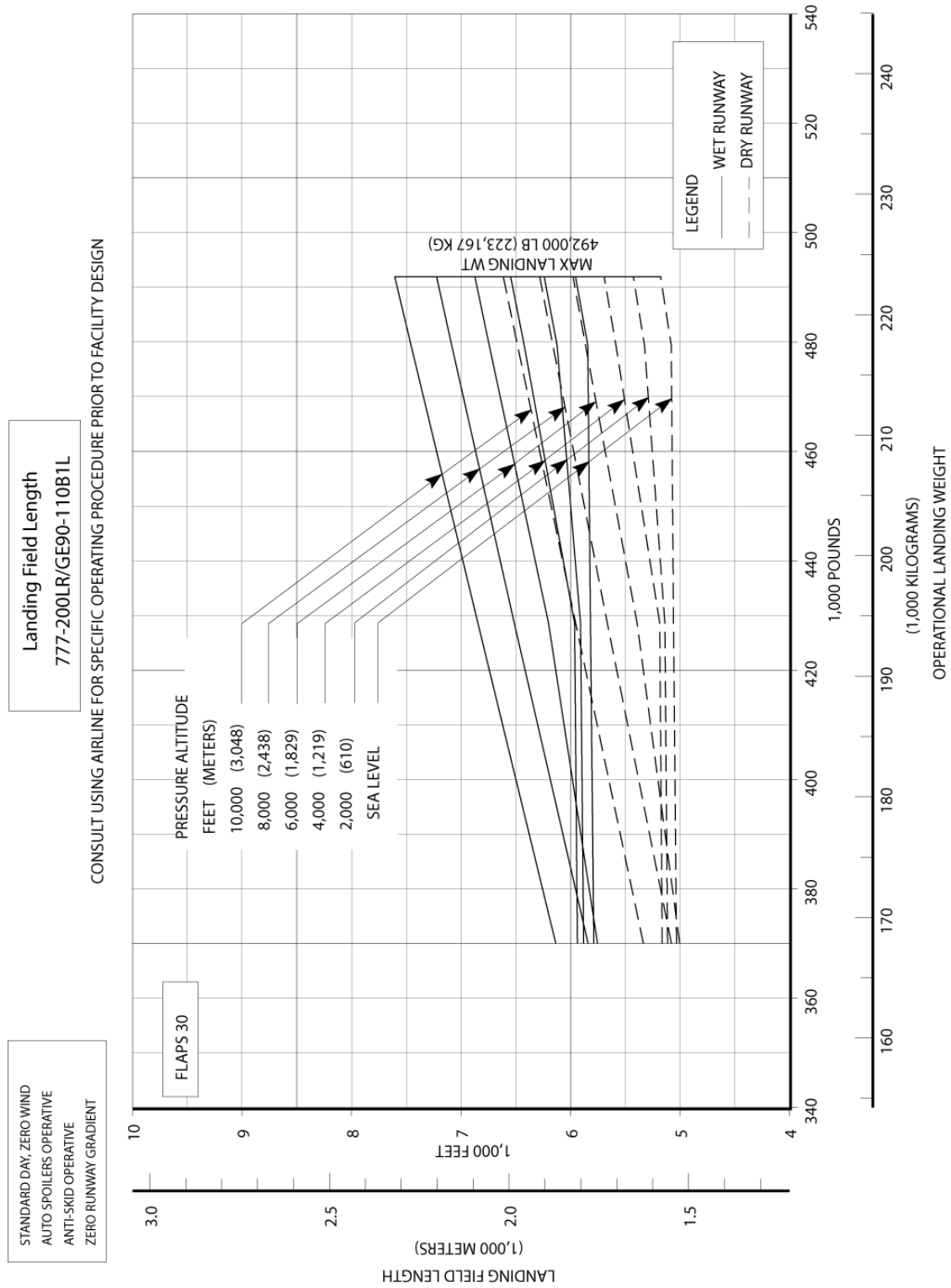

D6-58329-2

### 3.4.3 F.A.R. Landing Runway Length Requirements - Flaps 25: Model 777-200LR (GE90-115BL Engines)

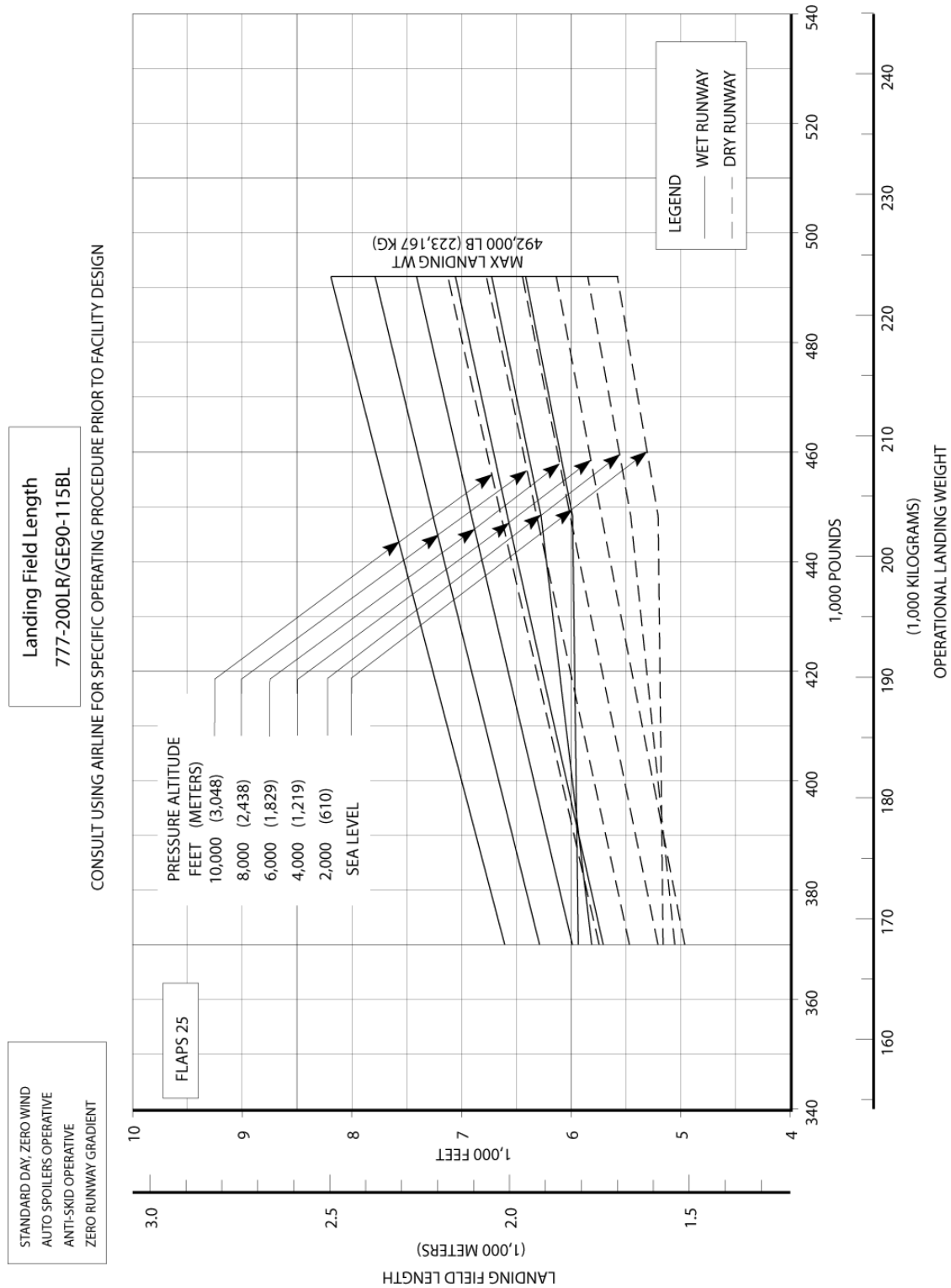



### 3.4.4 F.A.R. Landing Runway Length Requirements - Flaps 30: Model 777-200LR (GE90-115BL Engines)

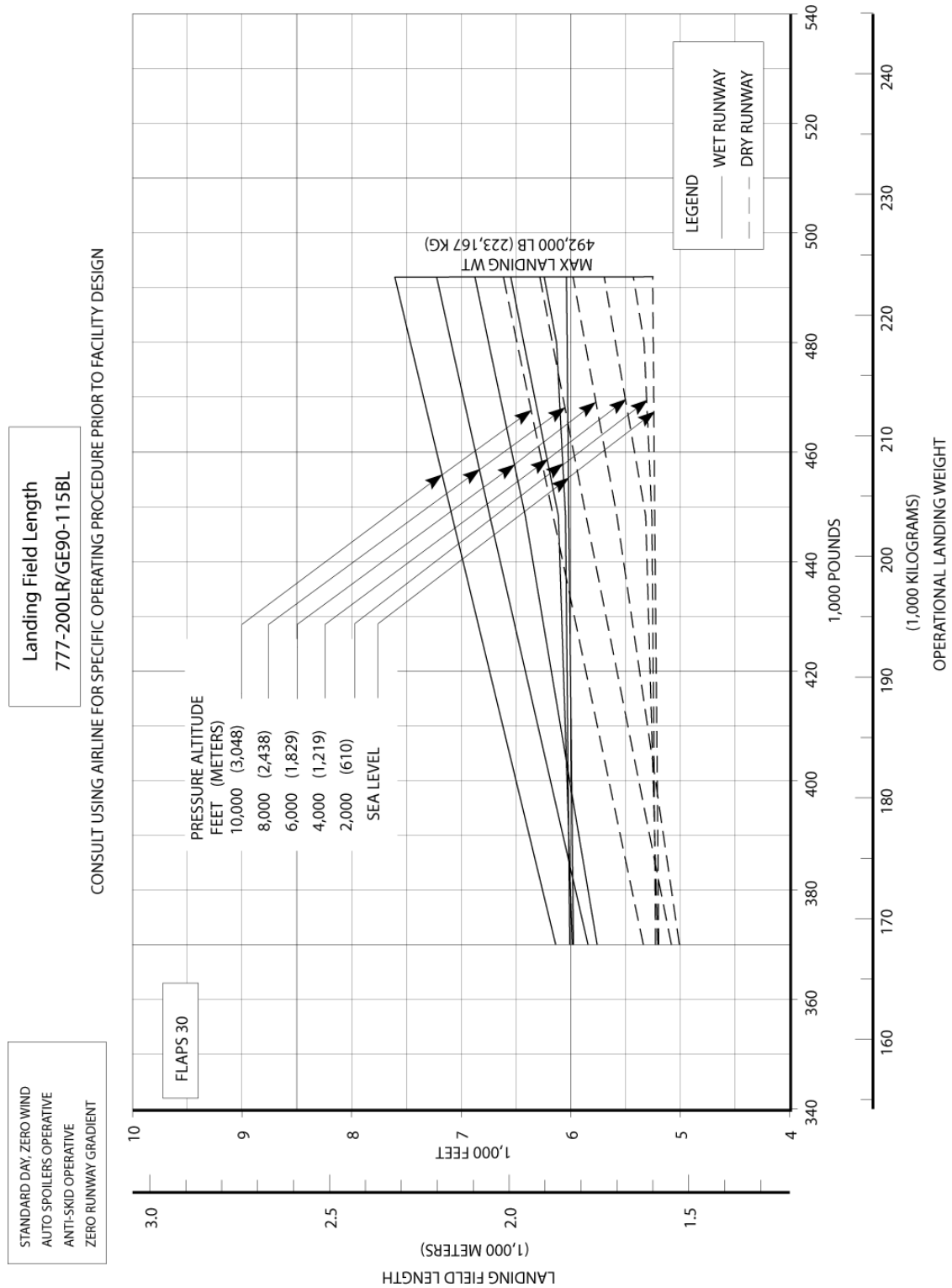

### 3.4.5 F.A.R. Landing Runway Length Requirements - Flaps 25: Model 777-300ER (GE90-115BL Engines)

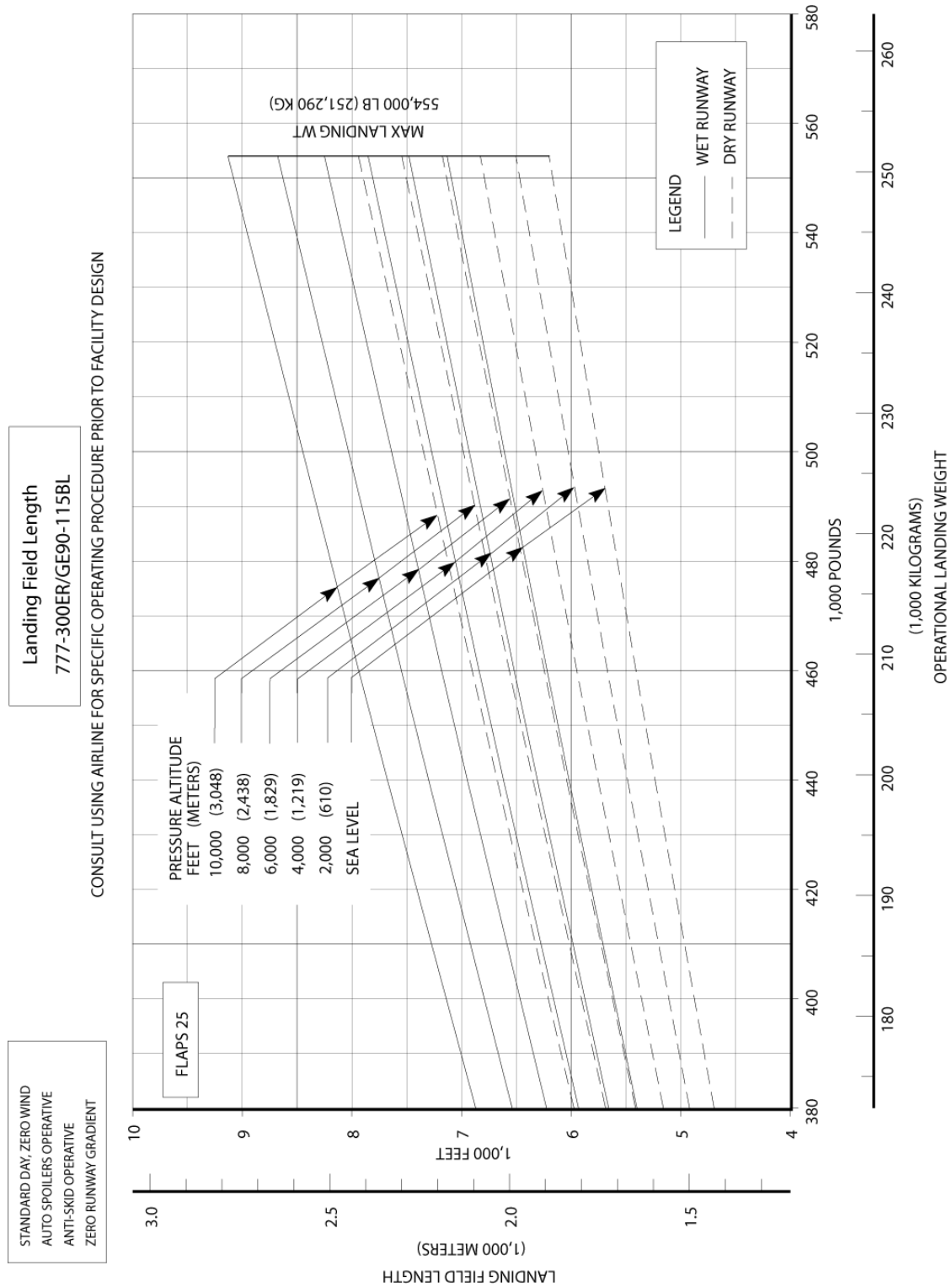

### 3.4.6 F.A.R. Landing Runway Length Requirements - Flaps 30: Model 777-300ER (GE90-115BL Engines)

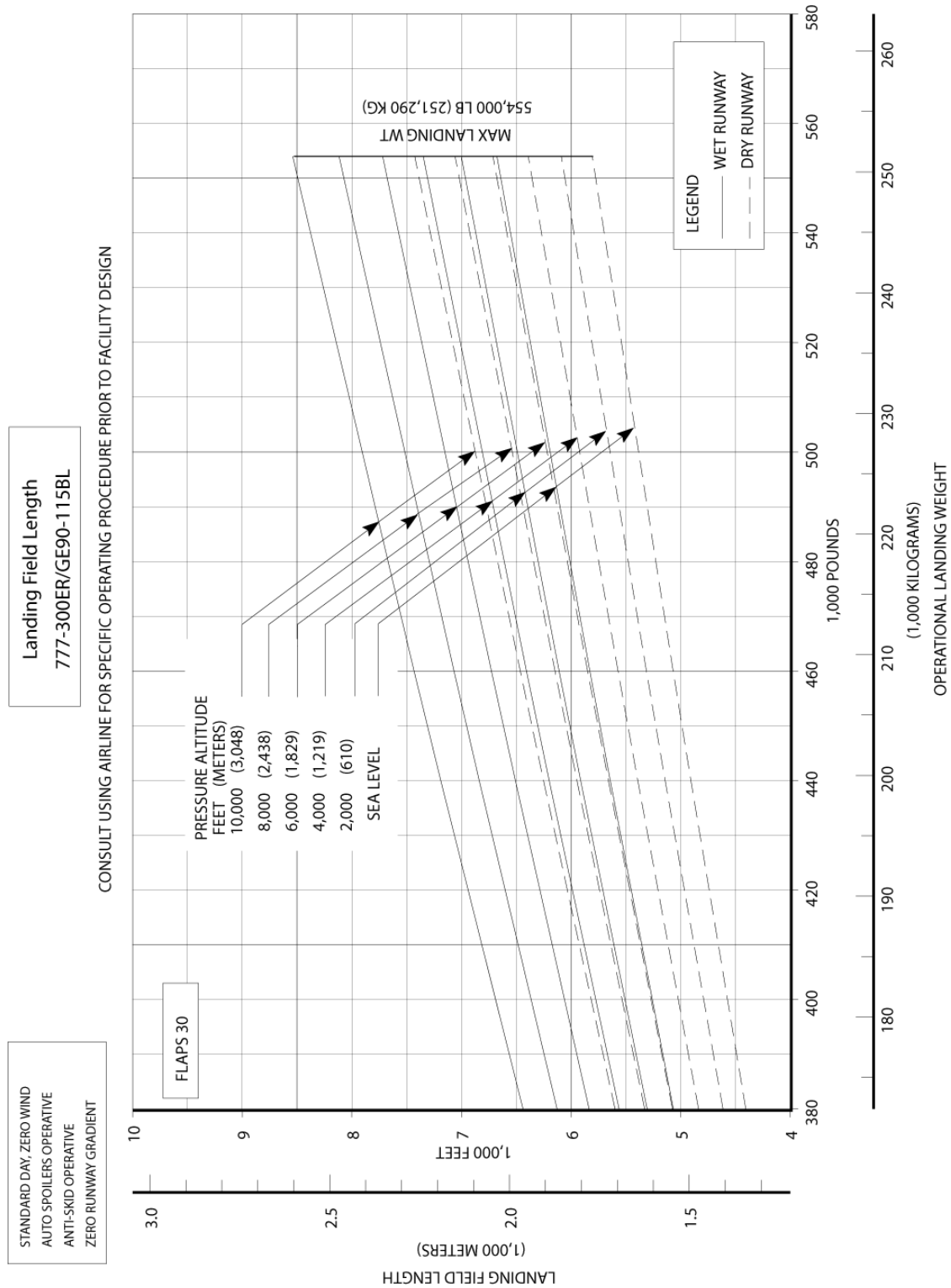

### 3.4.7 F.A.R. Landing Runway Length Requirements - Flaps 25: Model 777F (GE90-110B1L Engines)

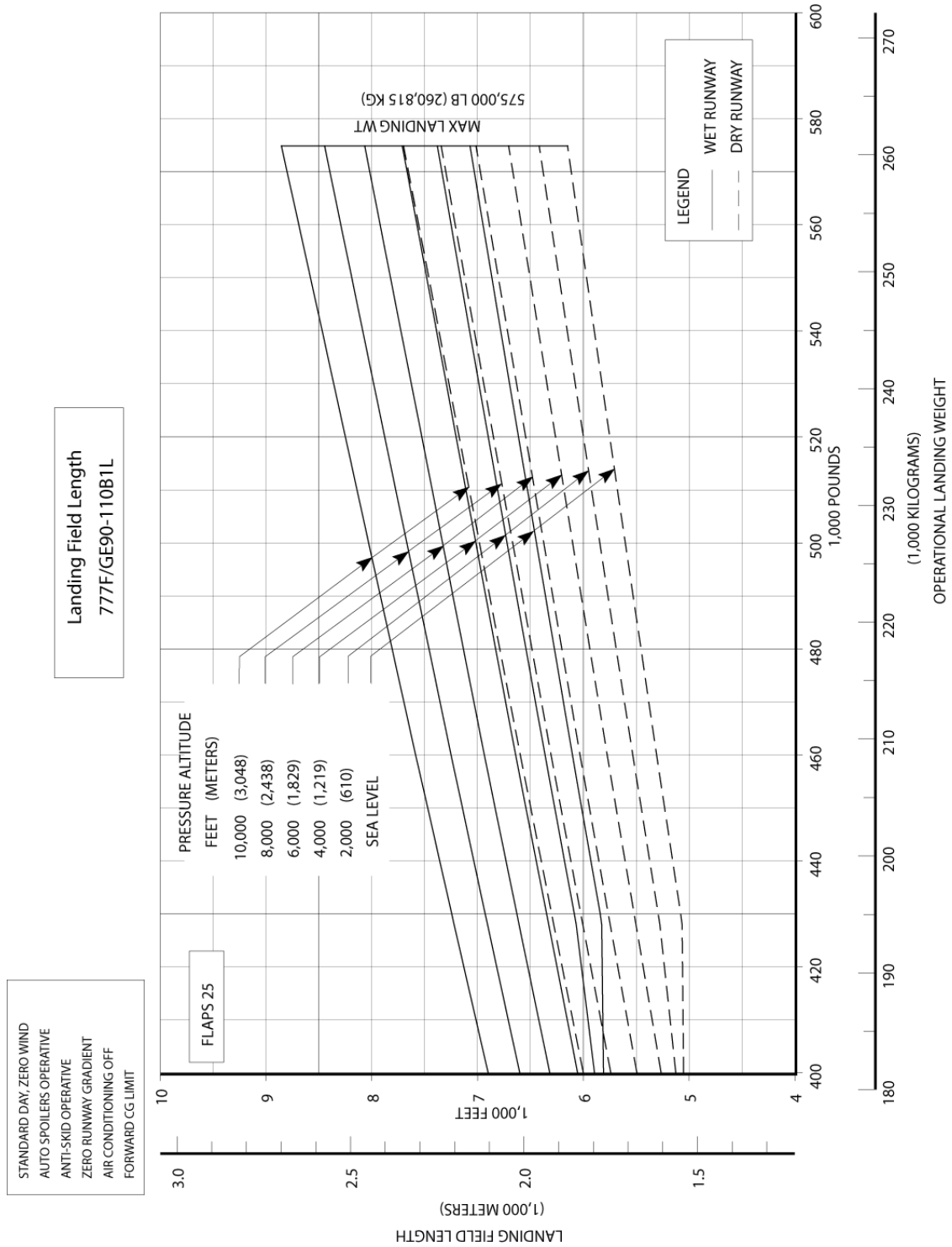

D6-58329-2

### 3.4.8 F.A.R. Landing Runway Length Requirements - Flaps 30: Model 777F (GE90-110B1L Engines)

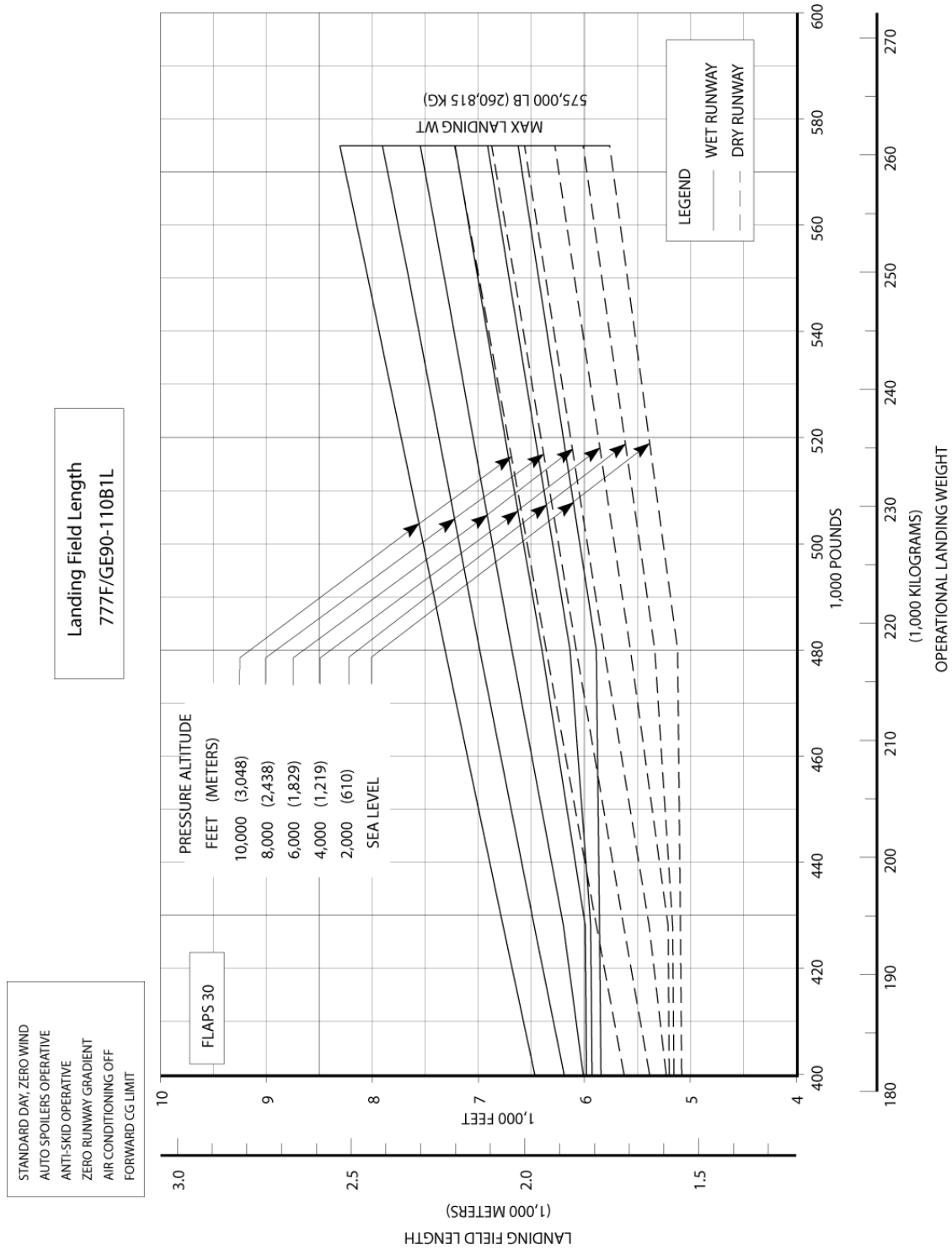

### 3.4.9 F.A.R. Landing Runway Length Requirements - Flaps 25: Model 777F (GE90-115BL Engines)

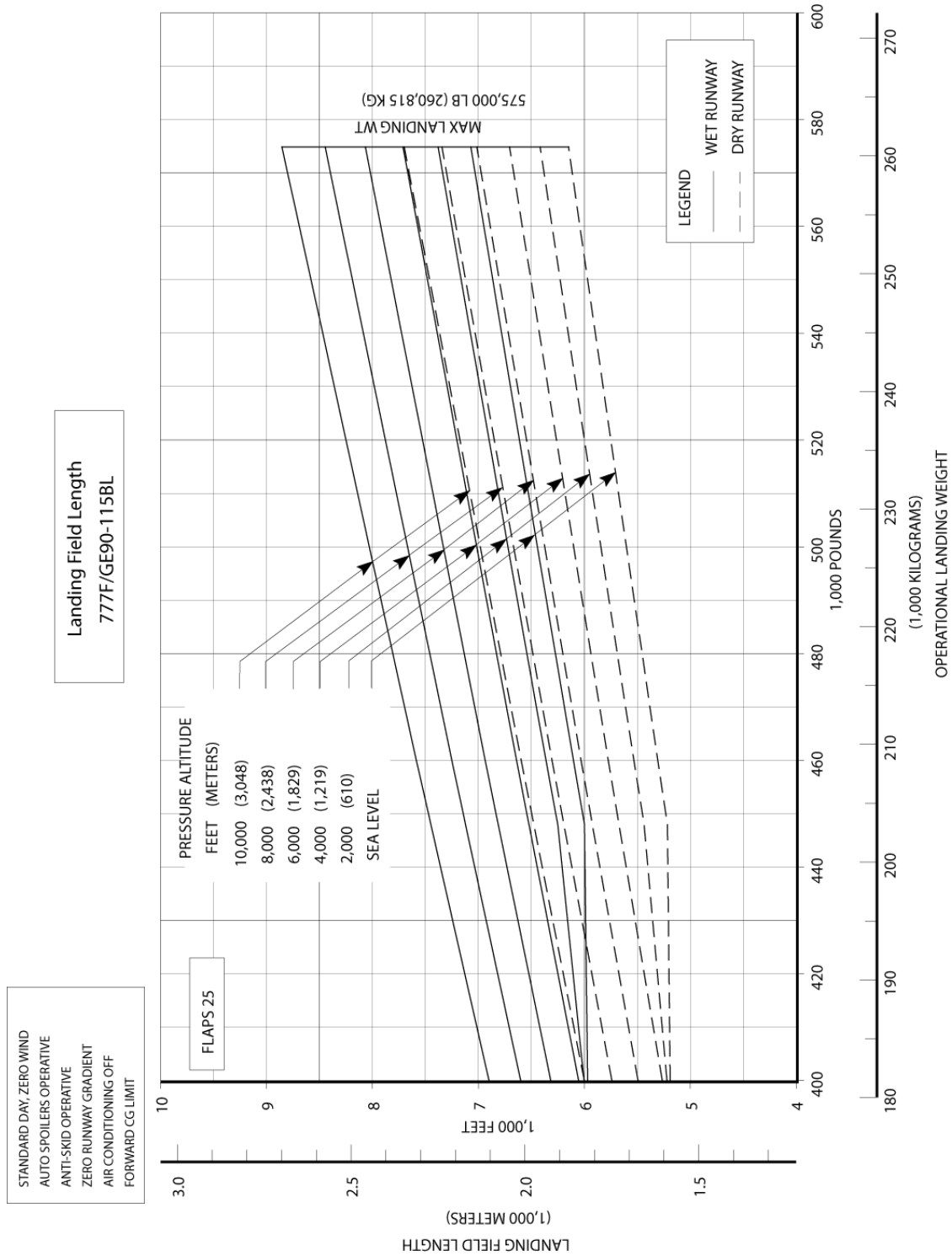

### 3.4.10 F.A.R. Landing Runway Length Requirements - Flaps 30: Model 777F (GE90-115BL Engines)

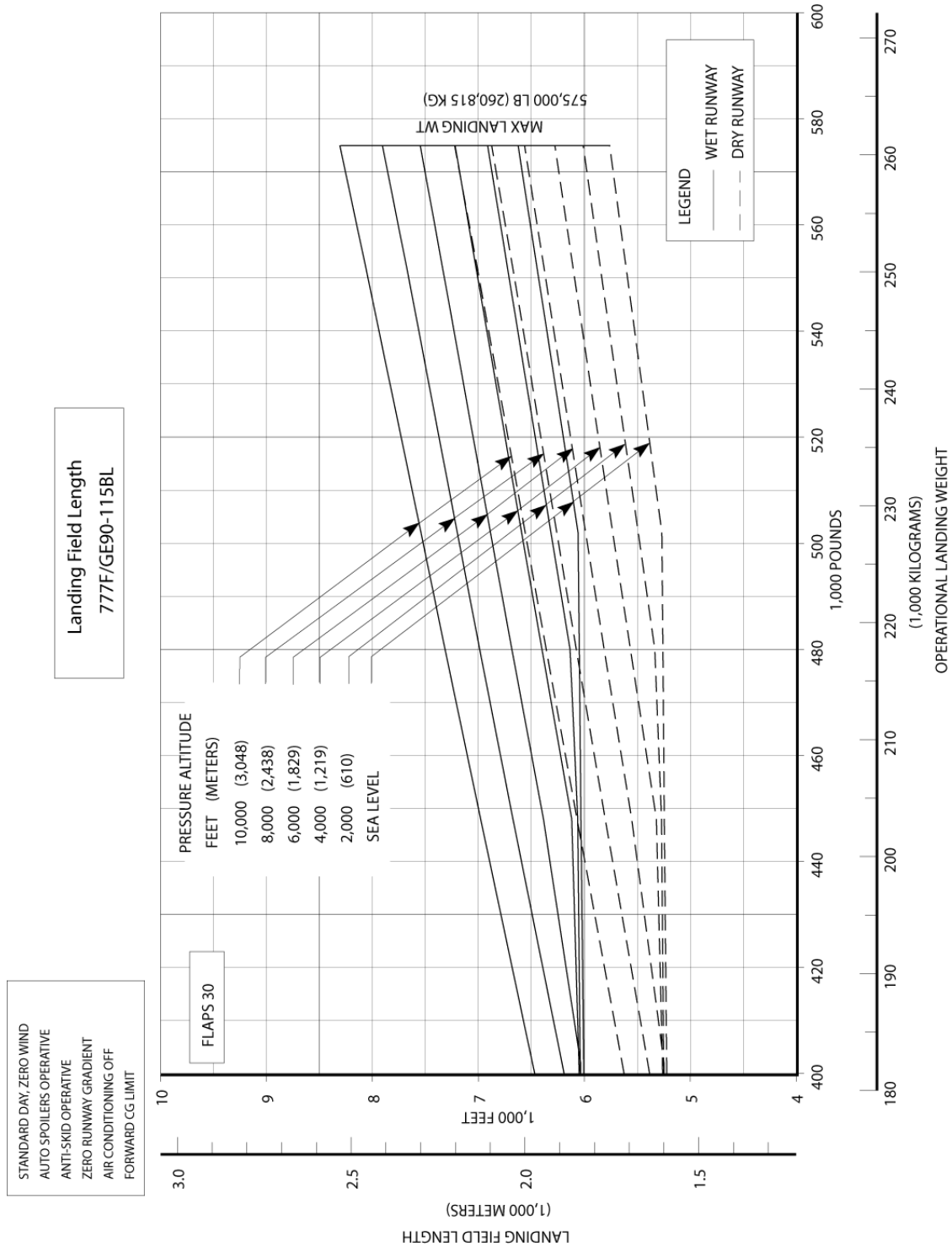

D6-58329-2

---

## 4.0 GROUND MANEUVERING

### 4.1 GENERAL INFORMATION

The 777 main landing gear consists of two main struts, each strut with six wheels. The steering system incorporates aft axle steering of the main landing gear in addition to the nose gear steering. The aft axle steering system is hydraulically actuated and programmed to provide steering ratios proportionate to the nose gear steering angles. During takeoff and landing, the aft axle steering system is centered, mechanically locked, and depressurized.

The turning radii and turning curves shown in this section are derived from airplane geometry. Other factors that could influence the geometry of the turn include:

1. Engine power settings
2. Center of gravity location
3. Airplane weight
4. Pavement surface conditions
5. Amount of differential braking
6. Ground speed

This section provides airplane turning capability and maneuvering characteristics.

For ease of presentation, these data have been determined from the theoretical limits imposed by the geometry of the aircraft, and where noted, provide for a normal allowance for tire slippage. As such, they reflect the turning capability of the aircraft in favorable operating circumstances. These data should be used only as guidelines for the method of determination of such parameters and for the maneuvering characteristics of this aircraft.

In the ground operating mode, varying airline practices may demand that more conservative turning procedures be adopted to avoid excessive tire wear and reduce possible maintenance problems. Airline operating procedures will vary in the level of performance over a wide range of operating circumstances throughout the world. Variations from standard aircraft operating patterns may be necessary to satisfy physical constraints within the maneuvering area, such as adverse grades, limited area, or high risk of jet blast damage. For these reasons, ground maneuvering requirements should be coordinated with the using airlines prior to layout planning.

Section 4.2 presents turning radii for various nose gear steering angles. Radii for the main and nose gears are measured from the turn center to the outside of the tire.

Section 4.3 shows data on minimum width of pavement required for 180° turn.



---

Section 4.4 provides pilot visibility data from the cockpit and the limits of ambbinocular vision through the windows. Ambinocular vision is defined as the total field of vision seen simultaneously by both eyes.

Section 4.5 shows approximate wheel paths for various runway and taxiway turn scenarios. The pavement fillet geometries are based on the FAA's Advisory Circular (AC) 150/5300-13 (thru change 16). They represent typical fillet geometries built at many airports worldwide. ICAO and other civil aviation authorities publish many different fillet design methods. Prior to determining the size of fillets, airports are advised to check with the airlines regarding the operating procedures and aircraft types they expect to use at the airport. Further, given the cost of modifying fillets and the operational impact to ground movement and air traffic during construction, airports may want to design critical fillets for larger aircraft types to minimize future operational impacts.

Section 4.6 illustrates a typical runway holding bay configuration.

## 4.2 TURNING RADII

### 4.2.1 Turning Radii – No Slip Angle: Model 777-200LR, 777F

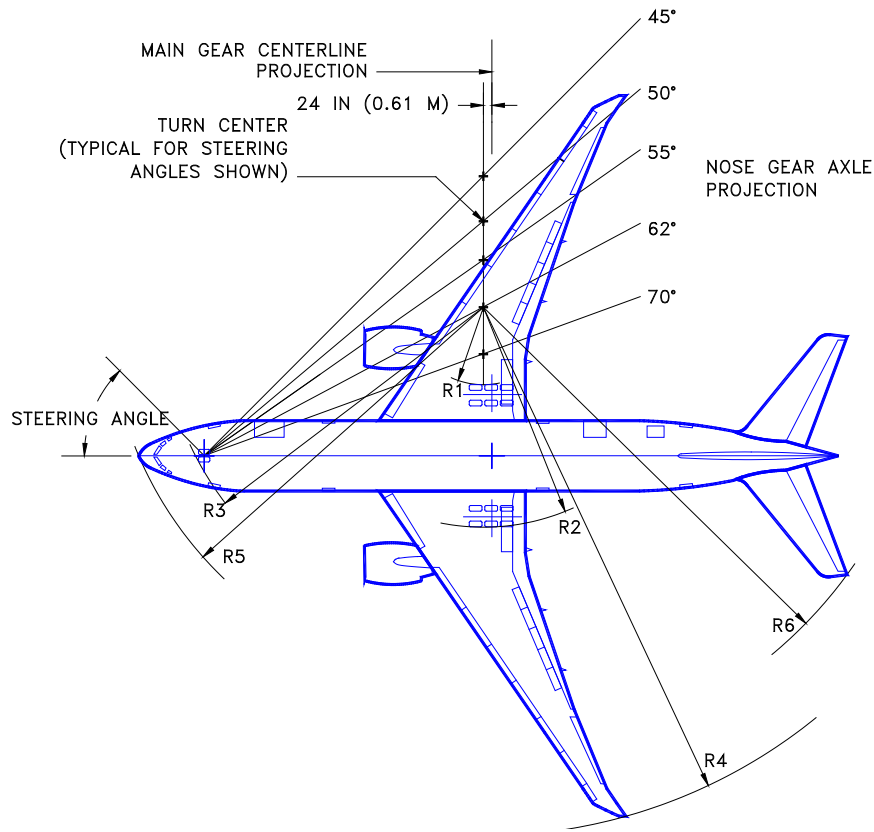

**NOTES:** DATA SHOWN FOR AIRPLANE WITH AFT AXLE STEERING  
 ACTUAL OPERATING TURNING RADII MAY BE GREATER THAN SHOWN  
 CONSULT WITH AIRLINE FOR SPECIFIC OPERATING PROCEDURE  
 DIMENSIONS ROUNDED TO NEAREST 0.1 FOOT AND 0.1 METER

STEERING ANGLE (DEG)	R1 INNER GEAR		R2 OUTER GEAR		R3 NOSE GEAR		R4 WINGTIP		R5 NOSE		R6 TAIL	
	FT	M	FT	M	FT	M	FT	M	FT	M	FT	M
30	122.4	37.3	164.8	50.2	168.8	51.5	253.0	77.1	177.4	54.1	207.4	63.2
35	97.2	29.6	139.6	42.6	147.7	45.0	228.1	69.5	157.7	48.1	186.1	56.7
40	77.6	23.7	120.0	36.6	132.3	40.3	208.8	63.6	143.6	43.8	170.3	51.9
45	61.7	18.8	104.1	31.7	120.7	36.8	193.3	58.9	133.2	40.6	158.0	48.2
50	48.4	14.8	90.8	27.7	111.8	34.1	180.2	54.9	125.3	38.2	148.3	45.2
55	36.8	11.2	79.2	24.1	104.8	31.9	169.0	51.5	119.3	36.4	140.4	42.8
60	26.7	8.1	69.1	21.1	99.5	30.3	159.1	48.5	114.7	35.0	133.9	40.8
65	17.5	5.3	59.9	18.3	95.3	29.0	150.2	45.8	111.1	33.9	128.3	39.1
70 (MAX)	9.0	2.7	51.4	15.7	92.1	28.1	142.0	43.3	108.5	33.1	123.7	37.7

## 4.2.2 Turning Radii – No Slip Angle: Model 777-300ER

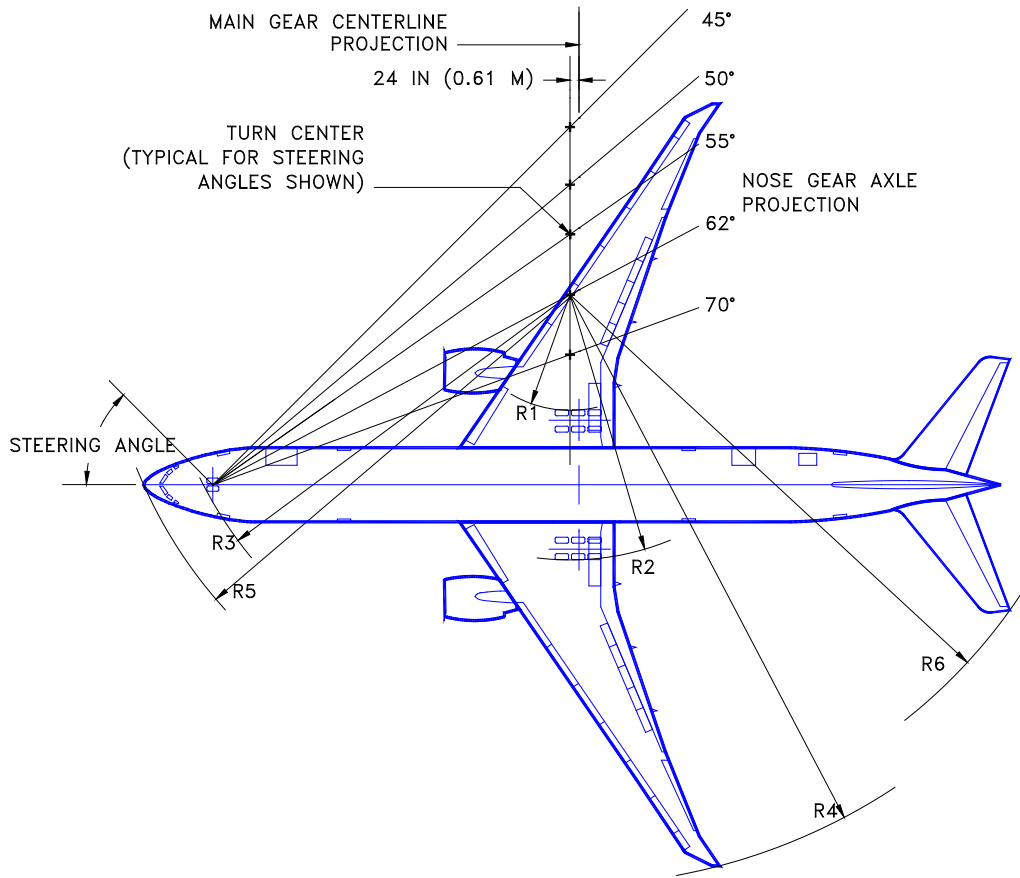

**NOTES:** DATA SHOWN FOR AIRPLANE WITH AFT AXLE STEERING  
 ACTUAL OPERATING TURNING RADII MAY BE GREATER THAN SHOWN  
 CONSULT WITH AIRLINE FOR SPECIFIC OPERATING PROCEDURE  
 DIMENSIONS ROUNDED TO NEAREST 0.1 FOOT AND 0.1 METER

STEERING ANGLE (DEG)	R1 INNER GEAR		R2 OUTER GEAR		R3 NOSE GEAR		R4 WINGTIP		R5 NOSE		R6 TAIL	
	FT	M	FT	M	FT	M	FT	M	FT	M	FT	M
30	152.7	46.5	195.1	59.5	203.8	62.1	283.3	86.4	212.3	64.7	241.5	73.6
35	122.2	37.2	164.6	50.2	178.2	54.3	252.8	77.1	188.1	57.3	215.6	65.7
40	98.5	30.0	140.9	42.9	159.5	48.6	229.4	69.9	170.7	52.0	196.4	59.9
45	79.2	24.1	121.6	37.1	145.4	44.3	210.4	64.1	157.8	48.1	181.5	55.3
50	63.0	19.2	106.5	32.4	134.6	41.0	194.6	59.3	148.0	45.1	169.4	51.6
55	49.1	15.0	91.5	27.9	126.2	38.5	180.9	55.1	140.5	42.8	160.3	48.9
60	36.8	11.2	79.2	24.1	119.7	36.5	168.9	51.5	134.8	41.1	152.5	46.5
65	25.6	7.8	68.0	20.7	114.6	34.9	158.1	48.2	130.4	39.7	145.9	44.5
70 (MAX)	15.3	4.7	57.7	17.6	110.7	33.7	148.2	45.2	124.6	38.0	140.4	42.8

### 4.3 CLEARANCE RADII: MODEL 777-200LR, -300ER, 777F

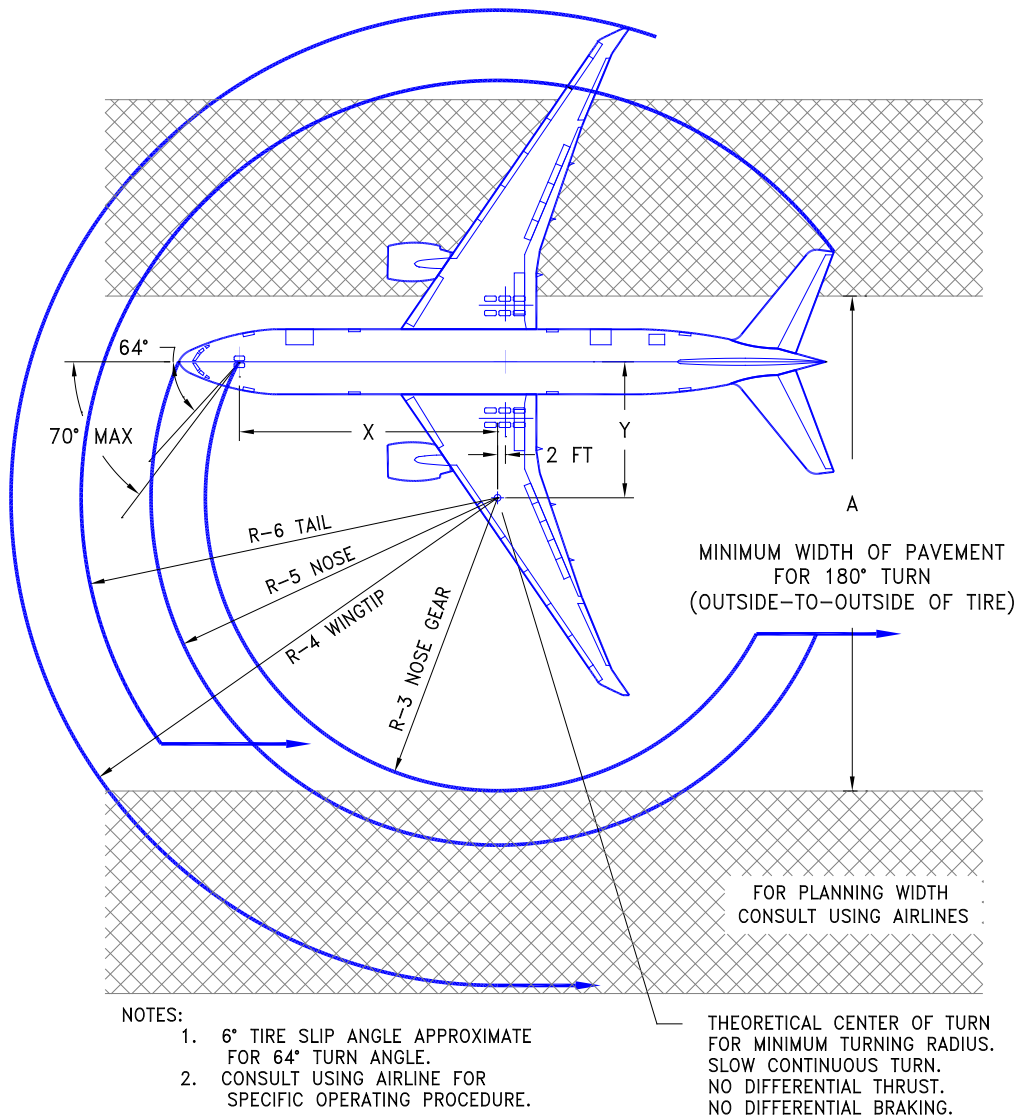

AIRPLANE MODEL	EFFECTIVE TURNING ANGLE (DEG)	X		Y		A		R3		R4		R5		R6	
		FT	M	FT	M	FT	M	FT	M	FT	M	FT	M	FT	M
777-200LR 777-FREIGHTER	64	82.9	25.3	40.4	12.3	157.4	48.0	96.0	29.3	151.9	46.3	111.8	34.1	129.4	39.4
777-300ER	64	100.4	30.6	49.0	14.9	185.5	56.5	115.5	35.2	160.2	48.8	131.2	40.0	147.1	44.8

**NOTE:** DIMENSIONS ARE ROUNDED TO THE NEAREST 0.1 FOOT AND 0.1 METER.

#### 4.4 VISIBILITY FROM COCKPIT IN STATIC POSITION: MODEL 777-200LR, -300ER, 777F

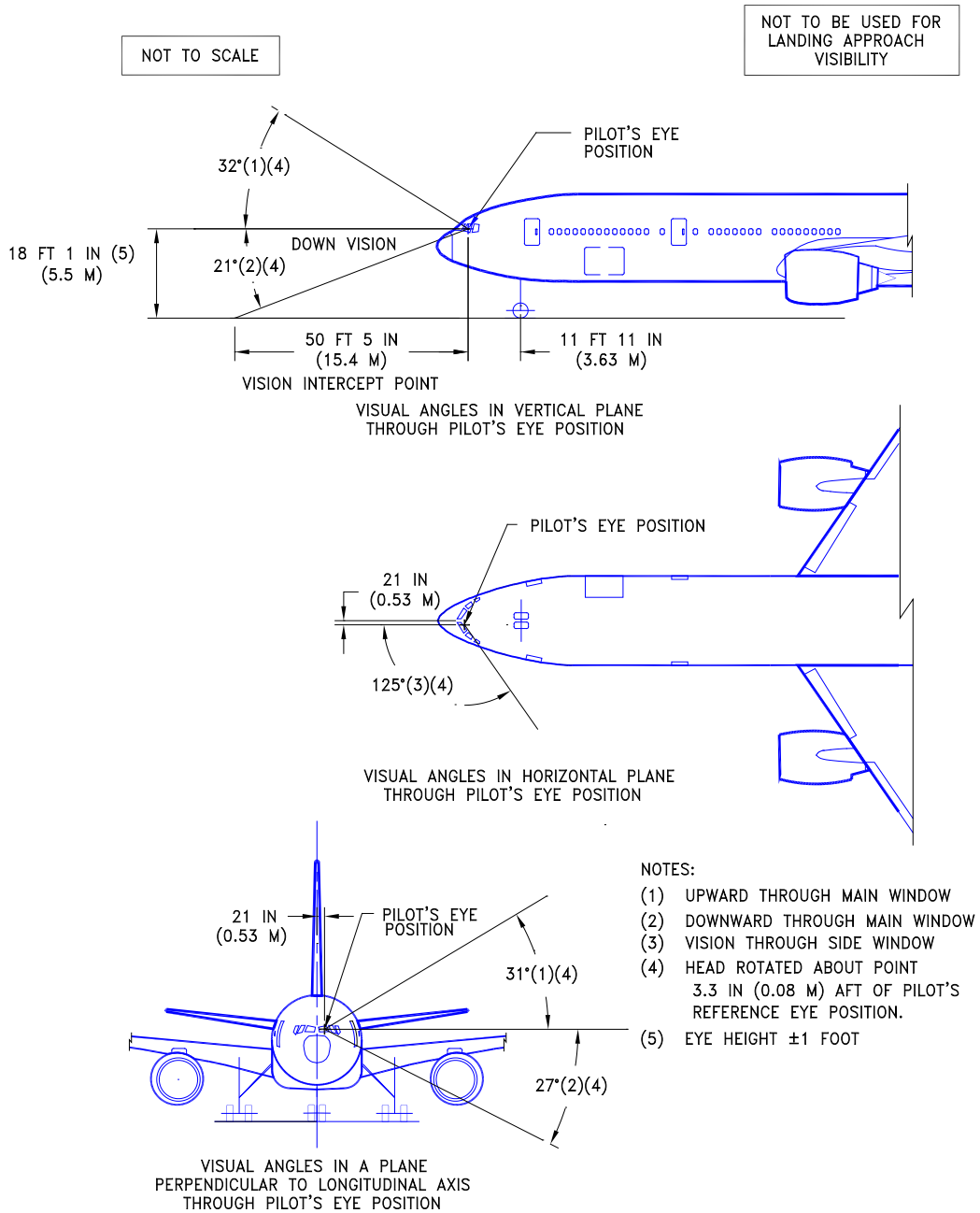

## 4.5 RUNWAY AND TAXIWAY TURN PATHS

### 4.5.1 Runway and Taxiway Turn Paths - Runway-to-Taxiway, More Than 90 Degrees: Model 777-200LR, -300ER, 777F

#### NOTES:

- BEFORE DETERMINING THE SIZE OF THE INTERSECTION FILLET, CHECK WITH THE AIRLINES REGARDING THE OPERATING PROCEDURES THAT THEY USE AND THE AIRCRAFT TYPES THEY ARE EXPECTED TO USE AT THE AIRPORT
- 777-300ER DATA SHOWN. 777F DATA IS LESS STRINGENT.

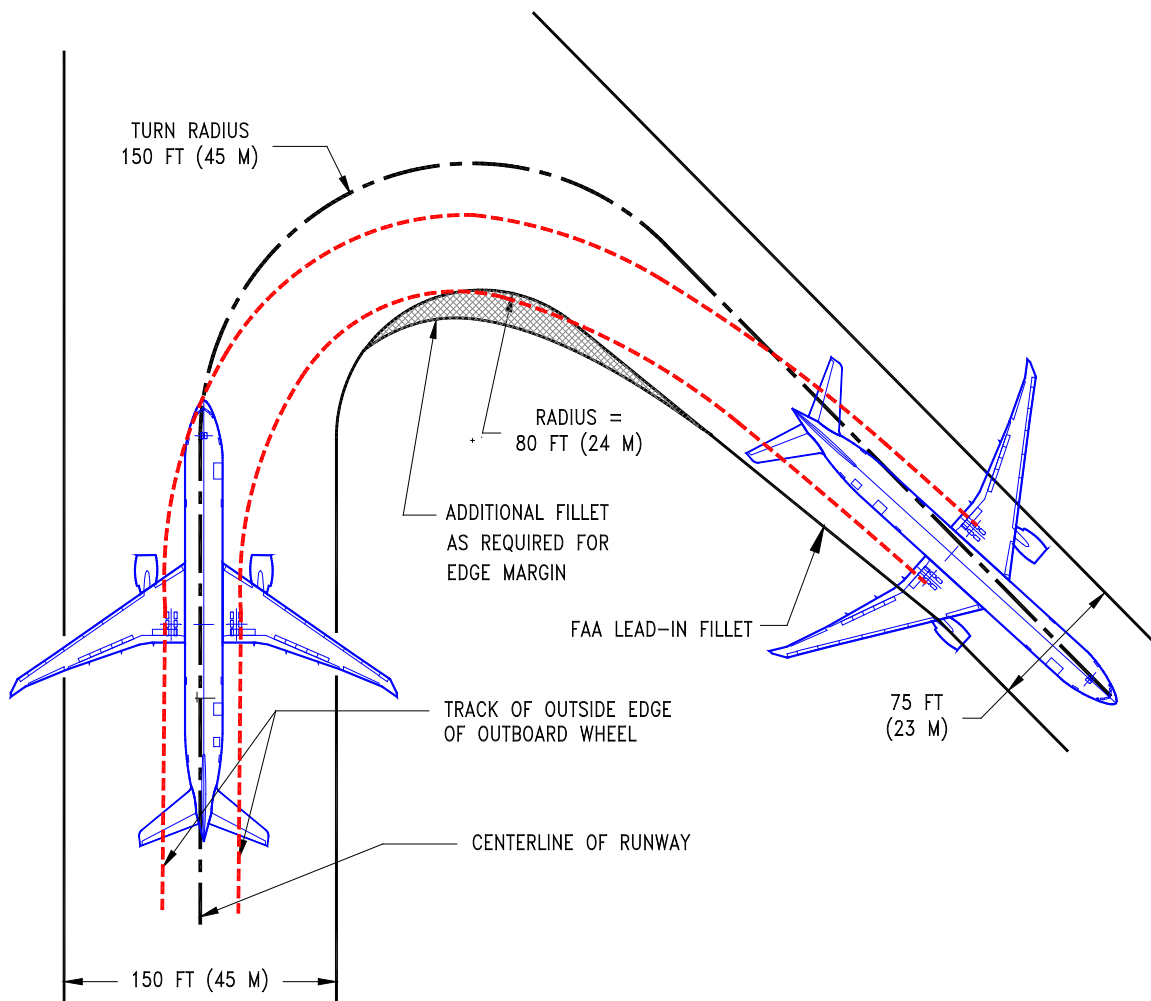

#### 4.5.2 Runway and Taxiway Turn Paths - Runway-to-Taxiway, 90 Degrees: Model 777-200LR, -300ER, 777F

##### NOTES:

- BEFORE DETERMINING THE SIZE OF THE INTERSECTION FILLET, CHECK WITH THE AIRLINES REGARDING THE OPERATING PROCEDURES THAT THEY USE AND THE AIRCRAFT TYPES THEY ARE EXPECTED TO USE AT THE AIRPORT
- 777-300ER DATA SHOWN. CALCULATED EDGE MARGIN FOR THE 777F IS APPROXIMATELY 20 FT (6.1 M) INSTEAD OF 14 FT (4.3 M) AS SHOWN.

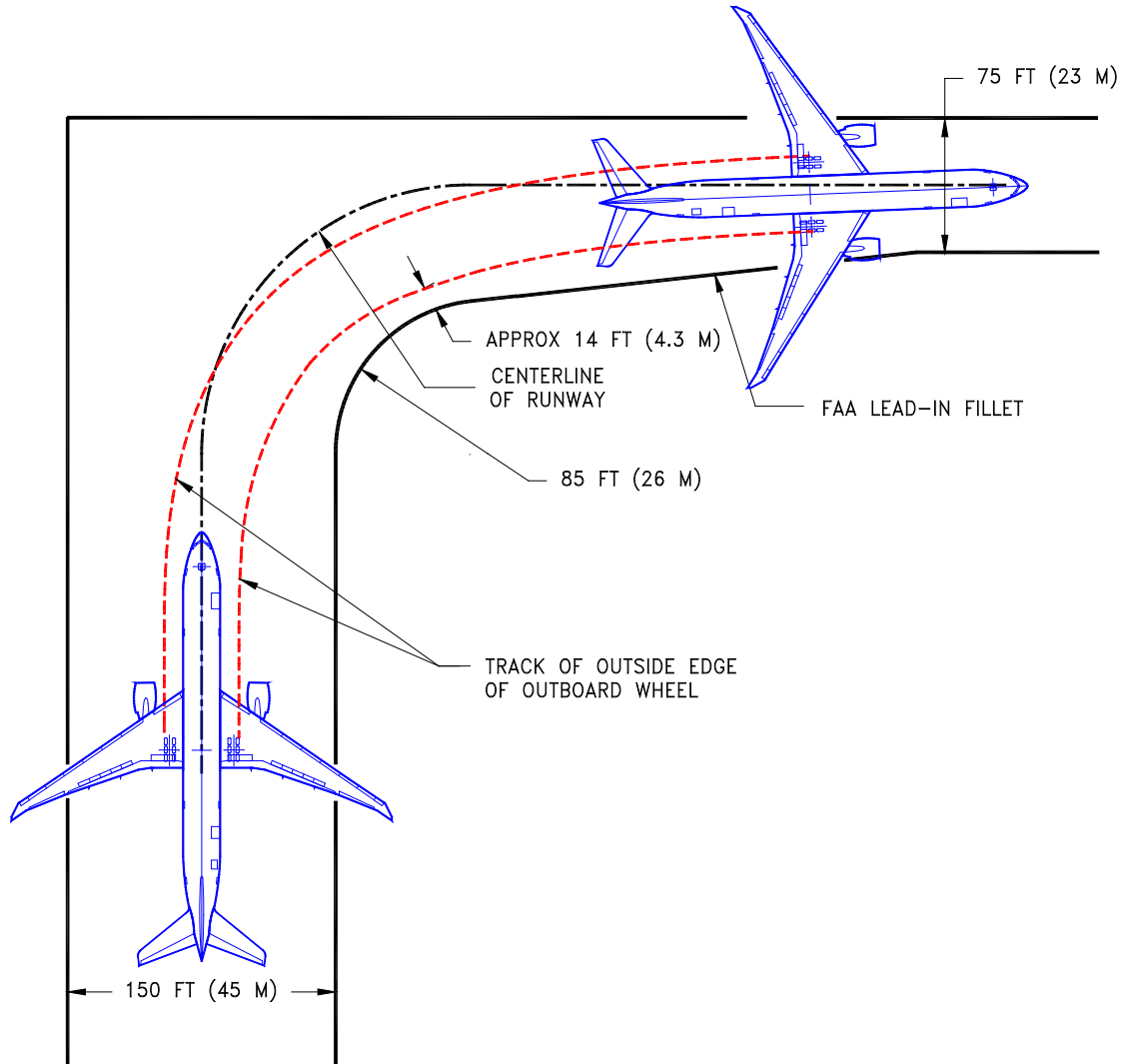

#### 4.5.3 Runway and Taxiway Turn Paths - Taxiway-to-Taxiway, 90 Degrees, Nose Gear Tracks Centerline: Model 777-200LR, -300ER, 777F

##### NOTES:

- BEFORE DETERMINING THE SIZE OF THE INTERSECTION FILLET, CHECK WITH THE AIRLINES REGARDING THE OPERATING PROCEDURES THAT THEY USE AND THE AIRCRAFT TYPES THEY ARE EXPECTED TO USE AT THE AIRPORT
- 777-300ER DATA SHOWN. CALCULATED EDGE MARGIN FOR THE 777F IS APPROXIMATELY 22 FT (6.7 M) INSTEAD OF 14 FT (4.3 M) AS SHOWN.

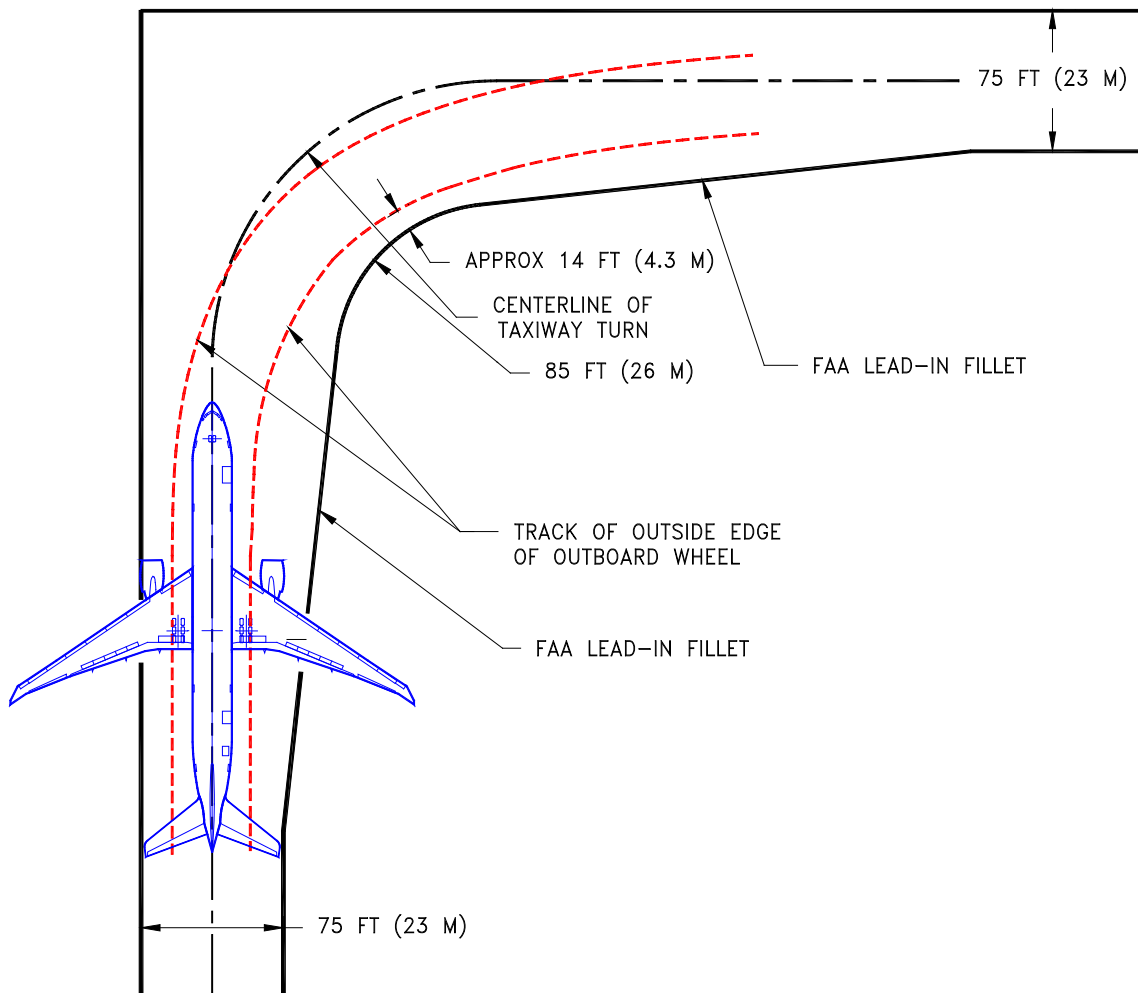



---

#### 4.5.4 Runway and Taxiway Turn Paths - Taxiway-to-Taxiway, 90 Degrees, Cockpit Tracks Centerline: Model 777-200LR, -300ER, 777F

**NOTES:**

- BEFORE DETERMINING THE SIZE OF THE INTERSECTION FILLET, CHECK WITH THE AIRLINES REGARDING THE OPERATING PROCEDURES THAT THEY USE AND THE AIRCRAFT TYPES THEY ARE EXPECTED TO USE AT THE AIRPORT
- 777-300ER DATA SHOWN. CALCULATED EDGE MARGIN FOR THE 777F IS APPROXIMATELY 17 FT (5.2 M) INSTEAD OF 4 FT (1.2 M) AS SHOWN.

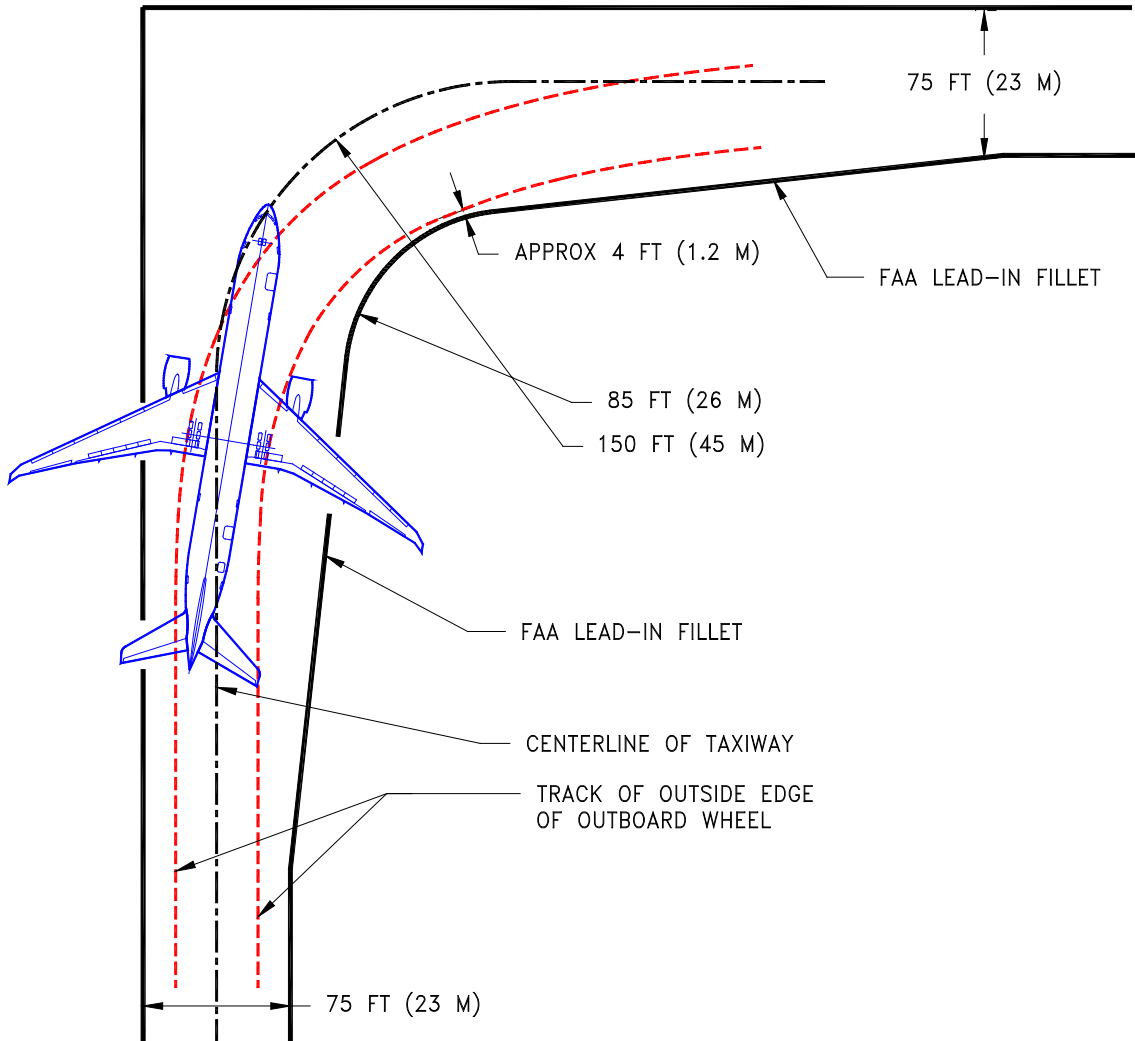

#### 4.5.5 Runway and Taxiway Turn Paths - Taxiway-to-Taxiway, 90 Degrees, Judgmental Oversteering: Model 777-200LR, -300ER, 777F

**NOTES:**

- BEFORE DETERMINING THE SIZE OF THE INTERSECTION FILLET, CHECK WITH THE AIRLINES REGARDING THE OPERATING PROCEDURES THAT THEY USE AND THE AIRCRAFT TYPES THEY ARE EXPECTED TO USE AT THE AIRPORT
- 777-300ER DATA SHOWN. 777F IS LESS STRINGENT

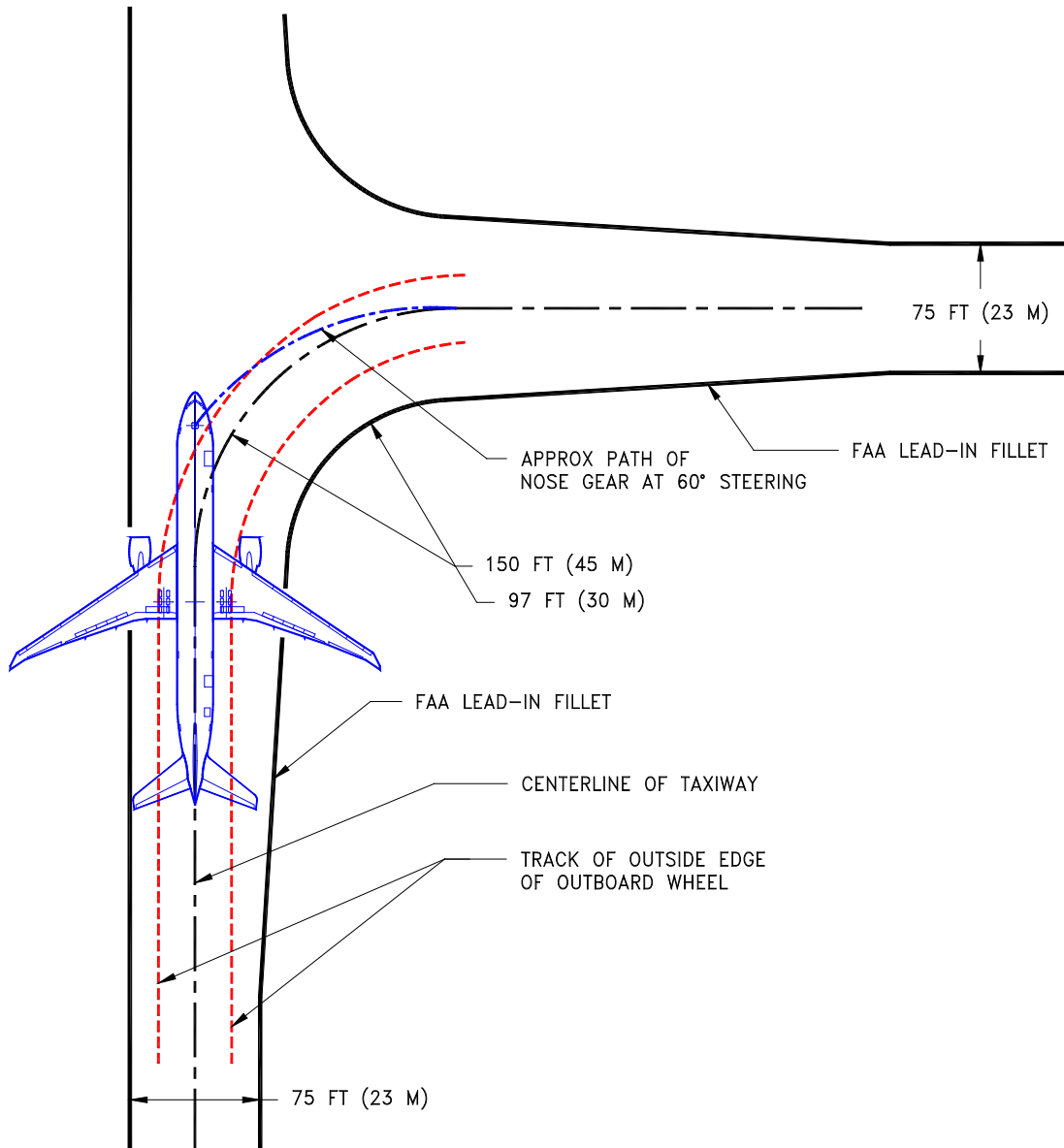

#### 4.6 RUNWAY HOLDING BAY: MODEL 777-200LR, -300ER, 777F

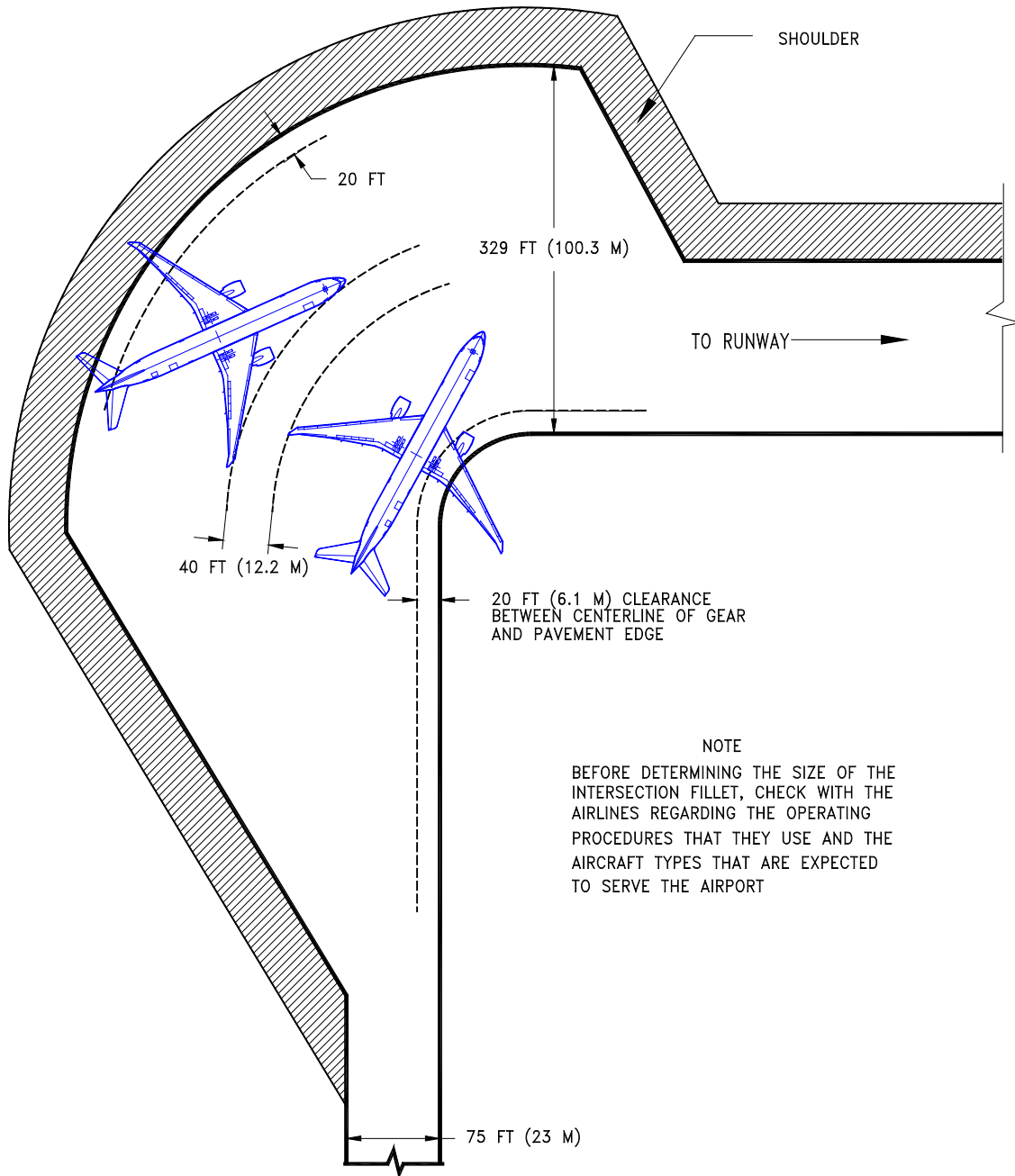

D6-58329-2

REV F

December 2022

4-12

---

## 5.0 TERMINAL SERVICING

During turnaround at the terminal, certain services must be performed on the aircraft, usually within a given time, to meet flight schedules. This section shows service vehicle arrangements, schedules, locations of service points, and typical service requirements. The data presented in this section reflect ideal conditions for a single airplane. Service requirements may vary according to airplane condition and airline procedure.

Section 5.1 shows typical arrangements of ground support equipment during turnaround. As noted, if the auxiliary power unit (APU) is used, the electrical, air start, and air-conditioning service vehicles would not be required. Passenger loading bridges or portable passenger stairs could be used to load or unload passengers.

Sections 5.2 and 5.3 show typical service times at the terminal. These charts give typical schedules for performing service on the airplane within a given time. Service times could be rearranged to suit availability of personnel, airplane configuration, and degree of service required.

Section 5.4 shows the locations of ground service connections in graphic and in tabular forms. Typical capacities and service requirements are shown in the tables. Services with requirements that vary with conditions are described in subsequent sections.

Section 5.5 shows typical sea level air pressure and flow requirements for starting different engines. The curves are based on an engine start time of 90 seconds.

Section 5.6 shows air conditioning requirements for heating and cooling (pull-down and pull-up) using ground conditioned air. The curves show airflow requirements to heat or cool the airplane within a given time at ambient conditions.

Section 5.7 shows air conditioning requirements for heating and cooling to maintain a constant cabin air temperature using low pressure conditioned air. This conditioned air is supplied through an 8-in ground air connection (GAC) directly to the passenger cabin, bypassing the air cycle machines.

Section 5.8 shows ground towing requirements for various ground surface conditions.

## 5.1 AIRPLANE SERVICING ARRANGEMENT - TYPICAL TURNAROUND

### 5.1.1 Airplane Servicing Arrangement - Typical Turnaround: Model 777-200 / -200ER / -200LR

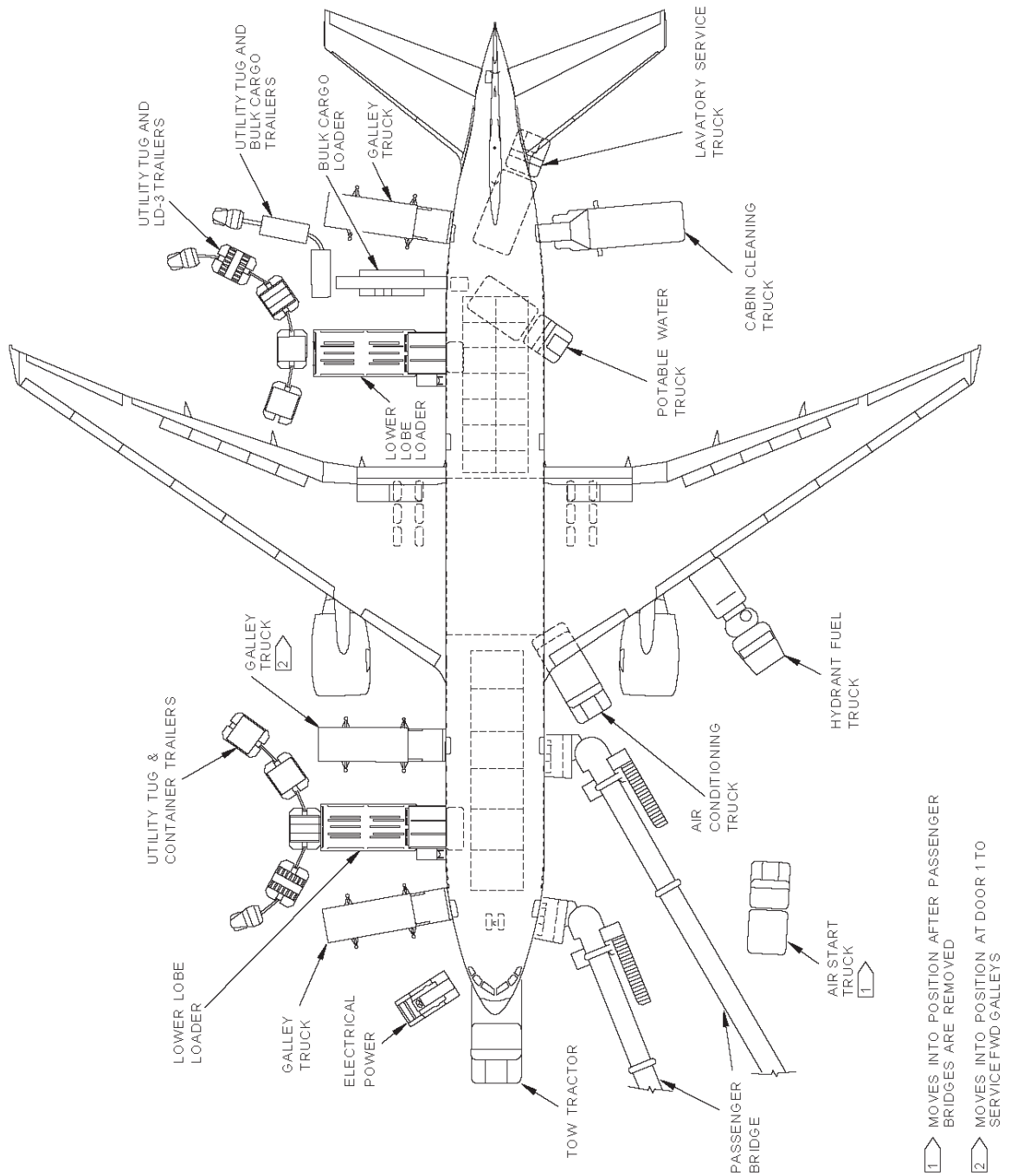

D6-58329-2

REV F

December 2022

5-2

## 5.1.2 Airplane Servicing Arrangement - Typical Turnaround: Model 777-300 / -300ER

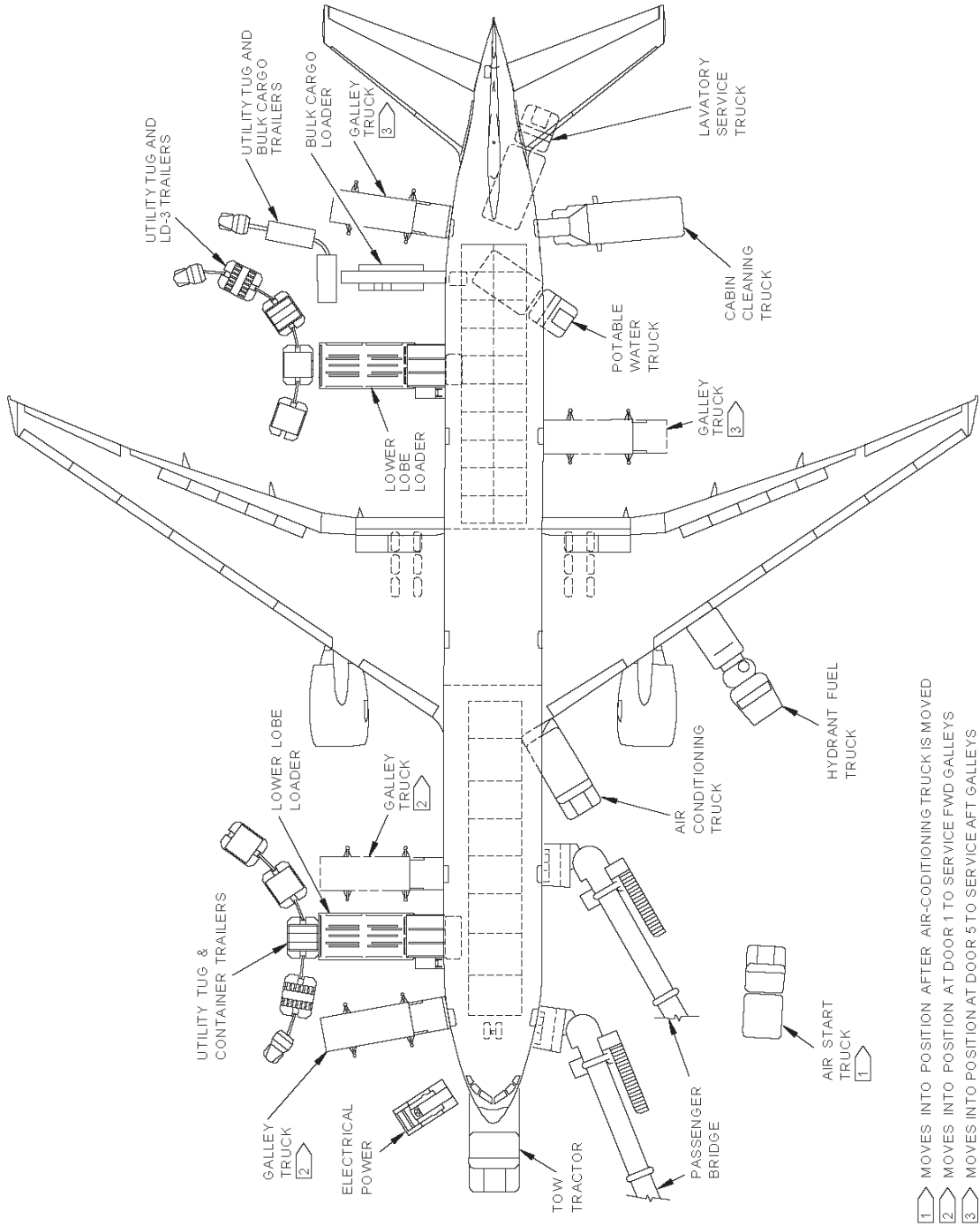

---

### 5.1.3 Airplane Servicing Arrangement - Typical Turnaround: Model 777F

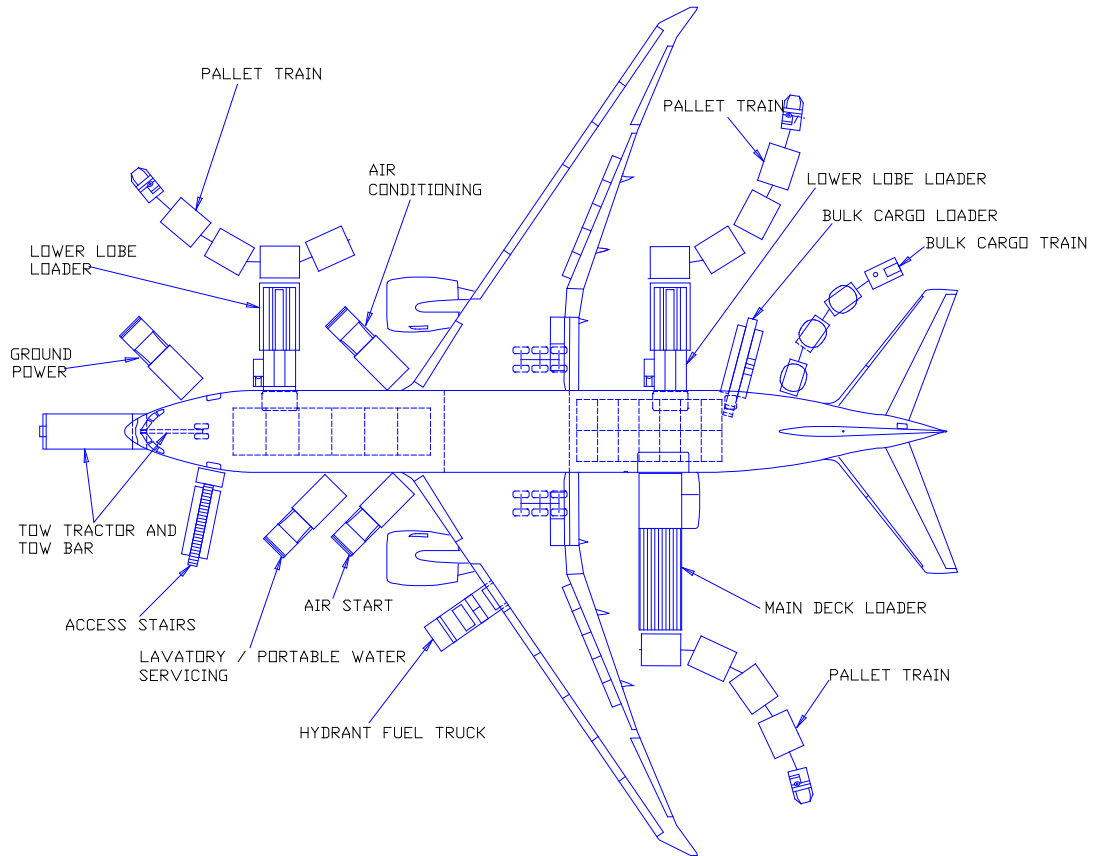

## 5.2 TERMINAL OPERATIONS - TURNAROUND STATION

### 5.2.1 Terminal Operations - Turnaround Station: Model 777-200LR

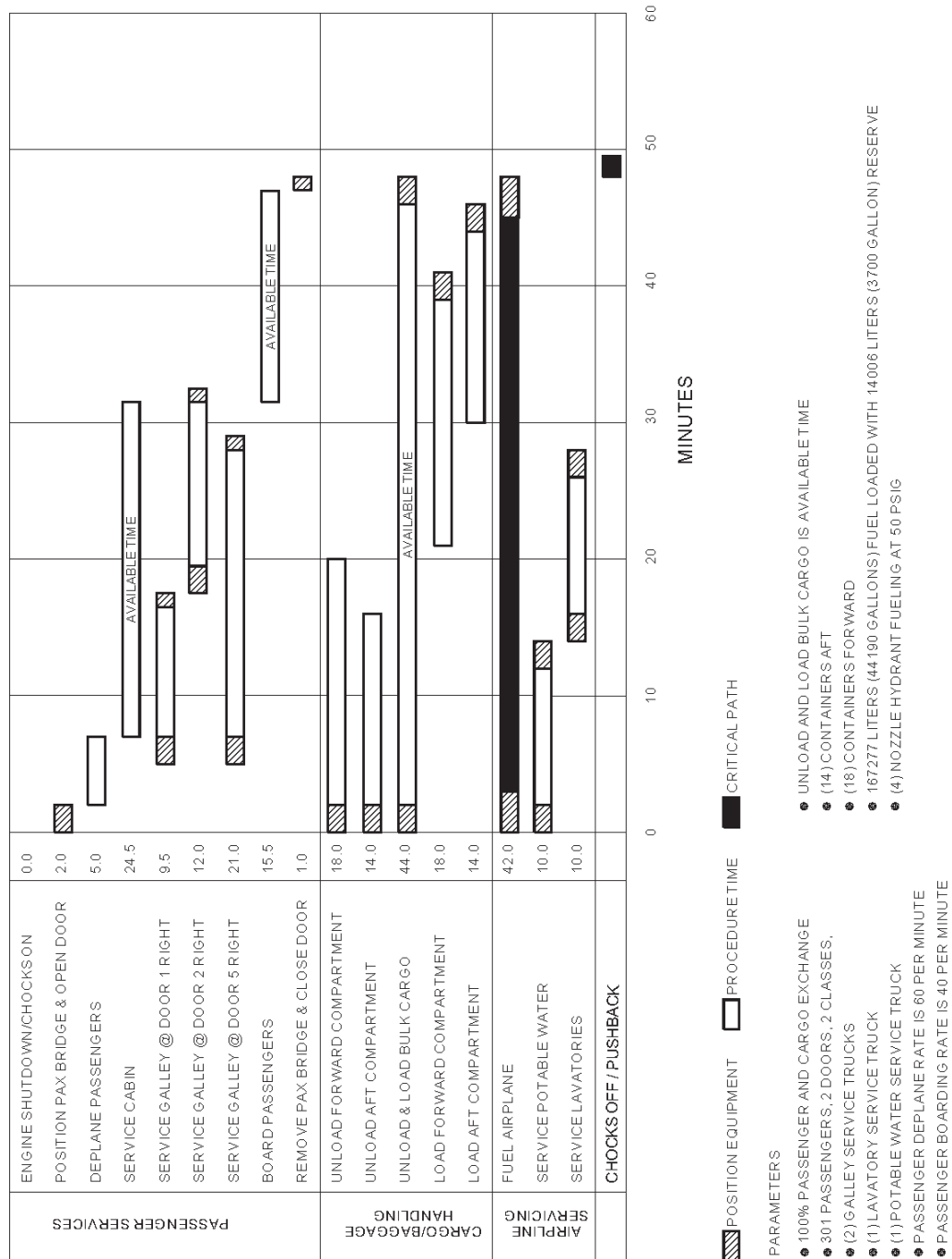



## 5.2.2 Terminal Operations - Turnaround Station: Model 777-300ER

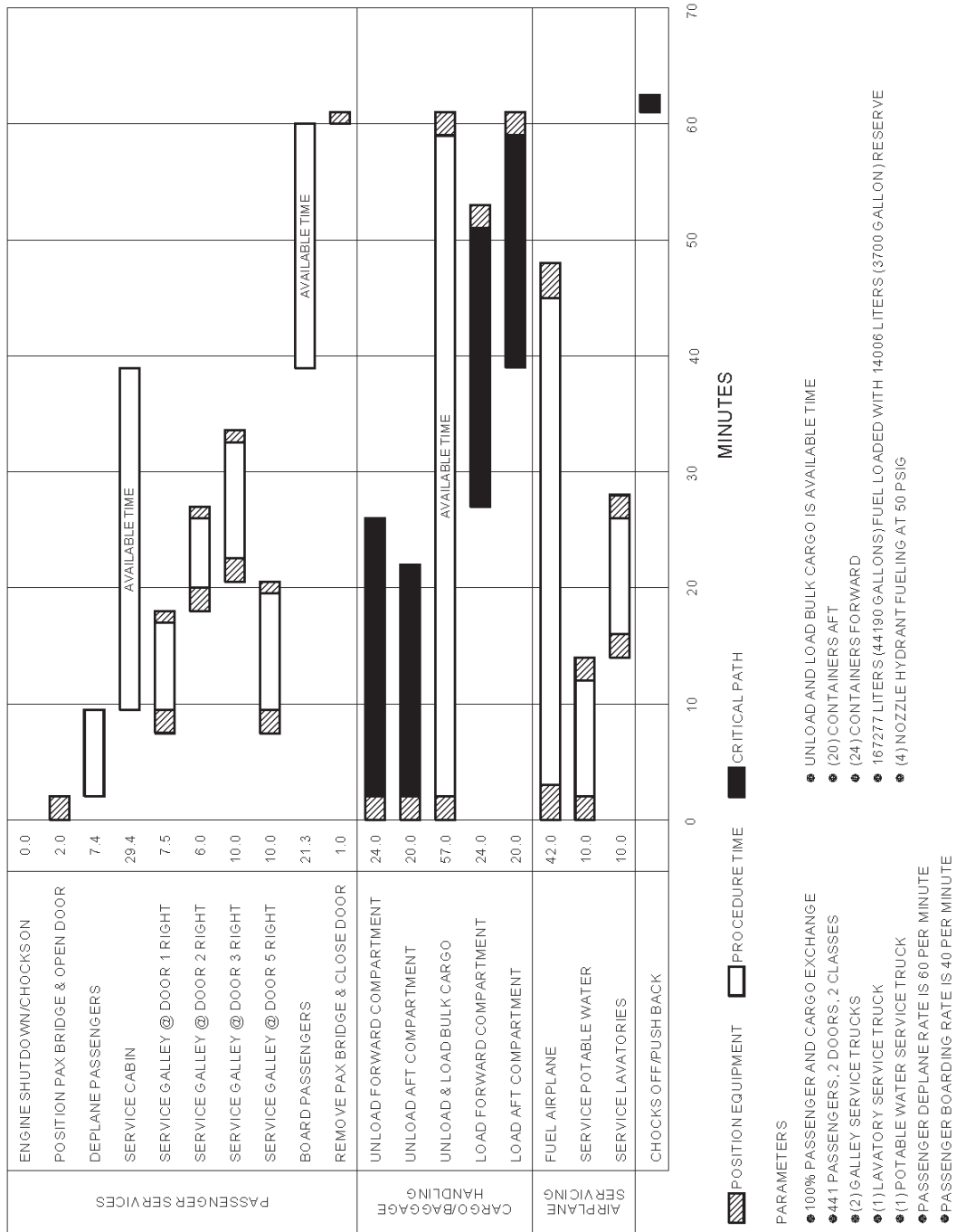

NOTE: IMPROVED FUELING CAPABILITY APPLIES TO AIRPLANE LINE NUMBER 991 AND ON OR TO PRIOR AIRPLANES WITH SERVICE BULLETIN MODIFICATIONS INCORPORATED. WITHOUT SERVICE BULLETIN INCORPORATION, THE PROJECTED FUELING TIME OF THE 777-300ER INCREASES TO 68 MINUTES AND BECOMES THE CRITICAL PATH FOR AIRPLANE TURN AROUND. THE OVERALL PROJECTED TURN TIME INCREASES TO 64 MINUTES.

### 5.2.3 Terminal Operations - Turnaround Station: Model 777F

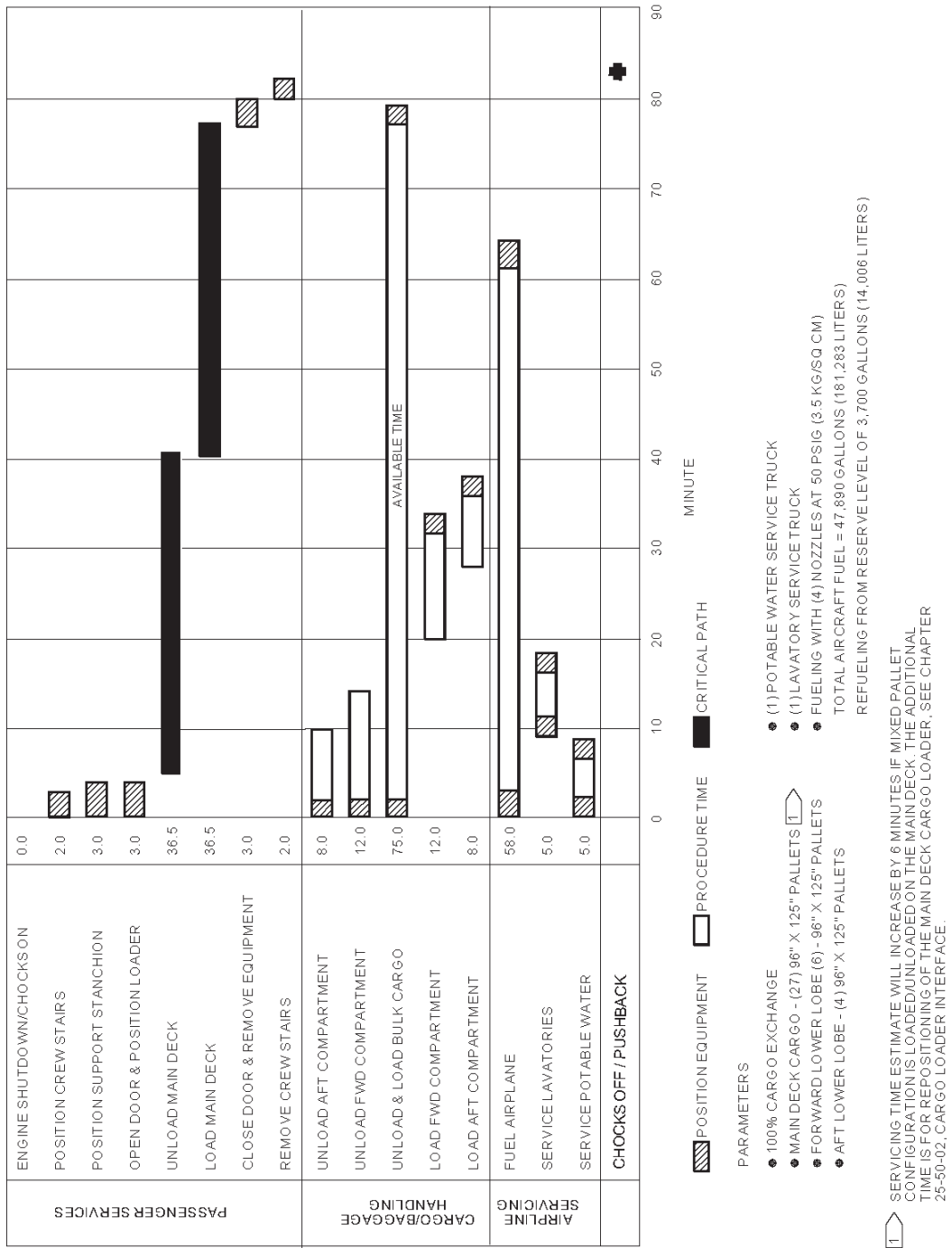

### 5.3 TERMINAL OPERATIONS - EN ROUTE STATION

#### 5.3.1 Terminal Operations - En Route Station: Model 777-200 / -200ER / -200LR

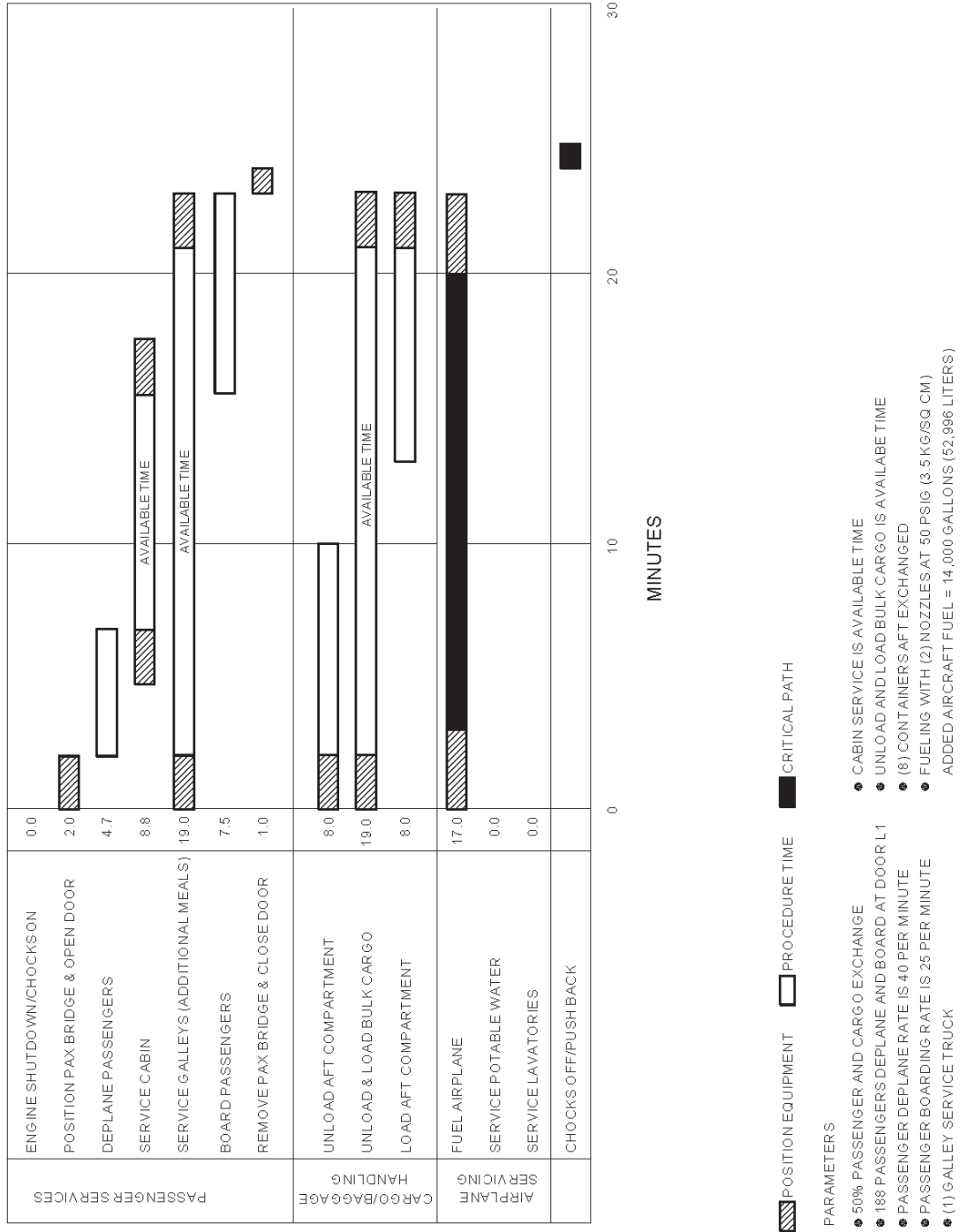

### 5.3.2 Terminal Operations - En Route Station: Model 777-300 / -300ER

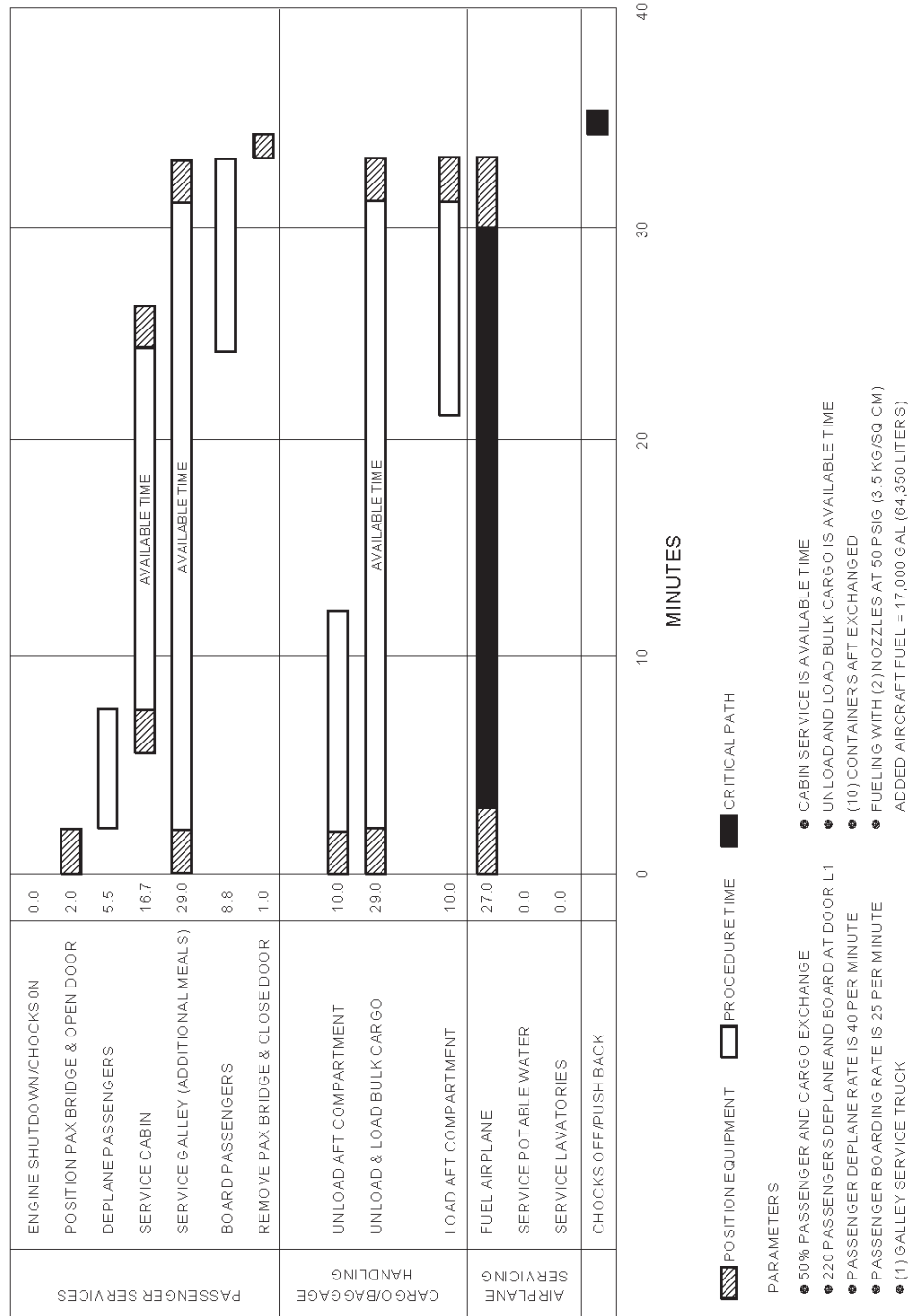

## 5.4 GROUND SERVICING CONNECTIONS

### 5.4.1 Ground Service Connections: Model 777-200LR

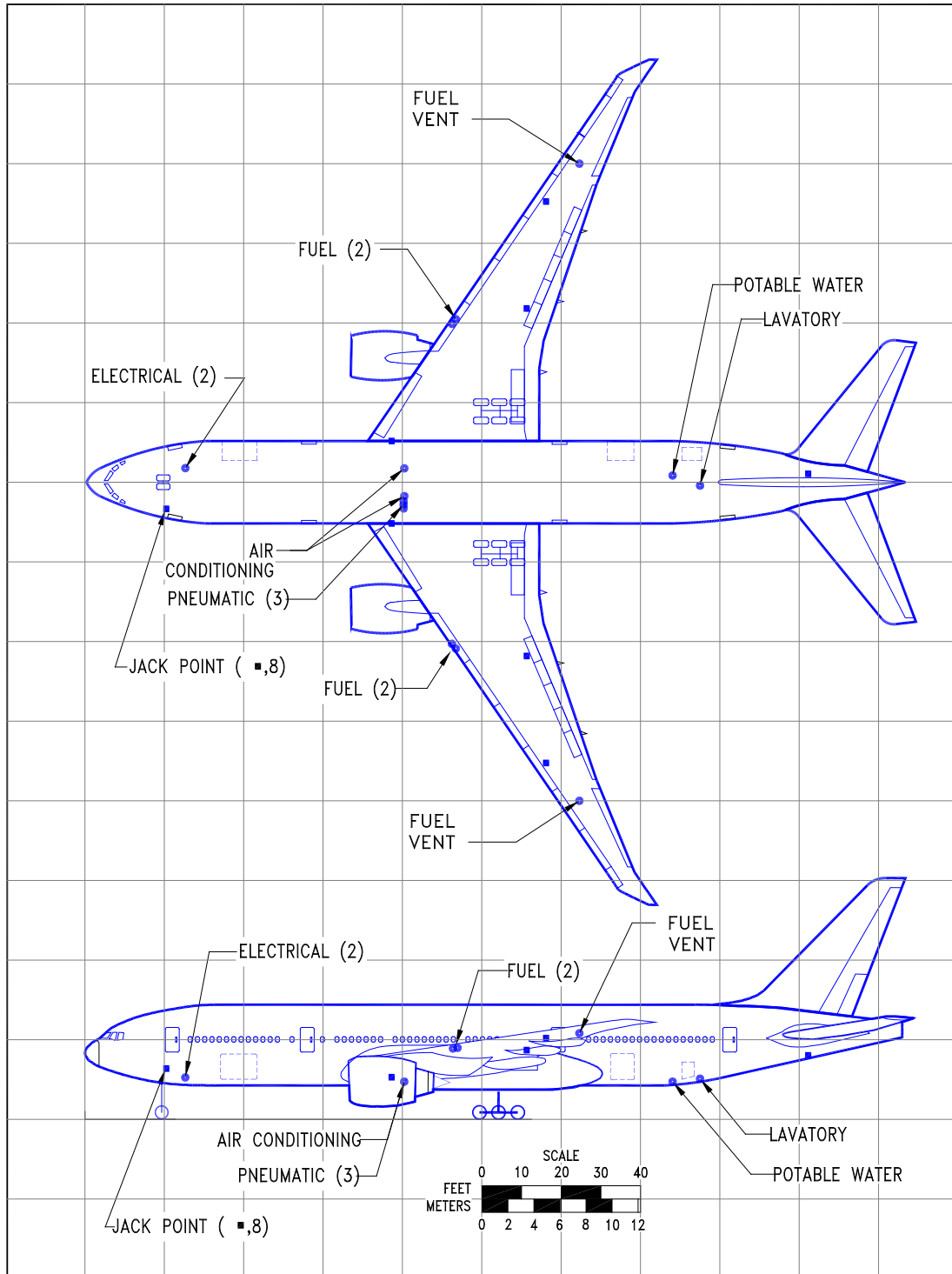

D6-58329-2

REV F

December 2022

5-10

Not Subject to EAR or ITAR.  
Copyright © 2023 Boeing. All Rights Reserved.

## 5.4.2 Ground Service Connections: Model 777-300ER

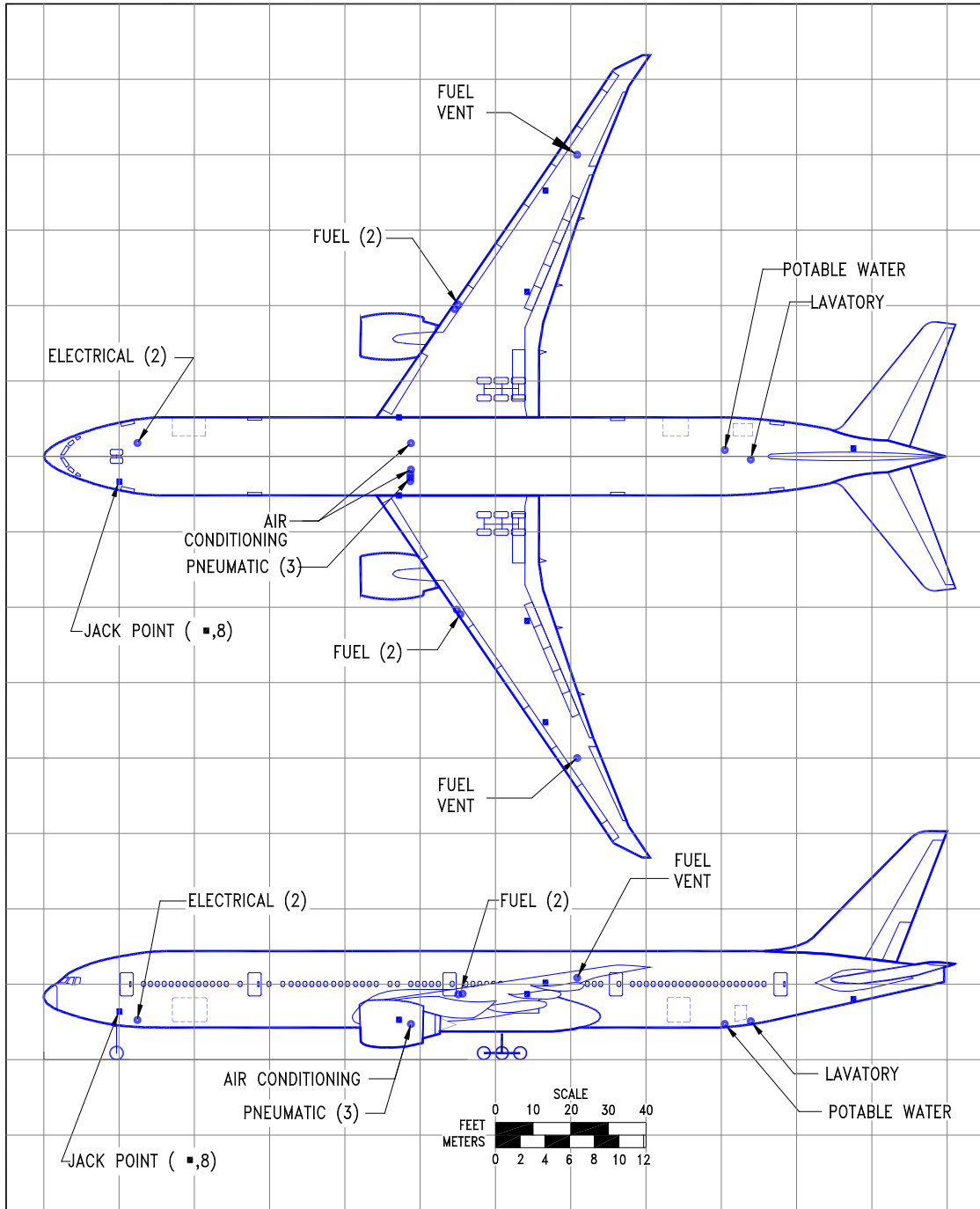

D6-58329-2

REV F

December 2022

5-11

Not Subject to EAR or ITAR.  
Copyright © 2023 Boeing. All Rights Reserved.

### 5.4.3 Ground Service Connections: Model 777F

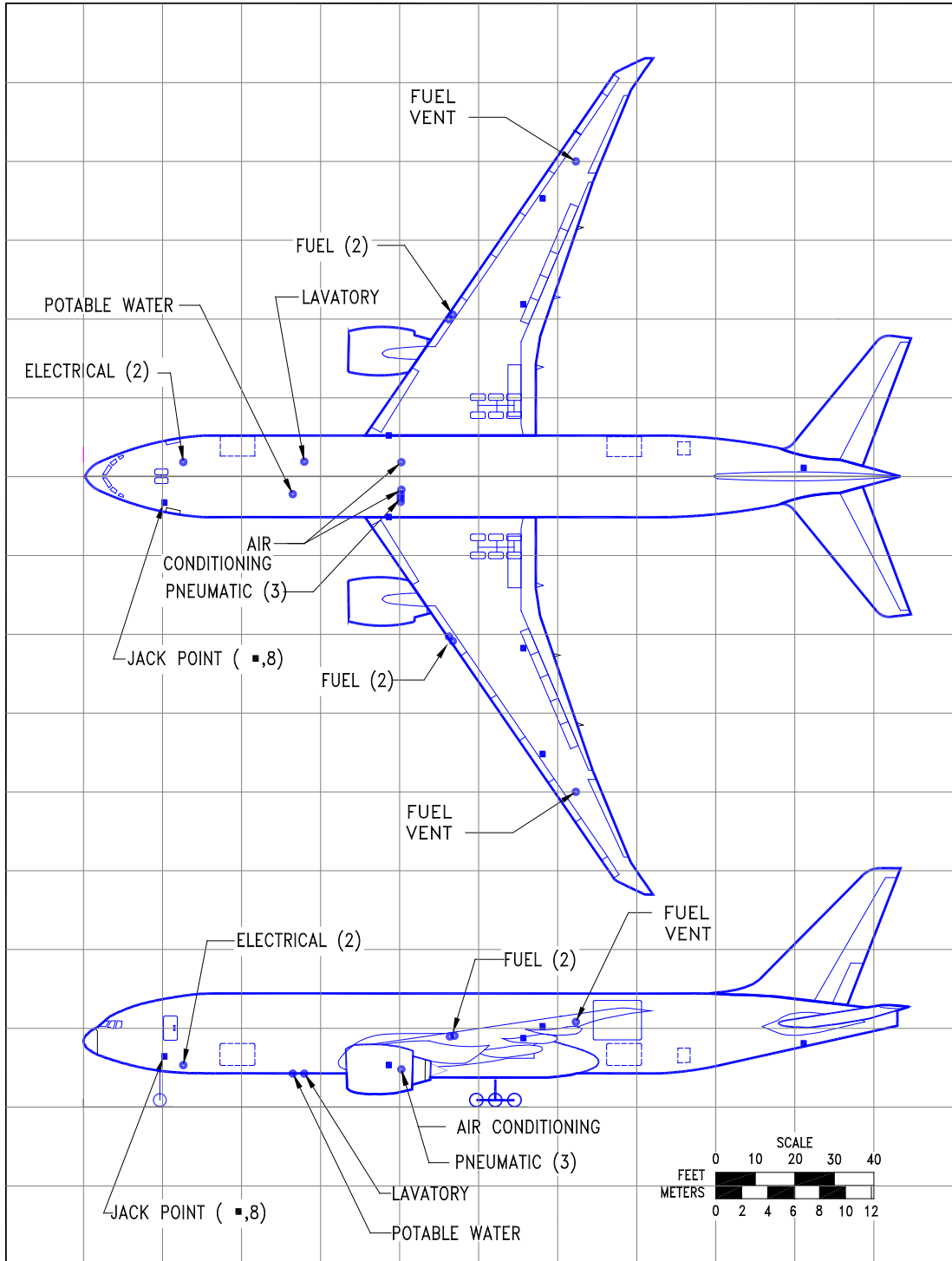

D6-58329-2

#### 5.4.4 Ground Service Connections and Capacities: Model 777-200LR, -300ER, 777F

SYSTEM	MODEL	DISTANCE AFT OF		DISTANCE FROM AIRPLANE CENTERLINE				MAX HEIGHT ABOVE	
		NOSE		LH SIDE		RH SIDE		GROUND	
		FT-IN	M	FT-IN	M	FT-IN	M	FT-IN	M
CONDITIONED AIR TWO 8-IN (20.3 CM) PORTS	777-200LR	80	24.4	3	0.9	3	0.9	8	2.4
	777-FREIGHTER	80	24.4	3	0.9	3	0.9	8	2.4
	777-300ER	97	29.6	3	0.9	3-6	1.1	9	2.7
ELECTRICAL  TWO CONNECTIONS - -90 KVA , 200/115 V AC 400 HZ, 3-PHASE EACH	777-200LR	23	7.0	-	-	4	1.2	9	2.7
	777-FREIGHTER	23	7.1	-	-	4	1.2	10	3.0
	777-300ER	23	7.0	-	-	3-6	1.1	9	3.0
FUEL  TWO UNDERWING PRESSURE CONNECTORS ON EACH WING  FUEL VENTS – WING TANK CAPACITIES STANDARD = 47,890 GAL (181, 260 L) THREE OPTIONAL BODY TANKS = 5,550 GAL (21,000 L)	777-200LR	92	28.0	39	11.9	39	11.9	19	5.8
	777 FREIGHTER	94	28.7	41	12.5	41	12.5	18	5.5
	777-300ER	110	33.8	39	11.9	39	11.9	18	5.5
		111	33.8	41	12.5	41	12.5	18	5.5
	777-200LR	125	38.1	80	24.4	80	24.4	22	6.7
	777 FREIGHTER	123	37.5	80	24.4	80	24.4	22	6.7
LAVATORY  ONE SERVICE CONNECTION	777-200LR	56	17.1	1	0.3	-	-	11	3.4
	777 FREIGHTER	56	17.1			4	1.1	10	2.9
	777-300ER	181	55.2	1	0.3	-	-	11	3.4
PNEUMATIC  THREE 3-IN (7.6-CM) PORTS  AIR START	777-200LR	80	24.4	5	1.5	-	-	8	2.4
	777 FREIGHTER	80	24.4	6	1.8	-	-	8	2.4
		80	24.4	7	2.1	-	-	8	2.4
	777-300ER	97	29.6	5	1.5	-	-	8	2.4
		97	29.6	6	1.8	-	-	8	2.4
		97	29.6	7	2.1	-	-	8	2.4
POTABLE WATER  ONE SERVICE CONNECTION  AFT LOCATION (BASIC)  FWD LOCATION (OPTIONAL)	777 FREIGHTER	53	16.2	5	1.5			10	3.0
	777-200LR	147	44.8	-	-	3	0.9	10	3.0
	777-300ER	181	55.2	-	-	3	0.9	10	3.0
	777-200LR	29	8.8	4	1.2	-	-	9	2.7
	777-300ER	29	8.8	4	1.2	-	-	9	2.7

**NOTE:** DISTANCES ROUNDED TO THE NEAREST FOOT AND 0.1 METER.



## 5.5 ENGINE STARTING PNEUMATIC REQUIREMENTS

### 5.5.1 Engine Start Pneumatic Requirements - Sea Level: Model 777-200LR, -300ER

NOTES:

1. ALTITUDE = SEA LEVEL
2. 90 SECONDS TO IDLE
3. 2 GROUND CONNECTIONS USED

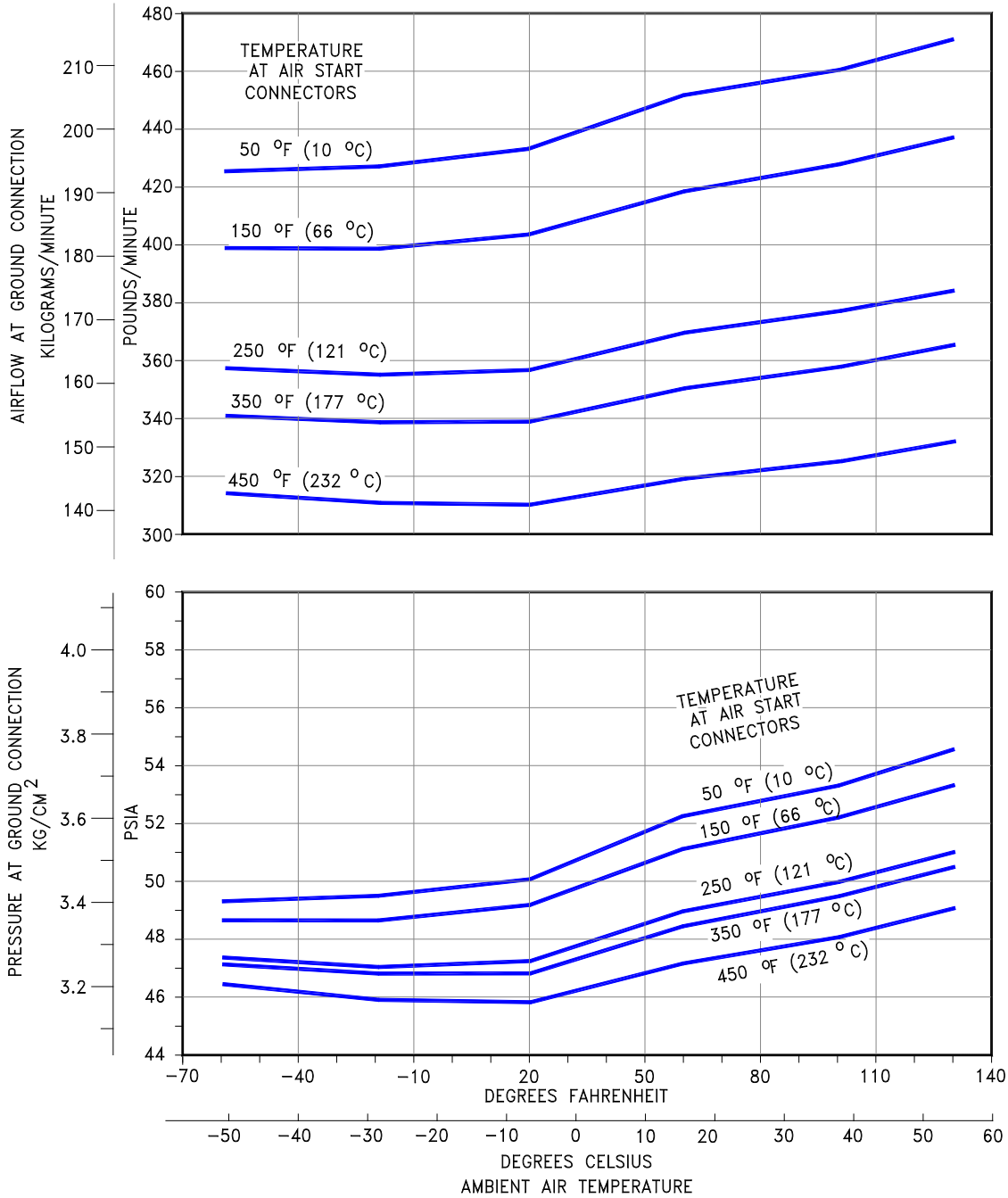

## 5.6 GROUND PNEUMATIC POWER REQUIREMENTS

### 5.6.1 Ground Pneumatic Power Requirements – Heating, Pull-Up: Model 777-200LR

**CONDITIONS:**

ALL EXTERIOR DOORS AND WINDOWS CLOSED  
 OUTSIDE TEMPERATURE -40°F (-40°C)  
 INITIAL CABIN TEMPERATURE -25°F (-32°C)  
 NO SOLAR HEAT LOAD

RECIRCULATION FANS OFF  
 CHILLERS OFF  
 MINIMUM LIGHTING  
 NO OCCUPANTS

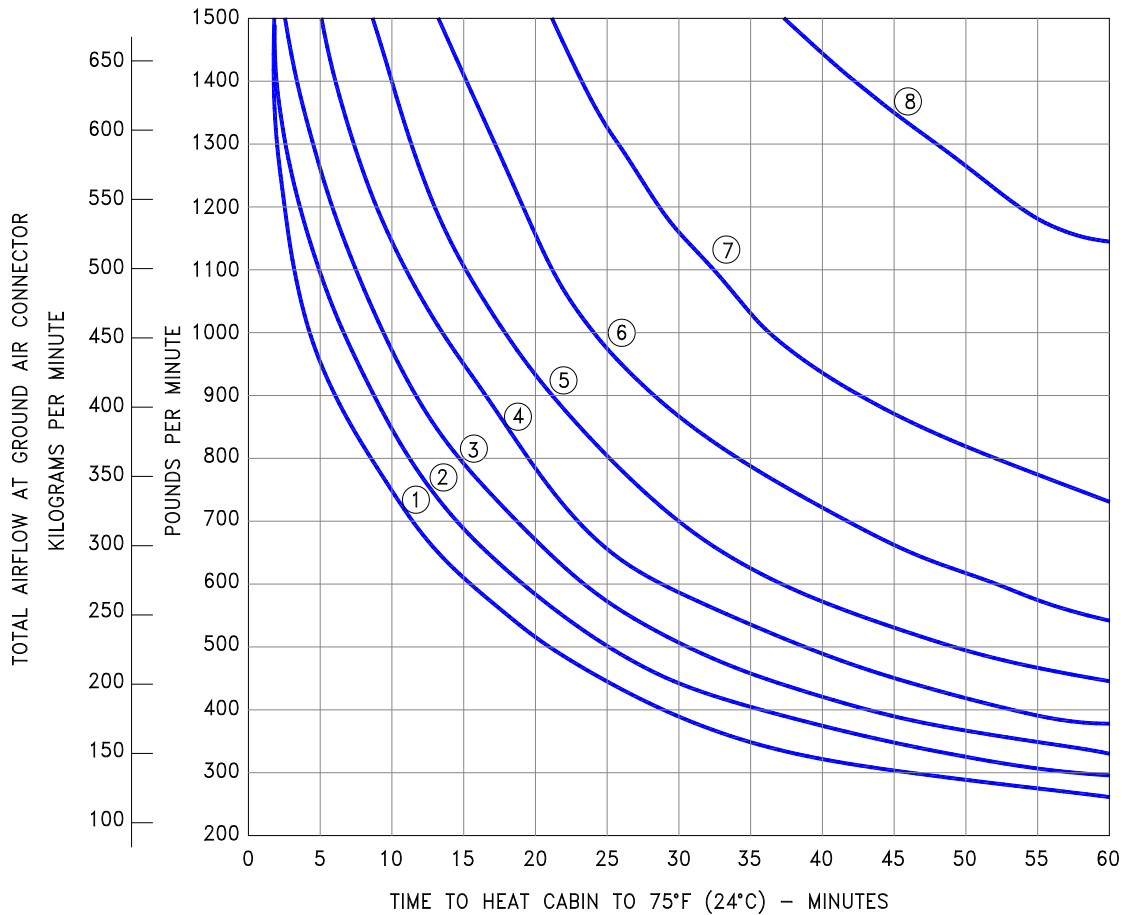

**AIR TEMPERATURE AT GROUND AIR CONNECTION**

- |                |                |
|----------------|----------------|
| ① 160°F (71°C) | ⑤ 120°F (49°C) |
| ② 150°F (66°C) | ⑥ 110°F (43°C) |
| ③ 140°F (60°C) | ⑦ 100°F (38°C) |
| ④ 130°F (54°C) | ⑧ 90°F (32°C)  |

NOTE: THIS GRAPH SHOWS THE TIME REQUIRED TO HEAT THE CABIN TO 75°F (24°C) AS A FUNCTION OF AIRFLOW WHEN USING A CONDITIONED AIR GROUND SOURCE

## 5.6.2 Ground Pneumatic Power Requirements – Cooling, Pull-Down: Model 777-200LR

**CONDITIONS:**

ALL EXTERIOR DOORS AND WINDOWS CLOSED  
 OUTSIDE TEMPERATURE 103°F (39°C)  
 INITIAL CABIN TEMPERATURE 115°F (46°C)  
 FULL SOLAR LOAD

RECIRCULATION FANS OFF  
 CHILLERS ON  
 MINIMUM LIGHTING  
 NO OCCUPANTS

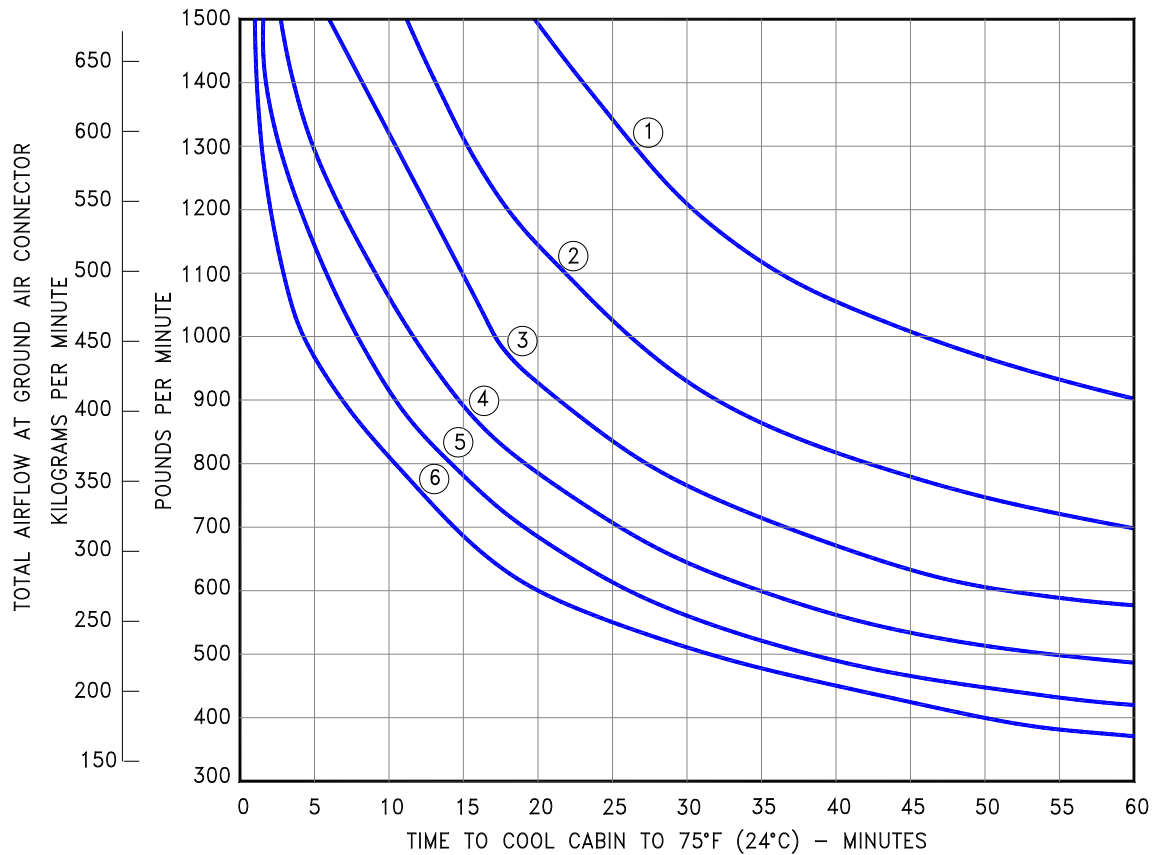

**AIR TEMPERATURE AT GROUND CONNECTION**

- |               |              |
|---------------|--------------|
| ① 60°F (16°C) | ④ 45°F (7°C) |
| ② 55°F (13°C) | ⑤ 40°F (4°C) |
| ③ 50°F (10°C) | ⑥ 35°F (2°C) |

NOTE: THIS GRAPH SHOWS THE TIME REQUIRED TO COOL THE CABIN TO 75°F (24°C)  
 AS A FUNCTION OF AIRFLOW WHEN USING A CONDITIONED AIR GROUND SOURCE.

### 5.6.3 Ground Conditioned Air Requirements – Heating, Pull-Up: Model 777-300ER

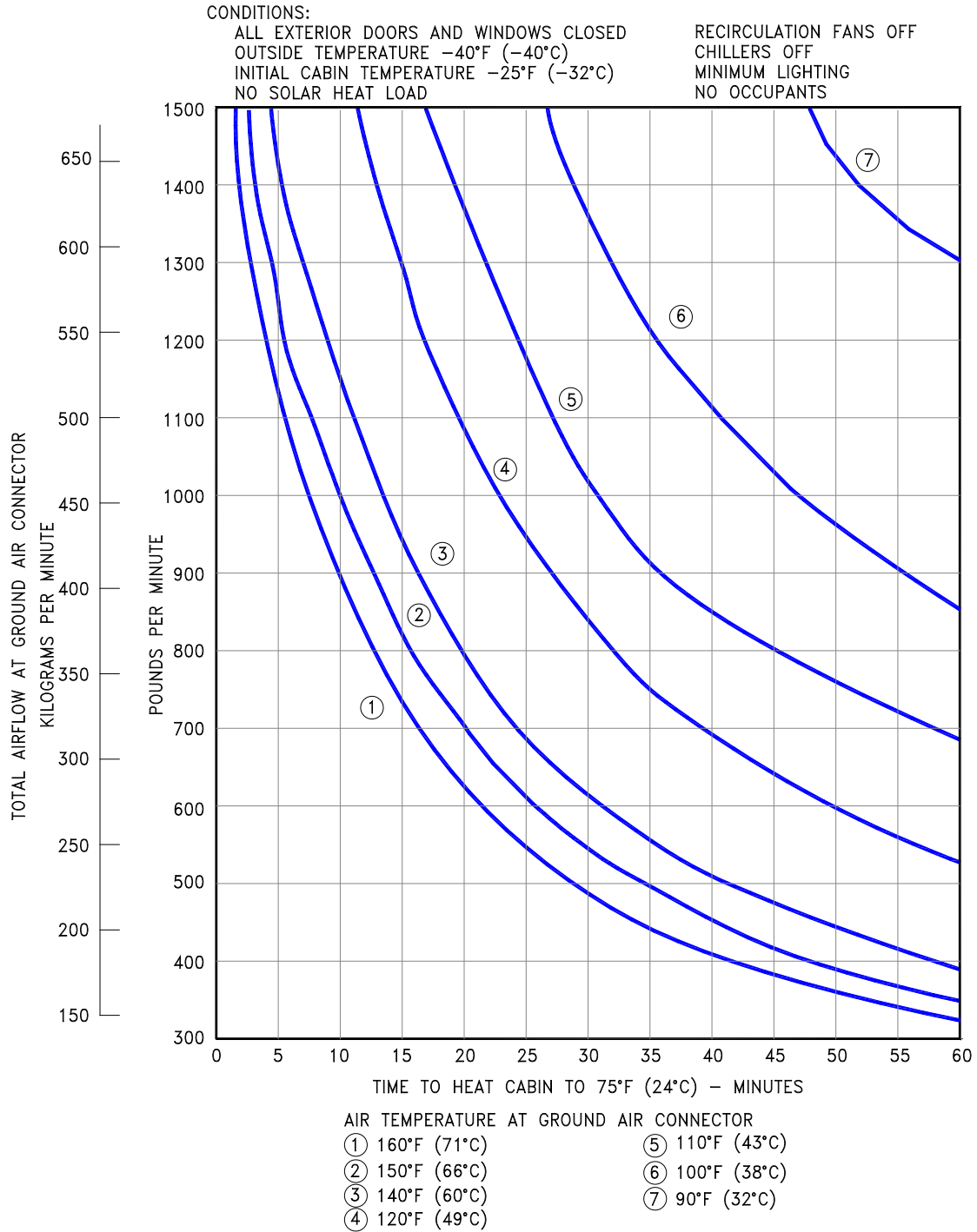

NOTE: THIS GRAPH SHOWS THE TIME REQUIRED TO HEAT THE CABIN TO 75°C (24°C) AS A FUNCTION OF AIRFLOW WHEN USING A CONDITIONED AIR GROUND SOURCE

## 5.6.4 Ground Conditioned Air Requirements – Cooling, Pull-Down: Model 777-300ER

**CONDITIONS:**

ALL EXTERIOR DOORS AND WINDOWS CLOSED  
 OUTSIDE TEMPERATURE 103°F (39°C)  
 INITIAL CABIN TEMPERATURE 115°F (46°C)  
 FULL SOLAR LOAD

RECIRCULATION FANS OFF  
 CHILLERS ON  
 MINIMUM LIGHTING  
 NO OCCUPANTS

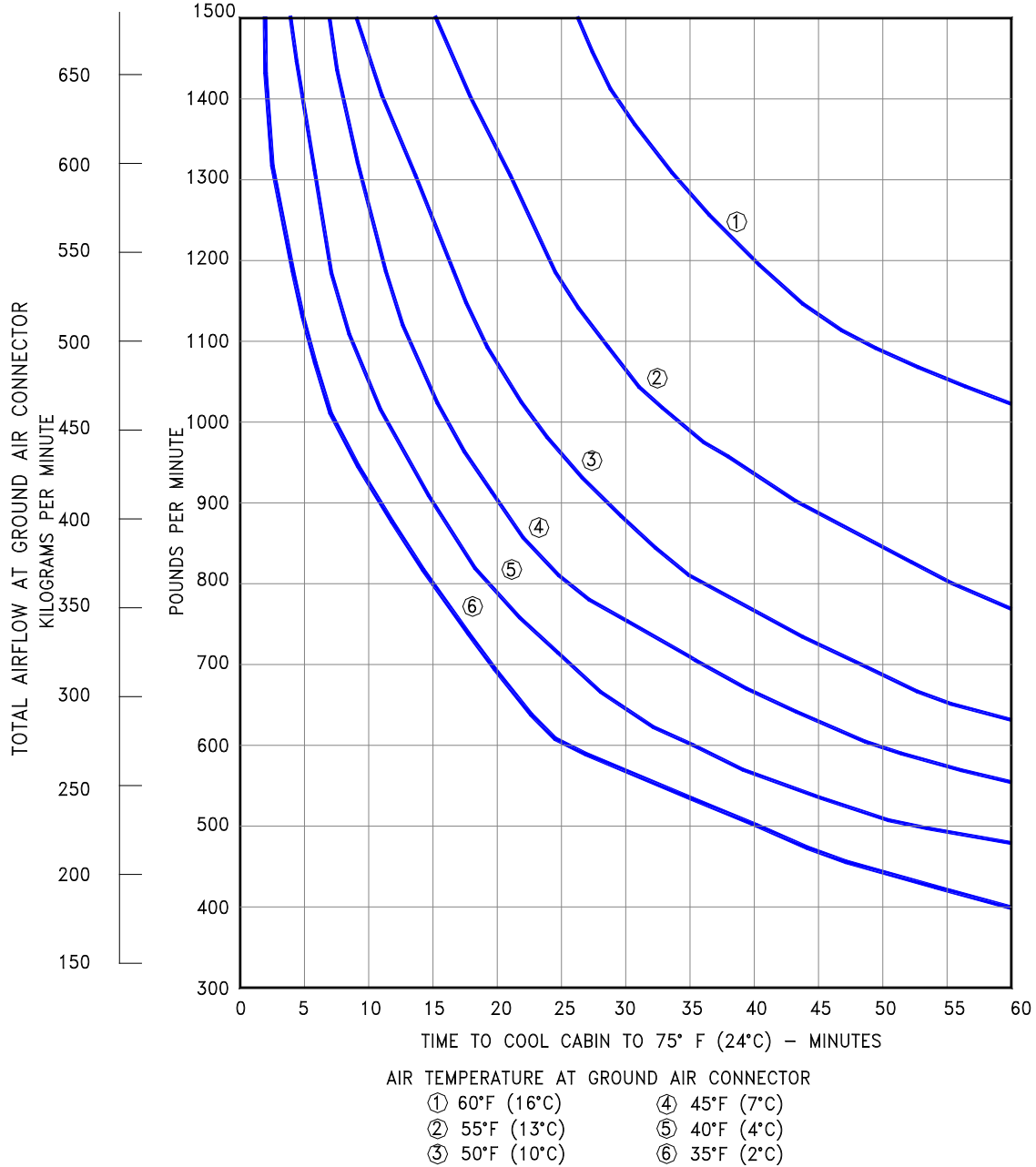

NOTE: THIS GRAPH SHOWS THE TIME REQUIRED TO COOL THE CABIN TO 75°F (24°C) AS A FUNCTION OF AIRFLOW WHEN USING A CONDITIONED AIR GROUND SOURCE.

D6-58329-2

REV F

December 2022

5-18

## 5.6.5 Ground Conditioned Air Requirements – Heating, Pull-Up: Model 777F

### CONDITIONS:

- ALL EXTERIOR DOORS AND WINDOWS CLOSED
- OUTSIDE TEMPERATURE 103° F (39° C)
- MAIN DECK SOLAR LOAD: 0 BTU/MIN – MAIN DECK HAS FEW WINDOWS; SUPERNUMERARY AREA IS NEGLIGIBLE
- MAIN DECK ELECTRICAL LOAD: 75 BTU/MIN – MAXIMUM HEAT DISSIPATION FROM CARGO LIGHTING
- RECIRCULATION FANS OFF
- MAIN DECK (MD) CHILLER HEAT DISSIPATION: 0 BTU/MIN – NO MD CHILLER
- NO HEAT GENERATING CARGO
- INITIAL CABIN TEMPERATURE: 115° F (46° C)
- SKIN TEMPERATURE: 118° F (48° C)
- MAIN DECK FLOW SWITCH: SELECTED TO NORMAL
- FORWARD CARGO AIR CONDITIONING (FCAC): SELECTED "ON" WITH 14.6% OF TOTAL FLOW
- AFT CARGO AIR CONDITIONING (ACAC): ASSUMED "OFF" (CUSTOMER OPTION)
- MAIN DECK HEAT TRANSFER COEFFICIENT IS 27.2 BTU/MIN\*F WITH A 10% FLOOR HEAT TRANSFER FACTOR. DOES NOT INCLUDE THE RIGID CARGO BARRIER.

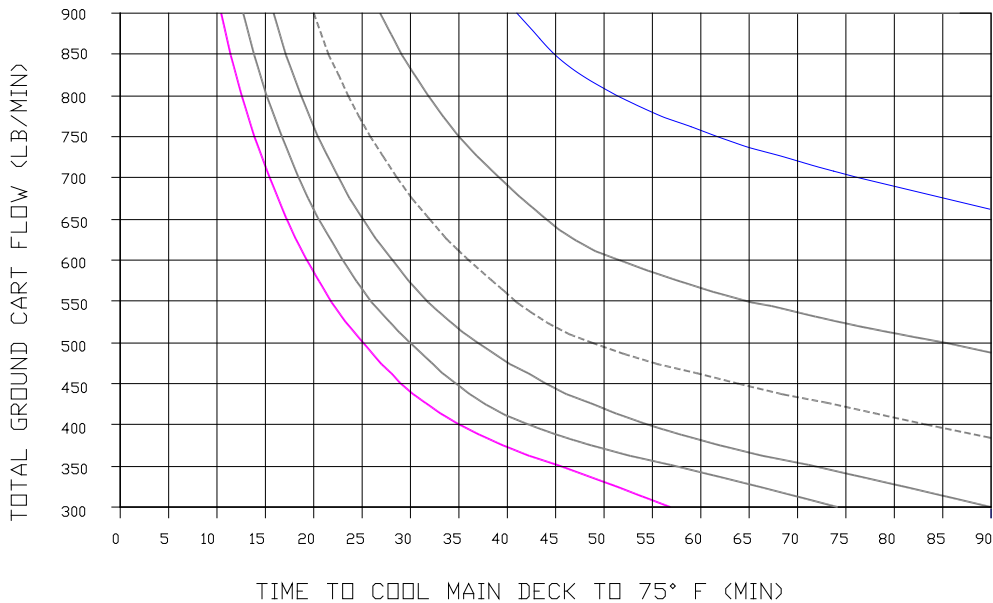

### LEGEND:

- |                     |                            |                     |                             |
|---------------------|----------------------------|---------------------|-----------------------------|
| — (solid magenta) — | 35 DEGREES F (2 DEGREES C) | ----- (dashed grey) | 50 DEGREES F (10 DEGREES C) |
| ----- (dashed grey) | 40 DEGREES F (4 DEGREES C) | ----- (solid grey)  | 55 DEGREES F (13 DEGREES C) |
| ----- (solid grey)  | 45 DEGREES F (7 DEGREES C) | ----- (solid blue)  | 60 DEGREES F (16 DEGREES C) |

### NOTE:

THIS GRAPH SHOWS THE TIME REQUIRED TO COOL THE MAIN DECK FROM 115°F (46°C) TO 75°F (24°C) AS A FUNCTION OF PRE-CONDITIONAL AIR FLOW AND TEMPERATURE, AT THE AIRPLANE'S GROUND AIR CONNECTORS, FOR THE CONDITIONS STATED.

## 5.6.6 Ground Conditioned Air Requirements – Cooling, Pull-Down: Model 777F

### CONDITIONS:

- ALL EXTERIOR DOORS AND WINDOWS CLOSED
- OUTSIDE TEMPERATURE 103° F (39° C)
- MAIN DECK SOLAR LOAD: 0 BTU/MIN – MAIN DECK HAS FEW WINDOWS; SUPERNUMERARY AREA IS NEGLIGIBLE
- MAIN DECK ELECTRICAL LOAD: 75 BTU/MIN – MAXIMUM HEAT DISSIPATION FROM CARGO LIGHTING
- RECIRCULATION FANS OFF
- MAIN DECK (MD) CHILLER HEAT DISSIPATION: 0 BTU/MIN – NO MD CHILLER
- NO HEAT GENERATING CARGO
- INITIAL CABIN TEMPERATURE: 115° F (46° C)
- SKIN TEMPERATURE: 118° F (48° C)
- MAIN DECK FLOW SWITCH: SELECTED TO NORMAL
- FORWARD CARGO AIR CONDITIONING (FCAC): SELECTED ‘ON’ WITH 14.6% OF TOTAL FLOW
- AFT CARGO AIR CONDITIONING (ACAC): ASSUMED ‘OFF’ (CUSTOMER OPTION)
- MAIN DECK HEAT TRANSFER COEFFICIENT IS 27.2 BTU/MIN\*F WITH A 10% FLOOR HEAT TRANSFER FACTOR. DOES NOT INCLUDE THE RIGID CARGO BARRIER.

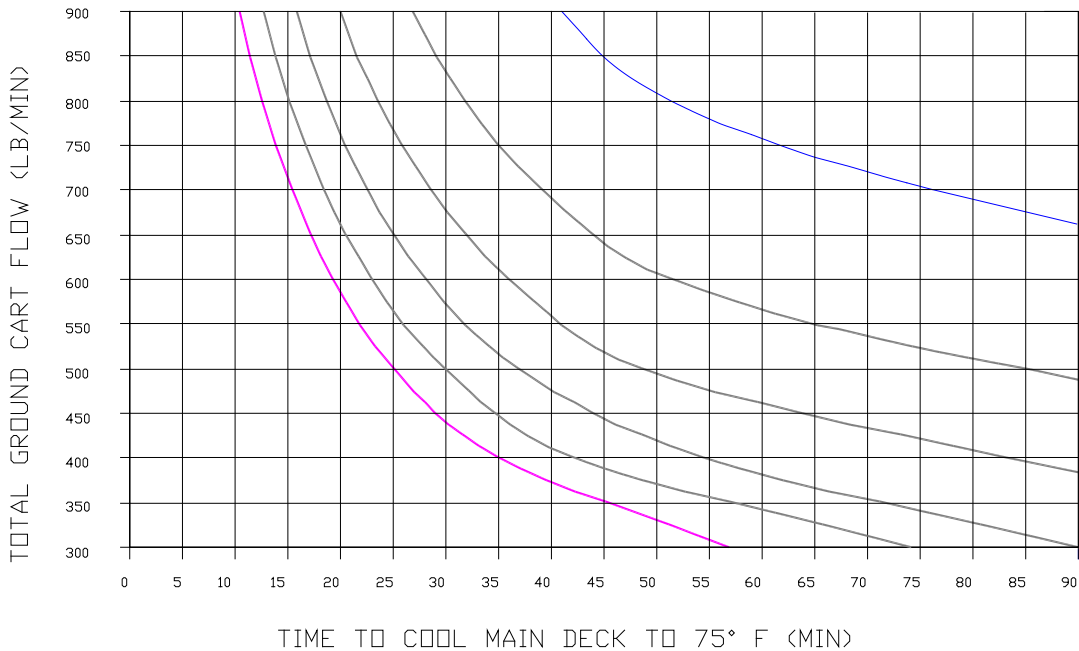

### LEGEND:

- |                     |                            |                   |                             |
|---------------------|----------------------------|-------------------|-----------------------------|
| — (solid magenta) — | 35 DEGREES F (2 DEGREES C) | — (solid grey) —  | 50 DEGREES F (10 DEGREES C) |
| — (dashed grey) —   | 40 DEGREES F (4 DEGREES C) | — (dashed grey) — | 55 DEGREES F (13 DEGREES C) |
| — (dash-dot grey) — | 45 DEGREES F (7 DEGREES C) | — (solid blue) —  | 60 DEGREES F (16 DEGREES C) |

### NOTE:

THIS GRAPH SHOWS THE TIME REQUIRED TO COOL THE MAIN DECK FROM 115°F (46°C) TO 75°F (24°C) AS A FUNCTION OF PRE-CONDITIONAL AIR FLOW AND TEMPERATURE, AT THE AIRPLANE'S GROUND AIR CONNECTORS, FOR THE CONDITIONS STATED.

## 5.7 CONDITIONED AIR REQUIREMENTS

### 5.7.1 Total Ground Cart Flow – Ground Cart Supply Temperature: Model 777F

CONDITIONS:

- ALL EXTERIOR DOORS AND WINDOWS CLOSED.
- OUTSIDE TEMPERATURE: -40° F (-40° C).
- SOLAR LOAD: 0 BTU/MIN (MAIN DECK HAS FEW WINDOWS, WINDOWS, SUPERNUMERARY AREA IS NEGLIGIBLE).
- MAIN DECK ELECTRICAL LOAD: 0 BTU/MIN.
- RECIRCULATION FANS: SELECTED "OFF".
- CHILLERS: SELECTED "OFF".
- ANIMAL HEAT LOAD: 0 BTU/MIN.
- CABIN TEMPERATURE: MAINTAINED AT 75° F (24° C).
- SKIN TEMPERATURE: -40° F (-40° C).
- MAIN DECK FLOW SWITCH: SELECTED TO NORMAL.
- FORWARD CARGO AIR CONDITIONING (FCAC): SELECTED "ON" WITH 14.6% OF TOTAL FLOW.
- AFT CARGO AIR CONDITIONING (ACAC): SELECTED "OFF" CUSTOMER OPTION.
- MAIN DECK HEAT TRANSFER COEFFICIENT IS 27.2 BTU/MIN<sup>2</sup>F WITH A 10% FLOOR HEAT TRANSFER FACTOR DOES NOT INCLUDE THE RIGID CARGO BARRIER.

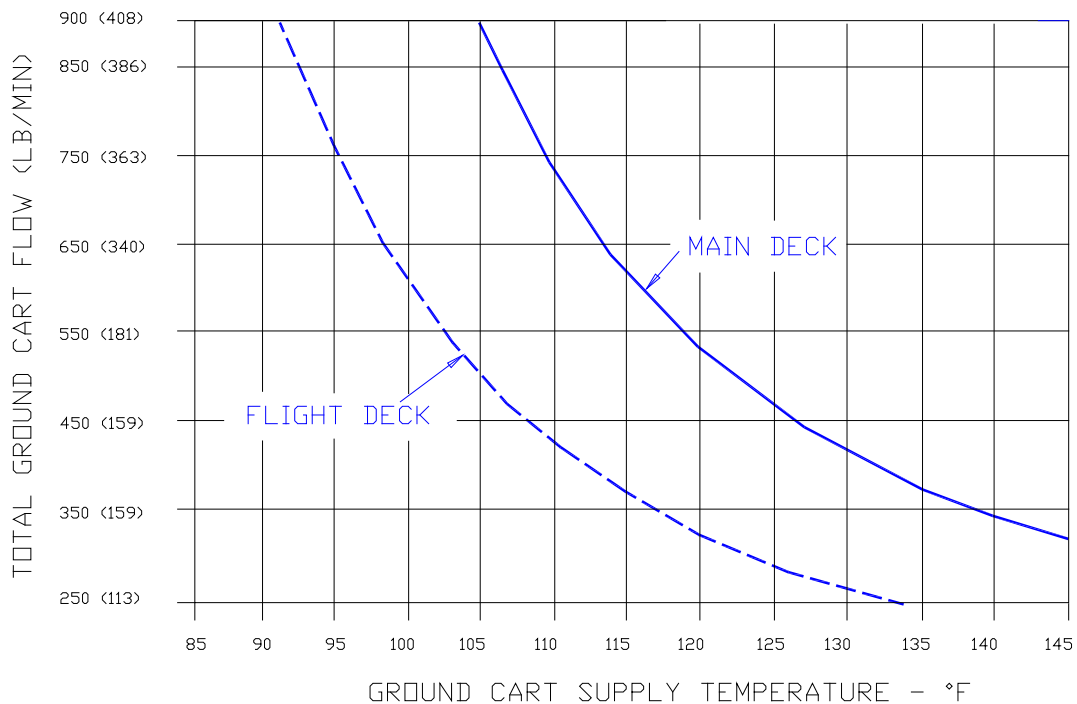

NOTE:

THIS GRAPH PROVIDES PREDICTED PRE-CONDITIONED AIR (PCA) TEMPERATURE AS A FUNCTION OF OF AIRFLOW THAT IS REQUIRED, AT THE AIRPLANE'S GROUND AIR CONNECTION (GAC), TO MAINTAIN THE MAIN CARGO DECK AT 74° F (24° C). THE CONDITIONS FOR WHICH THIS GRAPH WAS DEVELOPED ARE CONSIDERED WORST CASE "COLD" OPERATION.



## 5.7.2 Conditioned Air Flow Requirements - Steady State Airflow: Model 777-200LR, -300ER

### CONDITIONS FOR LINE (1):

ALL EXTERIOR DOORS AND WINDOWS CLOSED  
 OUTSIDE TEMPERATURE 103° F (39° C)  
 FULL SOLAR AND ELECTRICAL HEAT LOADS  
 RECIRCULATING FANS OFF  
 CHILLERS ON  
 426 PASSENGERS (777-200LR)  
 505 PASSENGERS (777-300ER)  
 CABIN TEMPERATURE MAINTAINED AT  
 75° F (24° C)

### CONDITIONS FOR LINE (2):

ALL EXTERIOR DOORS AND WINDOWS CLOSED  
 OUTSIDE TEMPERATURE -40° F (-40° C)  
 NO SOLAR AND ELECTRICAL HEAT LOADS  
 RECIRCULATING FANS OFF  
 CHILLERS OFF  
 NO PASSENGERS  
 CABIN TEMPERATURE MAINTAINED AT  
 75° F (24° C)

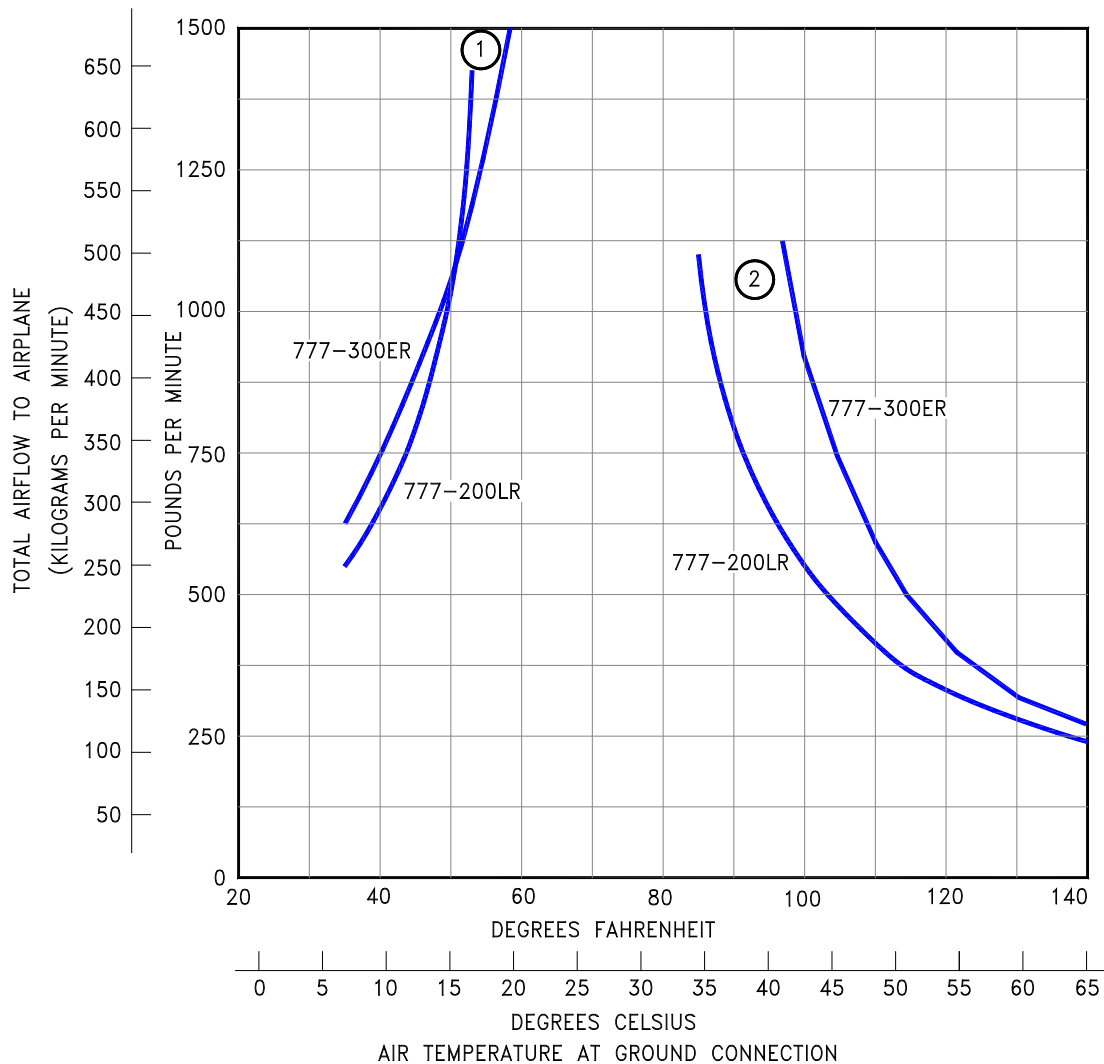

### NOTE:

THIS GRAPH SHOWS REQUIRED AIR TEMPERATURES AT THE GROUND AIR CONNECTION IN ORDER TO MAINTAIN CABIN TEMPERATURE AT 75°F (24°C)

### 5.7.3 Conditioned Air Flow Requirements - Steady State Airflow: Model 777F

CONDITIONS:

- ALL EXTERIOR DOORS AND WINDOWS CLOSED.
- OUTSIDE TEMPERATURE: 103° F (39° C).
- FULL SOLAR LOAD: 0 BTU/MIN (MAIN DECK HAS FEW WINDOWS, SUPERNUMERARY AREA IS NEGLIGABLE).
- MAIN DECK ELECTRICAL LOAD: 75 BTU/MIN - MAXIMUM HEAT DISSIPATION FROM CARGO LIGHTING.
- RECIRCULATION FANS: SELECTED "OFF".
- MAIN DECK CHILLER: 0 BTU/MIN - NO MD CHILLER, SUPERNUMERARY ZONE HAS CHILLER.
- MAXIMUM ANIMAL HEAT LOAD: 2100 BTU/MIN.
- CABIN TEMPERATURE: MAINTAINED AT 75° F (24° C).
- SKIN TEMPERATURE: 118° F (48° C).
- MAIN DECK FLOW SWITCH: SELECTED TO NORMAL.
- FORWARD CARGO AIR CONDITIONING (FCAC): SELECTED "ON" WITH 14.6% OF TOTAL FLOW.
- FLIGHT DECK FLOW SPLIT: 6.1% OF TOTAL FLOW.
- AFT CARGO AIR CONDITIONING (ACAC): ASSUMED "OFF" - CUSTOMER OPTION.
- MAIN DECK UNDERFLOOR AREA HEAT TRANSFER: 27.2 BTU/MIN - 10% APPROXIMATION WITH NO TRANSFER THROUGH RIGID BARRIER.

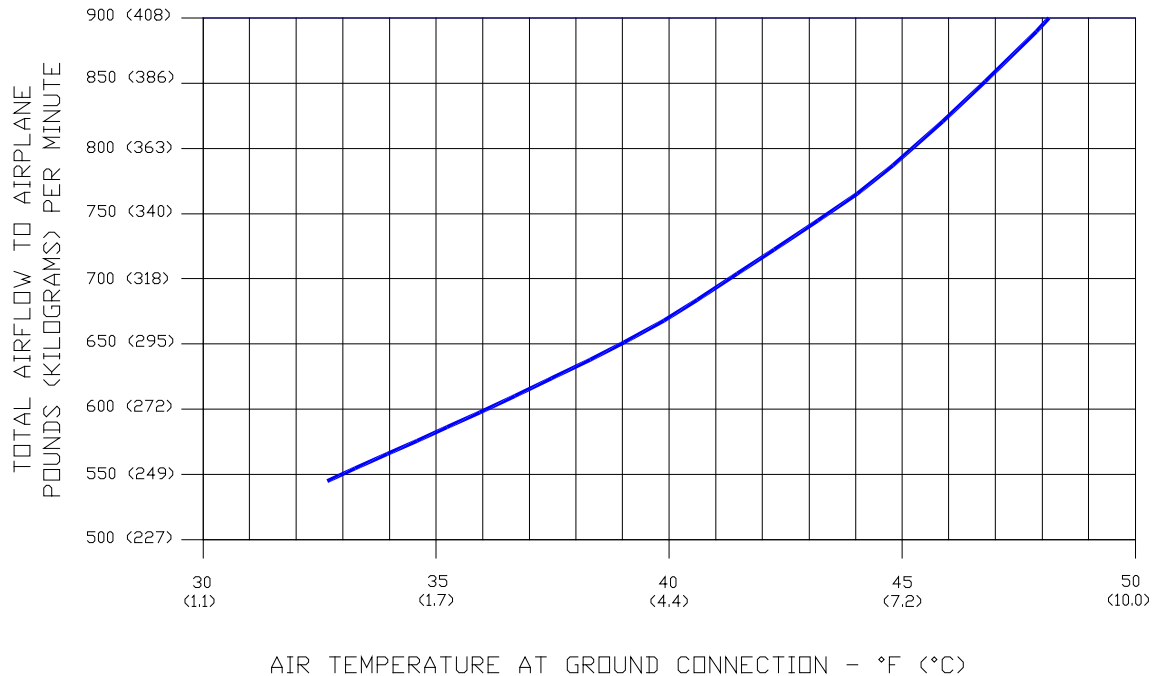

NOTE:

THIS GRAPH PROVIDES PREDICTED PRE-CONDITIONED AIR (PCA) TEMPERATURE AS A FUNCTION OF AIRFLOW THAT IS REQUIRED, AT THE AIRPLANE'S GROUND AIR CONNECTION (GAC), TO MAINTAIN THE MAIN CARGO DECK AT 75° F (24° C). THE CONDITIONS FOR WHICH THIS GRAPH WAS DEVELOPED ARE CONSIDERED WORST CASE "HOT DAY" OPERATION.

**5.7.4 Air Conditioning Gauge Pressure Requirements - Steady State  
Airflow: Model 777-200LR, -300ER**

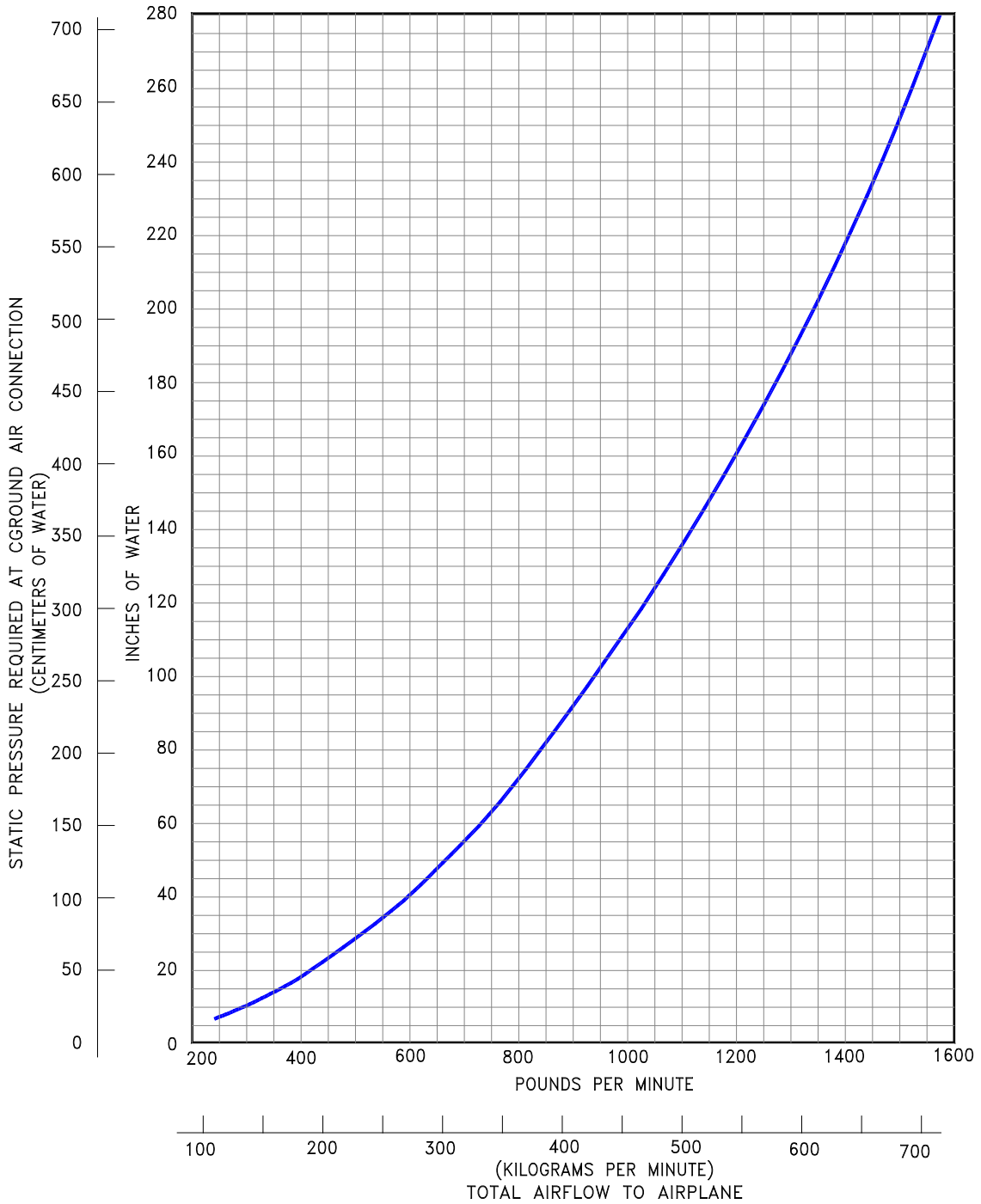

### 5.7.5 Conditioned Air Flow Requirements - Steady State BTU's: Model 777-200LR, -300ER

CONDITIONS FOR LINE (1) – HEATING  
 ALL EXTERIOR DOORS AND WINDOWS CLOSED  
 NO SOLAR AND ELECTRICAL HEAT LOADS  
 RECIRCULATING FANS OFF, CHILLERS OFF  
 NO OCCUPANTS  
 CABIN TEMPERATURE MAINTAINED AT  
 75° F (24° C)

CONDITIONS FOR LINE (2) – COOLING  
 ALL EXTERIOR DOORS AND WINDOWS CLOSED  
 FULL SOLAR ELECTRICAL HEAT LOADS  
 RECIRCULATING FANS OFF, CHILLERS ON  
 426 OCCUPANTS (777-200LR)  
 505 OCCUPANTS (777-300ER)  
 CABIN TEMPERATURE MAINTAINED AT  
 75° F (24° C)

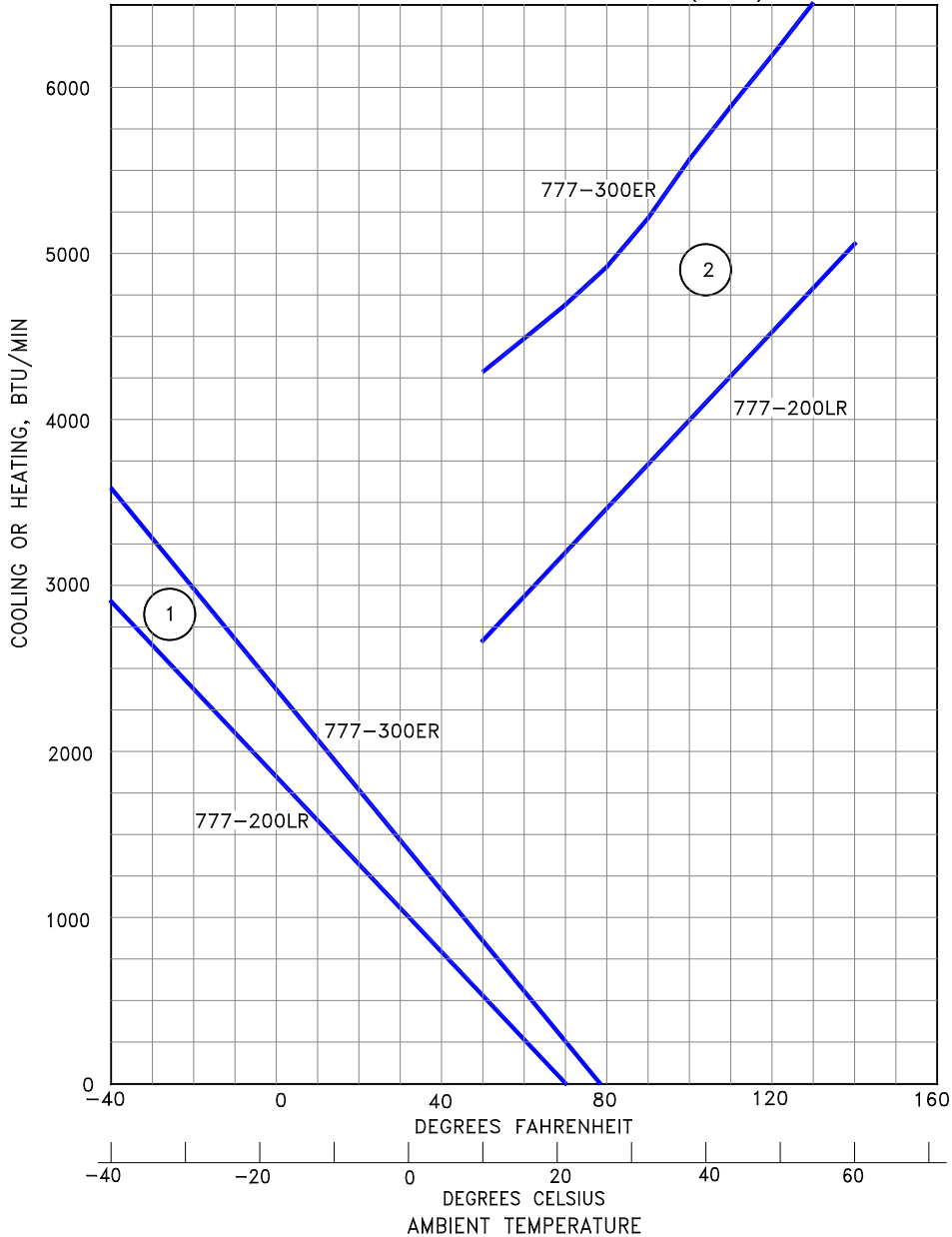

NOTE: THIS GRAPH SHOWS REQUIRED COOLING AND HEATING BTU'S AS A FUNCTION OF AMBIENT TEMPERATURE TO MAINTAIN CABIN TEMPERATURE AT 75°F (24°C)

## 5.7.6 Conditioned Air Flow Requirements - Steady State BTU's: Model 777F

### CONDITIONS:

- ALL EXTERIOR DOORS AND WINDOWS CLOSED.
- OUTSIDE TEMPERATURE: 103° F (39° C).
- SOLAR LOAD: 0 BTU/MIN (MAIN DECK HAS FEW WINDOWS, SUPERNUMERARY AREA IS NEGLIGABLE).
- MAIN DECK ELECTRICAL LOAD: 75 BTU/MIN - MAXIMUM HEAT DISSIPATION FROM CARGO LIGHTING.
- RECIRCULATION FANS: SELECTED "OFF".
- SUPERNUMERARY CHILLER: 51 BTU/MIN DISSIPATION.
- MAXIMUM ANIMAL HEAT LOAD: 2100 BTU/MIN.
- FLIGHT DECK OCCUPANTS: 4 CREW/OBSERVERS.
- CABIN TEMPERATURE: MAINTAINED AT 75° F (24° C).
- SUPERNUMERARY OCCUPANT HEAT LOAD: 4 OCCUPANTS
- SKIN TEMPERATURE: 118° F (48° C).
- FORWARD CARGO AIR CONDITIONING (FCAC): SELECTED "ON" WITH 14.6% OF TOTAL FLOW.
- AFT CARGO AIR CONDITIONING (ACAC): ASSUMED "OFF" - CUSTOMER OPTION.
- MAIN DECK HEAT TRANSFER COEFFICIENT IS 27.2 BTU/MIN\*°F WITH A 10% FLOOR HEAT TRANSFER FACTOR. DOES NOT INCLUDE THE RIGID CARGO BARRIER.
- FLIGHT DECK FLOW SPLIT: 6.1% OF TOTAL FLOW.

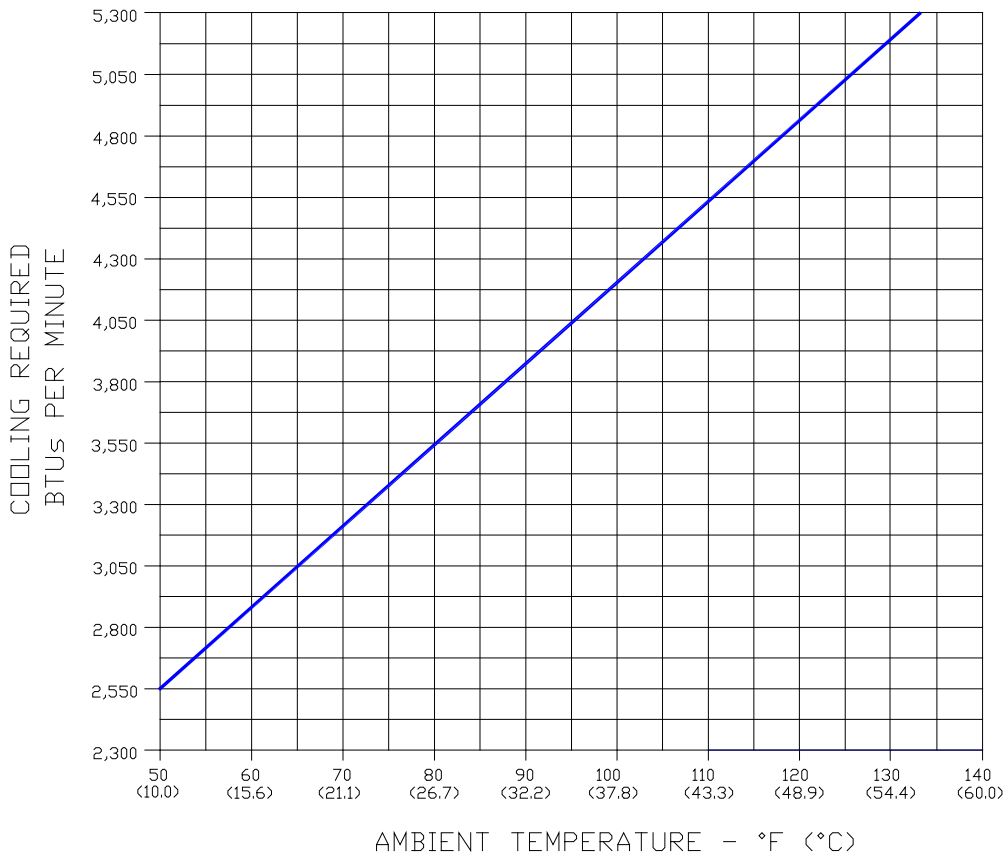

### NOTE:

THIS GRAPH PROVIDES PREDICTED PRE-CONDITIONED AIR (PCA) TEMPERATURE AS A FUNCTION OF AIRFLOW IS REQUIRED, AT THE AIRPLANE'S GROUND AIR CONNECTION (GAC), TO MAINTAIN THE MAIN CARGO DECK, FLIGHT DECK AND SUPERNUMERARY AT 75° F (24° C). THE CONDITIONS FOR WHICH THIS GRAPH WAS DEVELOPED ARE CONSIDERED WORST CASE COOLING OPERATION.

## 5.7.7 Conditioned Air Flow Requirements - Steady State BTU's: Model 777F

### CONDITIONS:

- ALL EXTERIOR DOORS AND WINDOWS CLOSED.
- OUTSIDE TEMPERATURE: -40° F (-40° C).
- SOLAR LOAD: 0 BTU/MIN (MAIN DECK HAS FEW WINDOWS, SUPERNUMERARY AREA IS NEGLIGABLE)
- MAIN DECK ELECTRICAL LOAD: 0 BTU/MIN.
- RECIRCULATION FANS: SELECTED "OFF".
- SUPERNUMERARY CHILLER: 51 BTU/MIN DISSIPATION.
- ANIMAL HEAT LOAD: 0 BTU/MIN.
- FLIGHT DECK OCCUPANTS: 2 CREW/OBSERVERS.
- CABIN TEMPERATURE: MAINTAINED AT 75° F (24° C).
- SKIN TEMPERATURE: 118° F (48° C).
- FORWARD CARGO AIR CONDITIONING (FCAC): SELECTED "ON" WITH 14.6% OF TOTAL FLOW.
- AFT CARGO AIR CONDITIONING (ACAC): ASSUMED "OFF" - CUSTOMER OPTION.
- MAIN DECK HEAT TRANSFER COEFFICIENT IS 27.2 BTU/MIN\*° F WITH A 10% FLOOR HEAT TRANSFER FACTOR. DOES NOT INCLUDE THE RIGID BARRIER.
- FLIGHT DECK FLOW SPLIT: 6.1% OF TOTAL FLOW.

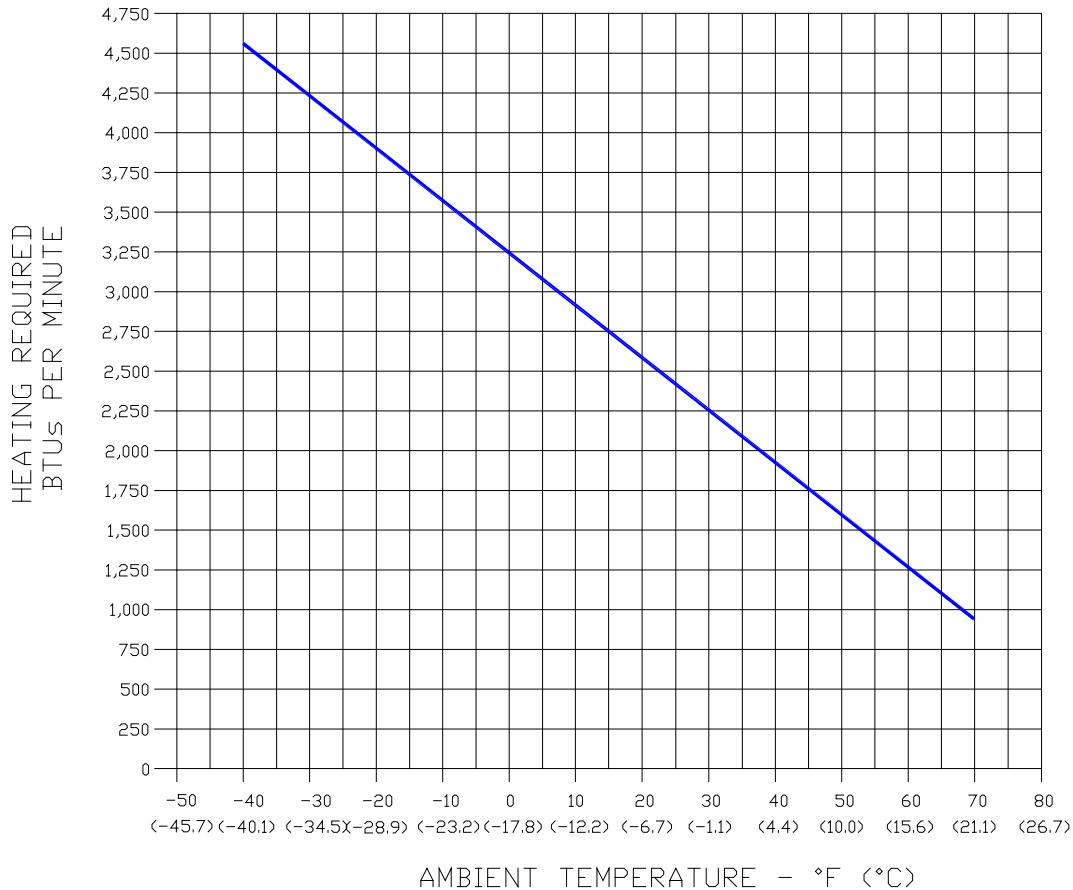

### NOTE:

THIS GRAPH PROVIDES PREDICTED PRE-CONDITIONED AIR (PCA) TEMPERATURE AS A FUNCTION OF AIRFLOW THAT IS REQUIRED, AT THE AIRPLANE'S GROUND AIR CONNECTION (GAC), TO MAINTAIN THE MAIN CARGO DECK, FLIGHT DECK AND SUPERNUMERARY AT 75° F (24° C). THE CONDITIONS FOR WHICH THIS GRAPH WAS DEVELOPED ARE CONSIDERED WORST CASE HEATING OPERATION.

## 5.8 GROUND TOWING REQUIREMENTS

### 5.8.1 Ground Towing Requirements - English and Metric Units: Model 777F

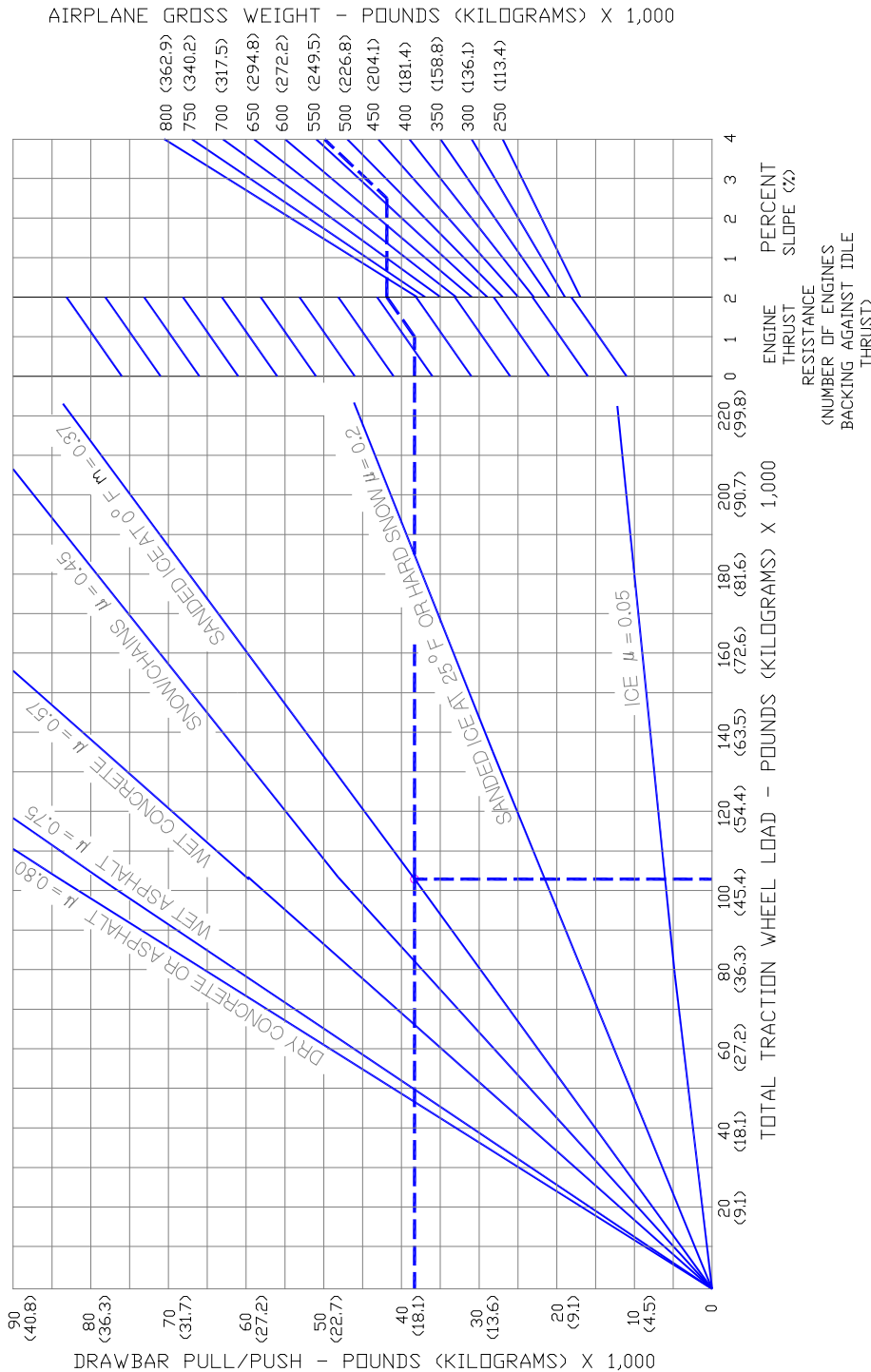

NOTES: 1. UNUSUAL BREAKAWAY CONDITIONS NOT SHOWN  
 2. STRAIGHT-LINE TOW  
 3. COEFFICIENTS OF FRICTION/μ ARE ESTIMATED FOR RUBBER-TIRED TOW VEHICLES

EXAMPLE: --- SHOWS A 777 WEIGHING 537,000 POUNDS (243,579 KILOGRAMS) BEING PUSHED UP A 2.5% SLOPE ON SANDED ICE AT 0° BACKING AGAINST ONE ENGINE AT IDLE THRUST. 38,385 POUNDS (17,411 KILOGRAMS) OF DRAW BAR PUSH AND A WHEEL TRACTION LOAD OF 103,743 POUNDS (47,057 KILOGRAMS) ARE REQUIRED FOR TOWING

---

## **6.0 JET ENGINE WAKE AND NOISE DATA**

### **6.1 JET ENGINE EXHAUST VELOCITIES AND TEMPERATURES**

This section shows exhaust velocity and temperature contours aft of the 777-200LR, 777-300ER, and 777 Freighter airplanes. The contours were calculated from a standard computer analysis using three-dimensional viscous flow equations with mixing of primary, fan, and free-stream flow. The presence of the ground plane is included in the calculations as well as engine tilt and toe-in. Mixing of flows from the engines is also calculated. The analysis does not include thermal buoyancy effects which tend to elevate the jet wake above the ground plane. The buoyancy effects are considered to be small relative to the exhaust velocity and therefore are not included.

The graphs show jet wake velocity and temperature contours for a representative engine. The results are valid for sea level, static, standard day conditions. The effect of wind on jet wakes was not included. There is evidence to show that a downwind or an upwind component does not simply add or subtract from the jet wake velocity, but rather carries the whole envelope in the direction of the wind. Crosswinds may carry the jet wake contour far to the side at large distances behind the airplane.



## 6.1.1 Jet Engine Exhaust Velocity Contours – Idle Thrust: Model 777-200LR

- NOTES:
- \* ENGINE THRUST AT IDLE SETTING
  - \* CONTOURS CALCULATED FROM COMPUTER DATA
  - \* STANDARD DAY
  - \* SEA LEVEL
  - \* NO WIND
  - \* 0% SLOPE
  - \* SINGLE ENGINE

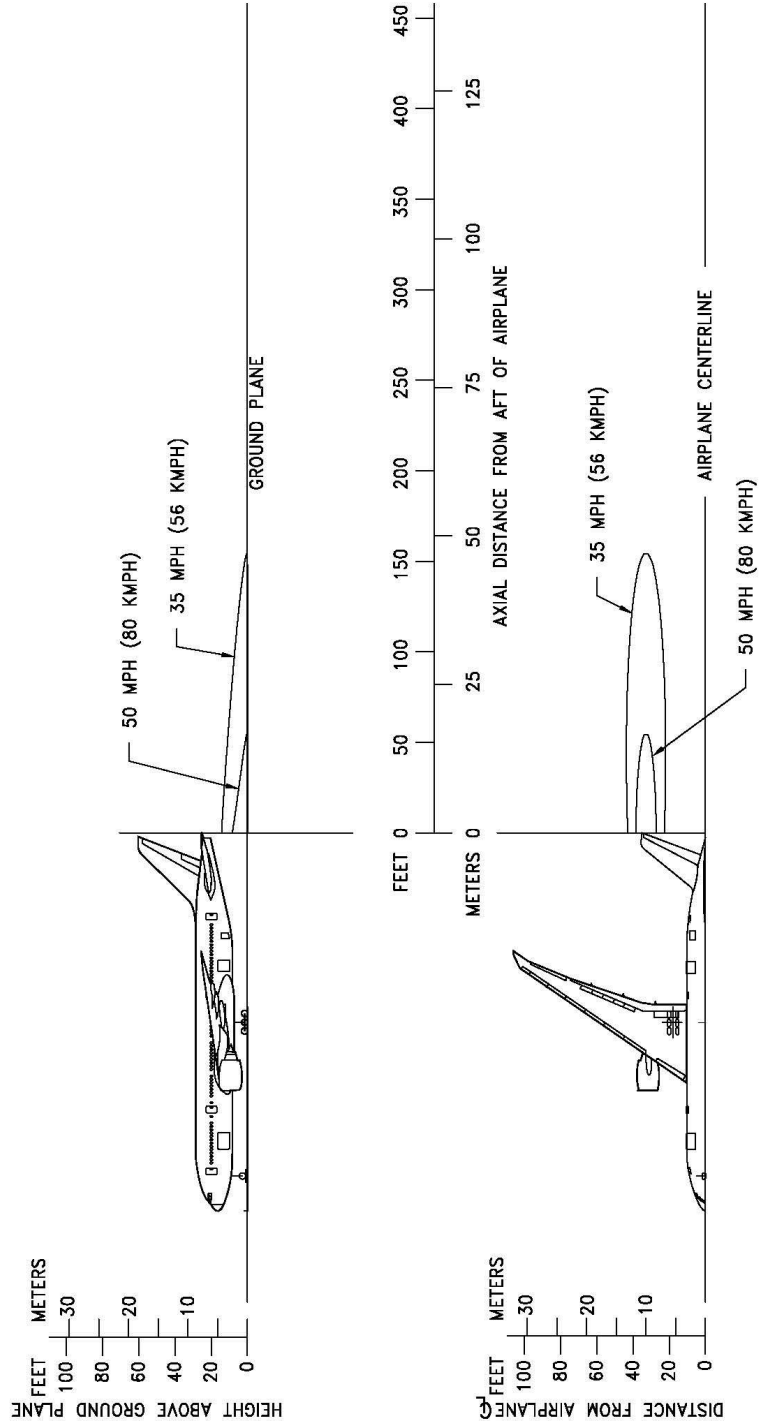

## 6.1.2 Jet Engine Exhaust Velocity Contours - Breakaway Thrust / Single Engine / MTW / 0% Slope: Model 777-200LR

- NOTES:
- \* ENGINE THRUST AT BREAKAWAY SETTING
  - \* CONTOURS CALCULATED FROM COMPUTER DATA
  - \* STANDARD DAY
  - \* SEA LEVEL
  - \* NO WIND
  - \* 0% SLOPE
  - \* SINGLE ENGINE
  - \* 10,368 LBF/ENGINE (MTW)

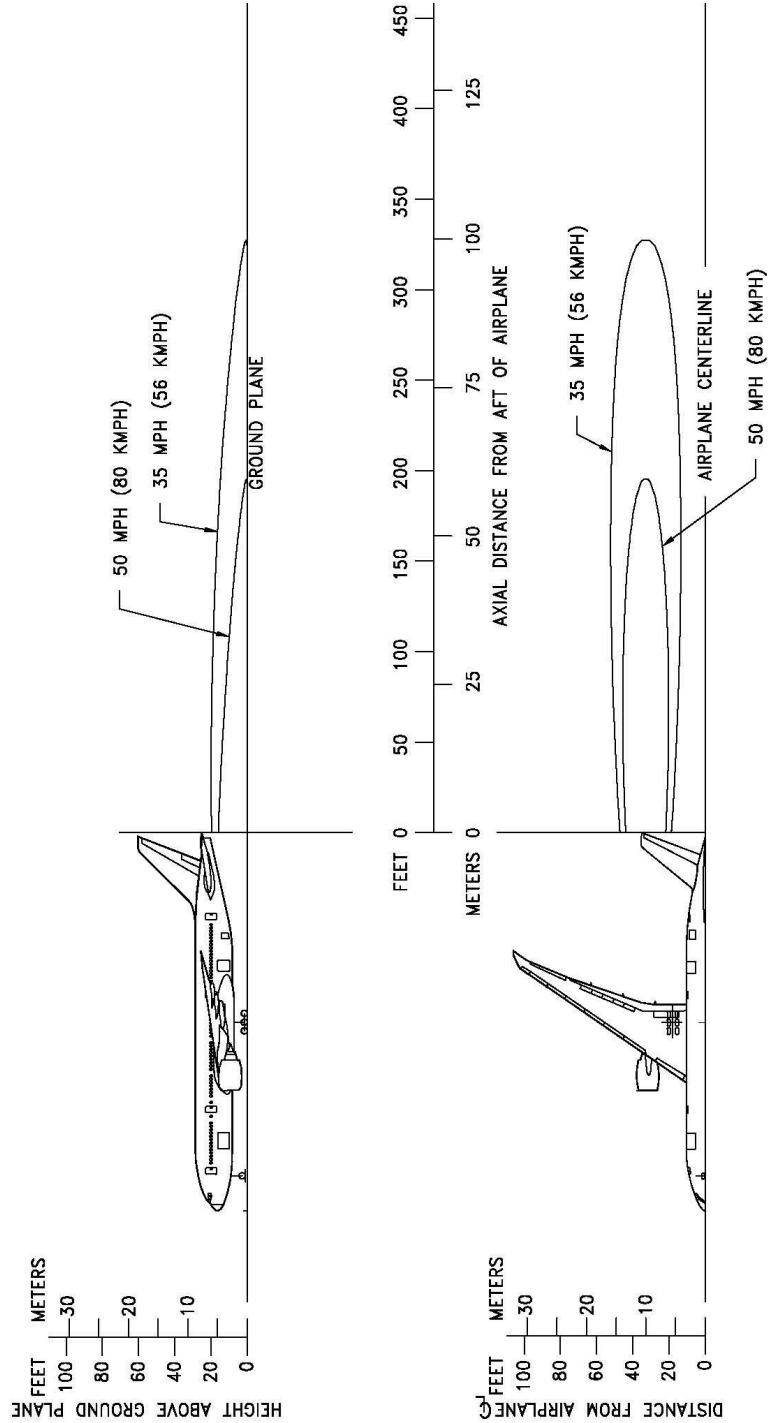

### 6.1.3 Jet Engine Exhaust Velocity Contours – Breakaway Thrust / Single Engine / MLW / 0% Slope: Model 777-200LR

- NOTES:
- \* ENGINE THRUST AT BREAKAWAY SETTING
  - \* CONTOURS CALCULATED FROM COMPUTER DATA
  - \* STANDARD DAY
  - \* SEA LEVEL
  - \* NO WIND
  - \* 0% SLOPE
  - \* SINGLE ENGINE
  - \* 6,224 LBF/ENGINE (MLW)

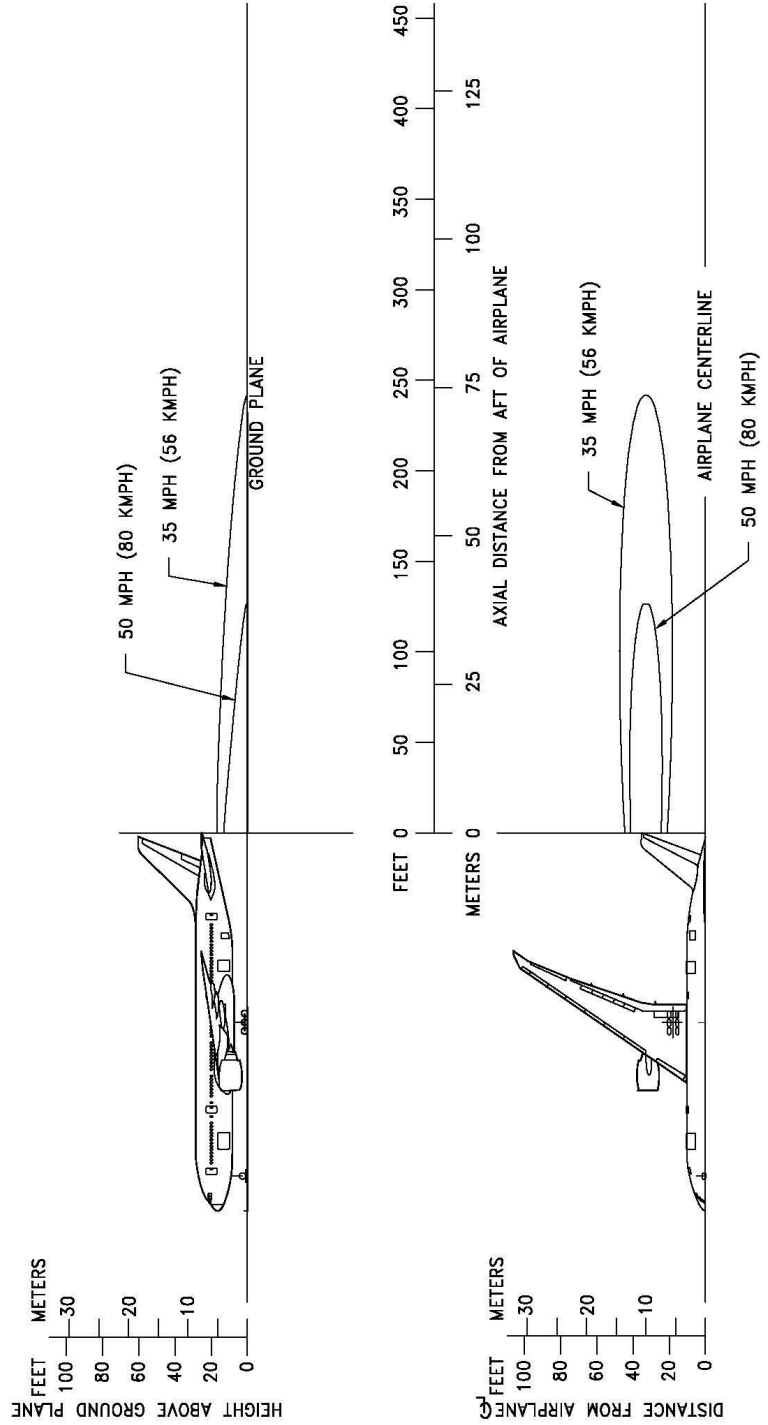

### 6.1.4 Jet Engine Exhaust Velocity Contours – Breakaway Thrust / Both Engines / MTW / 1% Slope: Model 777-200LR

- NOTES:
- \* ENGINE THRUST AT BREAKAWAY SETTING
  - \* CONTOURS CALCULATED FROM COMPUTER DATA
  - \* STANDARD DAY
  - \* SEA LEVEL
  - \* NO WIND
  - \* 1% SLOPE
  - \* BOTH ENGINES
  - \* 9,023 LBF/ENGINE (MTW)

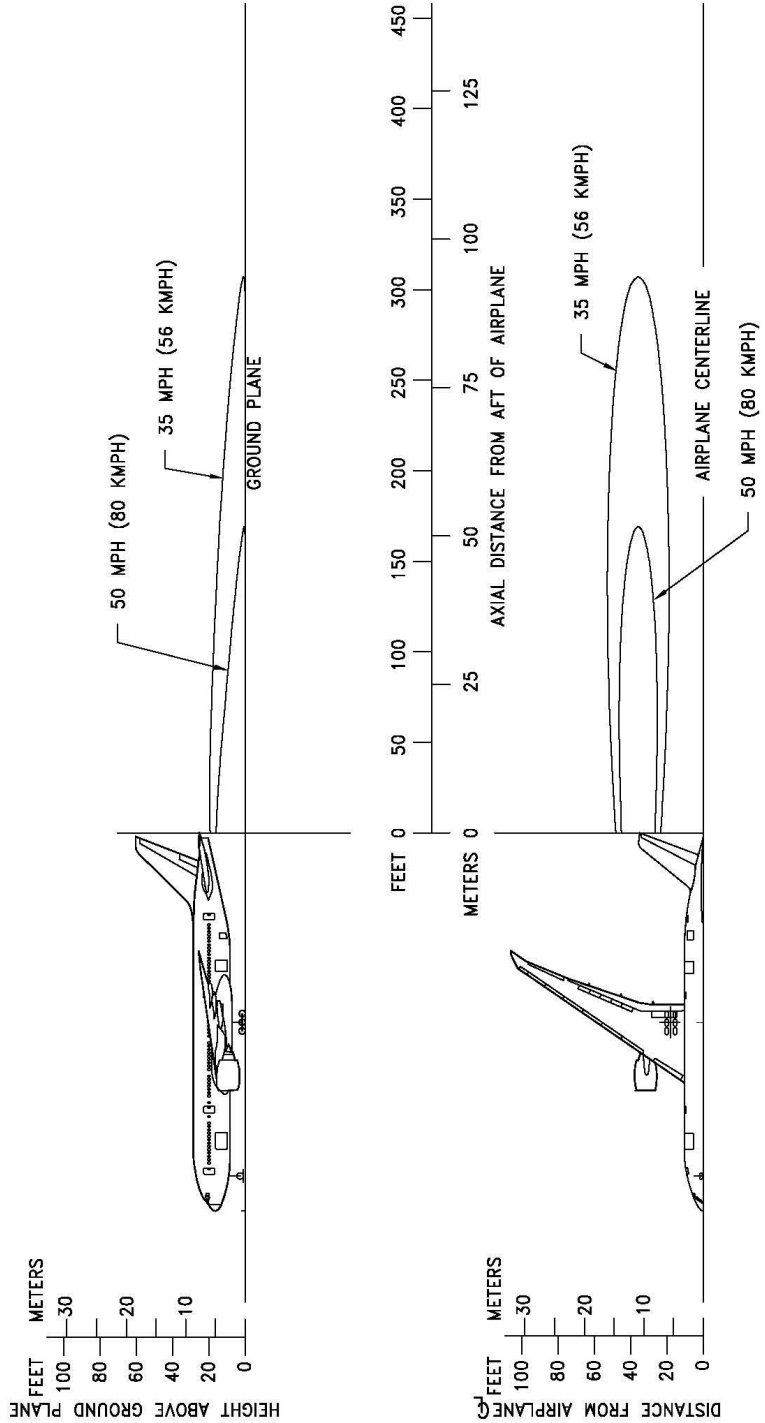

## 6.1.5 Jet Engine Exhaust Velocity Contours – Breakaway Thrust / Both Engines / MTW / 0% Slope: Model 777-200LR

- NOTES:
- \* ENGINE THRUST AT BREAKAWAY SETTING
  - \* CONTOURS CALCULATED FROM COMPUTER DATA
  - \* STANDARD DAY
  - \* SEA LEVEL
  - \* NO WIND
  - \* 0% SLOPE
  - \* BOTH ENGINES
  - \* 5,184 LBF/ENGINE (MTW)

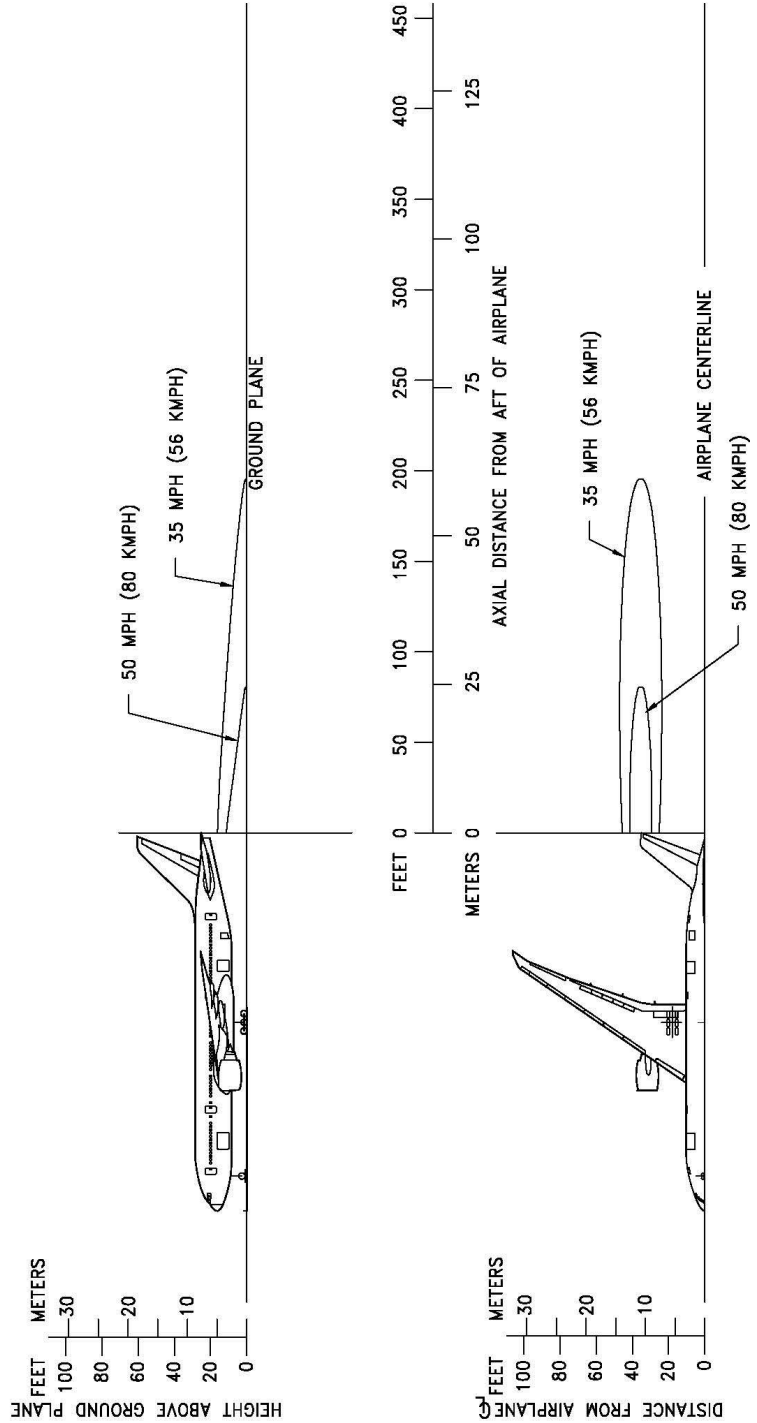

## 6.1.6 Jet Engine Exhaust Velocity Contours – Takeoff Thrust: Model 777-200LR

- NOTES:
- \* ENGINE THRUST AT TAKEOFF SETTING
  - \* CONTOURS CALCULATED FROM COMPUTER DATA
  - \* STANDARD DAY
  - \* SEA LEVEL
  - \* NO WIND
  - \* 0% SLOPE
  - \* 110,060 LBF/ENGINE

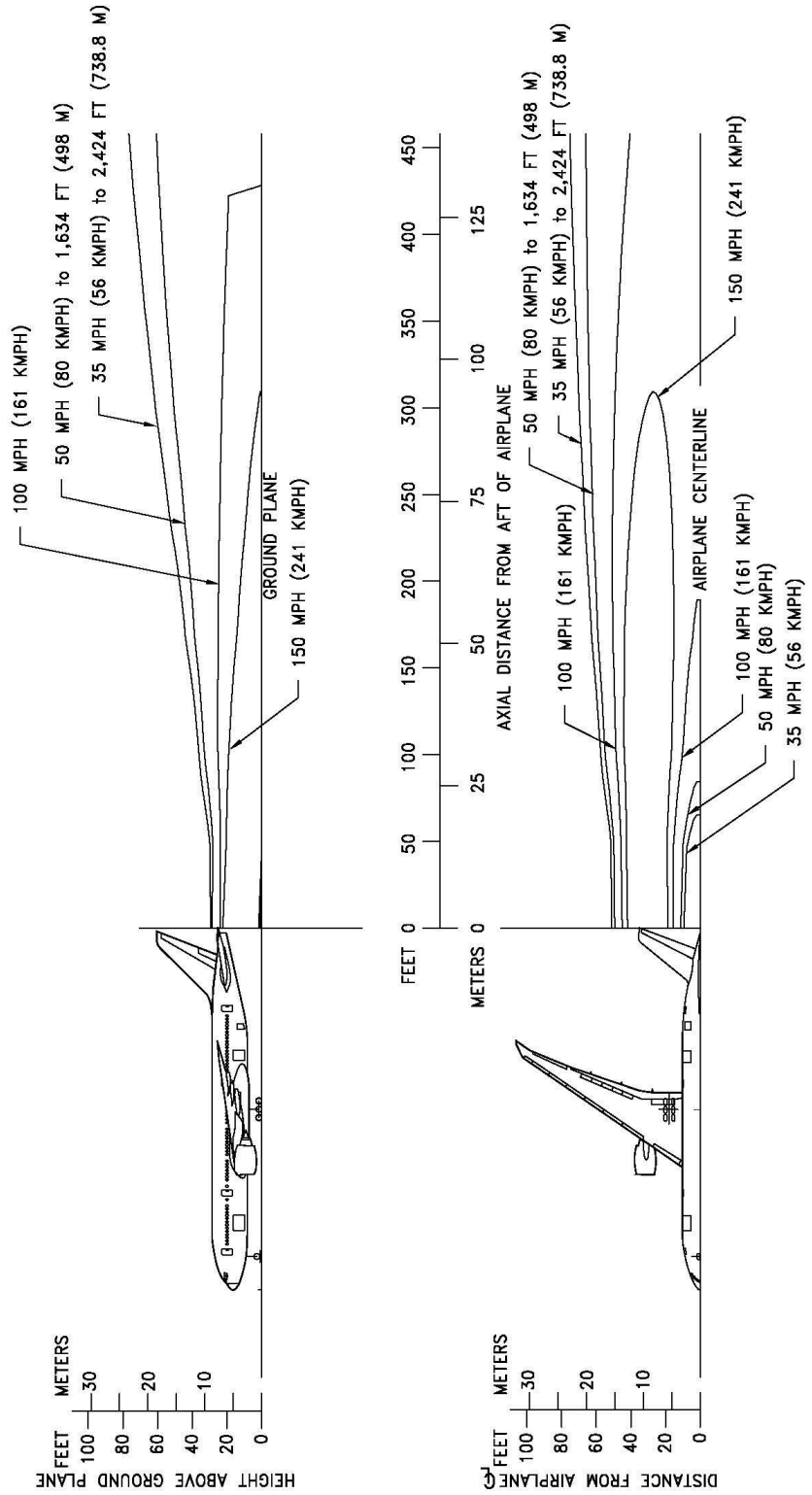

## 6.1.7 Jet Engine Exhaust Velocity Contours – Idle Thrust: Model 777-300ER

- NOTES:
- \* ENGINE THRUST AT IDLE SETTING
  - \* CONTOURS CALCULATED FROM COMPUTER DATA
  - \* STANDARD DAY
  - \* SEA LEVEL
  - \* NO WIND
  - \* 0% SLOPE
  - \* SINGLE ENGINE

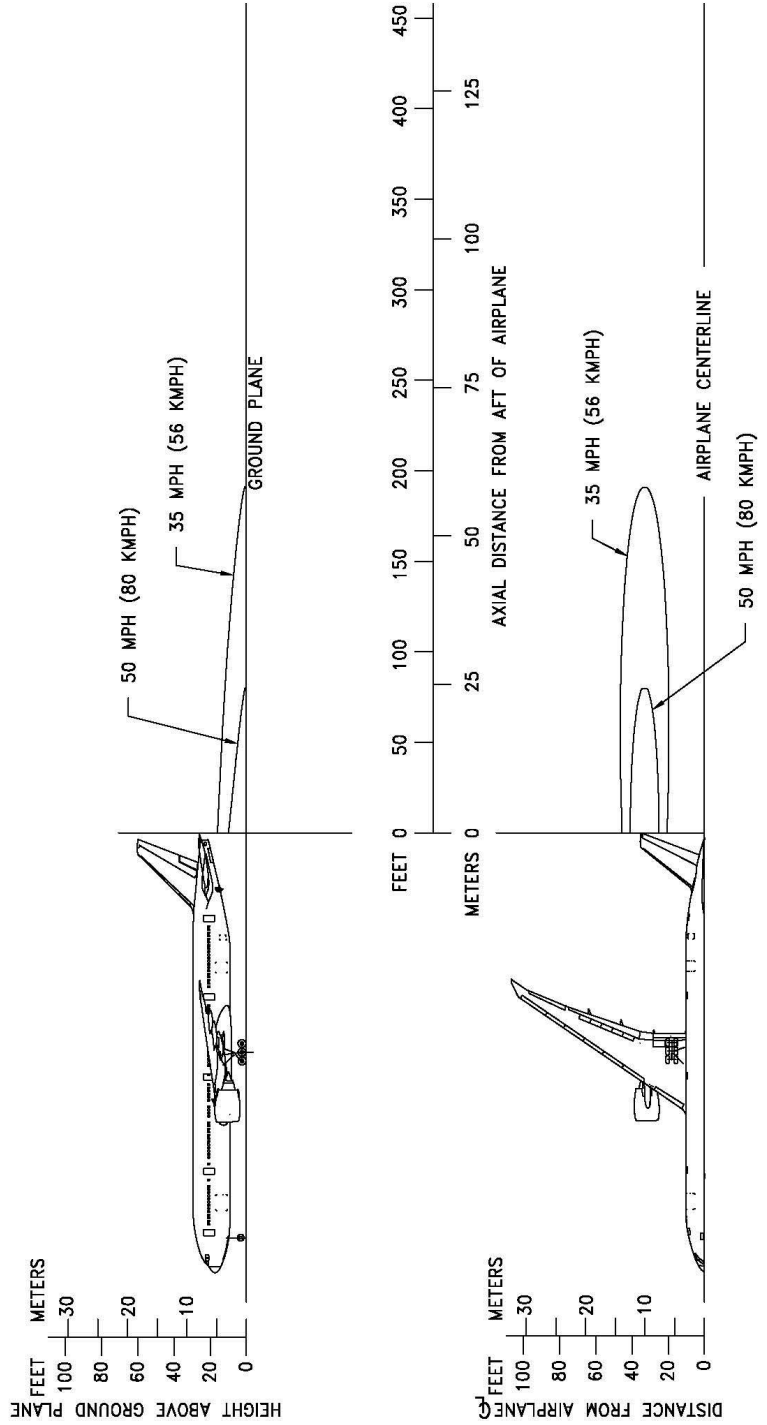

## 6.1.8 Jet Engine Exhaust Velocity Contours – BreakawayThrust / Single Engine / 0% Slope / MTW: Model 777-300ER

- NOTES:
- \* ENGINE THRUST AT BREAKAWAY SETTING
  - \* CONTOURS CALCULATED FROM COMPUTER DATA
  - \* STANDARD DAY
  - \* SEA LEVEL
  - \* NO WIND
  - \* 0% SLOPE
  - \* SINGLE ENGINE
  - \* 10,490 LBF/ENGINE (MTW)

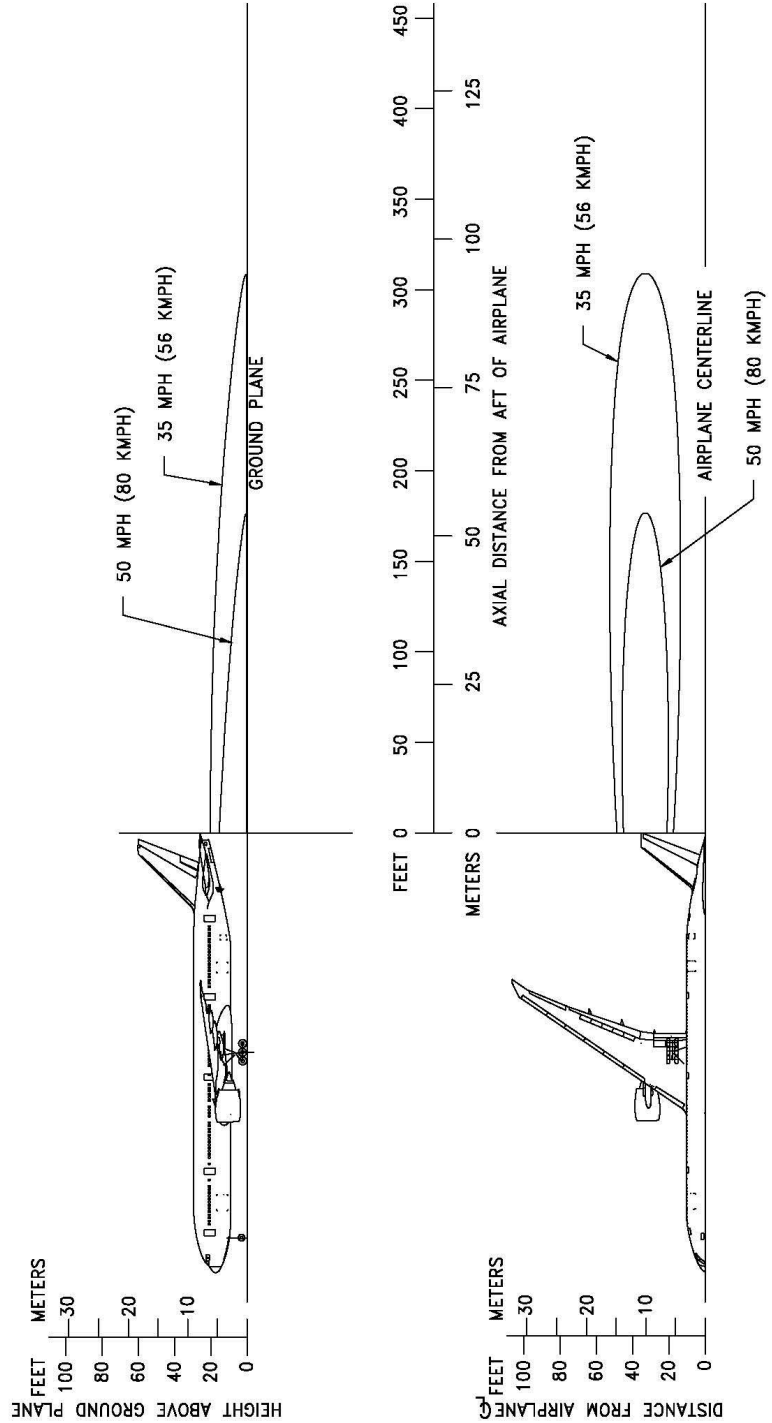



## 6.1.9 Jet Engine Exhaust Velocity Contours – BreakawayThrust / Single Engine / 0% Slope / MLW: Model 777-300ER

- NOTES:
- \* ENGINE THRUST AT BREAKAWAY SETTING
  - \* CONTOURS CALCULATED FROM COMPUTER DATA
  - \* STANDARD DAY
  - \* SEA LEVEL
  - \* NO WIND
  - \* 0% SLOPE
  - \* SINGLE ENGINE
  - \* 7,479 LBF/ENGINE (MLW)

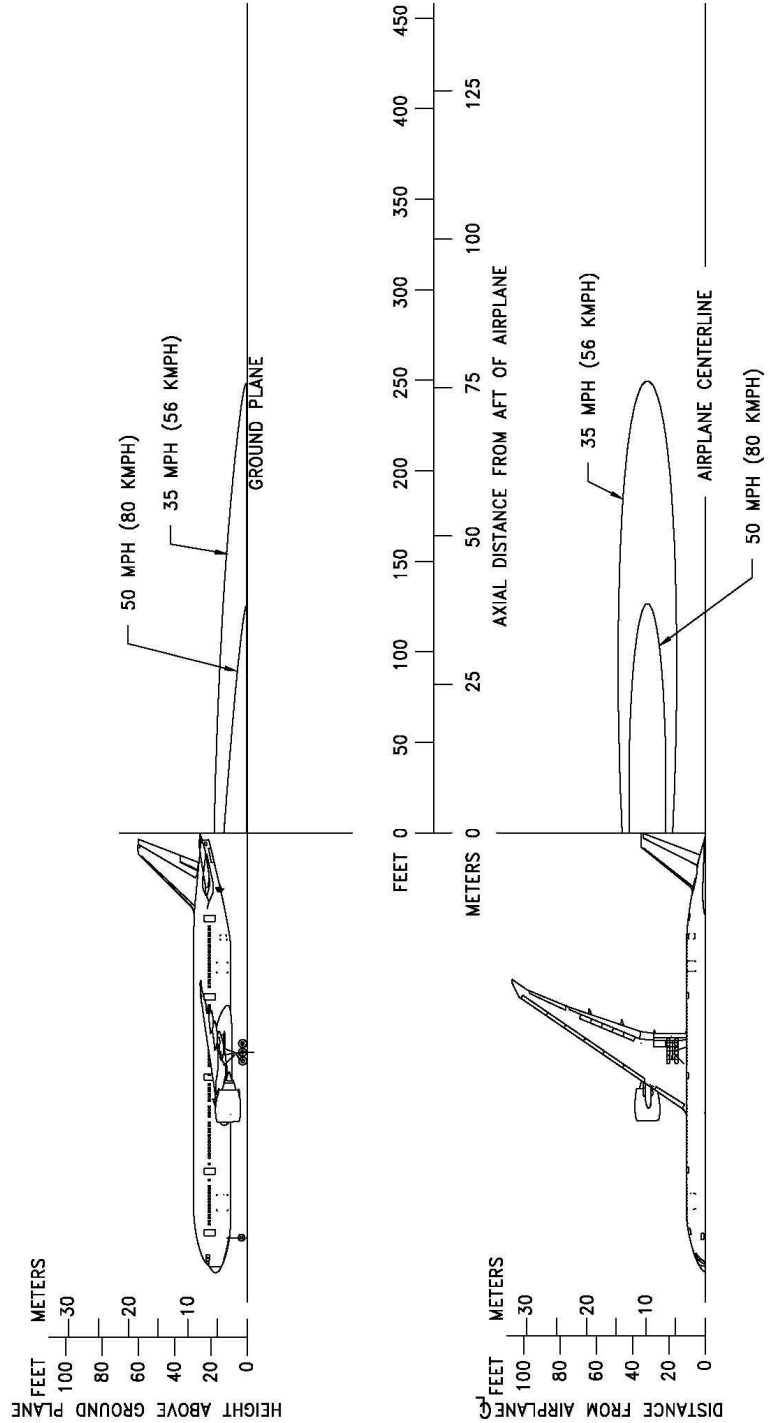

D6-58329-2

REV F

December 2022

6-10

### 6.1.10 Jet Engine Exhaust Velocity Contours – Breakaway Thrust / Both Engines / 0% Slope / MTW: Model 777-300ER

- NOTES:
- \* ENGINE THRUST AT BREAKAWAY SETTING
  - \* CONTOURS CALCULATED FROM COMPUTER DATA
  - \* STANDARD DAY
  - \* SEA LEVEL
  - \* NO WIND
  - \* 0% SLOPE
  - \* BOTH ENGINES
  - \* 5,245 LBF/ENGINE (MTW)

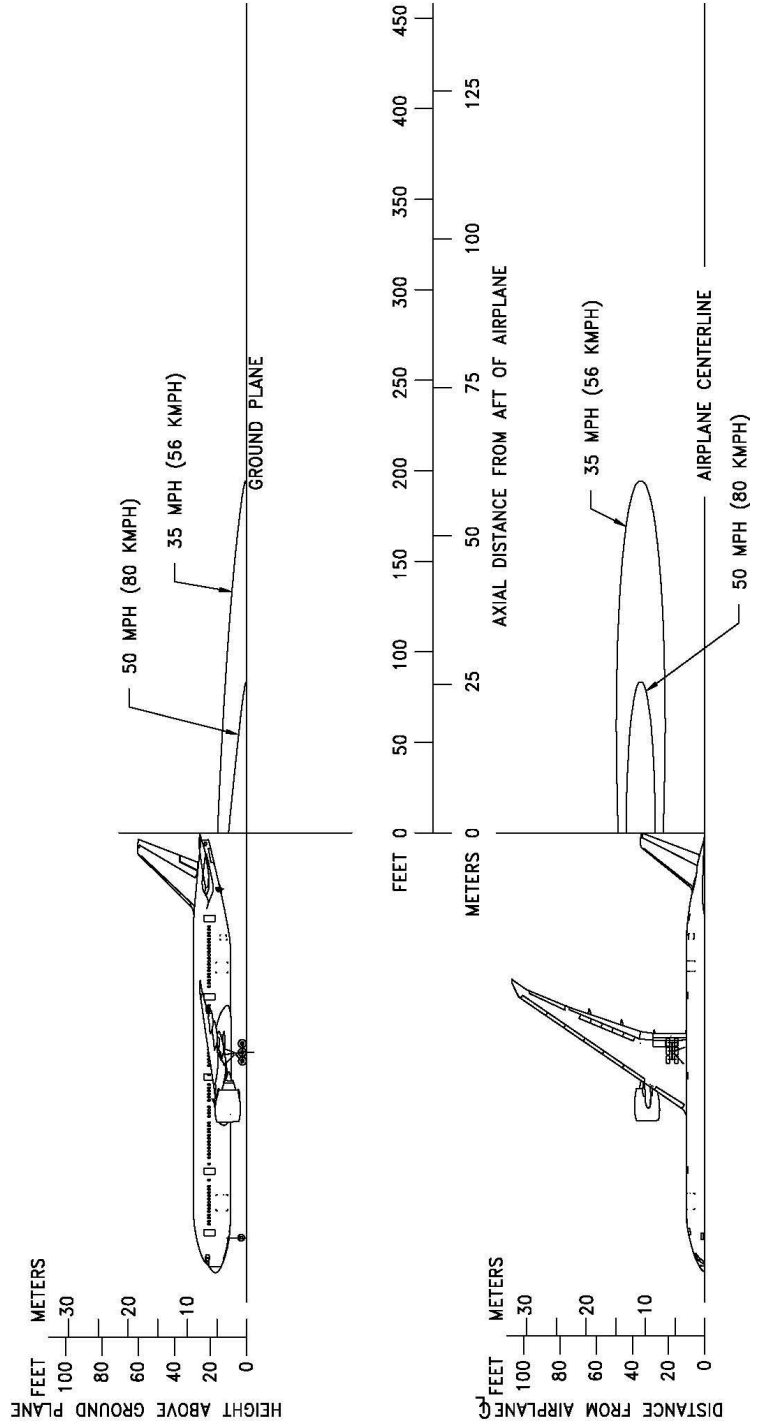

### 6.1.11 Jet Engine Exhaust Velocity Contours – Breakaway Thrust / Both Engines / 1% Slope / MTW: Model 777-300ER

- NOTES:
- \* ENGINE THRUST AT BREAKAWAY SETTING
  - \* CONTOURS CALCULATED FROM COMPUTER DATA
  - \* STANDARD DAY
  - \* SEA LEVEL
  - \* NO WIND
  - \* 1% SLOPE
  - \* BOTH ENGINES
  - \* 9,130 LBF/ENGINE (MTW)

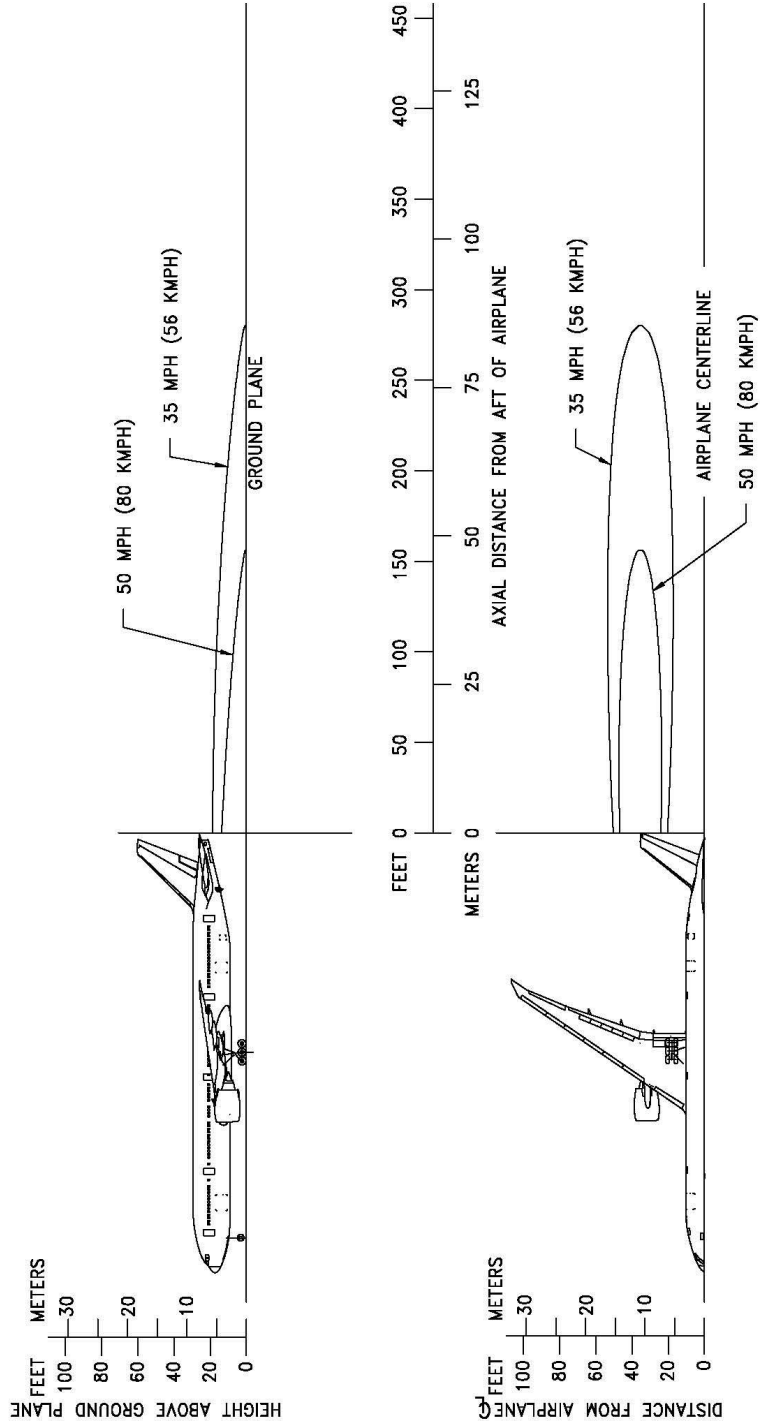

## 6.1.12 Jet Engine Exhaust Velocity Contours – Takeoff Thrust: Model 777-300ER

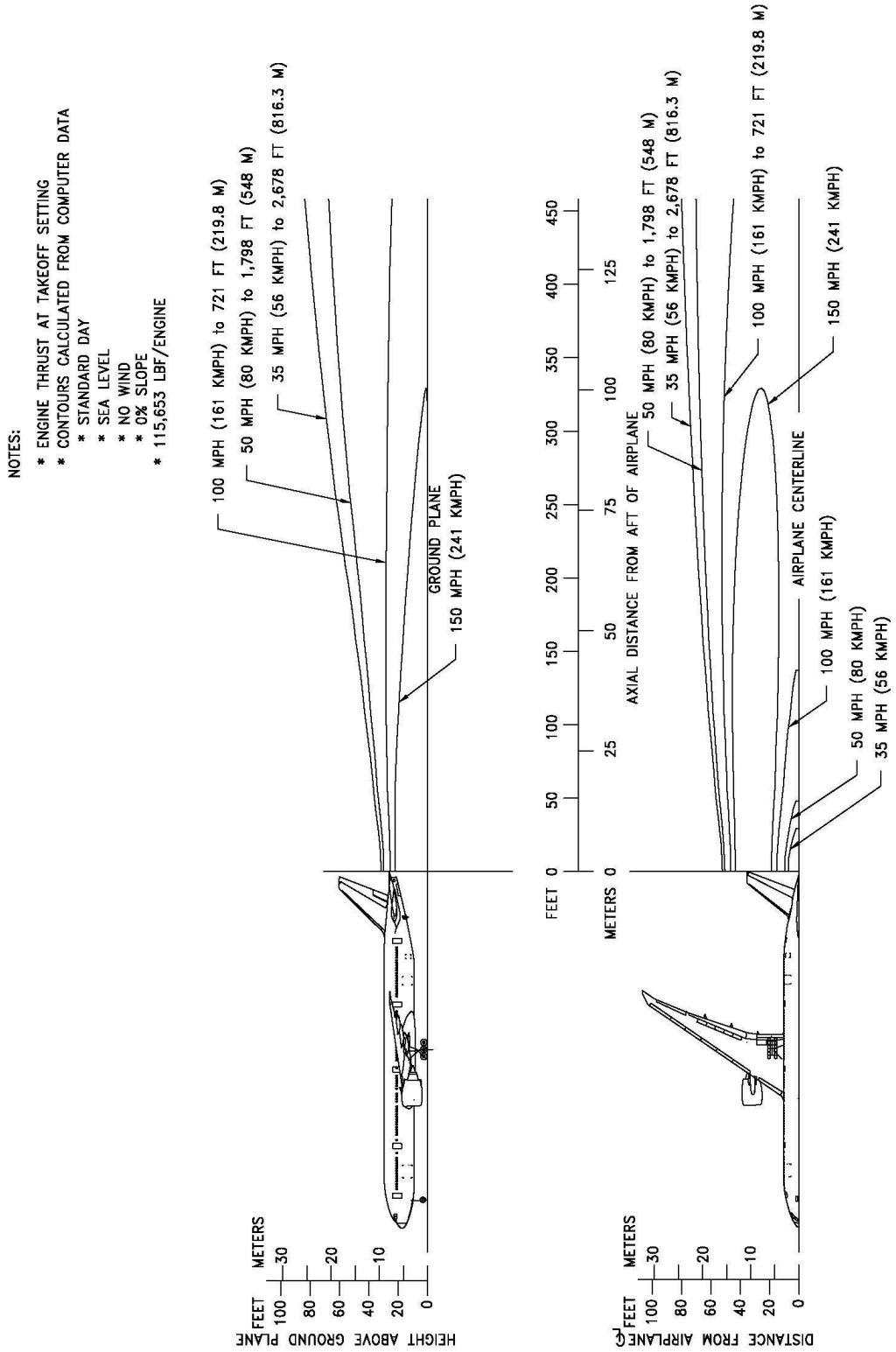

### 6.1.13 Inlet Hazard Areas: All Models

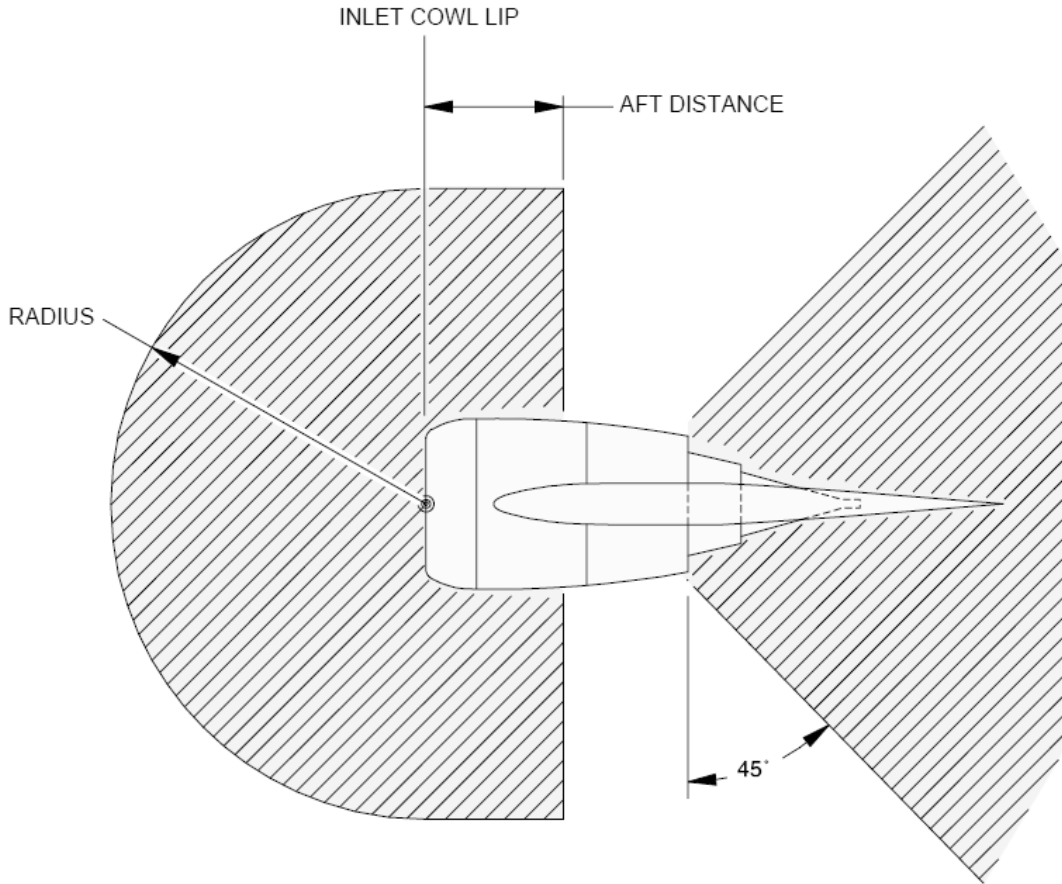

INLET HAZARD AREA

#### GE 90-100 Series Engines

	RADIUS		AFT DISTANCE	
	FT	M	FT	M
<b>IDLE THRUST</b>	15.0	4.6	5.0	1.5
<b>BREAKAWAY THRUST</b>	28.5	8.7	11.0	3.3
<b>TAKEOFF THRUST</b>	63.0	19.2	11.0	3.3

#### Trent 800 Series Engines

	RADIUS		AFT DISTANCE	
	FT	M	FT	M
<b>IDLE THRUST</b>	15.0	4.6	4.00	1.2
<b>BREAKAWAY THRUST</b>	27.0	8.2	10.0	3.0
<b>TAKEOFF THRUST</b>	63.0	19.2	10.0	3.0

---

## 6.2 AIRPORT AND COMMUNITY NOISE

Airport noise is of major concern to the airport and community planner. The airport is a major element in the community's transportation system and, as such, is vital to its growth. However, the airport must also be a good neighbor, and this can be accomplished only with proper planning. Since aircraft noise extends beyond the boundaries of the airport, it is vital to consider the impact on surrounding communities. Many means have been devised to provide the planner with a tool to estimate the impact of airport operations. Too often they oversimplify noise to the point where the results become erroneous. Noise is not a simple subject; therefore, there are no simple answers.

The cumulative noise contour is an effective tool. However, care must be exercised to ensure that the contours, used correctly, estimate the noise resulting from aircraft operations conducted at an airport.

The size and shape of the single-event contours, which are inputs into the cumulative noise contours, are dependent upon numerous factors. They include the following:

1. Operational Factors
  - a. Aircraft Weight-Aircraft weight is dependent on distance to be traveled, en route winds, payload, and anticipated aircraft delay upon reaching the destination.
  - b. Engine Power Settings-The rates of ascent and descent and the noise levels emitted at the source are influenced by the power setting used.
  - c. Airport Altitude-Higher airport altitude will affect engine performance and thus can influence noise.
2. Atmospheric Conditions-Sound Propagation
  - a. Wind-With stronger headwinds, the aircraft can take off and climb more rapidly relative to the ground. Also, winds can influence the distribution of noise in surrounding communities.
  - b. Temperature and Relative Humidity-The absorption of noise in the atmosphere along the transmission path between the aircraft and the ground observer varies with both temperature and relative humidity.
3. Surface Condition-Shielding, Extra Ground Attenuation (EGA)
  - a. Terrain-If the ground slopes down after takeoff or before landing, noise will be reduced since the aircraft will be at a higher altitude above ground. Additionally, hills, shrubs, trees, and large buildings can act as sound buffers.

All these factors can alter the shape and size of the contours appreciably. To demonstrate the effect of some of these factors, estimated noise level contours for two different operating conditions are shown below. These contours reflect a given noise level upon a ground level plane at runway elevation.

Condition 1

Landing		Takeoff
Maximum Structural Weight	Landing	Maximum Gross Takeoff
10-knot Headwind		Zero Wind
3° Approach		84 °F
84 °F		Humidity 15%
Humidity 15%		

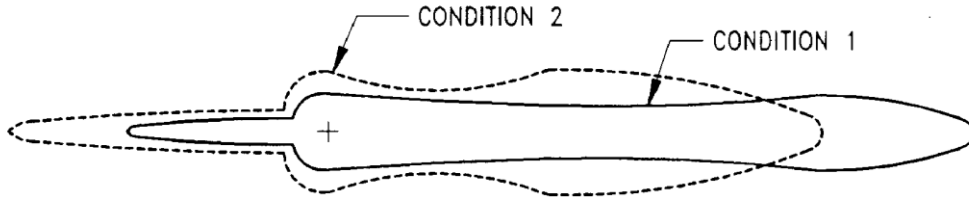

Condition 2

Landing		Takeoff
85% of Maximum Structural Landing Weight	Structural	80% of Maximum Gross Takeoff Weight
10-knot Headwind		10-knot Headwind
3° Approach		59 °F
59 °F		Humidity 70%
Humidity 70%		

As indicated from these data, the contour size varies substantially with operating and atmospheric conditions. Most aircraft operations are, of course, conducted at less than maximum gross weights because average flight distances are much shorter than maximum aircraft range capability and average load factors are less than 100%. Therefore, in developing cumulative contours for planning purposes, it is recommended that the airlines serving a particular city be contacted to provide operational information.

---

In addition, there are no universally accepted methods for developing aircraft noise contours or for relating the acceptability of specific zones to specific land uses. It is therefore expected that noise contour data for particular aircraft and the impact assessment methodology will be changing. To ensure that the best currently available information of this type is used in any planning study, it is recommended that it be obtained directly from the Office of Environmental Quality in the Federal Aviation Administration in Washington, D.C.

It should be noted that the contours shown herein are only for illustrating the impact of operating and atmospheric conditions and do not represent the single-event contour of the family of aircraft described in this document. It is expected that the cumulative contours will be developed as required by planners using the data and methodology applicable to their specific study.



---

## 7.0 PAVEMENT DATA

### 7.1 GENERAL INFORMATION

A brief description of the pavement charts that follow will help in their use for airport planning. Each airplane configuration is depicted with a minimum range of six loads imposed on the main landing gear to aid in interpolation between the discrete values shown. All curves for any single chart represent data based on rated loads and tire pressures considered normal and acceptable by current aircraft tire manufacturer's standards. Tire pressures, where specifically designated on tables and charts, are at values obtained under loaded conditions as certificated for commercial use.

Section 7.2 presents basic data on the landing gear footprint configuration, maximum design taxi loads, and tire sizes and pressures.

Maximum pavement loads for certain critical conditions at the tire-to-ground interface are shown in Section 7.3, with the tires having equal loads on the struts.

Pavement requirements for commercial airplanes are customarily derived from the static analysis of loads imposed on the main landing gear struts. The charts in Section 7.4 are provided in order to determine these loads throughout the stability limits of the airplane at rest on the pavement. These main landing gear loads are used as the point of entry to the pavement design charts, interpolating load values where necessary.

The flexible pavement design curves (Section 7.5) are based on procedures set forth in Instruction Report No. S-77-1, "Procedures for Development of CBR Design Curves," dated June 1977, and as modified according to the methods described in ICAO Aerodrome Design Manual, Part 3, Pavements, 2<sup>nd</sup> Edition, 1983, Section 1.1 (The ACN-PCN Method), and utilizing the alpha factors approved by ICAO in October 2007. Instruction Report No. S-77-1 was prepared by the U.S. Army Corps of Engineers Waterways Experiment Station, Soils and Pavements Laboratory, Vicksburg, Mississippi. The line showing 10,000 coverages is used to calculate Aircraft Classification Number (ACN).

The following procedure is used to develop the curves shown in Section 7.5:

1. Having established the scale for pavement depth at the bottom and the scale for CBR at the top, an arbitrary line is drawn representing 6,000 annual departures.
2. Values of the aircraft gross weight are then plotted.
3. Additional annual departure lines are drawn based on the load lines of the aircraft gross weights already established.
4. An additional line representing 10,000 coverages (used to calculate the flexible pavement Aircraft Classification Number) is also placed.

All Load Classification Number (LCN) curves (Sections 7.6 and 7.8) have been developed from a computer program based on data provided in International Civil Aviation

---

Organization (ICAO) document 9157-AN/901, Aerodrome Design Manual, Part 3, "Pavements", First Edition, 1977. LCN values are shown directly for parameters of weight on main landing gear, tire pressure, and radius of relative stiffness ( $\lambda$ ) for rigid pavement or pavement thickness or depth factor (h) for flexible pavement.

Rigid pavement design curves (Section 7.7) have been prepared with the Westergaard equation in general accordance with the procedures outlined in the Design of Concrete Airport Pavement (1955 edition) by Robert G. Packard, published by the American Concrete Pavement Association, 3800 North Wilke Road, Arlington Heights, Illinois 60004-1268. These curves are modified to the format described in the Portland Cement Association publication XP6705-2, Computer Program for Airport Pavement Design (Program PDILB), 1968, by Robert G. Packard.

The following procedure is used to develop the rigid pavement design curves shown in Section 7.7:

1. Having established the scale for pavement thickness to the left and the scale for allowable working stress to the right, an arbitrary load line is drawn representing the main landing gear maximum weight to be shown.
2. Values of the subgrade modulus (k) are then plotted.
3. Additional load lines for the incremental values of weight on the main landing gear are drawn on the basis of the curve for  $k = 300$ , already established.

The rigid pavement design curves (Section 7.9) have been developed based on methods used in the FAA Advisory Circular AC 150/5320-6D July 7, 1995. The following procedure is used to develop the curves shown in Section 7.9:

1. Having established the scale for pavement flexure strength on the left and temporary scale for pavement thickness on the right, an arbitrary load line is drawn representing the main landing gear maximum weight to be shown at 5,000 coverages.
2. Values of the subgrade modulus (k) are then plotted.
3. Additional load lines for the incremental values of weight are then drawn on the basis of the subgrade modulus curves already established.
4. The permanent scale for the rigid-pavement thickness is then placed. Lines for other than 5,000 coverages are established based on the aircraft pass-to-coverage ratio.

The ACN/PCN system (Section 7.10) as referenced in ICAO Annex 14, "Aerodromes," 8th Edition, July 2018, provides a standardized international airplane/pavement rating system replacing the various S, T, TT, LCN, AUW, ISWL, etc., rating systems used throughout the world. ACN is the Aircraft Classification Number and PCN is the Pavement Classification Number. An aircraft having an ACN equal to or less than the PCN can operate on the pavement subject to any limitation on the tire pressure. Numerically, the

ACN is two times the derived single-wheel load expressed in thousands of kilograms, where the derived single wheel load is defined as the load on a single tire inflated to 181 psi (1.25 MPa) that would have the same pavement requirements as the aircraft. Computationally, the ACN/PCN system uses the PCA program PDILB for rigid pavements and S-77-1 for flexible pavements to calculate ACN values.

The ACR-PCR system (Section 7.11) follows the proposed amendment to ICAO Annex 14 replacing the current ACN-PCN system. ACR is the Aircraft Classification Rating and PCR is the Pavement Classification Rating. An aircraft having an ACR equal to or less than the PCR can operate on the pavement subject to any limitation on the tire pressure. Numerically, the ACR is two times the derived single-wheel load expressed in hundreds of kilograms, where the derived single wheel load is defined as the load on a single tire inflated to 218 psi (1.5 MPa) that would have the same pavement requirements as the aircraft.

The method of pavement evaluation is left up to the airport with the results of their evaluation presented as follows:

PCR	PAVEMENT TYPE	SUBGRADE CATEGORY	TIRE CATEGORY	PRESSURE	EVALUATION METHOD
	R = Rigid	A = High	W = No Limit		T = Technical
	F = Flexible	B = Medium	X = To 254 psi (1.75 MPa)		U = Using Aircraft
		C = Low	Y = To 181 psi (1.25 MPa)		
		D = Ultra Low	Z = To 73 psi (0.5 MPa)		

ACN values for flexible pavements are calculated for the following four subgrade categories:

Code A - High Strength - CBR 15

Code B - Medium Strength - CBR 10

Code C - Low Strength - CBR 6

Code D - Ultra Low Strength - CBR 3

ACN values for rigid pavements are calculated for the following four subgrade categories:

Code A - High Strength,  $k = 552.6 \text{ pci (150 MN/m}^3\text{)}$

Code B - Medium Strength,  $k = 294.7 \text{ pci (80 MN/m}^3\text{)}$

Code C - Low Strength,  $k = 147.4 \text{ pci (40 MN/m}^3\text{)}$

Code D - Ultra Low Strength,  $k = 73.7 \text{ pci (20 MN/m}^3\text{)}$

---

ACR values at any mass on rigid and flexible pavements are calculated for the following four subgrade categories:

Code A - High Strength - Subgrade Modulus,  $E = 200 \text{ MPa}$  (29,008 psi)

Code B - Medium Strength - Subgrade Modulus,  $E = 120 \text{ MPa}$  (17,405 psi)

Code C - Low Strength - Subgrade Modulus,  $E = 80 \text{ MPa}$  (11,603 psi)

Code D - Ultra Low Strength - Subgrade Modulus,  $E = 50 \text{ MPa}$  (7,252 psi)

## 7.2 LANDING GEAR FOOTPRINT: MODEL 777-200LR, -300ER, 777F

NOT TO SCALE

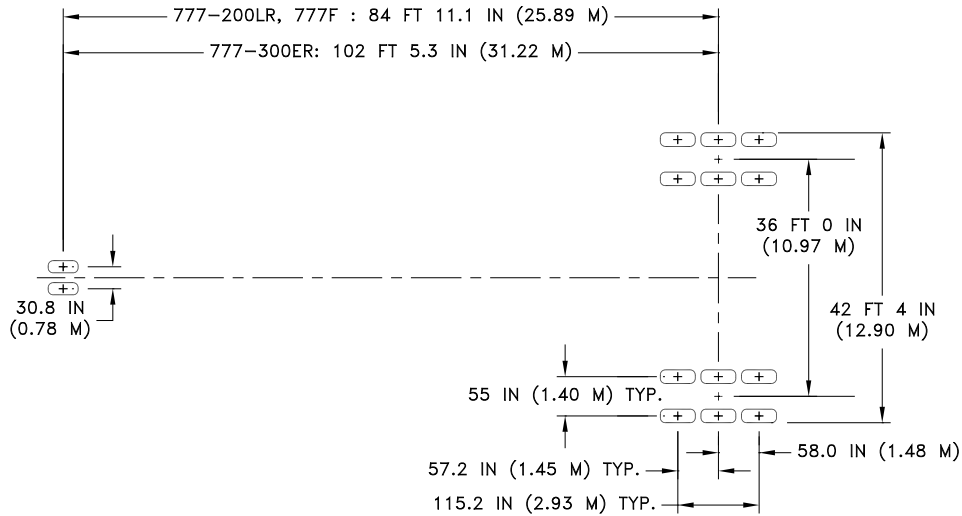

	UNITS	MODEL 777-200LR	MODEL 777F	MODEL 777-300ER
MAXIMUM DESIGN TAXI WEIGHT	LB	768,000	768,800	777,000
	KG	348,358	348,722	352,441
PERCENT OF WEIGHT ON MAIN GEAR	%	SEE SECTION 7.4		
NOSE GEAR TIRE SIZE	IN.	43 X 17.5 R 17, 32 PR		
NOSE GEAR TIRE PRESSURE	PSI	218	218	
	MPa	1.50	1.50	
MAIN GEAR TIRE SIZE	IN.	52 X 21 R 22, 36 PR		
MAIN GEAR TIRE PRESSURE	PSI	218	218	221
	MPa	1.50	1.50	1.52

D6-58329-2

REV F

December 2022

7-5

### 7.3 MAXIMUM PAVEMENT LOADS: MODEL 777-200LR, -300ER, 777F

$V_{NG}$  = MAXIMUM VERTICAL NOSE GEAR GROUND LOAD AT MOST FORWARD CENTER OF GRAVITY

$V_{MG}$  = MAXIMUM VERTICAL MAIN GEAR GROUND LOAD AT MOST AFT CENTER OF GRAVITY

H = MAXIMUM HORIZONTAL GROUND LOAD FROM BRAKING

**NOTE:** ALL LOADS CALCULATED USING AIRPLANE MAXIMUM DESIGN TAXI WEIGHT

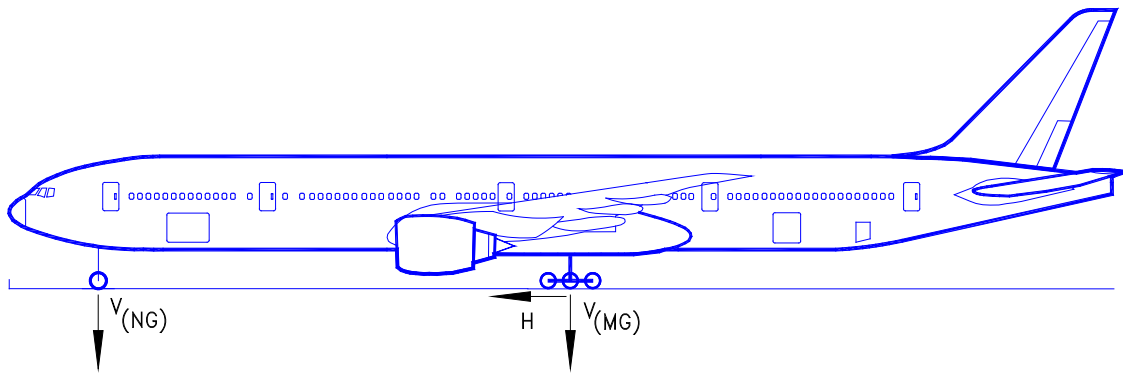

AIRPLANE MODEL	UNITS	MAX DESIGN TAXI WEIGHT	$V_{NG}$		$V_{MG}$ PER STRUT AT MAX LOAD AT STATIC AFT C.G.	H PER STRUT (4)	
			STATIC AT MOST FWD C.G.	STATIC + BRAKING 10 FT/SEC <sup>2</sup> DECEL		STEADY BRAKING 10 FT/SEC <sup>2</sup> DECEL	AT INSTANTANEOUS BRAKING ( $\mu = 0.8$ )
777-200LR	LB	768,000	68,269	115,317	352,435	119,270	281,924
	KG	348,358	30,966	52,307	159,862	54,100	127,879
777-300ER	LB	777,000	59,019	98,480	359,207	120,668	287,333
	KG	352,441	26,771	44,670	162,934	54,734	130,332
777F	LB	768,800	81,367	128,464	352,495	119,395	281,949
	KG	348,722	36,907	58,270	159,889	54,157	127,890

## 7.4 LANDING GEAR LOADING ON PAVEMENT

### 7.4.1 Landing Gear Loading on Pavement: Model 777-200LR

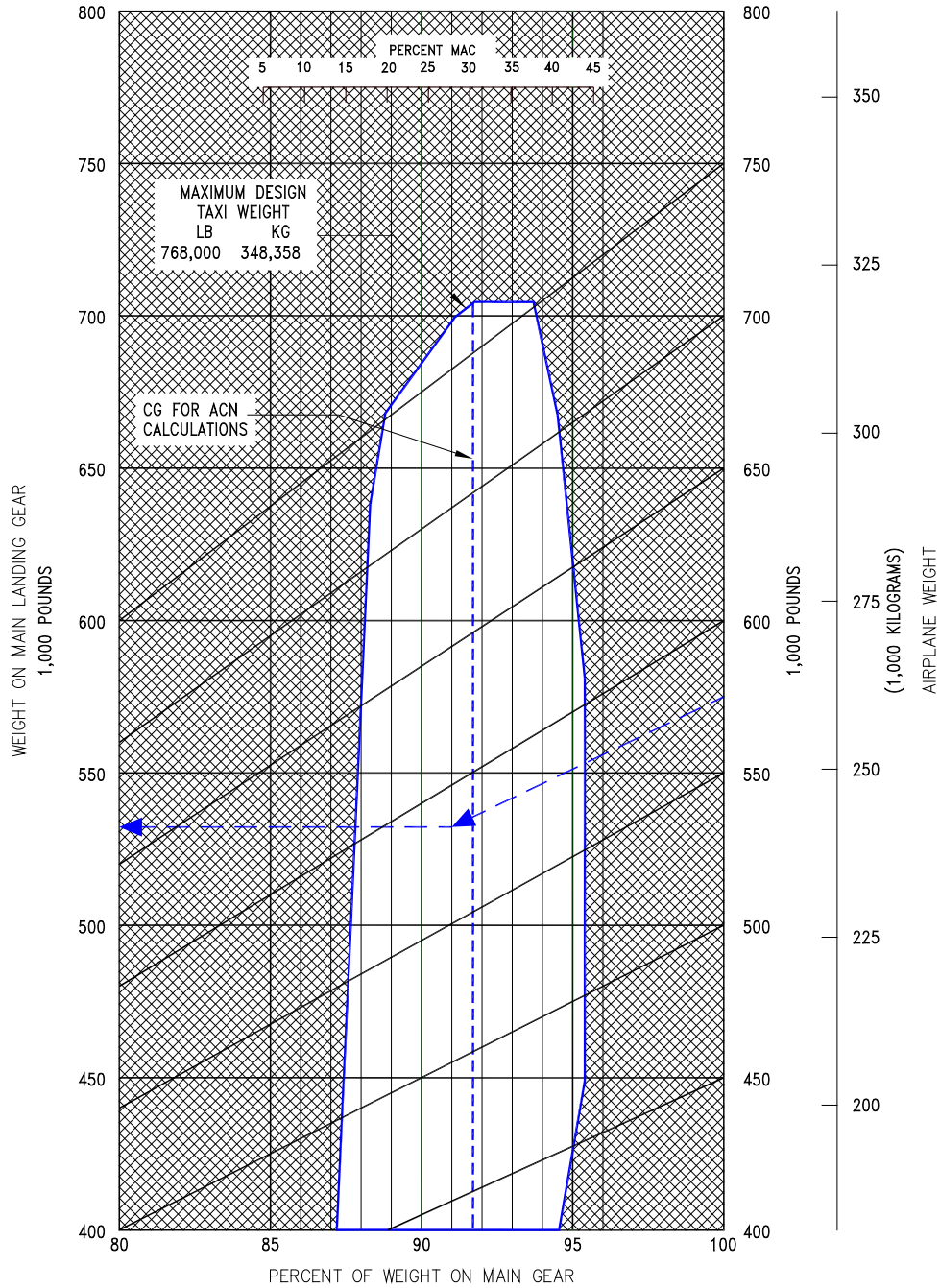

D6-58329-2

REV F

December 2022

7-7

## 7.4.2 Landing Gear Loading on Pavement: Model 777-300ER

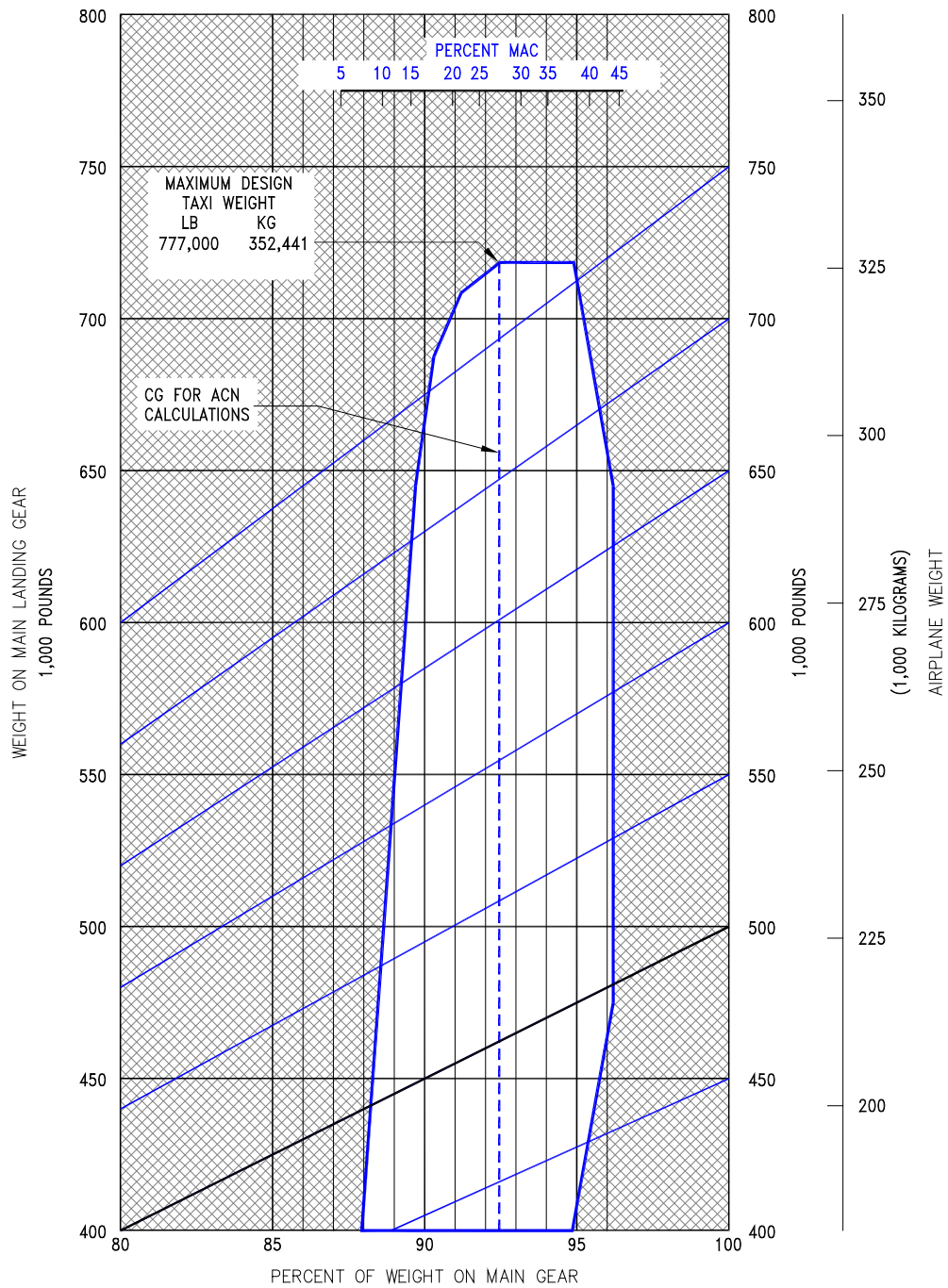

D6-58329-2



### 7.4.3 Landing Gear Loading on Pavement: Model 777F

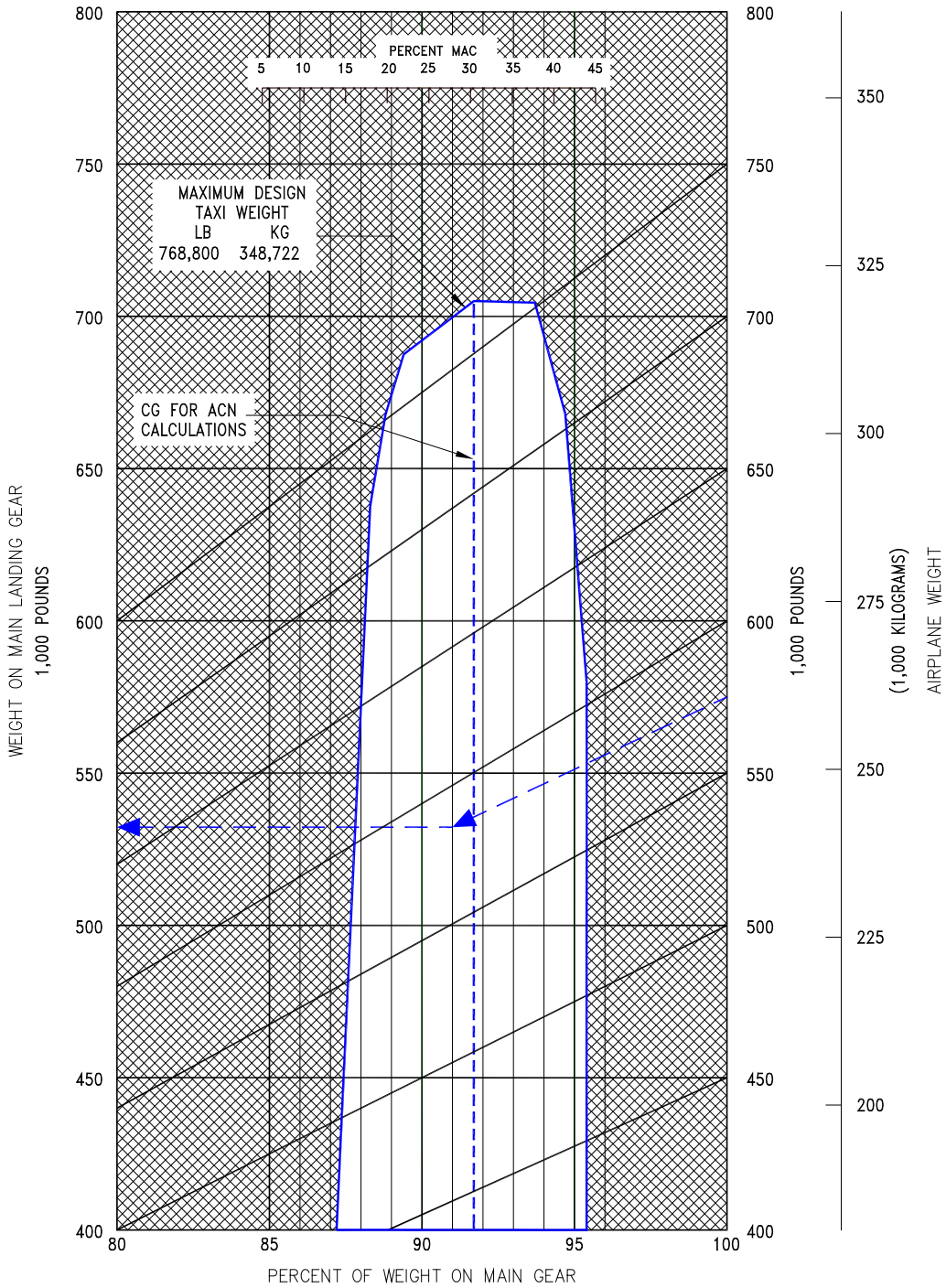

D6-58329-2

---

## 7.5 FLEXIBLE PAVEMENT REQUIREMENTS - U.S. ARMY CORPS OF ENGINEERS METHOD S-77-1

The following flexible-pavement design chart presents the data of six incremental main-gear loads at the minimum tire pressure required at the maximum design taxi weight.

In the example shown in Section 7.5.1, for a CBR of 25 and an annual departure level of 6,000, the required flexible pavement thickness for a 777-200LR airplane with a main gear loading of 550,000 pounds is 13.8 inches. Likewise, the required flexible pavement thickness for the 777-300ER under the same conditions, is 13.9 inches as shown in Section 7.5.2.

The line showing 10,000 coverages is used for ACN calculations (see Section 7.10).

**The FAA does not officially recognize the validity of the S77-1 flexible pavement design calculation for individual six-wheel gear aircraft. At the time this document (D6-58329-2) was printed, the FAA was recommending a multi-layer pavement thickness design method for the 777 airplane when considered as a component of the traffic mix. Consequently, the charts presented on the following two pages are provided as an estimate of the design thickness for general guidance purposes only.**

For the flexible pavement design refer to the FAA AC 150/5320-6 "Airport Pavement Design and Evaluation" and pavement design program FAARFIELD. Both are available on the FAA website:

FAA AC 150/5320-6: [https://www.faa.gov/airports/resources/advisory\\_circulars/](https://www.faa.gov/airports/resources/advisory_circulars/)  
FAARFIELD: [https://www.faa.gov/airports/engineering/design\\_software/](https://www.faa.gov/airports/engineering/design_software/)

# 7.5.1 Flexible Pavement Requirements - U.S. Army Corps of Engineers Design Method (S-77-1): Model 777-200LR, 777F

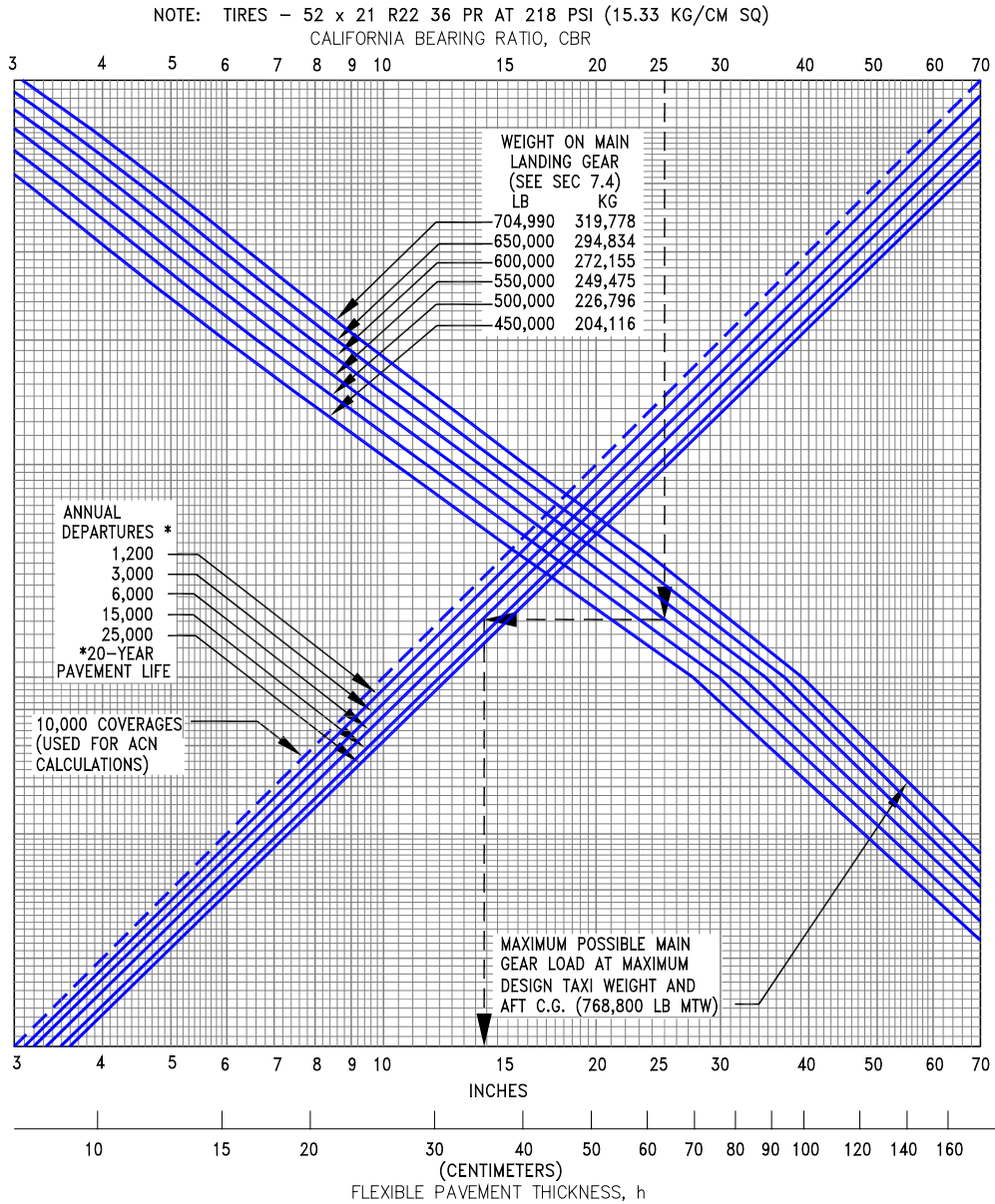

D6-58329-2

## 7.5.2 Flexible Pavement Requirements - U.S. Army Corps of Engineers Design Method (S-77-1): Model 777-300ER

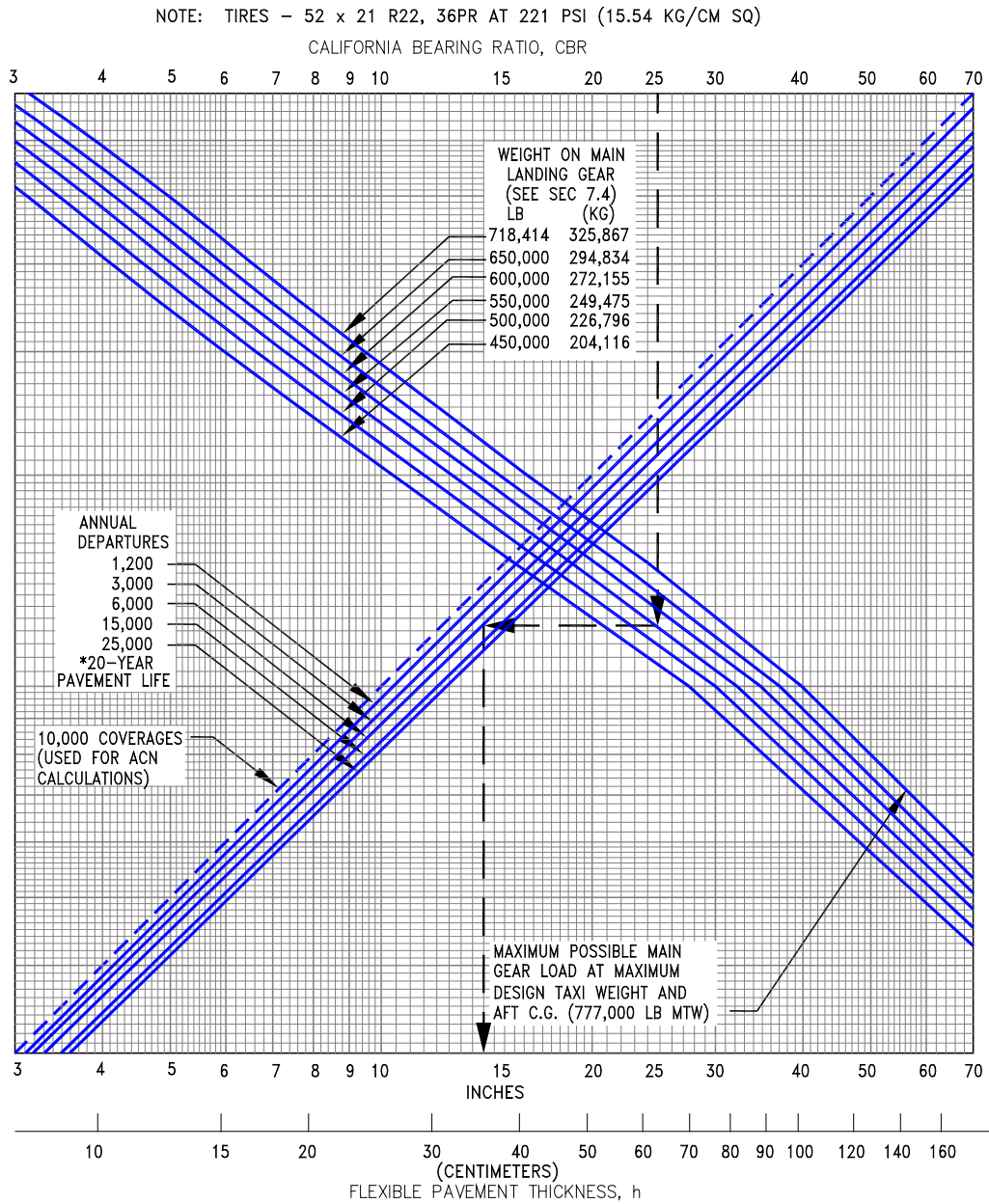

D6-58329-2

REV F

December 2022

7-12

---

## 7.6 FLEXIBLE PAVEMENT REQUIREMENTS - LCN CONVERSION

To determine the airplane weight that can be accommodated on a particular flexible pavement, both the Load Classification Number (LCN) of the pavement and the thickness must be known.

In the example shown in Section 7.6.1, flexible pavement thickness is shown at 30 inches with an LCN of 94. For these conditions, the maximum allowable weight on the main landing gear is 500,000 lb for a 777-200LR airplane with 218 psi main gear tires. Likewise, in the example shown in Section 7.6.2, the flexible pavement thickness is shown at 24 inches and the LCN is 88. For these conditions, the maximum allowable weight on the main landing gear is 550,000 lb for a 777-300ER airplane with 221 psi main gear tires.

**Note:** If the resultant aircraft LCN is not more than 10% above the published pavement LCN, the bearing strength of the pavement can be considered sufficient for unlimited use by the airplane. The figure 10% has been chosen as representing the lowest degree of variation in LCN that is significant (reference: ICAO Aerodrome Manual, Part 2, "Aerodrome Physical Characteristics," Chapter 4, Paragraph 4.1.5.7v, 2nd Edition dated 1965).

## 7.6.1 Flexible Pavement Requirements - LCN Method: Model 777-200LR, 777F

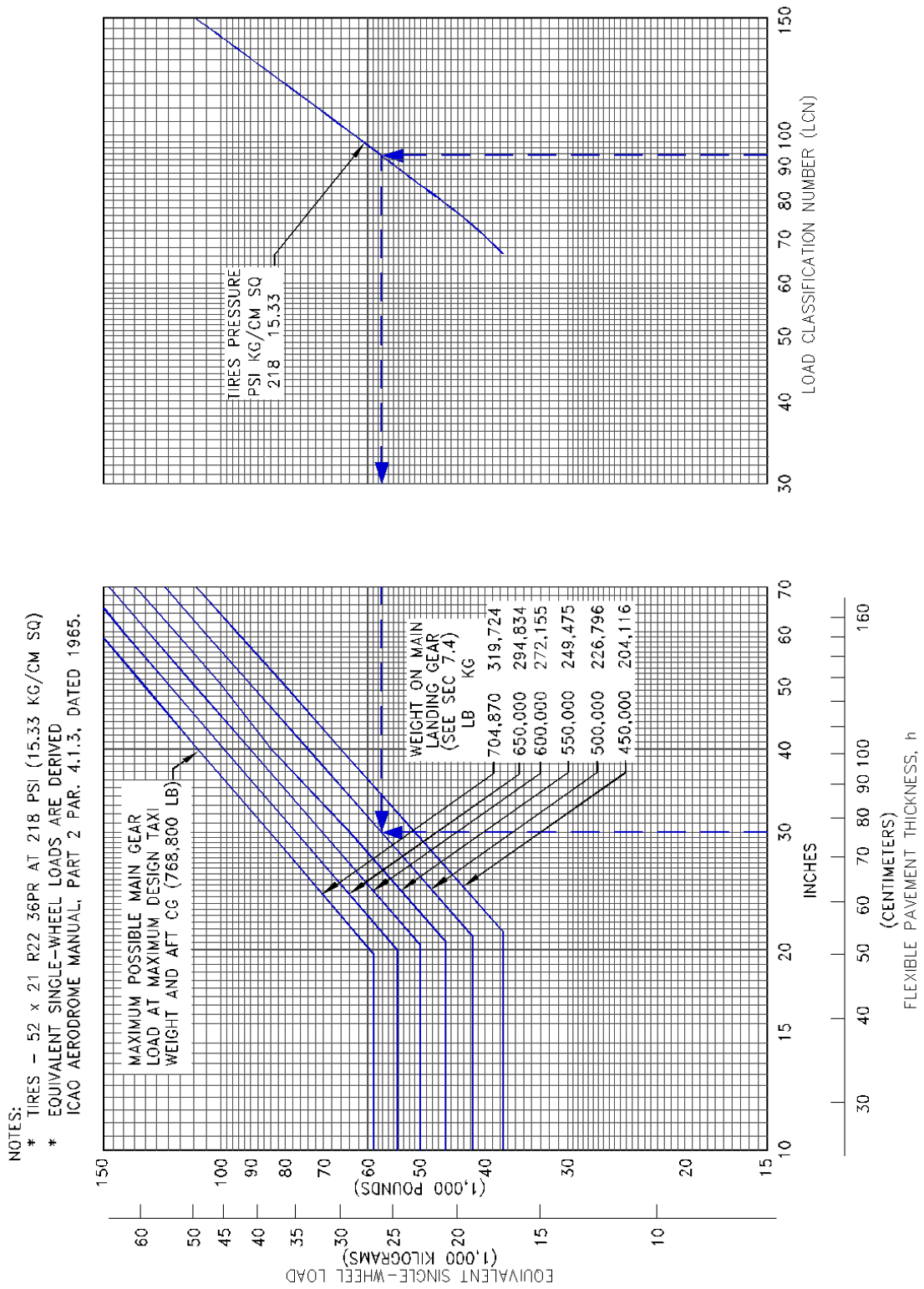

D6-58329-2

## 7.6.2 Flexible Pavement Requirements - LCN Method: Model 777-300ER

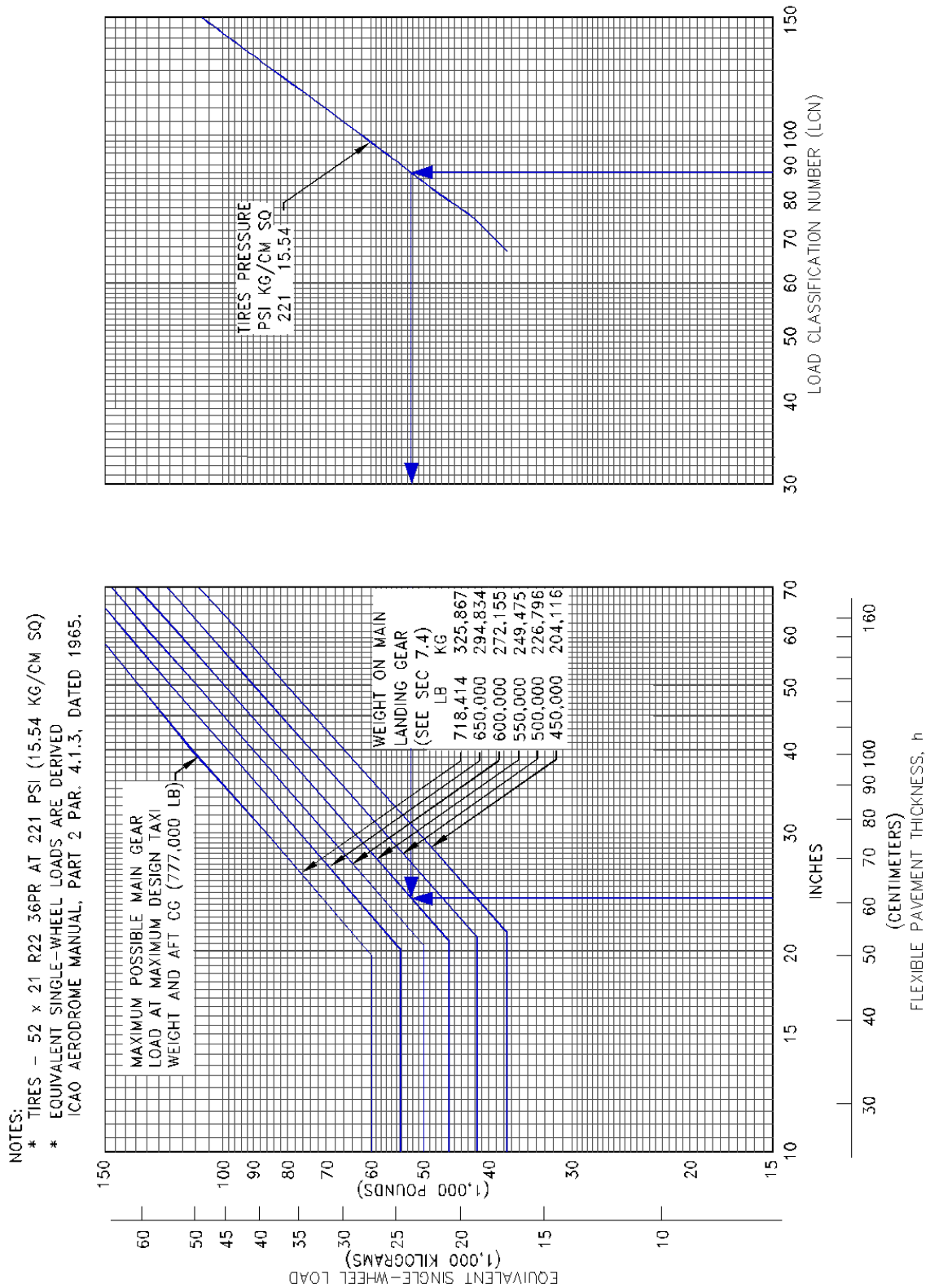

---

## 7.7 RIGID PAVEMENT REQUIREMENTS - PORTLAND CEMENT ASSOCIATION DESIGN METHOD

The Portland Cement Association method of calculating rigid pavement requirements is based on the computerized version of "Design of Concrete Airport Pavement" (Portland Cement Association, 1955) as described in XP6705-2, "Computer Program for Airport Pavement Design" by Robert G. Packard, Portland Cement Association, 1968.

The following rigid pavement design chart presents the data for six incremental main gear loads at the minimum tire pressure required at the maximum design taxi weight.

In the example shown in Section 7.7.1, for an allowable working stress of 550 psi, and a subgrade strength (k) of 300, the required rigid pavement thickness is 11.1 inches for a 777-200LR airplane with a main gear load of 650,000 lb. Likewise, for the same pavement conditions, the required pavement thickness for a 777-300ER airplane with a main gear load of 650,000 lb is 11.0 inches as shown in Section 7.7.2.



## 7.7.1 Rigid Pavement Requirements - Portland Cement Association Design Method: Model 777-200LR, 777F

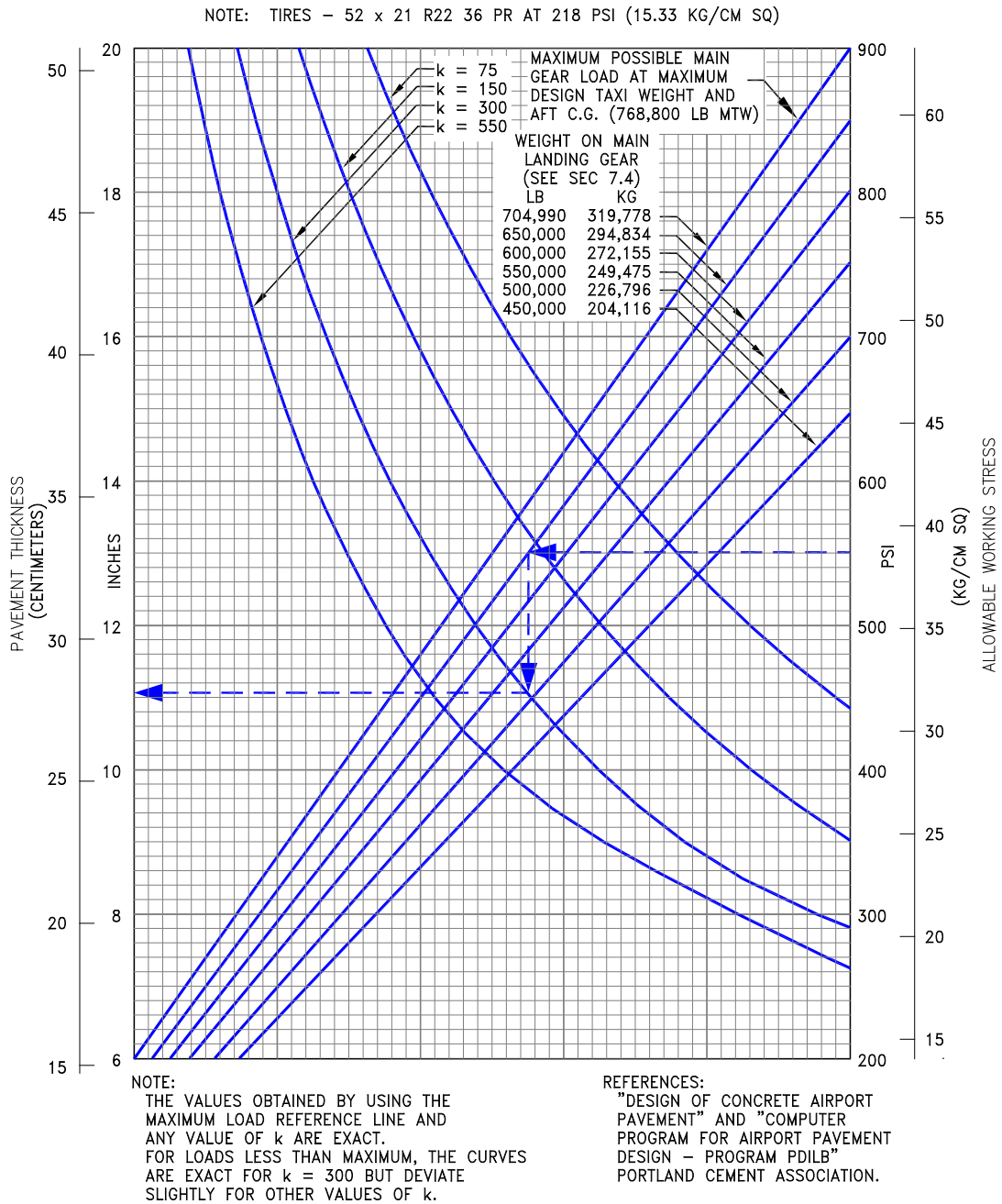

D6-58329-2

REV F

December 2022

7-17

## 7.7.2 Rigid Pavement Requirements - Portland Cement Association Design Method: Model 777-300ER

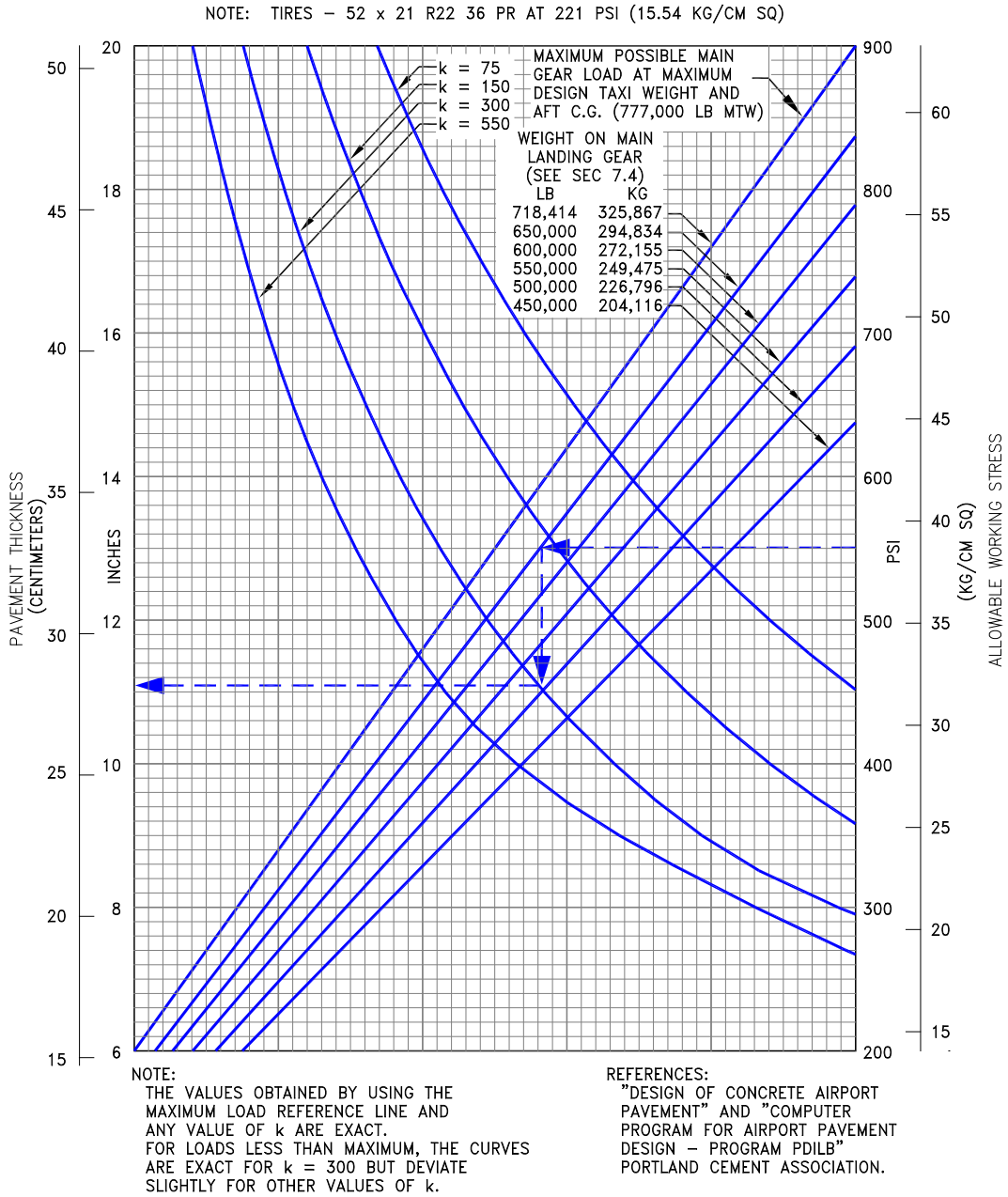

D6-58329-2

REV F

December 2022

7-18

---

## 7.8 RIGID PAVEMENT REQUIREMENTS - LCN CONVERSION

To determine the airplane weight that can be accommodated on a particular rigid pavement, both the LCN of the pavement and the radius of relative stiffness ( $k$ ) of the pavement must be known.

In the examples shown in Section 7.8.2 for a rigid pavement with a radius of relative stiffness of 47 with an LCN of 91, and 7.8.3 for a rigid pavement with a radius of relative stiffness of 47 with an LCN of 87, the apparent maximum allowable weight permissible on the main landing gear is 600,000 lb (272,155 kg) for an airplane with 221-psi (15.54 kg/cm<sup>2</sup>) main tires.

**Note:** If the resultant aircraft LCN is not more than 10% above the published pavement LCN, the bearing strength of the pavement can be considered sufficient for unlimited use by the airplane. The figure 10% has been chosen as representing the lowest degree of variation in LCN that is significant (reference: ICAO Aerodrome Design Manual, Part 2, "Aerodrome Physical Characteristics," Chapter 4, Paragraph 4.1.5.7v, 2nd Edition dated 1965).

## 7.8.1 Radius of Relative Stiffness (Reference: Portland Cement Association)

RADIUS OF RELATIVE STIFFNESS ( $l$ )

VALUES IN INCHES

$$l = \sqrt[4]{\frac{Ed^3}{12(1-\mu^2)k}} = 24.1652 \sqrt[4]{\frac{d^3}{k}}$$

WHERE: E = YOUNG'S MODULUS OF ELASTICITY =  $4 \times 10^6$  psi

k = SUBGRADE MODULUS, LB PER CU IN

d = RIGID PAVEMENT THICKNESS, IN

$\mu$  = POISSON'S RATIO = 0.15

d	k = 75	k = 100	k = 150	k = 200	k = 250	k = 300	k = 350	k = 400	k = 500	k = 550
6.0	31.48	29.29	26.47	24.63	23.30	22.26	21.42	20.71	19.59	19.13
6.5	33.42	31.10	28.11	26.16	24.74	23.63	22.74	21.99	20.80	20.31
7.0	35.33	32.88	29.71	27.65	26.15	24.99	24.04	23.25	21.99	21.47
7.5	37.21	34.63	31.29	29.12	27.54	26.31	25.32	24.49	23.16	22.61
8.0	39.06	36.35	32.84	30.56	28.91	27.62	26.57	25.70	24.31	23.73
8.5	40.87	38.04	34.37	31.99	30.25	28.90	27.81	26.90	25.44	24.84
9.0	42.66	39.70	35.88	33.39	31.57	30.17	29.03	28.07	26.55	25.93
9.5	44.43	41.35	37.36	34.77	32.88	31.42	30.23	29.24	27.65	27.00
10.0	46.17	42.97	38.83	36.13	34.17	32.65	31.41	30.38	28.73	28.06
10.5	47.89	44.57	40.27	37.48	35.44	33.87	32.58	31.52	29.81	29.10
11.0	49.59	46.15	41.70	38.81	36.70	35.07	33.74	32.63	30.86	30.14
11.5	51.27	47.72	43.12	40.12	37.95	36.26	34.89	33.74	31.91	31.16
12.0	52.94	49.26	44.51	41.43	39.18	37.43	36.02	34.83	32.94	32.17
12.5	54.58	50.80	45.90	42.71	40.40	38.60	37.14	35.92	33.97	33.17
13.0	56.21	52.31	47.27	43.99	41.60	39.75	38.25	36.99	34.98	34.16
13.5	57.83	53.81	48.63	45.25	42.80	40.89	39.34	38.05	35.99	35.14
14.0	59.43	55.30	49.97	46.50	43.98	42.02	40.43	39.10	36.98	36.11
14.5	61.01	56.78	51.30	47.74	45.15	43.14	41.51	40.15	37.97	37.07
15.0	62.58	58.24	52.62	48.97	46.32	44.25	42.58	41.18	38.95	38.03
15.5	64.14	59.69	53.93	50.19	47.47	45.35	43.64	42.21	39.92	38.98
16.0	65.69	61.13	55.23	51.40	48.61	46.45	44.69	43.22	40.88	39.92
16.5	67.22	62.55	56.52	52.60	49.75	47.53	45.73	44.23	41.83	40.85
17.0	68.74	63.97	57.80	53.79	50.87	48.61	46.77	45.23	42.78	41.77
17.5	70.25	65.38	59.07	54.97	51.99	49.68	47.80	46.23	43.72	42.69
18.0	71.75	66.77	60.34	56.15	53.10	50.74	48.82	47.22	44.65	43.60
19.0	74.72	69.54	62.83	58.47	55.30	52.84	50.84	49.17	46.50	45.41
20.0	77.65	72.26	65.30	60.77	57.47	54.91	52.83	51.10	48.33	47.19
21.0	80.55	74.96	67.73	63.03	59.61	56.95	54.80	53.00	50.13	48.95
22.0	83.41	77.62	70.14	65.27	61.73	58.98	56.75	54.88	51.91	50.68
23.0	86.23	80.25	72.51	67.48	63.82	60.98	58.67	56.74	53.67	52.40
24.0	89.03	82.85	74.86	69.67	65.89	62.95	60.57	58.58	55.41	54.10
25.0	91.80	85.43	77.19	71.84	67.94	64.91	62.46	60.41	57.13	55.78

## 7.8.2 Rigid Pavement Requirements - LCN Conversion: Model 777-200LR, 777F

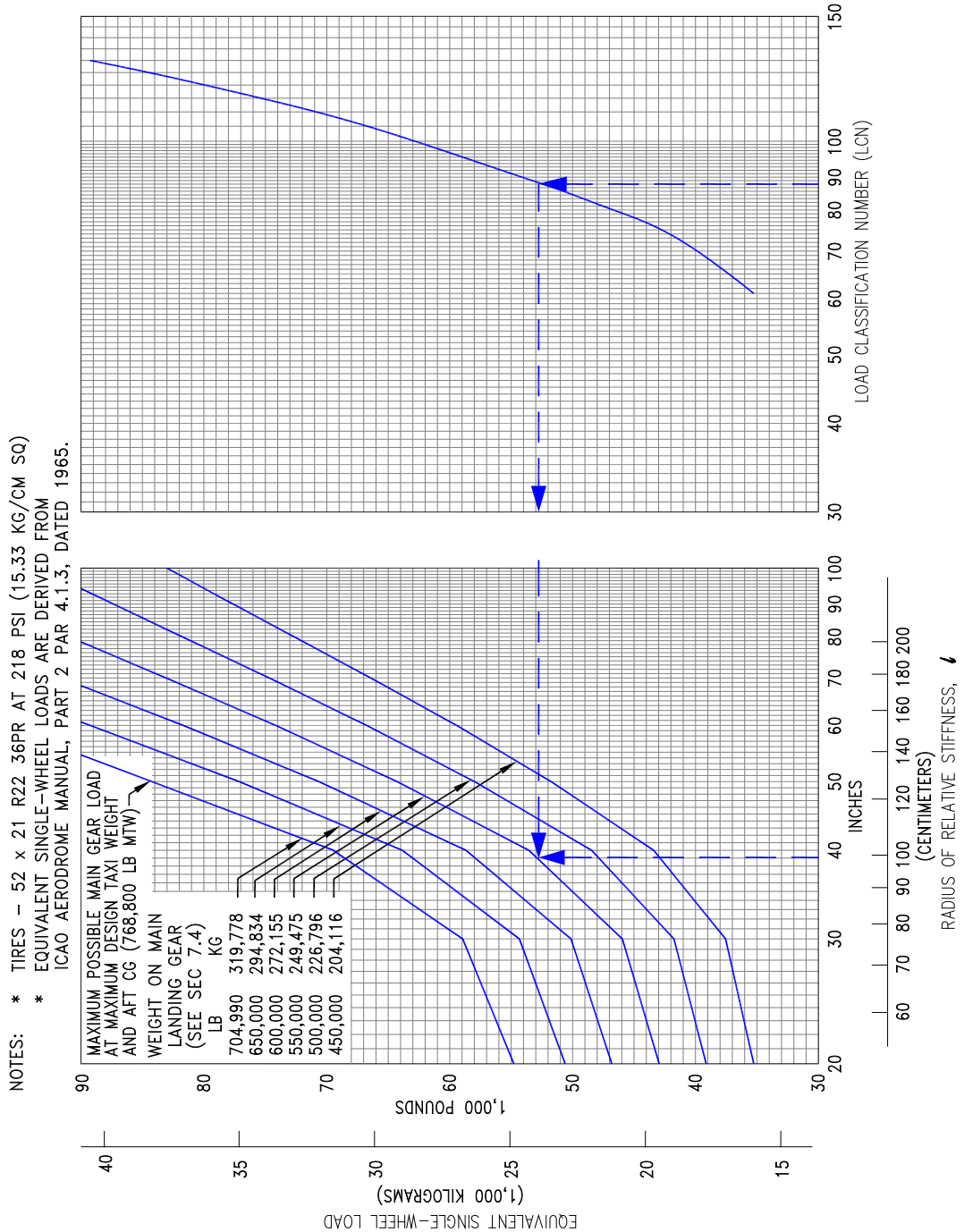

D6-58329-2

December 2022

REV F

7-21

### 7.8.3 Rigid Pavement Requirements - LCN Conversion: Model 777-300ER

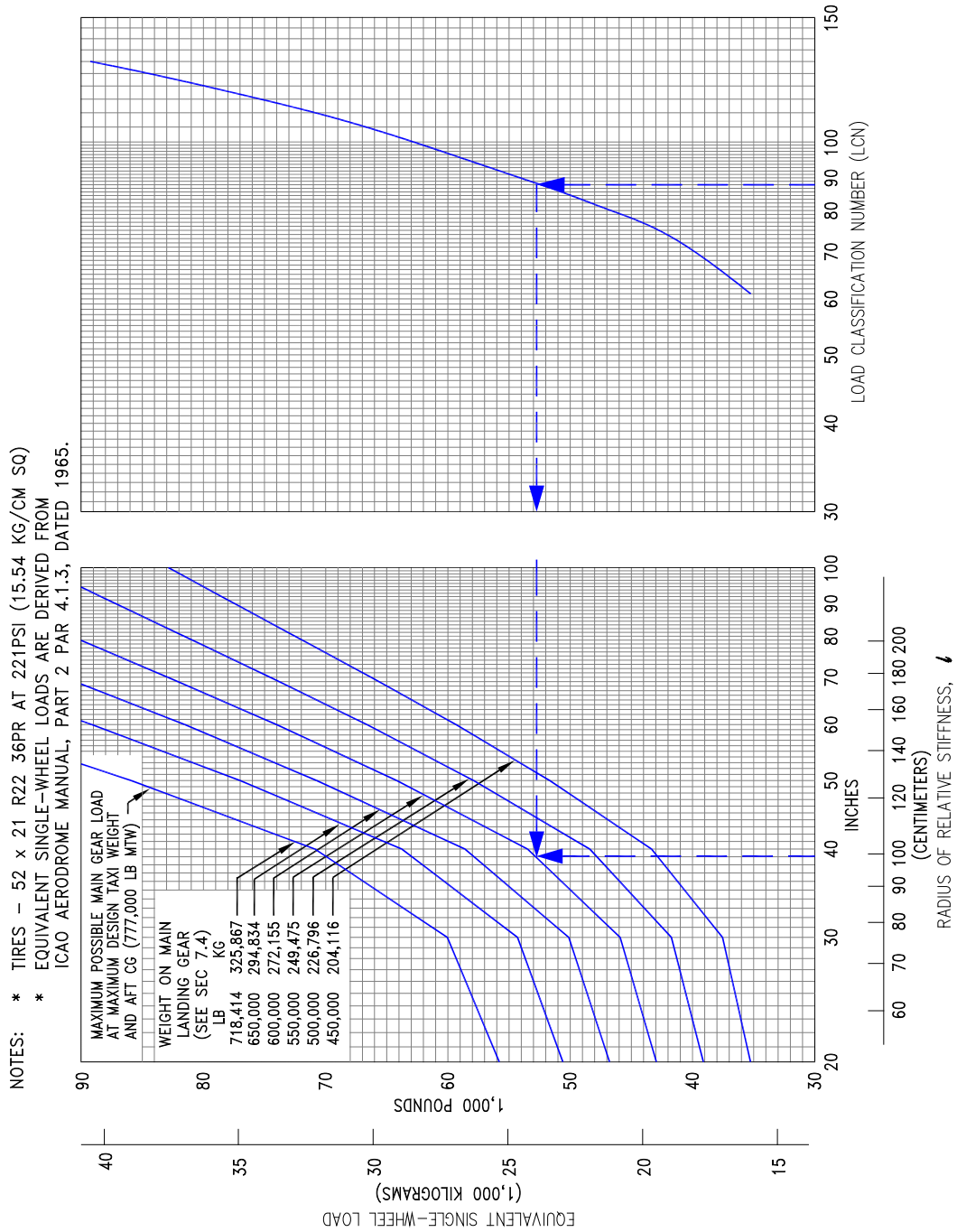

---

## 7.9 RIGID PAVEMENT REQUIREMENTS - FAA DESIGN METHOD

The following rigid-pavement design chart presents data on six incremental main gear loads at the minimum tire pressure required at the maximum design taxi weight.

In the example shown, for a pavement flexural strength of 700 psi, a subgrade strength of  $k = 300$ , and an annual departure level of 3,000, the required pavement thickness for a 777-200LR or 777-300ER airplane with a main gear load of 650,00 lb is 10.8 inches.

**The FAA does not officially recognize the validity of rigid pavement thickness design calculations for individual six-wheel gear aircraft. At the time this document (D6-58329-2) was printed, the FAA was recommending a multi-layer pavement thickness design method for the 777 airplane when considered as a component of the traffic mix. Consequently, the chart presented in Section 7.9.1 is provided as an estimate of the design thickness for general guidance purposes only.**

For the rigid pavement design refer to the FAA AC 150/5320-6 “Airport Pavement Design and Evaluation” and pavement design program FAARFIELD. Both are available on the FAA website:

FAA AC 150/5320-6: [https://www.faa.gov/airports/resources/advisory\\_circulars/](https://www.faa.gov/airports/resources/advisory_circulars/)  
FAARFIELD: [https://www.faa.gov/airports/engineering/design\\_software/](https://www.faa.gov/airports/engineering/design_software/)

## 7.9.1 Rigid Pavement Requirements: Model 777-200LR, -300ER, 777F

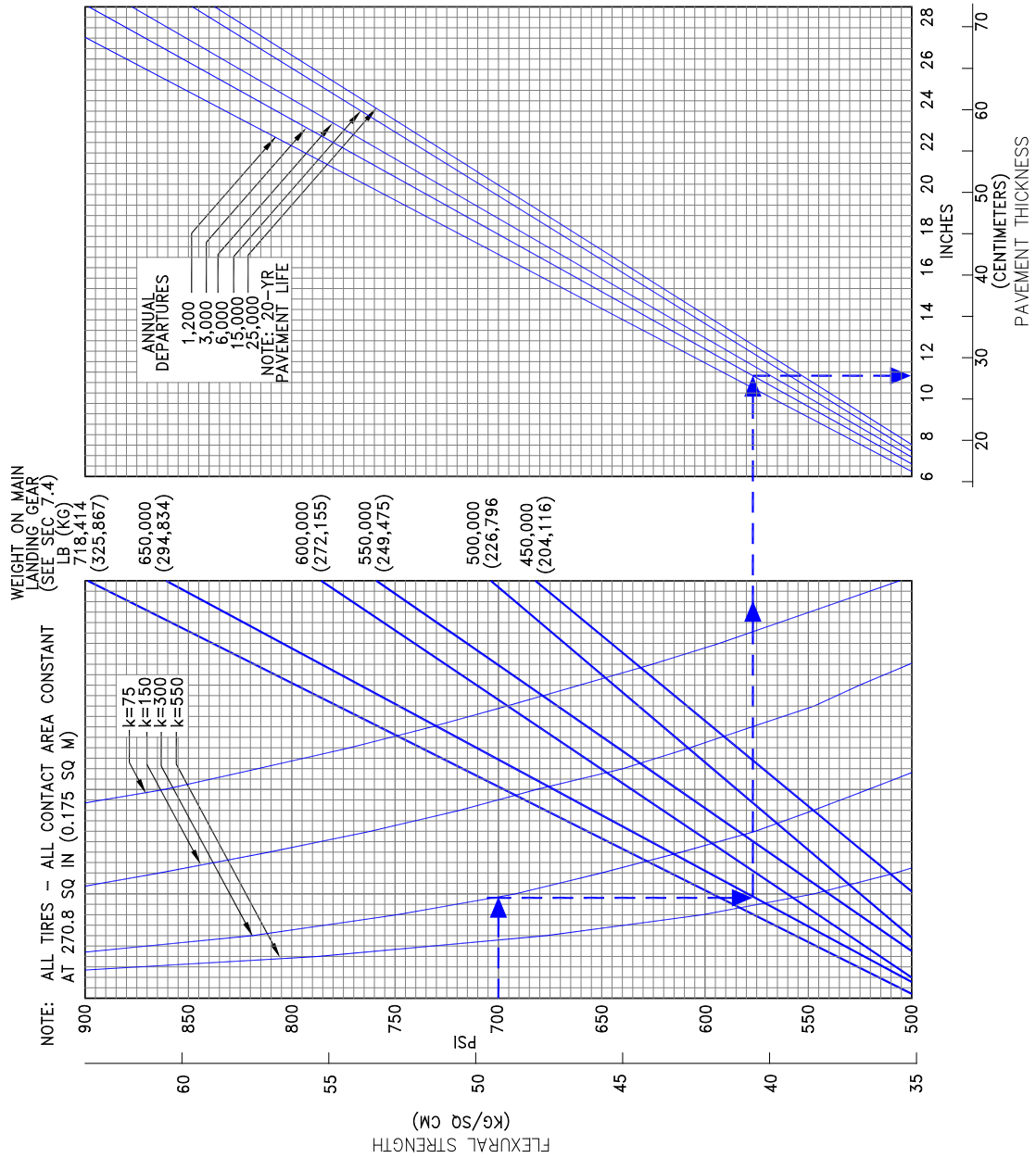

D6-58329-2



## 7.10 ACN/PCN REPORTING SYSTEM - FLEXIBLE AND RIGID PAVEMENTS

To determine the ACN of an aircraft on flexible or rigid pavement, both the aircraft gross weight and the subgrade strength category must be known. The chart in Section 7.10.1 shows that for a 777F aircraft with gross weight of 700,000 lb on a medium strength subgrade (Code B), the flexible pavement ACN is 60. In Section 7.10.4, for the same aircraft weight and medium subgrade strength (Code B), the rigid pavement ACN is 70.

The following table provides ACN data in tabular format similar to the one used by ICAO in the “Aerodrome Design Manual Part 3, Pavements.” If the ACN for an intermediate weight between taxi weight and empty fuel weight of the aircraft is required, Figures 7.10.1 through 7.10.6 should be consulted.

AIRCRAFT TYPE	MAXIMUM TAXI WEIGHT MINIMUM WEIGHT (1) LB (KG)	LOAD ON ONE MAIN GEAR LEG (%)	TIRE PRESSURE PSI (MPa)	ACN FOR RIGID PAVEMENT SUBGRADES –pci (MN/m <sup>3</sup> )				ACN FOR FLEXIBLE PAVEMENT SUBGRADES –CBR			
				HIGH 550 (150)	MEDIUM 300 (80)	LOW 150 (40)	ULTRA LOW 75 (20)	HIGH 15	MEDIUM 10	LOW 6	ULTRA LOW 3
777F	768,800(348,722)	45.85	218 (1.50)	64	83	106	128	62	69	87	117
	318,300(144,242)			21	23	27	34	19	21	23	31
777-200LR	768,000(348,358)	45.89	218 (1.50)	64	83	106	128	62	69	87	117
	320,000(145,150)			21	23	28	34	20	21	24	31
777-300ER	777,000(352,441)	46.23	221 (1.52)	66	86	110	132	64	71	89	120
	370,000(167,829)			25	28	35	43	24	25	29	40

(1) Minimum weight used solely as a baseline for ACN curve generation.

## 7.10.1 Aircraft Classification Number - Flexible Pavement: Model 777F

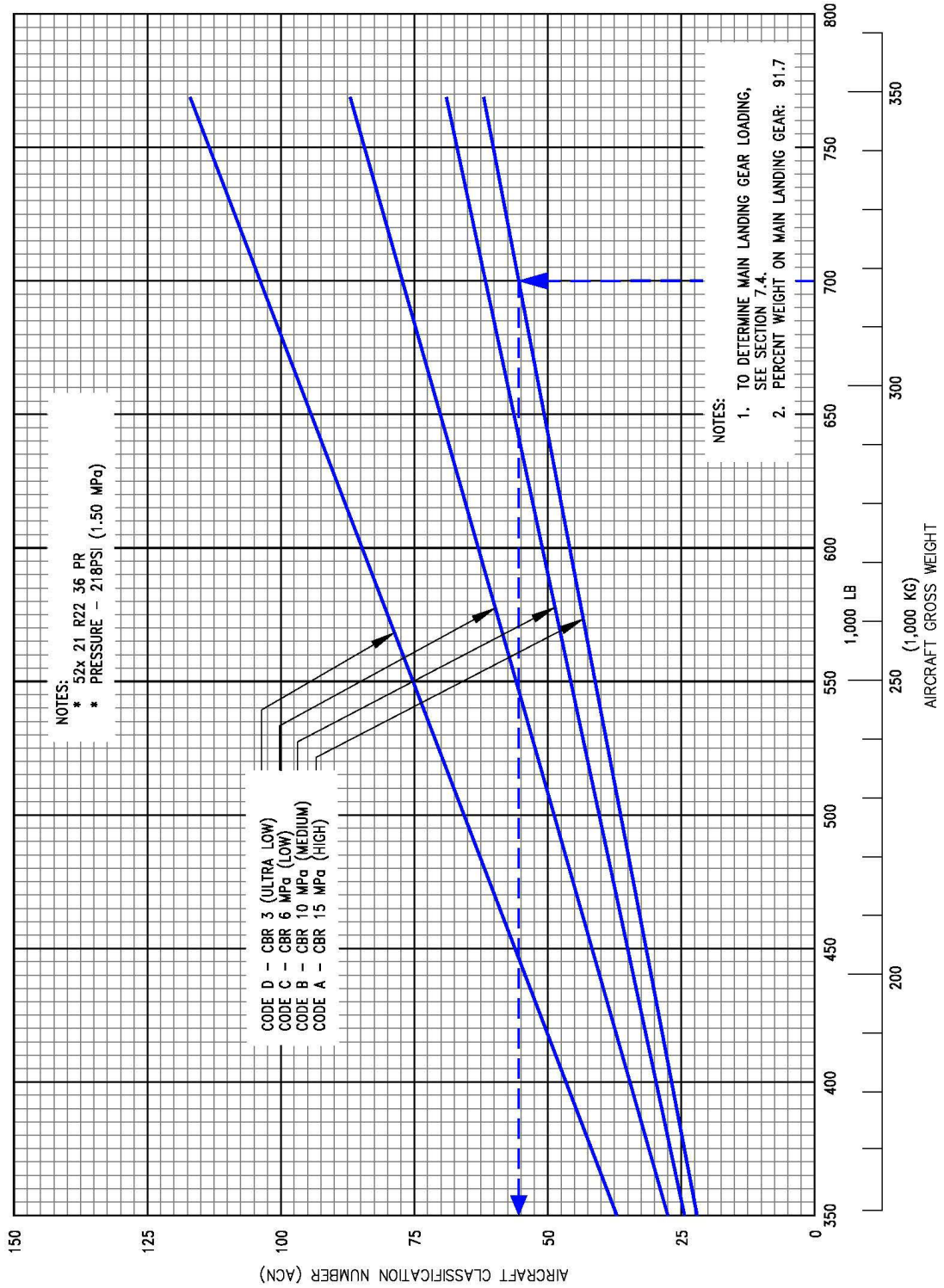

D6-58329-2

REV F

December 2022

7-26

## 7.10.2 Aircraft Classification Number - Flexible Pavement: Model 777-200LR

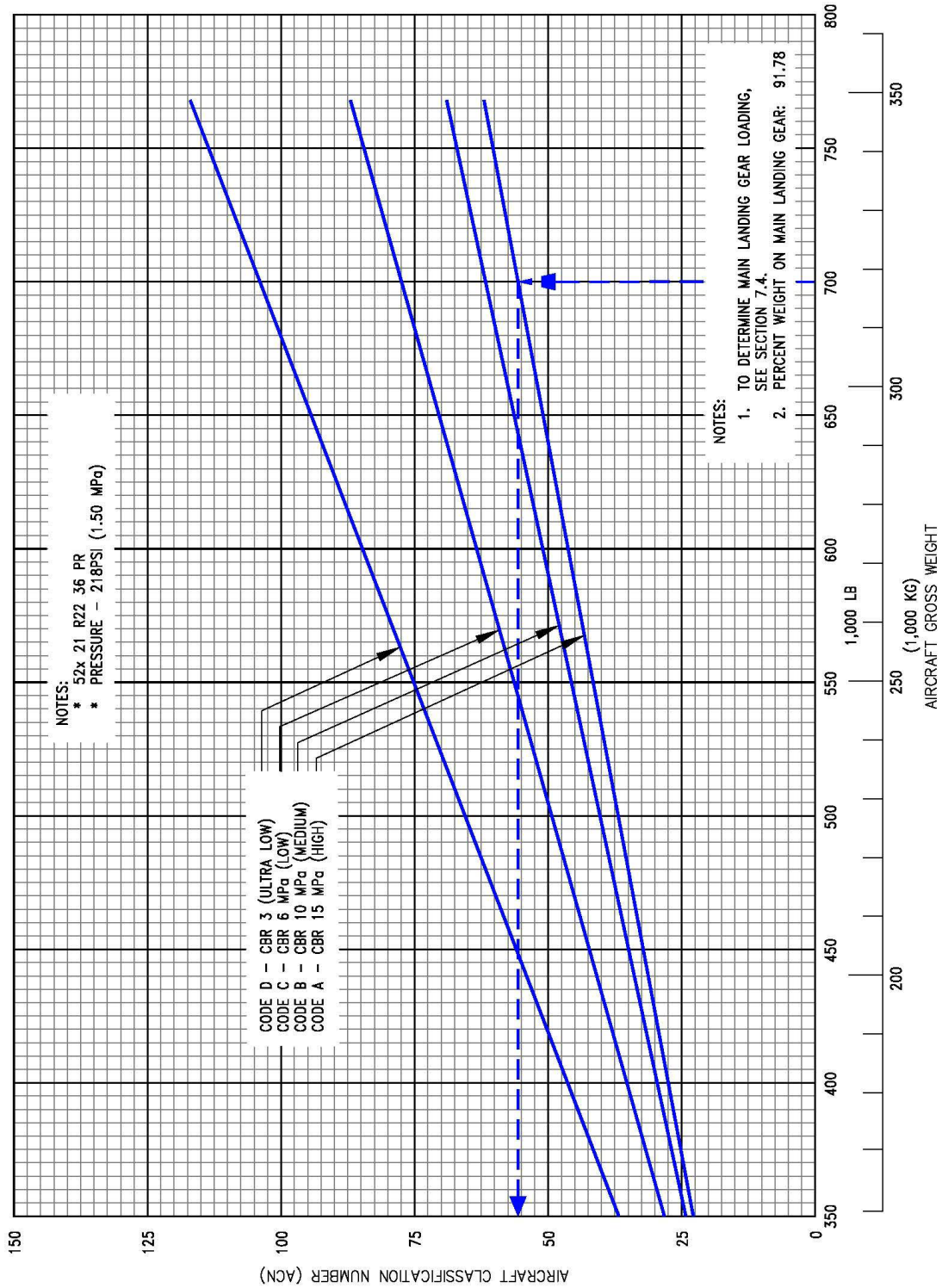

D6-58329-2

REV F

December 2022

7-27

### 7.10.3 Aircraft Classification Number - Flexible Pavement: Model 777-300ER

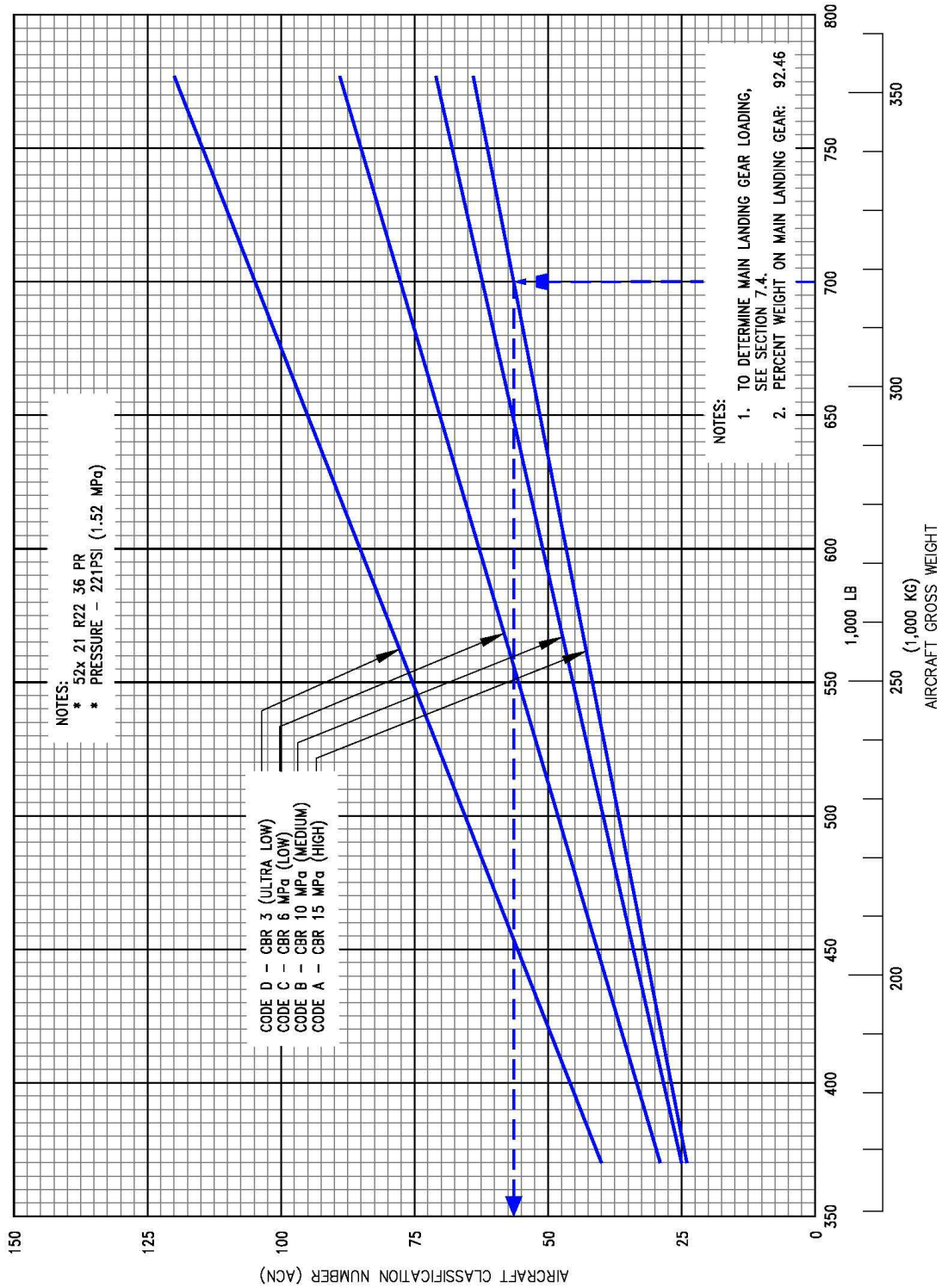

D6-58329-2

## 7.10.4 Aircraft Classification Number - Rigid Pavement: Model 777F

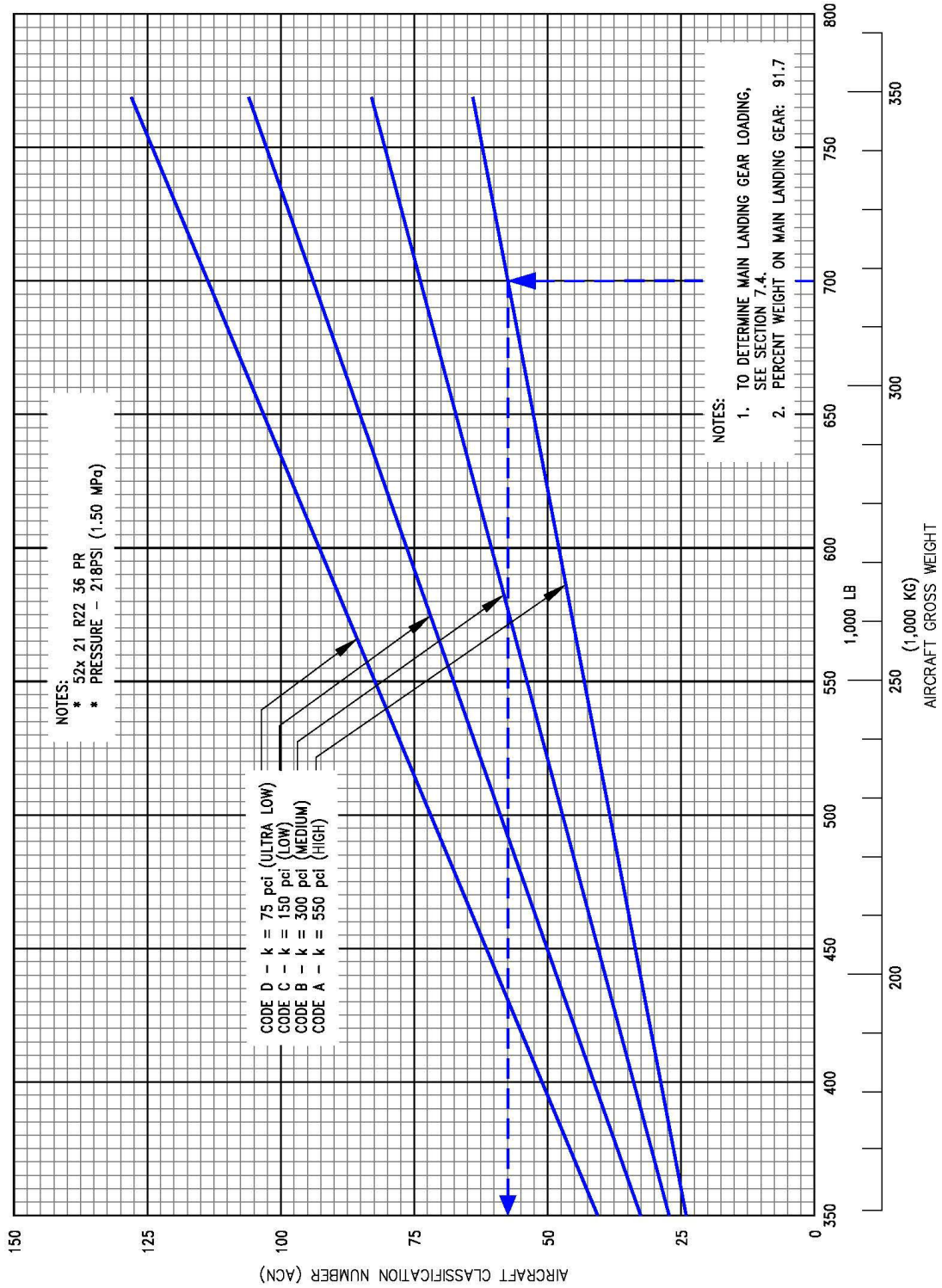

D6-58329-2

REV F

December 2022

7-29



## 7.10.5 Aircraft Classification Number - Rigid Pavement: Model 777-200LR

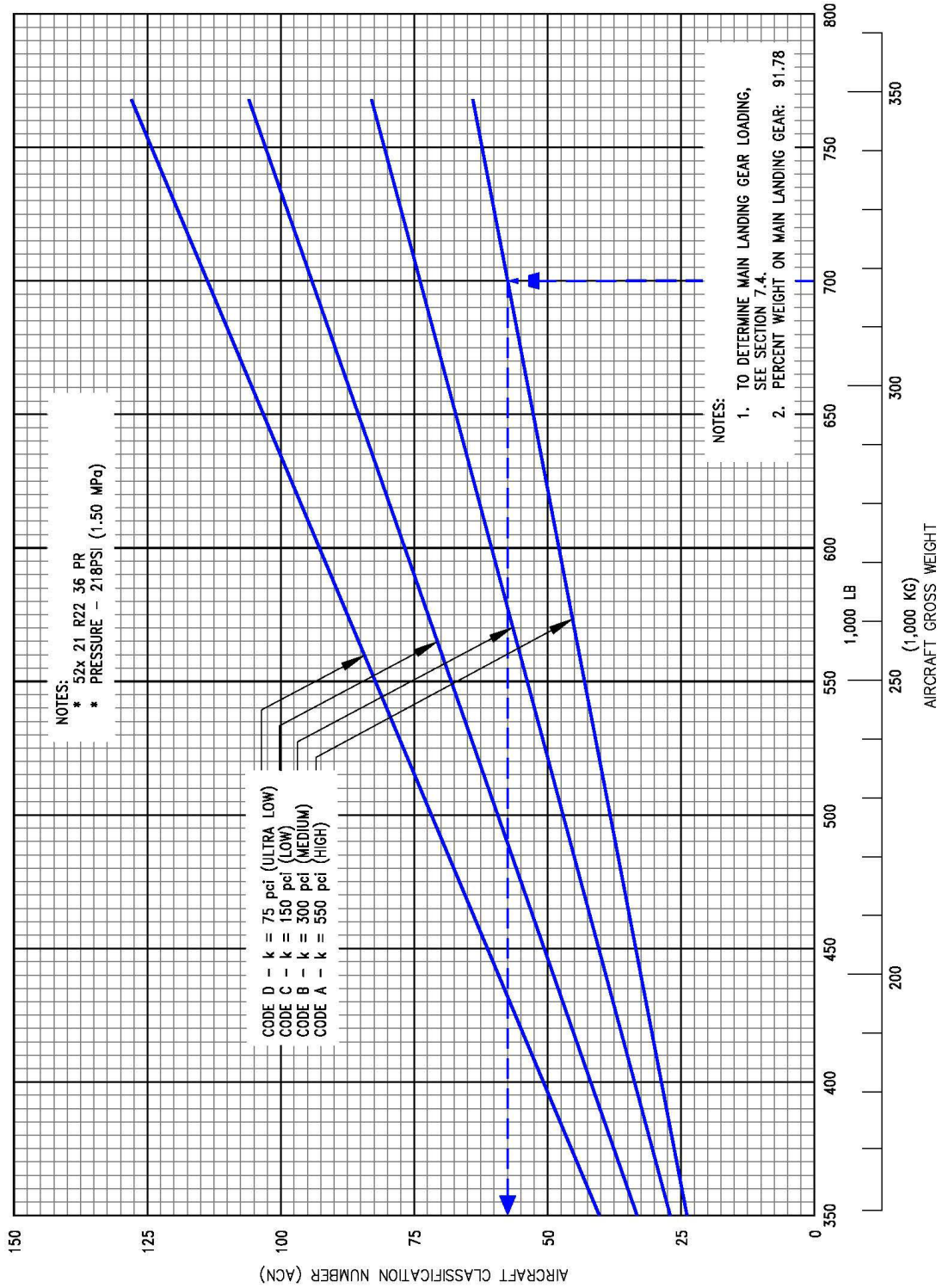

D6-58329-2

REV F

December 2022

7-30

## 7.10.6 Aircraft Classification Number - Rigid Pavement: Model 777-300ER

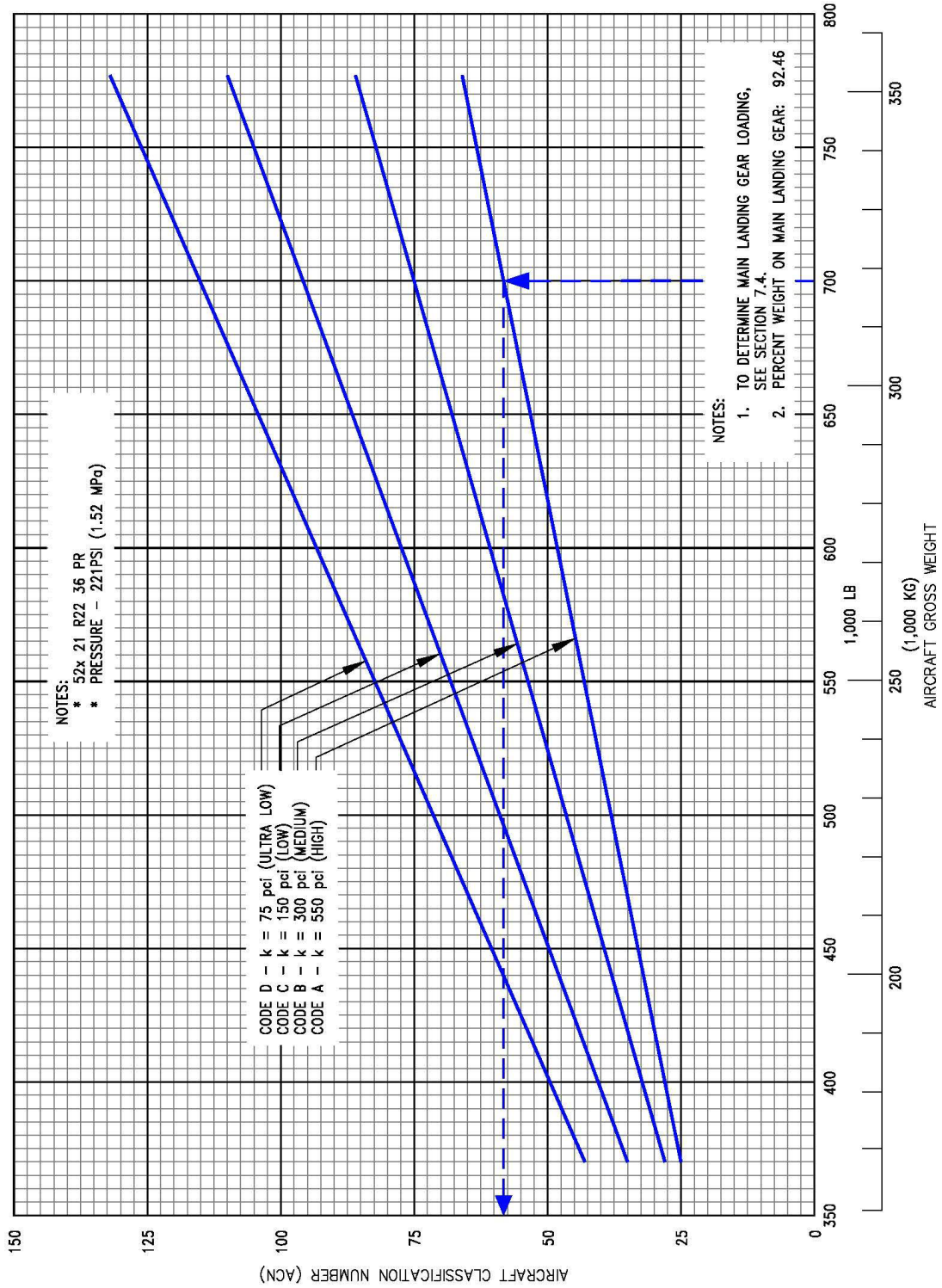

D6-58329-2

REV F

December 2022

7-31

## 7.11 ACR/PCR REPORTING SYSTEM - FLEXIBLE AND RIGID PAVEMENTS

To determine the ACR of an aircraft on flexible or rigid pavement, both the aircraft gross weight and the subgrade strength category must be known. In the chart in Section 7.11.1, for a 777 Freighter aircraft with gross weight of 700,000 lb on a Code A, the flexible pavement ACR is 510. In Section 7.11.4, the same aircraft on a high strength subgrade rigid pavement has an ACR of 645.

The following table provides ACR data in tabular format. If the ACR for an intermediate weight between maximum taxi weight and the empty weight of the aircraft is required, Figures 7.11.1 through 7.11.6 should be consulted.

AIRCRAFT TYPE	MAXIMUM TAXI WEIGHT ----- MINIMUM WEIGHT *[1] lb (kg)	LOAD ON ONE MAIN GEAR LEG (%)	TIRE PRESSURE psi (MPa)	ACR FOR RIGID PAVEMENT SUBGRADES				ACR FOR FLEXIBLE PAVEMENT SUBGRADES			
				HIGH E = 200 MPa	MEDIUM E = 120 MPa	LOW E = 80 MPa	ULTRA LOW E = 50 MPa	HIGH E = 200 MPa	MEDIUM E = 120 MPa	LOW E = 80 MPa	ULTRA LOW E = 50 MPa
777F	768,800 (348,722)	45.85	218 (1.50)	758	972	1141	1320	563	613	760	1185
	318,300 (144,378)			216	238	270	325	231	230	236	257
777-200LR	768,000 (348,359)	45.89	218 (1.50)	758	972	1141	1320	563	613	759	1185
	320,000(145,150)			218	240	273	328	232	232	237	259
777-300ER	777,000 (352,441)	46.23	221 (1.52)	787	1006	1178	1360	577	629	787	1232
	370,000 (167,829)			261	298	347	421	271	272	282	319

\*[1] Minimum weight used solely as a baseline for ACN curve generation.



# 7.11.1 Aircraft Classification Rating - Flexible Pavement: Model 777F

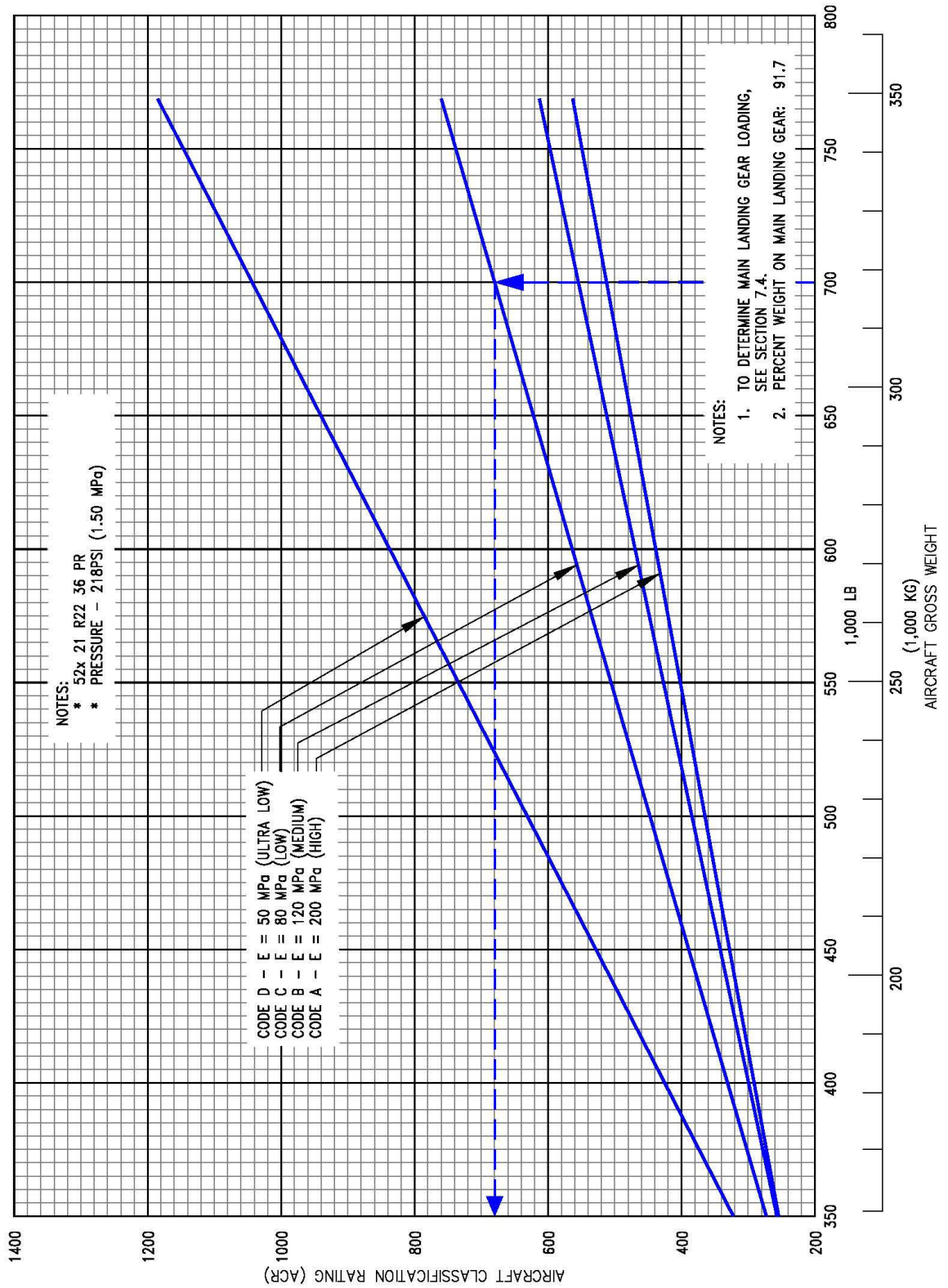

D6-58329-2

## 7.11.2 Aircraft Classification Rating - Flexible Pavement: Model 777-200LR

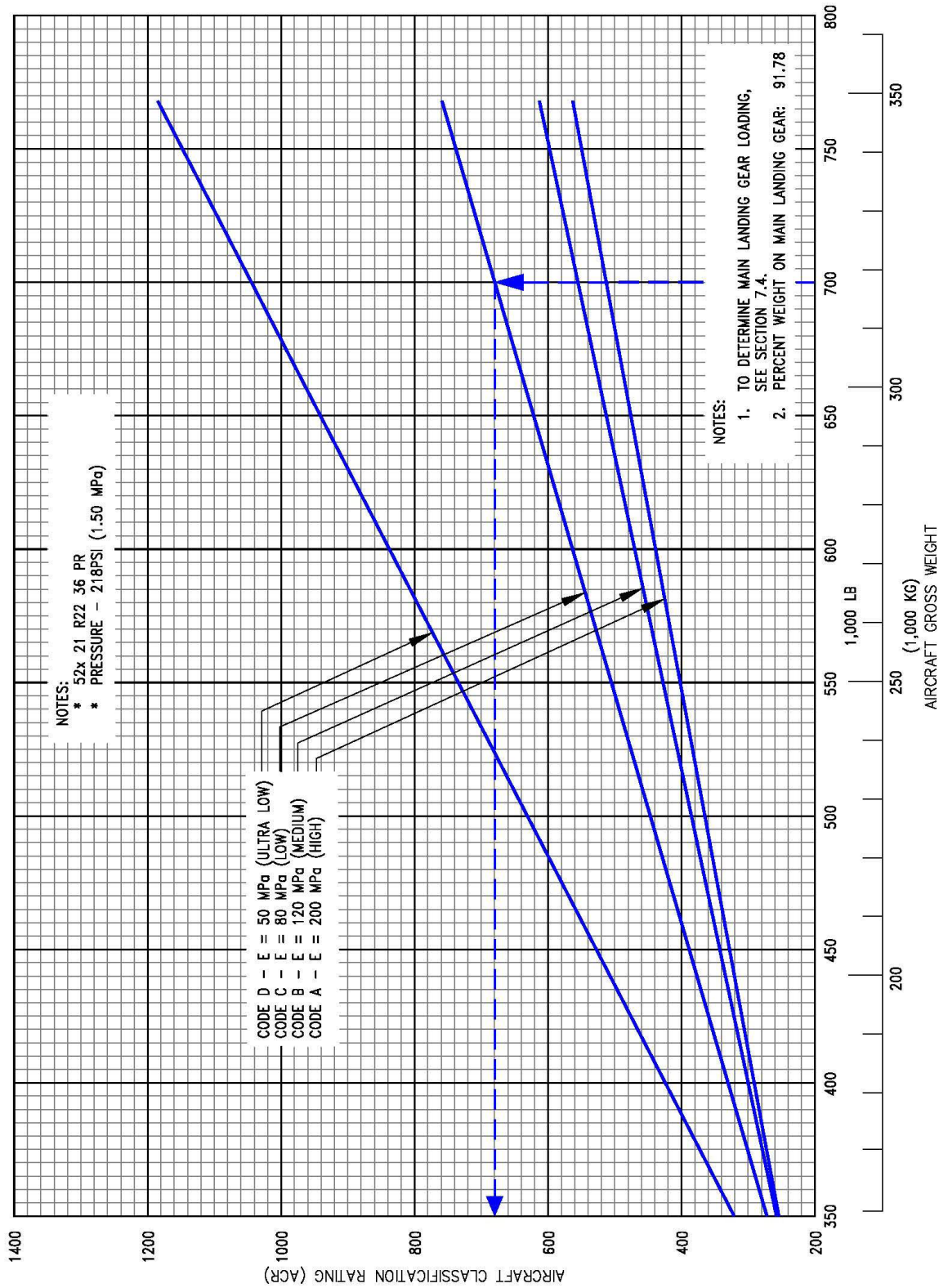

D6-58329-2

REV F

December 2022

7-34

### 7.11.3 Aircraft Classification Rating - Flexible Pavement: Model 777-300ER

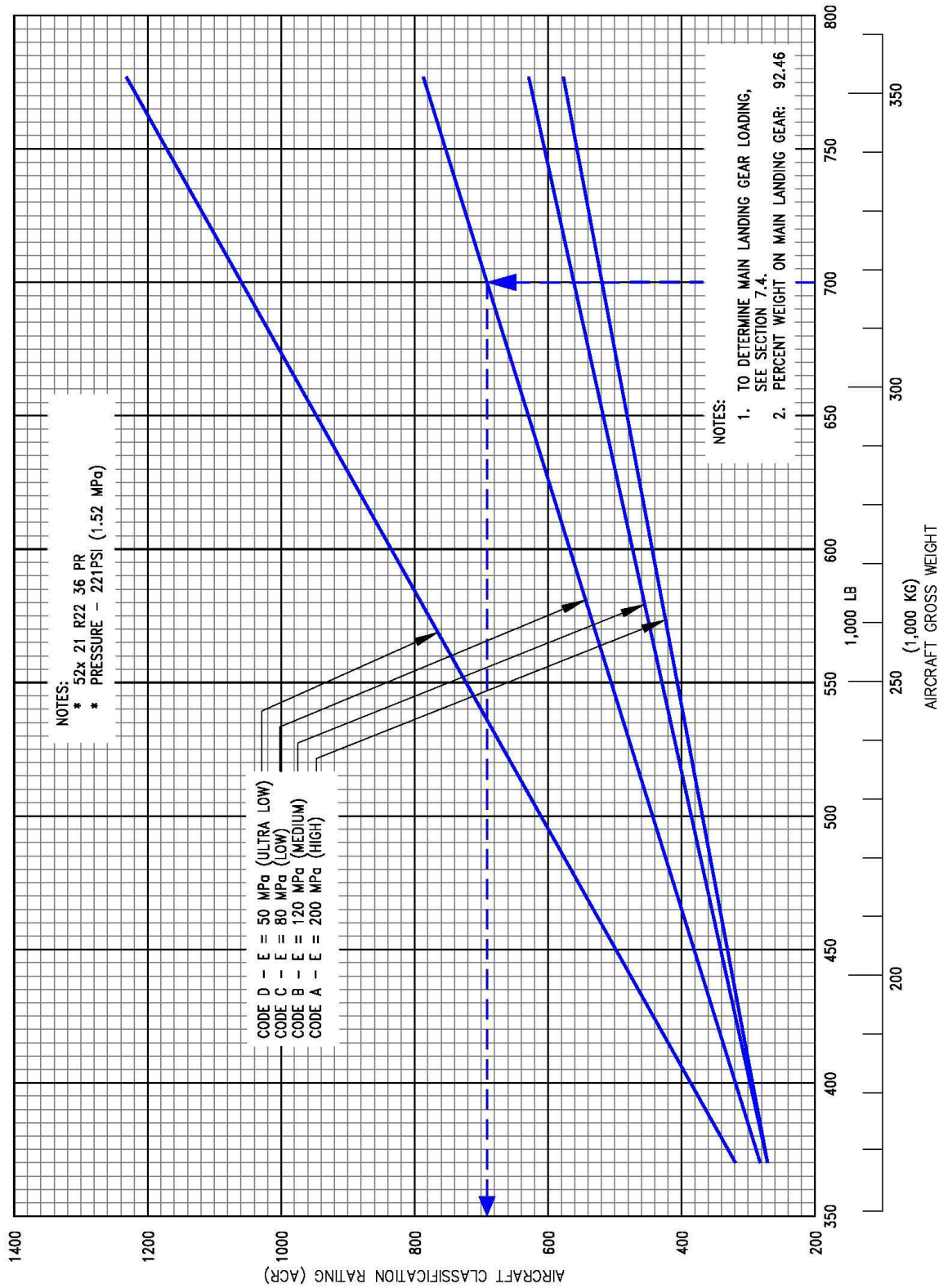

D6-58329-2

REV F

December 2022

7-35



### 7.11.4 Aircraft Classification Rating - Rigid Pavement: Model 777F

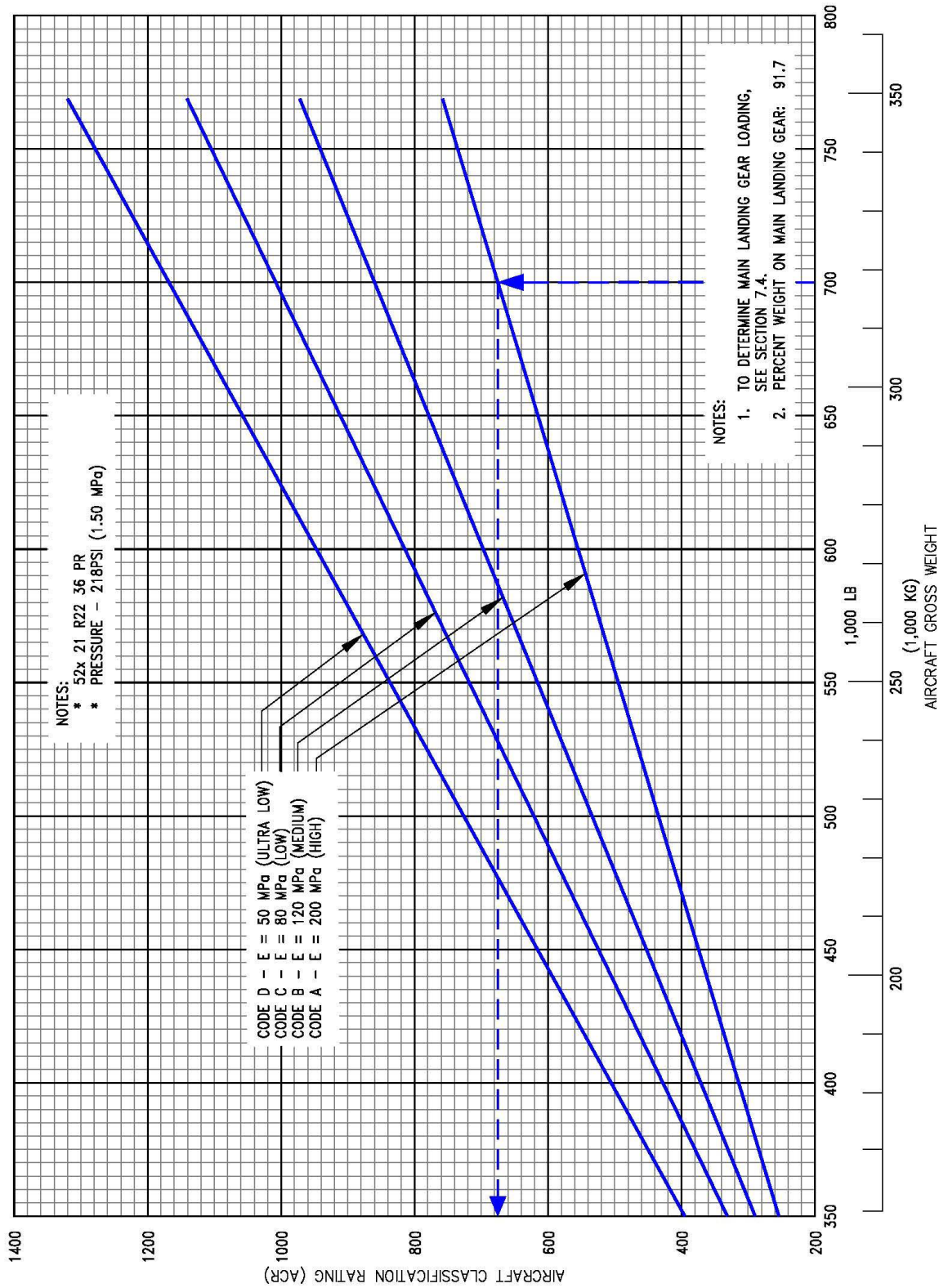

## 7.11.5 Aircraft Classification Rating - Rigid Pavement: Model 777-200LR

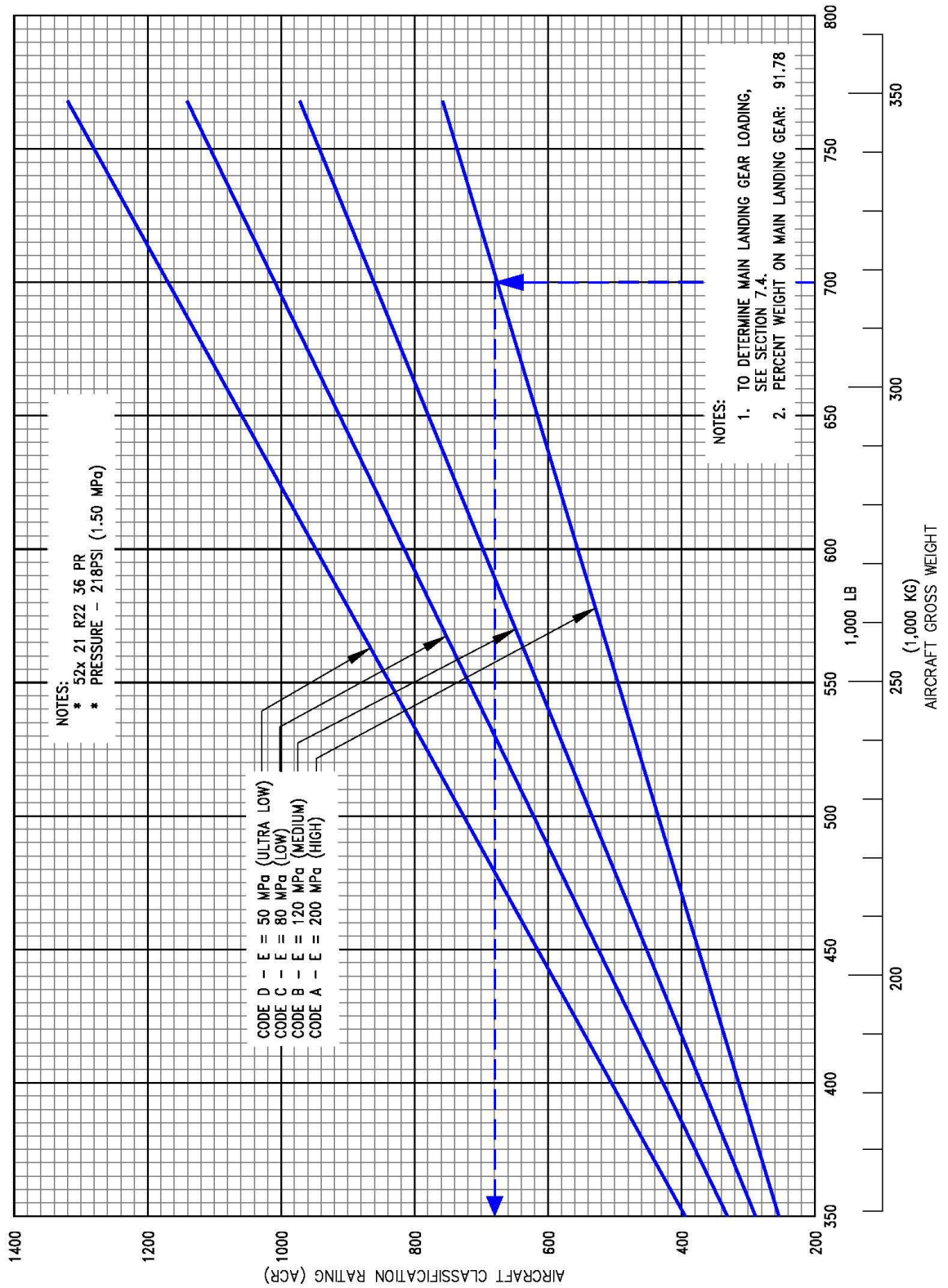

D6-58329-2

REV F

December 2022

7-37

## 7.11.6 Aircraft Classification Rating - Rigid Pavement: Model 777-300ER

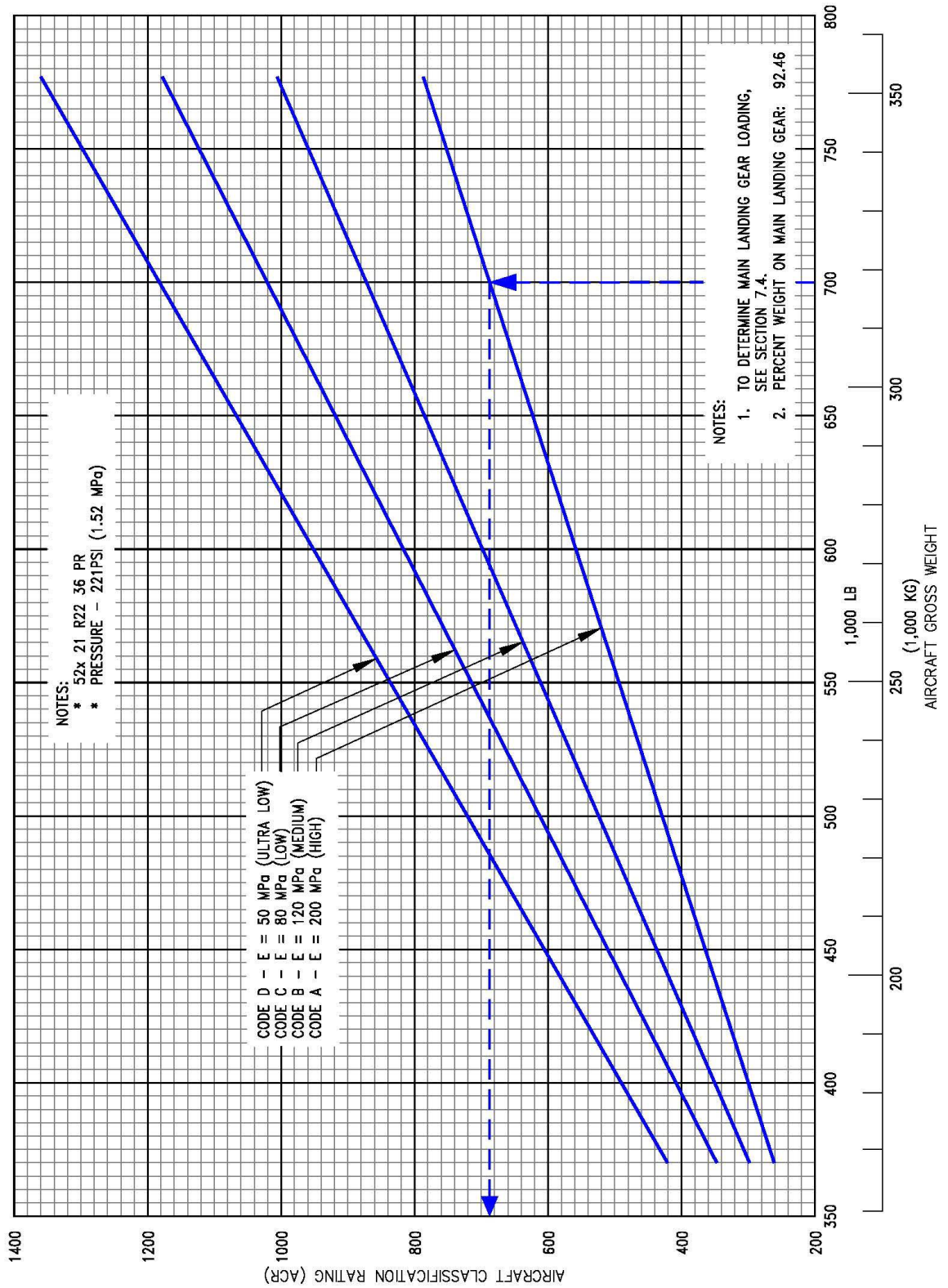

D6-58329-2

REV F

December 2022

7-38

---

## 8.0 FUTURE 777 DERIVATIVE AIRPLANES

Several derivatives are being studied to provide additional capabilities of the 777 family of airplanes. Future growth versions could require additional passenger capacity or increased range or both. Whether these growth versions could be built would depend entirely on airline requirements. In any event, impact on airport facilities will be a consideration in the configuration and design.

---

## 9.0 SCALED 777 DRAWINGS

The drawings in the following pages show airplane plan view drawings, drawn to approximate scale as noted. The drawings may not come out to exact scale when printed or copied from this document. Printing scale should be adjusted when attempting to reproduce these drawings. Three-view drawing files of the 777-200LR, 777-300ER and 777-Freighter, along with other Boeing airplane models, can be downloaded from the following website:

<http://www.boeing.com/airports>



## 9.1 MODEL 777-200LR

### 9.1.1 Scaled Drawings – 1:500: Model 777-200LR

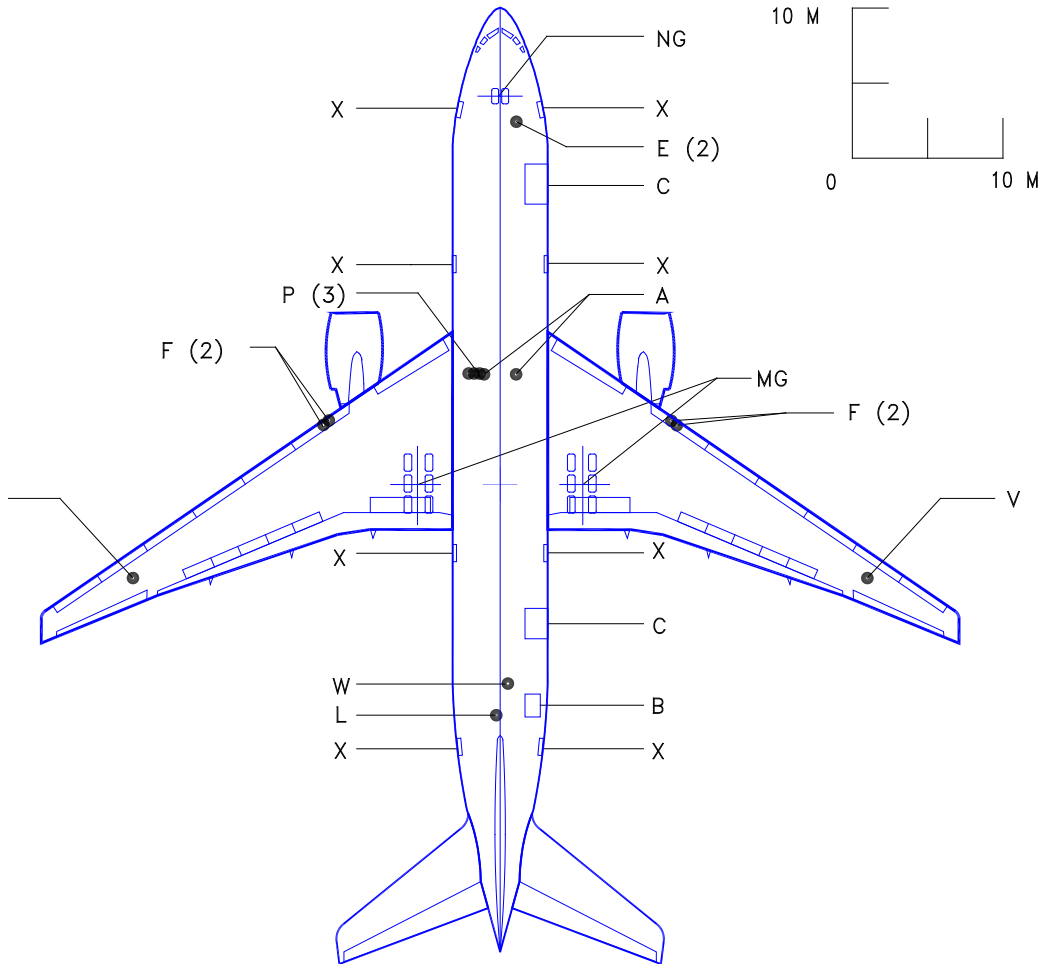

#### LEGEND

A	AIR CONDITIONING
B	BULK CARGO DOOR
C	CONTAINER CARGO DOOR
E	ELECTRICAL (2)
F	FUEL (2 CONNECTORS)
L	LAVATORY
MG	MAIN GEAR
NG	NOSE GEAR
P	PNEUMATIC PORT (3)
V	FUEL VENT
W	POTABLE WATER
X	PASSENGER DOOR

**NOTE: ADJUST SCALE WHEN PRINTING THIS PAGE**

D6-58329-2

REV F

December 2022

9-2

---

**9.1.2 Scaled Drawings – 1:500: Model 777-200LR**

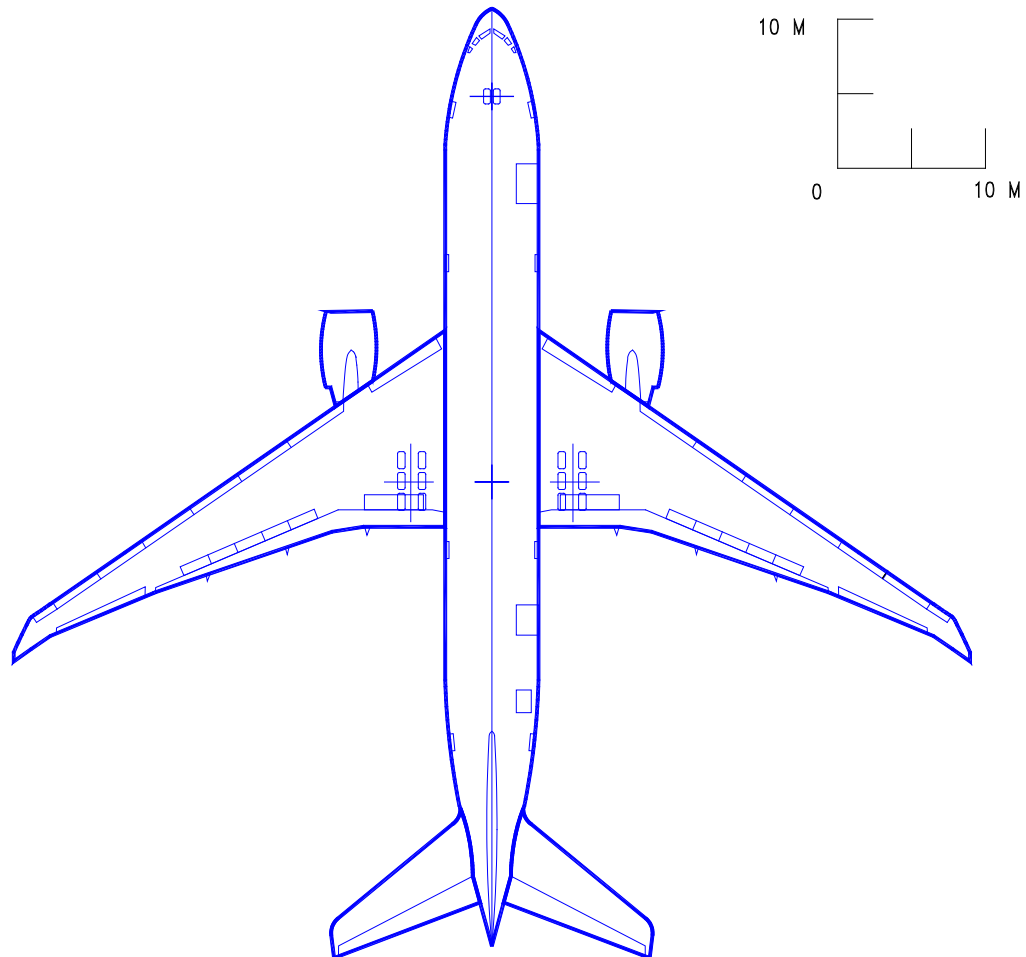

**NOTE: ADJUST SCALE WHEN PRINTING THIS PAGE**

## 9.2 MODEL 777-300ER

### 9.2.1 Scaled Drawings – 1:500: Model 777-300ER

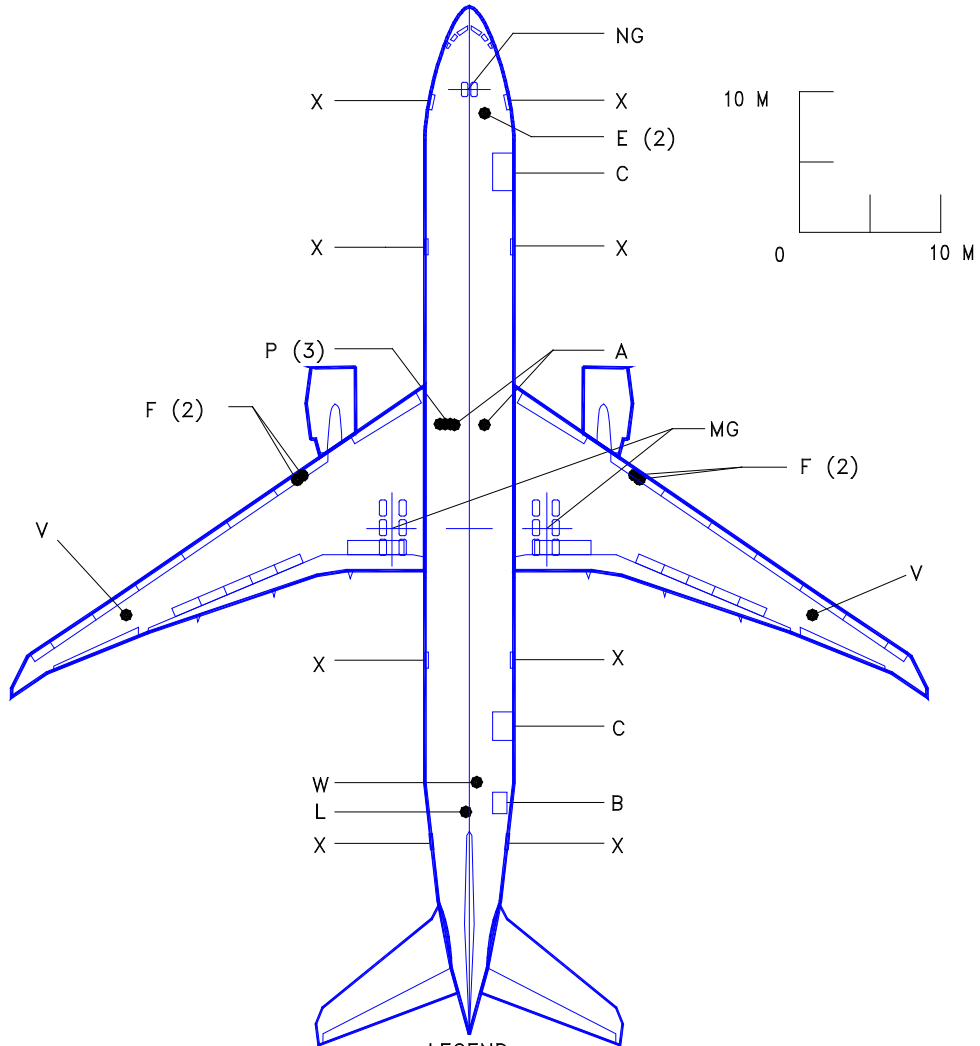

#### LEGEND

A	AIR CONDITIONING
B	BULK CARGO DOOR
C	CONTAINER CARGO DOOR
E	ELECTRICAL (2)
F	FUEL (2 CONNECTORS)
L	LAVATORY
MG	MAIN GEAR
NG	NOSE GEAR
P	PNEUMATIC PORT (3)
V	FUEL VENT
W	POTABLE WATER
X	PASSENGER DOOR

**NOTE: ADJUST SCALE WHEN PRINTING THIS PAGE**

D6-58329-2

REV F

December 2022

9-4

---

**9.2.2 Scaled Drawings – 1:500: Model 777-300ER**

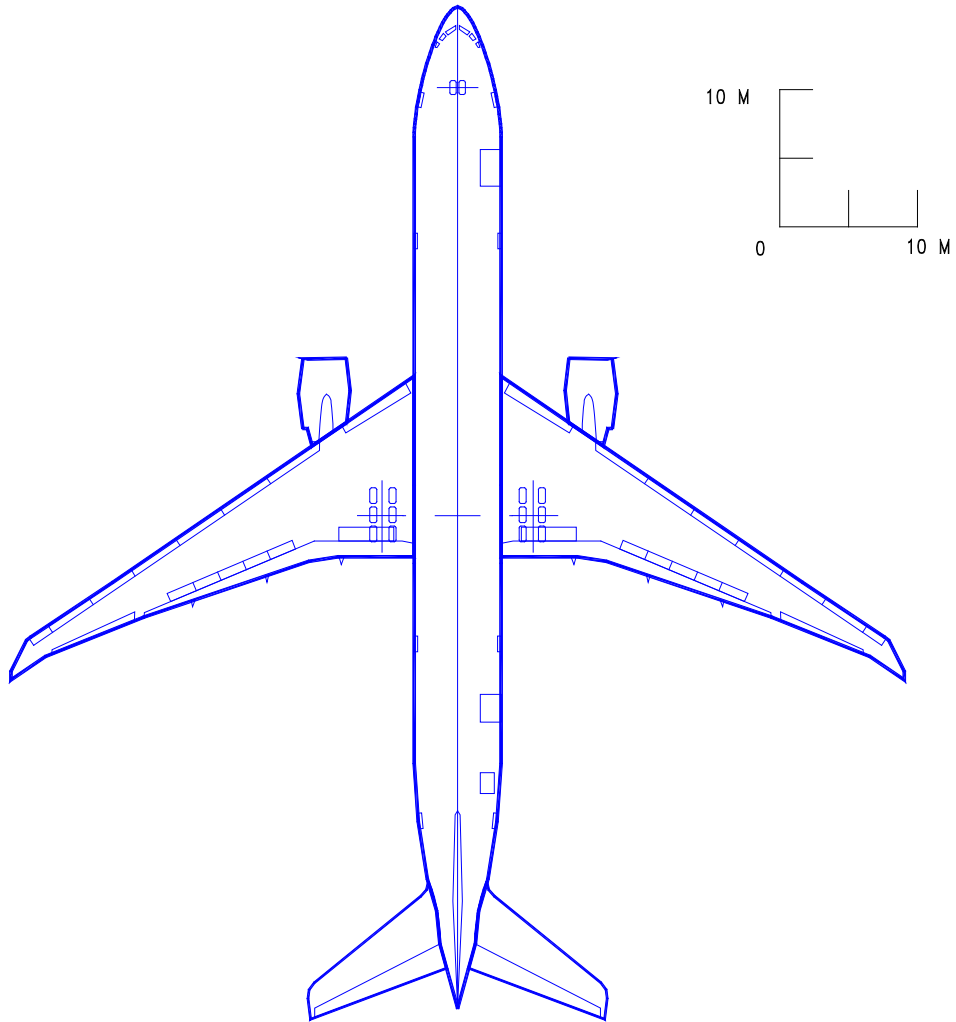

**NOTE: ADJUST SCALE WHEN PRINTING THIS PAGE**

---

## 9.3 MODEL 777 FREIGHTER

### 9.3.1 Scaled Drawings – 1:500: Model 777F

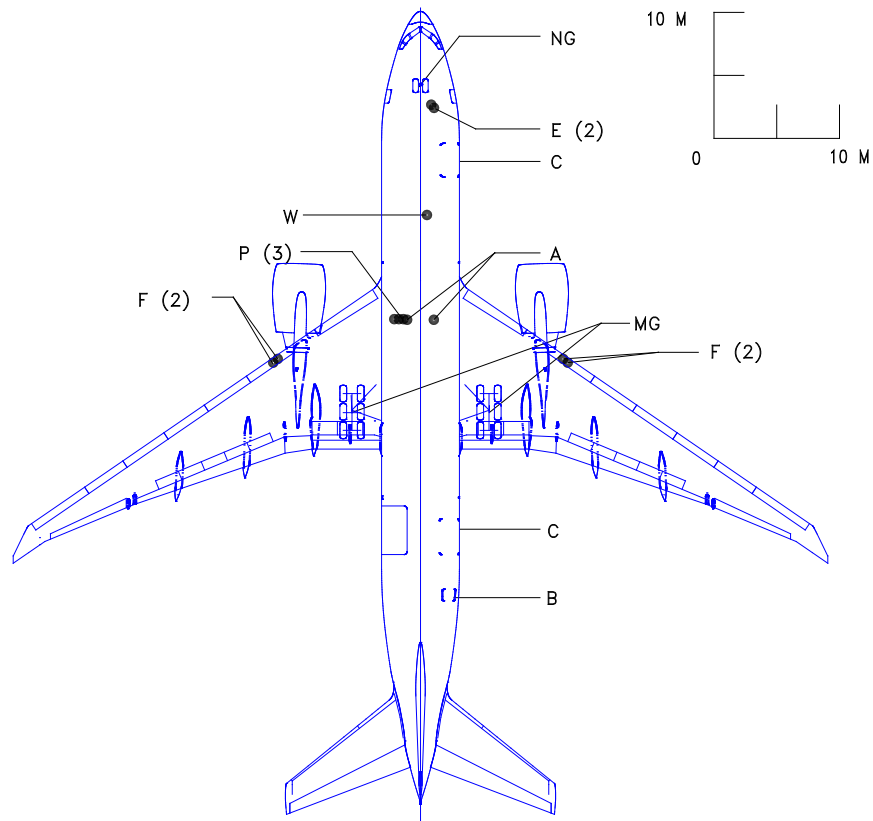

#### LEGEND

A	AIR CONDITIONING
B	BULK CARGO DOOR
C	CONTAINER CARGO DOOR
E	ELECTRICAL (2)
F	FUEL (2 CONNECTORS)
MG	MAIN GEAR
NG	NOSE GEAR
P	PNEUMATIC PORT (3)
W	POTABLE WATER

**NOTE: ADJUST SCALE WHEN PRINTING THIS PAGE**

---

### 9.3.2 Scaled Drawings – 1:500: Model 777F

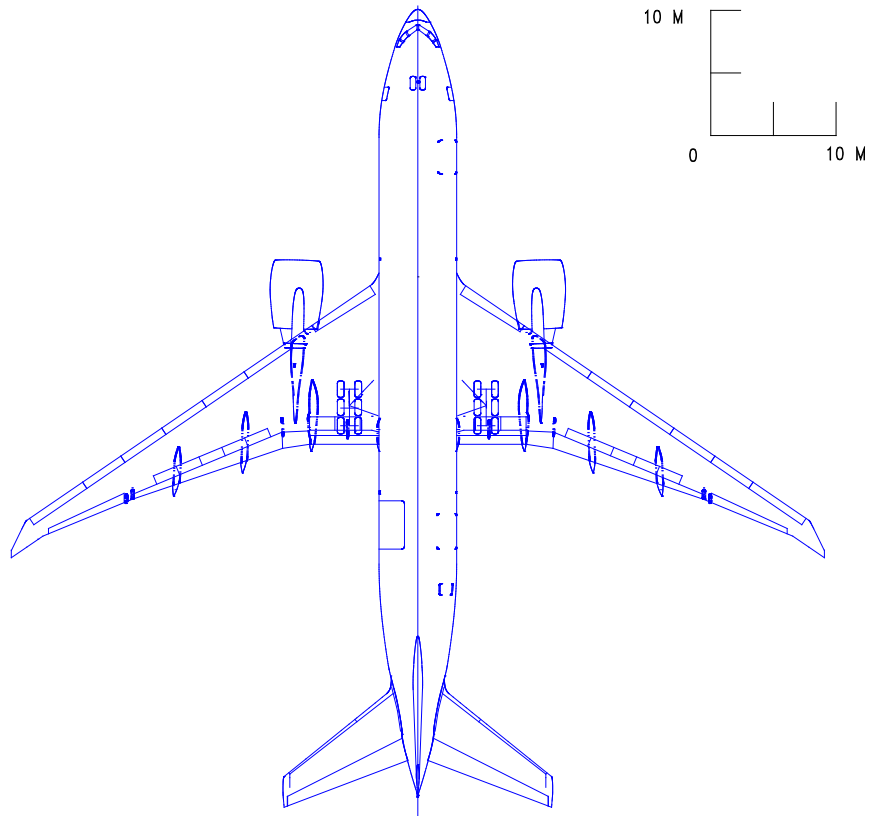

**NOTE: ADJUST SCALE WHEN PRINTING THIS PAGE**