

DC-8 SERIES
AIRPLANE
CHARACTERISTICS
FOR
AIRPORT PLANNING
1989

To Whom It May Concern:

This document is intended for airport planning purposes. Specific aircraft operational requirements are established by the airline which will use the airport under consideration.

Questions concerning the use of this document should be address to:

Boeing Commercial Airplanes
P.O. Box 3707
Seattle, Washington 98124-2207
U.S.A.

Attention: Manager, Airport Technology
Mail Code: 20-93
Email: AirportTechnology@boeing.com
Website: www.boeing.com/airports

Not Subject to US Export Administration Regulations (EAR), (15 C.F.R. Parts 730-774)
or US International Traffic in Arms Regulations (ITAR), (22 C.F.R. Parts 120-130).

CONTENTS

	Page
1.0 SCOPE	1
1.1 Purpose	1
1.2 Introduction	2
2.0 AIRPLANE DESCRIPTION	3
2.1 General Airplane Characteristics	3
2.2 General Airplane Dimensions	8
2.3 Ground Clearances	12
2.4 Interior Arrangements	21
2.4.1 Passengers	21
2.4.2 Cargo	25
2.5 Passenger Cabin Cross Section	28
2.5.1 First-Class Seating	28
2.5.2 Tourist Seating	29
2.6 Lower Compartments	30
2.7 Door Clearances	31
2.7.1 Forward Passenger Door	31
2.7.2 Aft Passenger Doors	32
2.7.3 Forward Buffet Doors	34
2.7.4 Aft Buffet Doors	36
2.7.5 Main Cargo Doors	38
2.7.6 Baggage Doors	39
2.7.7 Clearances Baggage Doors	42
3.0 AIRPLANE PERFORMANCE	45
3.1 General Information	45
3.2 Payload-Range	46
3.2.1 Payload-Range Capabilities for Step Altitude Cruise (U.S. Units)	46
3.2.2 Payload-Range Capabilities for Step Altitude Cruise (Metric)	58
3.3 FAR Takeoff Runway Length Requirements	70
3.3.1 Standard Day	70
3.3.2 Standard Day + 15°C	76
3.4 FAR Landing Runway Length Requirements	82
3.5 Approach Speed	87

CONTENTS
(Continued)

	Page
4.0 GROUND MANEUVERING	89
4.1 General Information	89
4.2 Turning Radii, No Slip Angle	90
4.3 Minimum Turning Radii	94
4.4 Visibility from Cockpit	98
4.5 Runway and Taxiway Turn Paths	99
4.5.1 More Than 90° Turn — Runway to Taxiway	99
4.5.2 90° Turn — Runway to Taxiway	103
4.5.3 90° Turn — Taxiway to Taxiway	107
4.6 Runway Holding Apron	114
5.0 TERMINAL SERVICING	119
5.1 Airplane Servicing Arrangement (Typical)	119
5.2 Terminal Operation, Turnaround Station	122
5.3 Terminal Operation, En Route Station	128
5.4 Ground Service Connections	130
5.5 Engine Starting Pneumatic Requirements	154
5.6 Ground Pneumatic Power Requirements	155
5.7 Preconditioned Airflow Requirements	156
5.8 Ground Towing Requirements	158
6.0 OPERATING CONDITIONS	159
6.1 Jet Engine Exhaust Velocities and Temperatures	159
6.1.1 Jet Engine Exhaust Velocity Contours, Breakaway Power	159
6.1.2 Jet Engine Exhaust Temperature Contours, Breakaway Power	163
6.1.3 Jet Engine Exhaust Velocity Contours, Takeoff Power	165
6.1.4 Jet Engine Exhaust Temperature Contours, Takeoff Power	167
6.1.5 Jet Engine Exhaust Velocity Contours, Idle Power	169
6.1.6 Jet Engine Exhaust Temperature Contours, Idle Power	171
6.2 Airport and Community Noise	173

**CONTENTS
(Continued)**

	Page
7.0 PAVEMENT DATA	177
7.1 General Information	177
7.2 Footprint	180
7.3 Maximum Pavement Loads	182
7.4 Landing Gear Loading on Pavement	183
7.5 Flexible Pavement Requirements, U.S. Corps of Engineers Design Method	192
7.6 Flexible Pavement Requirements, LCN Conversion	193
7.7 Rigid Pavement Requirements, Portland Cement Association Design Method	203
7.8 Rigid Pavement Requirements, LCN Conversion	212
7.8.1 Radius of Relative Stiffness	213
7.8.2 Rigid Pavement Requirements, LCN Conversion	214
7.8.3 Radius of Relative Stiffness	223
7.8.4 Effect on Radius of Relative Stiffness	224
7.9 ACN-PCN Reporting System	225
7.9.1 Aircraft Classification Number — Flexible Pavement	226
7.9.2 Aircraft Classification Number — Rigid Pavement	227
7.9.3 Development of ACN Charts	228
7.9.4 Development of Aircraft Classification Number (ACN) — Flexible Pavement .	229
7.9.5 Development of Aircraft Classification Number (ACN) — Rigid Pavement . . .	231
8.0 POSSIBLE DC-8 DERIVATIVE AIRPLANES	233
9.0 SCALE DRAWINGS	235

1.0 SCOPE

1.1 Purpose

This document provides, in a standardized format, minimum airplane characteristics data for general airport planning. There are numerous versions of the model DC-8.* The DC-8 data in this document are for the most critical model in each series considering airport operations. Since operational practices vary among airlines, specific data should be coordinated with the using airlines prior to facility design. McDonnell Douglas should be contacted for any additional information required.

Content of the document reflects the results of a coordinated effort by representatives from the following organizations:

Aerospace Industries Association
Airport Operators Council International
Air Transport Association of America
International Air Transport Association

*The following DC-8 models have been certificated by the FAA to date: DC-8-11, DC-8-12, DC-8-21, DC-8-31, DC-8-32, DC-8-33, DC-8-41, DC-8-42, DC-8-43, DC-8-51, DC-8-52, DC-8-53, DC-8-54F, DC-8-55, DC-8-55F, DC-8-61, DC-8-61CF, DC-8-62, DC-8-62AF, DC-8-62CF, DC-8-63, DC-8-63AF, DC-8-63CF, DC-8-71, DC-8-71F, DC-8-72, DC-8-72F, DC-8-73, DC-8-73F.

1.2 Introduction

This document conforms to NAS 3601. It provides McDonnell Douglas DC-8 characteristics for airport operators, airlines, and engineering consultant organizations. Since airplane changes and available options may alter the information, the data presented herein must be regarded as subject to change.

For further information contact:

Boeing Commercial Airplanes
P.O. Box 3707
Seattle, Washington 98124-2207
U.S.A.

Attention: Manager, Airport Technology
Mail Code: 20-93
Email: AirportTechnology@boeing.com
Website: www.boeing.com/airports

2.0 AIRPLANE DESCRIPTION

2.1 General Airplane Characteristics — McDonnell Douglas DC-8 (Definitions Refer to Items in Figure 2.1)

Maximum Design Taxi Weight (MTW). Maximum weight for ground maneuver as limited by aircraft strength and airworthiness requirements. (It includes weight of taxi and runup fuel.)

Maximum Design Landing Weight (MLW). Maximum weight for landing as limited by aircraft strength and airworthiness requirements.

Maximum Design Takeoff Weight (MTOW). Maximum weight for takeoff as limited by aircraft strength and airworthiness requirements. (This is the maximum weight at start of the takeoff run.)

Operating Empty Weight (OEW). Weight of structure, power plant, furnishings, systems, unusable fuel and other unusable propulsion agents, and other items of equipment that are considered an integral part of a particular airplane configuration. Also included are certain standard items, personnel, equipment, and supplies necessary for full operation, excluding usable fuel and payload.

Maximum Design Zero Fuel Weight (MZFW). Maximum weight allowed before usable fuel and other specified usable agents must be loaded in defined sections of the aircraft as limited by strength and airworthiness requirements.

Maximum Payload. Maximum design zero fuel weight minus operational empty weight.

Maximum Seating Capacity. The maximum number of passengers specifically certified or anticipated for certification.

Maximum Cargo Volume. The maximum space available for cargo.

Usable Fuel. Fuel available for aircraft propulsion.

		MODEL DC-8-43	MODEL DC-8-55	MODEL DC-8-55F*
MAXIMUM DESIGN TAXI WEIGHT	POUNDS	318,000	328,000	328,000
	KILOGRAMS	144,245	148,781	148,781
MAXIMUM DESIGN LANDING WEIGHT	POUNDS	207,000	217,000	240,000
	KILOGRAMS	93,895	98,431	108,864
MAXIMUM DESIGN TAKEOFF WEIGHT	POUNDS	315,000	325,000	325,000
	KILOGRAMS	142,884	147,420	147,420
OPERATING EMPTY WEIGHT	POUNDS	136,509	138,266	131,230
	KILOGRAMS	61,920	62,717	59,526
MAXIMUM DESIGN ZERO FUEL WEIGHT	POUNDS	178,200	190,000	224,000
	KILOGRAMS	80,832	86,184	101,606
MAXIMUM PAYLOAD	POUNDS	41,691	51,734	92,770
	KILOGRAMS	18,911	23,467	42,080
MAXIMUM SEATING CAPACITY SEE PAGES 21 AND 22	PASSENGERS	177	189	0
MAXIMUM CARGO VOLUME	CUBIC FEET	1390	1390	9020
	CUBIC METERS	39.4	39.4	255.4
USABLE FUEL	U.S. GALLONS	23,393	23,393	23,393
	LITERS	88,552	88,552	88,552

*DC-8-55F – ALL FREIGHTER

2.1 GENERAL AIRPLANE CHARACTERISTICS

MODEL DC-8-43, -55, -55F

		MODEL DC-8-61	MODEL DC-8-61F*	MODEL DC-8-62	MODEL DC-8-62F*
MAXIMUM DESIGN TAXI WEIGHT	POUNDS	328,000	331,000	353,000	353,000
	KILOGRAMS	148,781	150,142	160,121	160,121
MAXIMUM DESIGN LANDING WEIGHT	POUNDS	240,000	258,000	240,000	250,000
	KILOGRAMS	108,864	117,029	108,864	113,400
MAXIMUM DESIGN TAKEOFF WEIGHT	POUNDS	325,000	328,000	350,000	350,000
	KILOGRAMS	147,420	148,781	158,760	158,760
OPERATING EMPTY WEIGHT	POUNDS	152,101	145,506	143,255	138,560
	KILOGRAMS	68,993	66,002	64,980	62,851
MAXIMUM DESIGN ZERO FUEL WEIGHT	POUNDS	224,000	234,000	195,000	230,000
	KILOGRAMS	101,606	106,142	88,452	104,328
MAXIMUM PAYLOAD	POUNDS	71,877	88,494	51,745	91,440
	KILOGRAMS	32,603	40,141	23,472	41,477
MAXIMUM SEATING CAPACITY SEE PAGES 23 AND 24	PASSENGERS	259	0	189	0
MAXIMUM CARGO VOLUME	CUBIC FEET	2500	12,171	1,615	9737
	CUBIC METERS	70.8	344.6	45.7	275.7
USABLE FUEL	U.S. GALLONS	23,393	23,393	24,275	24,275
	LITERS	88,552	88,552	91,891	91,891

*DC-8-61F, -62F — CONVERTIBLES CARGO MODE

2.1 GENERAL AIRPLANE CHARACTERISTICS MODEL DC-8-61, -61F, -62, -62F

		MODEL DC-8-63	MODEL DC-8-63F*
MAXIMUM DESIGN TAXI WEIGHT	POUNDS	358,000	358,000
	KILOGRAMS	162,389	162,389
MAXIMUM DESIGN LANDING WEIGHT	POUNDS	258,000	275,000
	KILOGRAMS	117,029	124,740
MAXIMUM DESIGN TAKEOFF WEIGHT	POUNDS	355,000	355,000
	KILOGRAMS	161,028	161,028
OPERATING EMPTY WEIGHT	POUNDS	158,738	141,330
	KILOGRAMS	72,004	64,107
MAXIMUM DESIGN ZERO FUEL WEIGHT	POUNDS	230,000	261,000
	KILOGRAMS	104,328	118,390
MAXIMUM PAYLOAD	POUNDS	71,262	119,670
	KILOGRAMS	32,324	54,282
MAXIMUM SEATING CAPACITY SEE PAGE 24	PASSENGERS	259	0
MAXIMUM CARGO VOLUME	CUBIC FEET	2500	12,830
	CUBIC METERS	70.8	363.3
USABLE FUEL	U.S. GALLONS	24,275	24,275
	LITERS	91,891	91,891

*DC-8-63F — ALL FREIGHTER

2.1 GENERAL AIRPLANE CHARACTERISTICS MODEL DC-8-63, and -63F

		MODEL					
		71	71F	72*	72F	73*	73F*
MAXIMUM DESIGN TAXI WEIGHT	POUNDS	328,000	331,000	338,000	338,000	358,000	358,000
	KILOGRAMS	148,781	150,142	153,317	153,317	162,389	162,389
MAXIMUM DESIGN LANDING WEIGHT	POUNDS	240,000	258,000	240,000	250,000	275,000	275,000
	KILOGRAMS	108,864	117,029	108,864	113,400	117,029	124,740
MAXIMUM DESIGN TAKEOFF WEIGHT	POUNDS	325,000	328,000	335,000	335,000	355,000	355,000
	KILOGRAMS	147,420	148,781	151,956	151,956	161,028	161,028
OPERATING EMPTY WEIGHT	POUNDS	163,700	152,700	153,200	140,200	166,200	149,200
	KILOGRAMS	74,254	69,265	69,492	63,595	75,388	67,677
MAXIMUM DESIGN ZERO FUEL WEIGHT	POUNDS	224,000	234,000	195,000	231,000	231,000	261,000
	KILOGRAMS	101,606	106,142	88,452	104,328	104,328	118,390
MAXIMUM PAYLOAD	POUNDS	60,200	81,300	41,800	90,800	64,800	111,800
	KILOGRAMS	27,307	36,878	18,960	40,733	28,940	50,712
MAXIMUM SEATING CAPACITY SEE PAGES 23 AND 24	PASSENGERS	259	0	189	0	259	0
MAXIMUM CARGO VOLUME	CUBIC FEET	2,500	12,171	1,615	9,737	2,500	12,830
	CUBIC METERS	70.8	344.6	45.7	275.7	70.8	363.3
USABLE FUEL	GALLONS	23,393	23,393	24,275	24,275	24,275	24,275
	LITERS	88,552	88,552	91,891	91,891	91,891	91,891

*SOME AIRCRAFT ARE CERTIFICATED TO MAXIMUM DESIGN TAXI WEIGHTS OF FROM 353,000 POUNDS TO 362,500 POUNDS.

2.1 GENERAL AIRPLANE CHARACTERISTICS MODEL DC-8-71, -71F, -72, -72F, -73, AND -73F

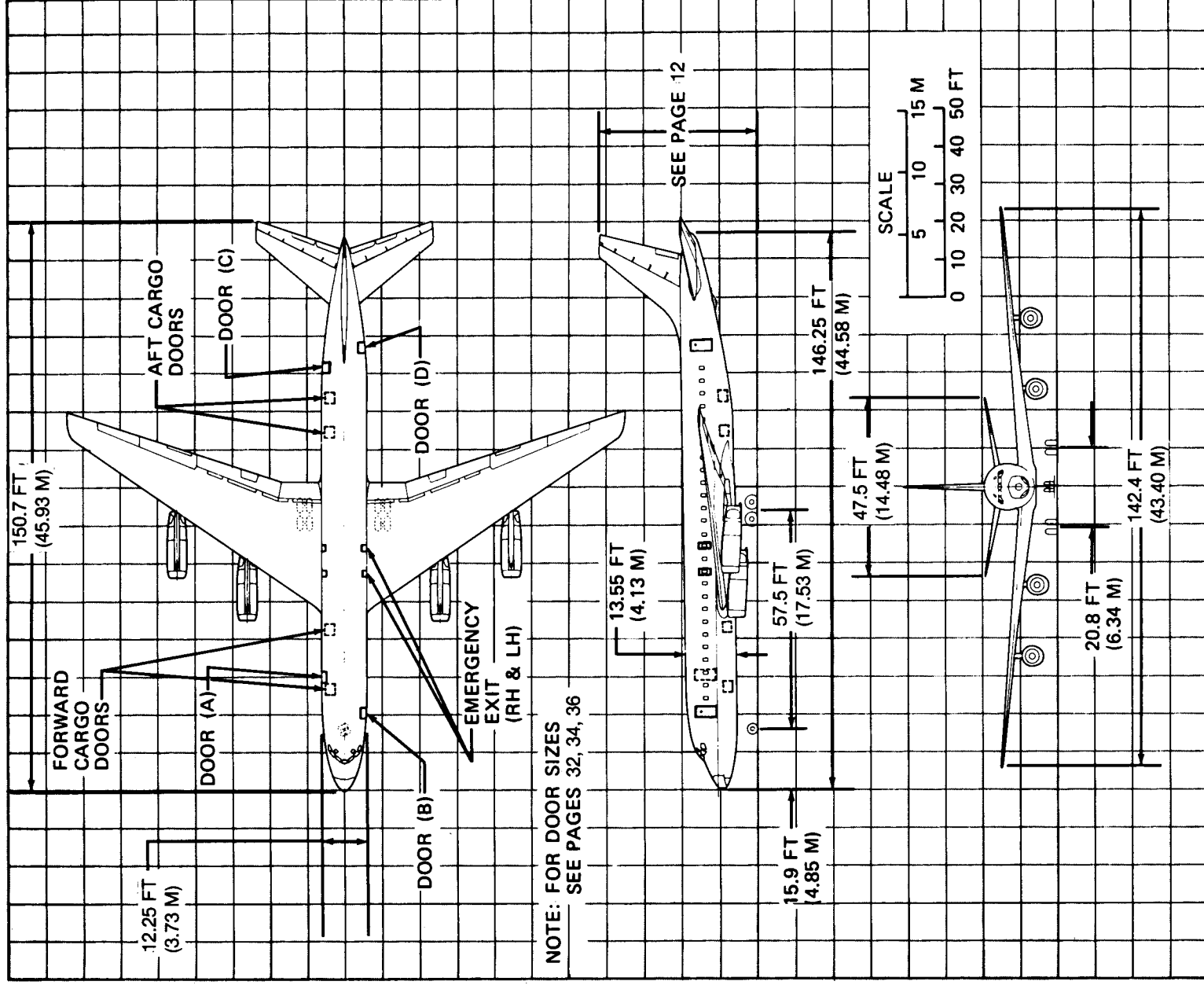

2.2 GENERAL AIRPLANE DIMENSIONS MODEL DC-8-43

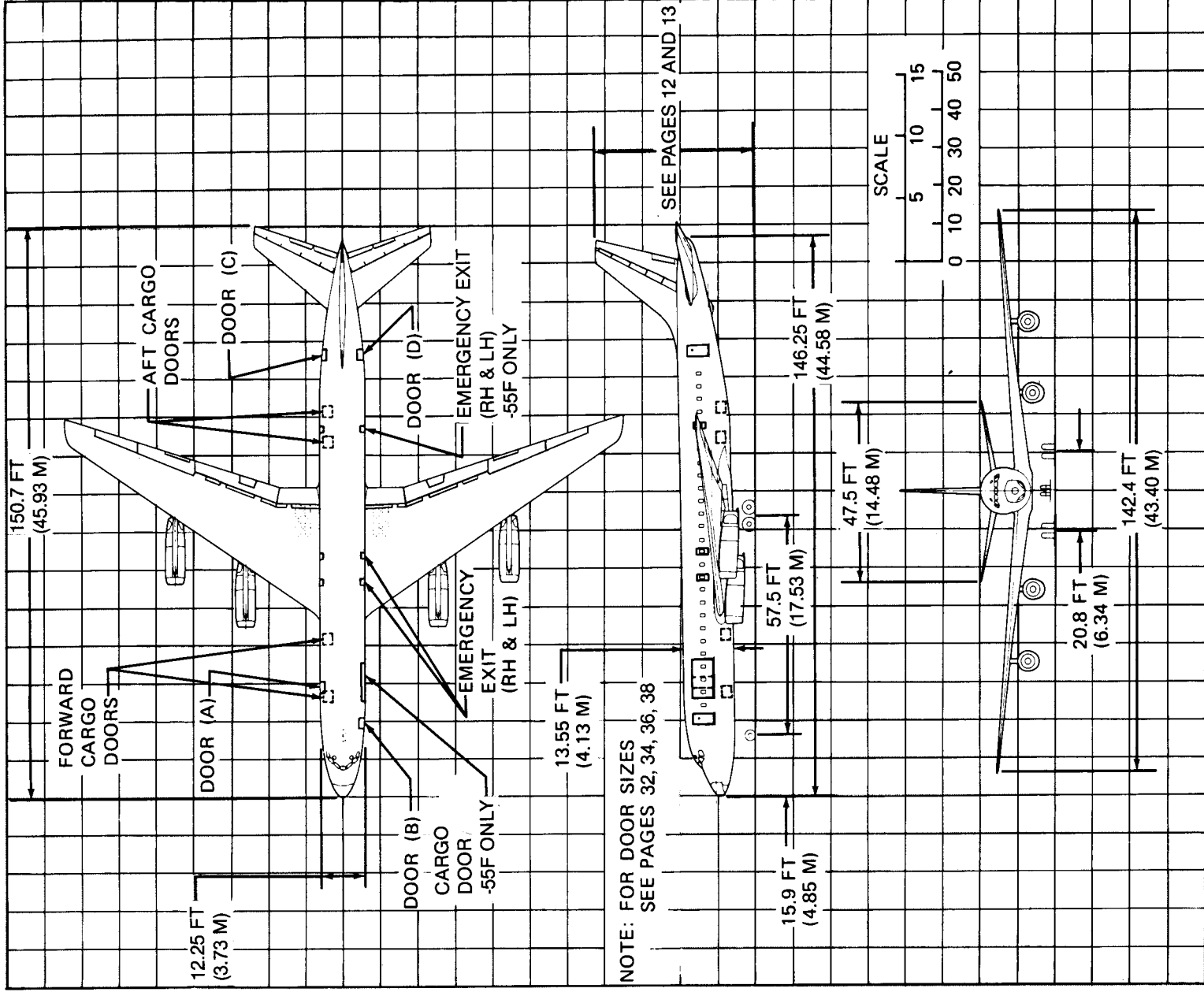

2.2 GENERAL AIRPLANE DIMENSIONS MODEL DC-8-55, -55F

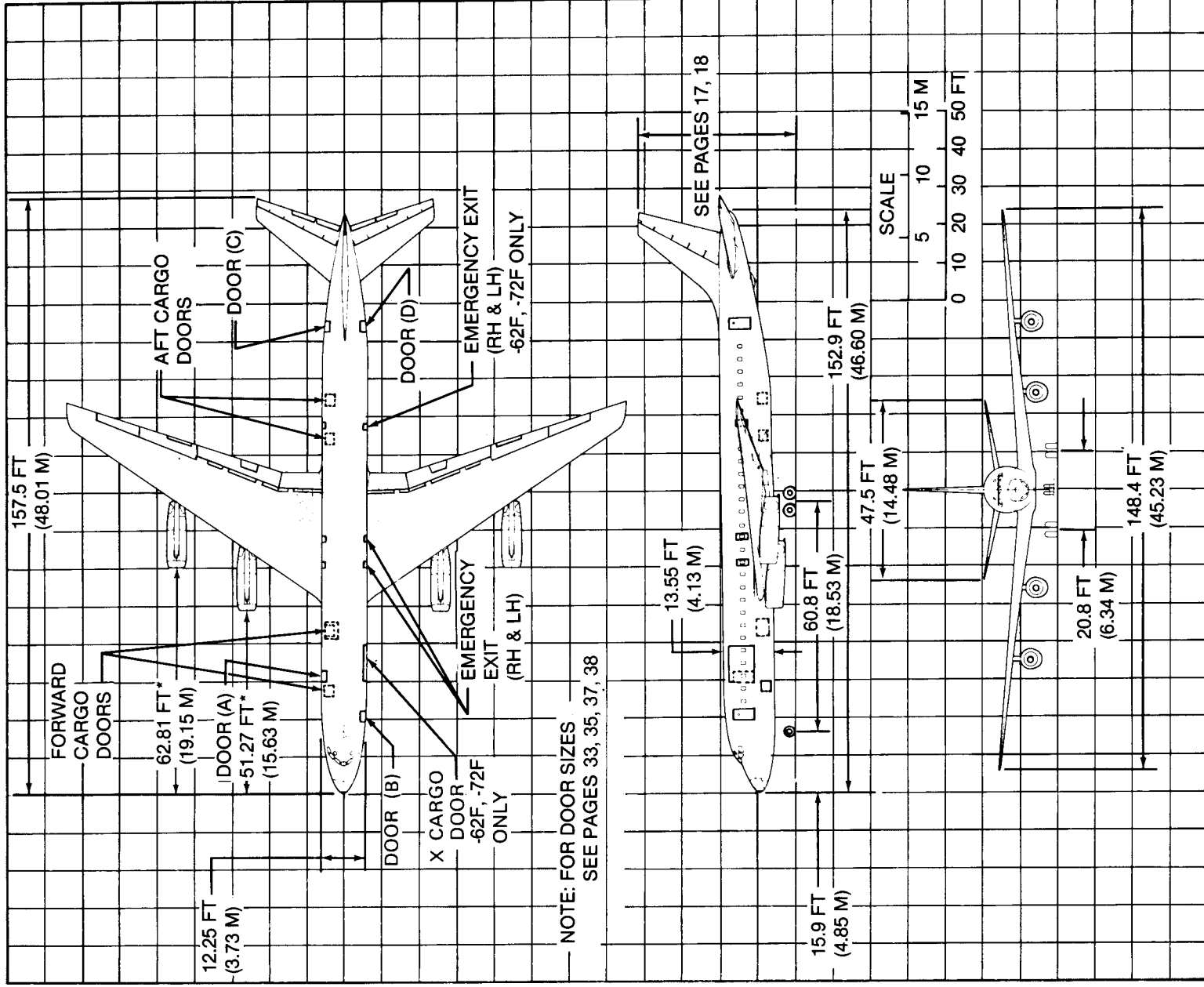

*SERIES 72 & 72F ONLY

2.2 GENERAL AIRPLANE DIMENSIONS MODEL DC-8-62, -62F, 72, 72F

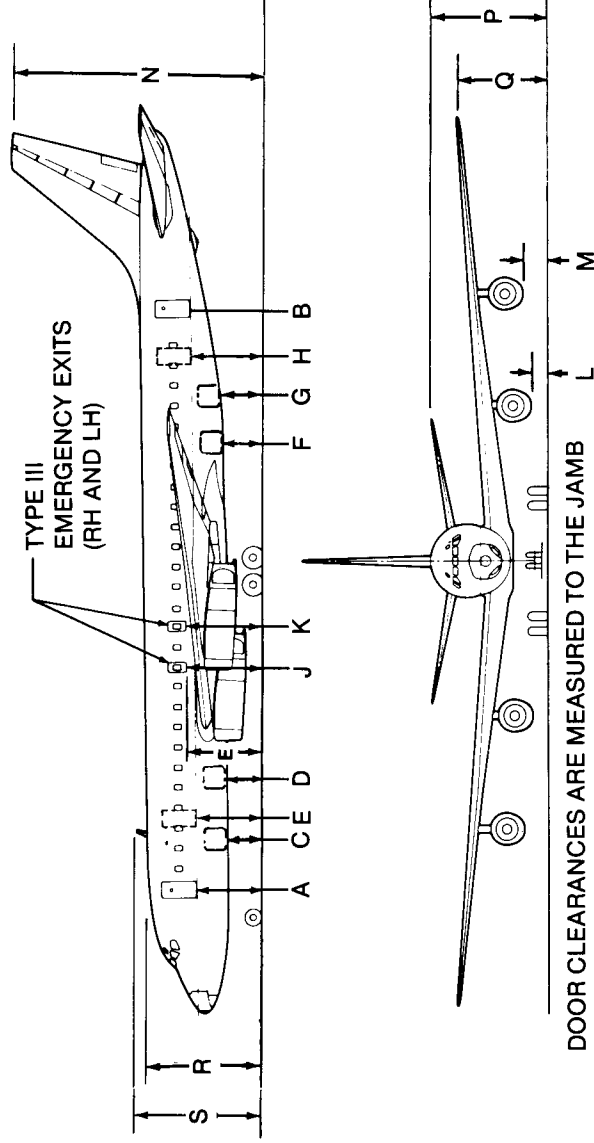

DC-8-43

VERTICAL CLEARANCES				
	MAXIMUM		MINIMUM	
	FT - IN.	METERS	FT - IN.	METERS
A	11 - 2.0	3.40	10 - 6.2	3.21
B	13 - 1.1	3.99	12 - 0.9	3.68
C	6 - 7.1	2.01	5 - 11.5	1.82
D	6 - 9.8	2.08	6 - 2.5	1.89
E	11 - 4.1	3.46	10 - 8.5	3.26
F	7 - 9.0	2.36	6 - 11.8	2.13
G	8 - 0.1	2.44	7 - 1.9	2.18
H	12 - 11.5	3.95	12 - 0	3.66
J	13 - 1.5	4.00	12 - 6.5	3.82
K	13 - 2.8	4.03	12 - 7.9	3.86
L	3 - 9.6	1.16	3 - 2.7	0.98
M	5 - 3.4	1.61	4 - 7.7	1.41
N	43 - 5.2	13.24	42 - 1.7	12.84
P	21 - 6.5	6.57	20 - 2.5	6.16
Q	15 - 9.6	4.82	14 - 11.6	4.56
R	19 - 6.0	5.94	18 - 10.4	5.75
S	20 - 5.0	6.22	19 - 9.4	6.03

IT IS RECOMMENDED THAT ± 3 INCHES BE ALLOWED FOR VERTICAL EXCURSIONS DUE TO LOADING, VARYING STRUT AND TIRE INFLATIONS, PAVEMENT UNEVENNESS, ETC.

- VALUES SHOWN ARE FOR CERTIFIED WEIGHT AND CG LIMITS SPECIFIED FOR GROUND OPERATIONS.
- VALUES APPLY TO STATIC AIRCRAFT ON A FLAT, LEVEL SURFACE.

2.3 GROUND CLEARANCE MODEL DC-8-43

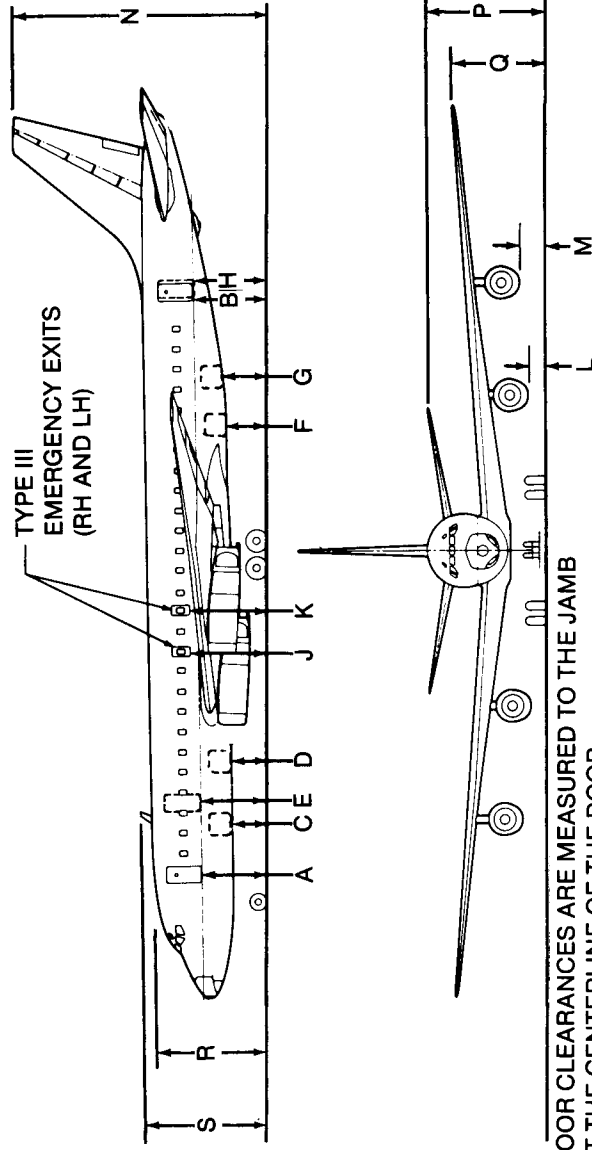

DC-8-55

VERTICAL CLEARANCES				
	MAXIMUM		MINIMUM	
	FT - IN.	METERS	FT - IN.	METERS
A	11 - 1.9	3.40	10 - 6.2	3.21
B	13 - 2.3	4.02	12 - 0.9	3.68
C	6 - 7.1	2.00	5 - 11.5	1.82
D	6 - 10.0	2.08	6 - 2.5	1.89
E	11 - 4.1	3.46	10 - 8.5	3.26
F	7 - 9.9	2.39	6 - 11.9	2.13
G	8 - 1.1	2.47	7 - 1.9	2.18
H	13 - 2.3	4.02	12 - 0.9	3.68
J	13 - 1.9	4.01	12 - 6.6	3.83
K	13 - 3.3	4.05	12 - 8.1	3.86
L	3 - 8.6	1.13	3 - 1.3	0.95
M	5 - 1.7	1.57	4 - 6.5	1.38
N	43 - 6.7	13.28	42 - 1.7	12.85
P	21 - 8.1	6.61	20 - 2.6	6.16
Q	15 - 10.5	4.84	14 - 11.6	4.56
R	19 - 6.0	5.94	18 - 10.3	5.75
S	20 - 5.0	6.22	19 - 9.3	6.03

IT IS RECOMMENDED THAT ± 3 INCHES BE ALLOWED FOR VERTICAL EXCURSIONS DUE TO LOADING, VARYING STRUT AND TIRE INFLATIONS, PAVEMENT UNEVENNESS, ETC.

- VALUES SHOWN ARE FOR CERTIFIED WEIGHT AND CG LIMITS SPECIFIED FOR GROUND OPERATIONS.
- VALUES APPLY TO STATIC AIRCRAFT ON A FLAT, LEVEL SURFACE.

2.3 GROUND CLEARANCE MODEL DC-8-55

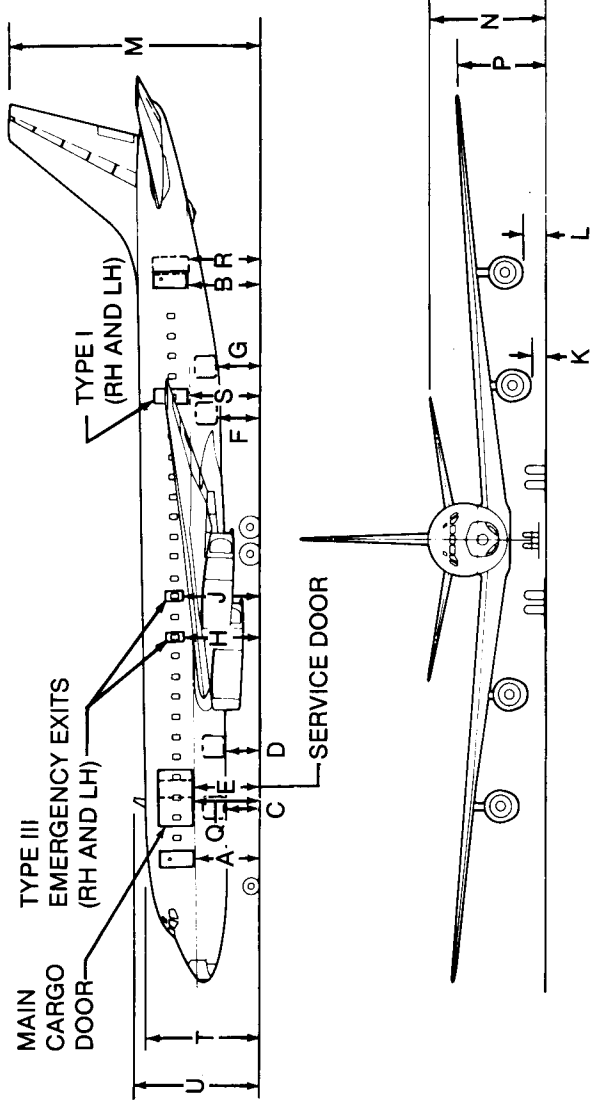

DOOR CLEARANCES ARE MEASURED TO THE JAMB AT THE CENTERLINE OF THE DOOR

DC-8-55F

VERTICAL CLEARANCES			
	MAXIMUM		MINIMUM
	FT - IN.	METERS	FT - IN. METERS
A	11 - 2.4	3.41	10 - 6.0 3.20
B	13 - 4.0	4.06	12 - 0.6 3.67
C	6 - 6.0	2.02	5 - 11.3 1.81
D	6 - 10.5	2.10	6 - 2.4 1.89
E	11 - 4.6	3.47	10 - 8.4 3.26
F	7 - 11.0	2.41	6 - 11.7 2.13
G	8 - 2.5	2.50	7 - 1.6 2.17
H	13 - 2.5	4.03	12 - 6.6 3.83
J	13 - 3.9	4.06	12 - 8.1 3.86
K	3 - 9.2	1.15	3 - 1.2 0.94
L	5 - 2.3	1.58	4 - 6.5 1.38
M	43 - 8.9	13.33	42 - 1.3 12.84
N	21 - 10.4	6.66	20 - 2.3 6.15
P	15 - 11.8	4.87	14 - 11.4 4.56
Q	11 - 4.5	3.47	10 - 8.3 3.26
R	13 - 4.5	4.08	12 - 0.9 3.68
S	12 - 9.1	3.89	11 - 9.0 3.58
T	19 - 6.5	5.96	18 - 10.1 5.74
U	20 - 5.5	6.24	19 - 9.1 6.02

IT IS RECOMMENDED THAT ± 3 INCHES BE ALLOWED FOR VERTICAL EXCURSIONS DUE TO LOADING, VARYING STRUT AND TIRE INFLATIONS, PAVEMENT UNEVENNESS, ETC.

- VALUES SHOWN ARE FOR CERTIFIED WEIGHT AND CG LIMITS SPECIFIED FOR GROUND OPERATIONS.
- VALUES APPLY TO STATIC AIRCRAFT ON A FLAT, LEVEL SURFACE.

2.3 GROUND CLEARANCE MODEL DC-8-55F

EMERGENCY EXITS (RH AND LH)

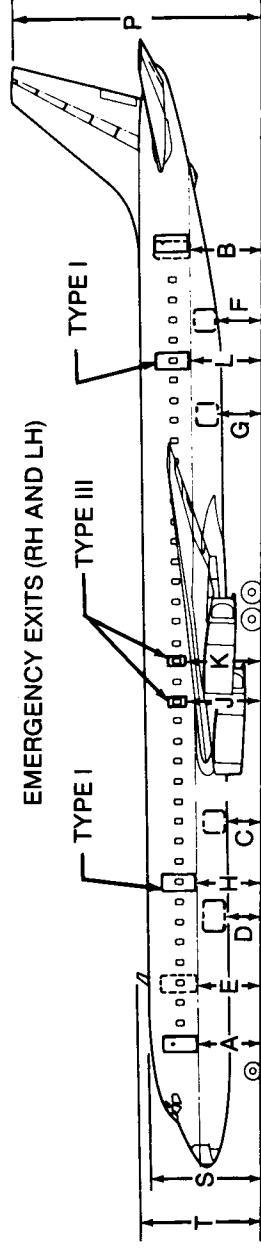

DOOR CLEARANCES ARE MEASURED TO THE JAMB AT THE CENTERLINE OF THE DOOR

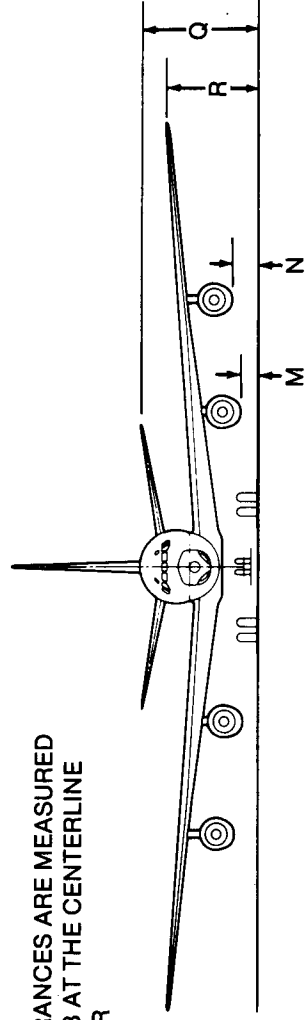

DC-8-61, -71

VERTICAL CLEARANCES				
	MAXIMUM		MINIMUM	
	FT - IN.	METERS	FT - IN.	METERS
A	11 - 3.6	3.44	10 - 6.1	3.20
B	13 - 1.2	3.99	12 - 0.6	3.67
C	7 - 0	2.13	6 - 4.6	1.96
D	6 - 11.0	2.11	6 - 2.6	1.89
E	11 - 4.8	3.47	10 - 7.8	3.25
F	8 - 1.2	2.47	7 - 2.4	2.21
G	7 - 10.9	2.41	7 - 1.6	2.17
H	11 - 7.1	3.53	10 - 11.1	3.33
J	13 - 2.4	4.04	12 - 7.8	3.86
K	13 - 3.2	4.04	12 - 8.9	3.88
L	12 - 7.7	3.85	11 - 9.6	3.60
M*	3 - 9.6	1.16	3 - 2.7	0.98
N*	5 - 1.6	1.56	4 - 7.3	2.79
P	43 - 2.7	13.17	41 - 11.7	12.79
Q	21 - 3.7	6.49	20 - 0.2	6.10
R	15 - 7.4	4.76	14 - 10.4	14.87
S	19 - 7.0	5.97	18 - 9.9	6.22
T	20 - 6.0	6.25	19 - 8.9	6.50

*SERIES-71 IS 10 INCHES LESS (0.25M)

IT IS RECOMMENDED THAT ± 3 INCHES BE ALLOWED FOR VERTICAL EXCURSIONS DUE TO LOADING, VARYING STRUT AND TIRE INFLATIONS, PAVEMENT UNEVENNESS, ETC.

- VALUES SHOWN ARE FOR CERTIFIED WEIGHT AND CG LIMITS SPECIFIED FOR GROUND OPERATIONS.
- VALUES APPLY TO STATIC AIRCRAFT ON A FLAT, LEVEL SURFACE.

2.3 GROUND CLEARANCE MODEL DC-8-61, -71

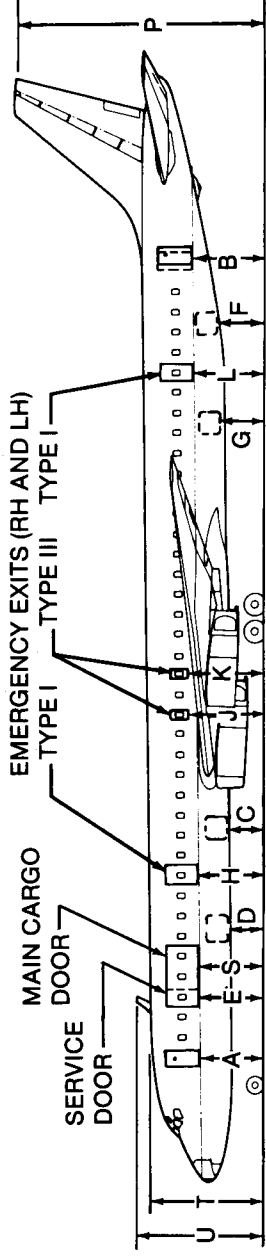

DOOR CLEARANCES ARE MEASURED TO THE JAMB AT THE CENTERLINE OF THE DOOR

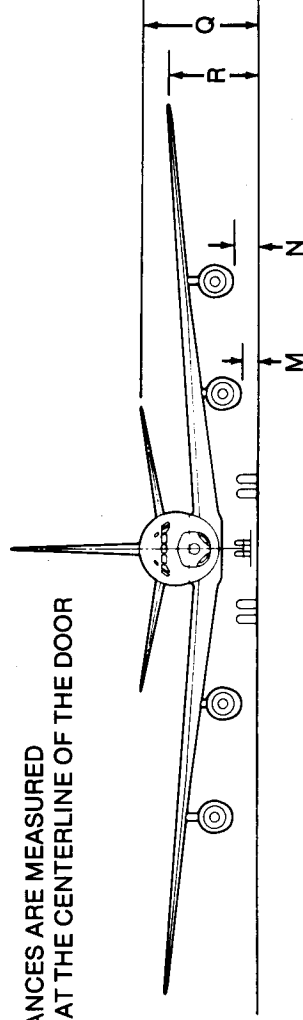

DC-8-61F, -71F

VERTICAL CLEARANCES				
	MAXIMUM		MINIMUM	
	FT - IN.	METERS	FT - IN.	METERS
A	11 - 1.3	3.39	10 - 6.4	3.21
B	13 - 1.0	3.99	12 - 1.5	3.70
C	6 - 11.4	2.19	6 - 4.6	1.95
D	6 - 9.6	2.08	6 - 2.7	1.90
E	11 - 3.0	3.43	10 - 8.1	3.25
F	8 - 1.2	2.47	7 - 3.0	2.21
G	7 - 10.3	2.40	7 - 1.6	2.17
H	11 - 5.9	3.50	10 - 11.1	3.33
J	13 - 2.4	4.02	12 - 7.7	3.85
K	13 - 3.5	4.05	12 - 8.8	3.88
L	12 - 7.7	3.85	11 - 10.1	3.61
M*	3 - 9.4	1.15	3 - 2.7	0.98
N*	5 - 1.6	1.57	4 - 7.2	1.40
P	43 - 2.3	13.16	42 - 1.0	12.82
Q	21 - 3.2	6.48	20 - 1.6	6.14
R	15 - 7.5	4.76	14 - 10.8	4.54
S	11 - 2.7	3.42	10 - 7.8	3.25
T	19 - 5.0	5.92	18 - 10.1	5.74
U	20 - 4.0	6.20	19 - 9.1	6.02

*SERIES-72F IS 10 INCHES LESS (0.25M)

IT IS RECOMMENDED THAT ± 3 INCHES BE ALLOWED FOR VERTICAL EXCURSIONS DUE TO LOADING, VARYING STRUT AND TIRE INFLATIONS, PAVEMENT UNEVENNESS, ETC.

- VALUES SHOWN ARE FOR CERTIFIED WEIGHT AND CG LIMITS SPECIFIED FOR GROUND OPERATIONS.
- VALUES APPLY TO STATIC AIRCRAFT ON A FLAT, LEVEL SURFACE.

2.3 GROUND CLEARANCE MODEL DC-8-61F, -71F

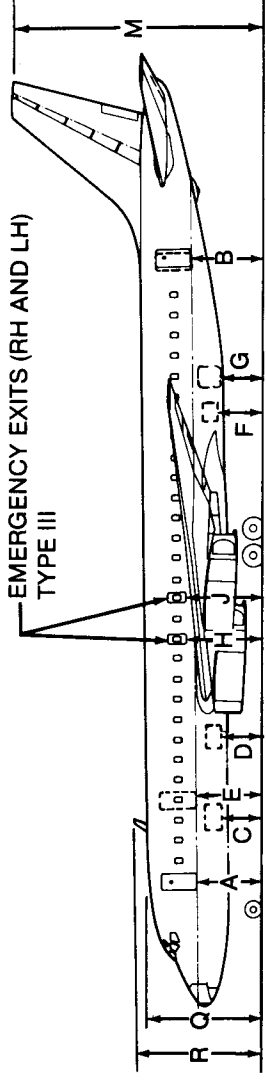

DOOR CLEARANCES ARE MEASURED TO THE JAMB
AT THE CENTERLINE OF THE DOOR

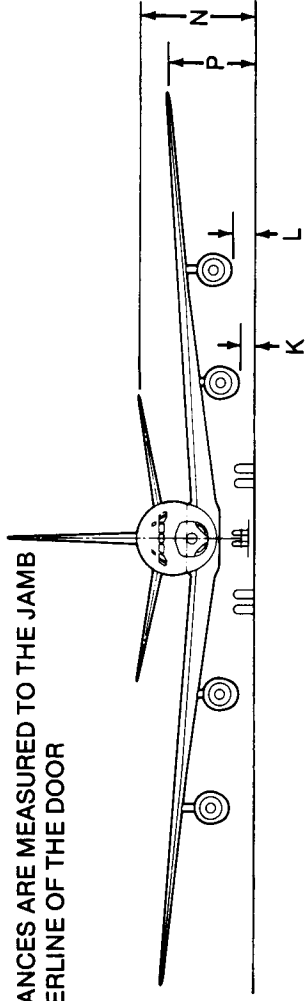

DC-8-62, -72

VERTICAL CLEARANCES			
	MAXIMUM		MINIMUM
	FT - IN.	METERS	FT - IN. METERS
A	11 - 0.5	3.37	10 - 5.8 3.20
B	13 - 0.2	13.02	12 - 2.8 3.73
C	6 - 5.6	1.97	5 - 11.1 1.81
D	6 - 9.0	2.06	6 - 2.9 1.90
E	11 - 2.6	3.42	10 - 8.1 3.25
F	7 - 8.4	2.35	7 - 1.3 2.17
G	7 - 11.2	2.42	7 - 3.4 2.22
H	13 - 0.7	3.98	12 - 6.9 3.83
J	13 - 2.0	4.01	12 - 8.4 3.87
K*	2 - 9.8	0.91	2 - 6.1 0.76
L*	4 - 8.2	1.43	4 - 2.3 1.28
M	43 - 3.0	13.18	42 - 3.6 12.89
N	21 - 4.2	6.51	20 - 4.4 6.21
P	16 - 0.7	4.89	15 - 5.1 4.70
Q	19 - 4.5	5.91	18 - 9.9 5.74
R	20 - 3.5	6.19	19 - 8.9 6.02

*SERIES-71F IS 10 INCHES LESS (0.25M)

IT IS RECOMMENDED THAT ± 3 INCHES BE ALLOWED FOR VERTICAL EXCURSIONS DUE TO LOADING, VARYING STRUT AND TIRE INFLATIONS, PAVEMENT UNEVENNESS, ETC.

- VALUES SHOWN ARE FOR CERTIFIED WEIGHT AND CG LIMITS SPECIFIED FOR GROUND OPERATIONS.
- VALUES APPLY TO STATIC AIRCRAFT ON A FLAT, LEVEL SURFACE.

2.3 GROUND CLEARANCE MODEL DC-8-62, -72

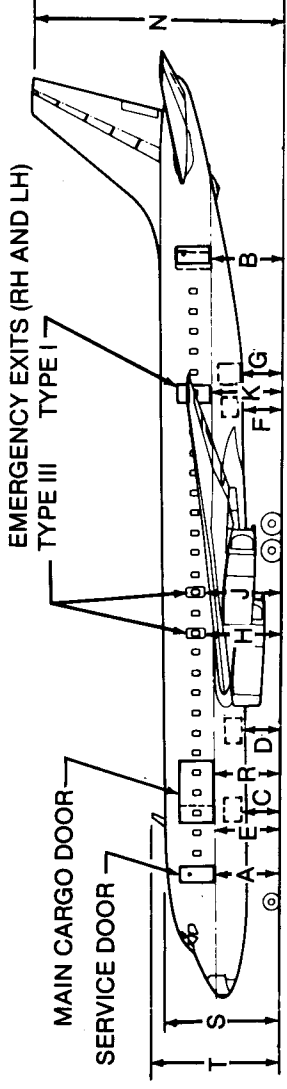

DOOR CLEARANCES ARE MEASURED TO THE JAMB AT THE CENTERLINE OF THE DOOR

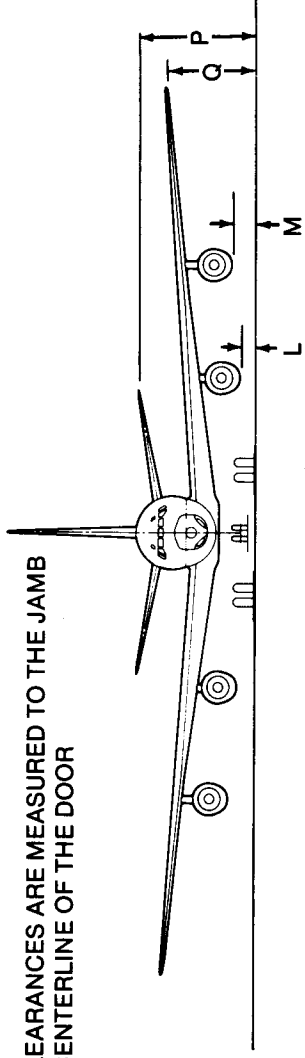

DC-8-62F, -72F

VERTICAL CLEARANCES				
	MAXIMUM		MINIMUM	
	FT - IN.	METERS	FT - IN.	METERS
A	11 - 0.7	3.37	10 - 5.7	3.19
B	13 - 0.8	3.98	12 - 2.2	3.71
C	6 - 5.8	1.98	5 - 11.0	1.80
D	6 - 10.3	2.09	6 - 3.8	1.92
E	11 - 2.8	3.42	10 - 8.1	3.25
F	7 - 8.9	2.36	7 - 0.8	2.15
G	7 - 11.4	2.43	7 - 2.8	2.20
H	13 - 1.0	3.99	12 - 6.9	3.83
J	13 - 2.3	4.02	12 - 8.4	3.87
K	12 - 6.7	3.83	11 - 10.1	3.61
* L	3 - 0.1	0.92	2 - 6.1	0.76
* M	4 - 8.6	1.44	4 - 2.2	1.28
N	43 - 3.8	13.20	42 - 3.0	12.88
P	21 - 5.1	6.53	20 - 3.8	6.19
Q	16 - 1.2	16.10	15 - 4.6	4.69
R	11 - 2.6	3.42	10 - 7.9	3.25
S	19 - 4.7	5.91	18 - 9.8	5.74
T	20 - 3.7	6.19	19 - 8.8	6.02

*SERIES-73 IS 10 INCHES LESS (0.25M)

IT IS RECOMMENDED THAT ± 3 INCHES BE ALLOWED FOR VERTICAL EXCURSIONS DUE TO LOADING, VARYING STRUT AND TIRE INFLATIONS, PAVEMENT UNEVENNESS, ETC.

- VALUES SHOWN ARE FOR CERTIFIED WEIGHT AND CG LIMITS SPECIFIED FOR GROUND OPERATIONS.
- VALUES APPLY TO STATIC AIRCRAFT ON A FLAT, LEVEL SURFACE.

2.3 GROUND CLEARANCE MODEL DC-8-62F, -72F

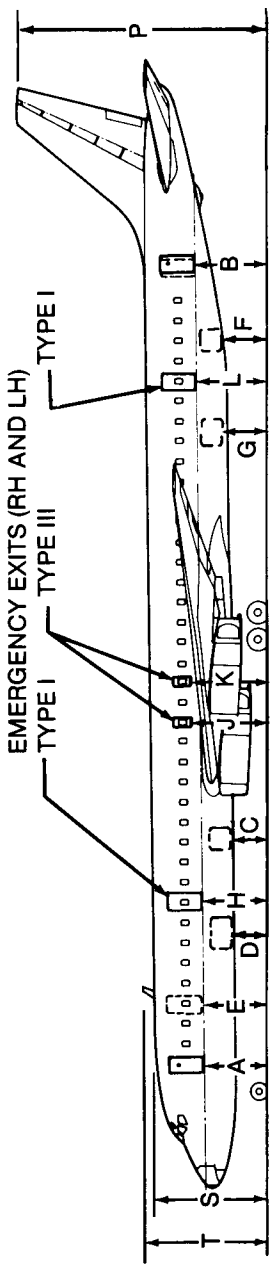

DOOR CLEARANCES ARE MEASURED TO THE JAMB
 AT THE CENTERLINE OF THE DOOR

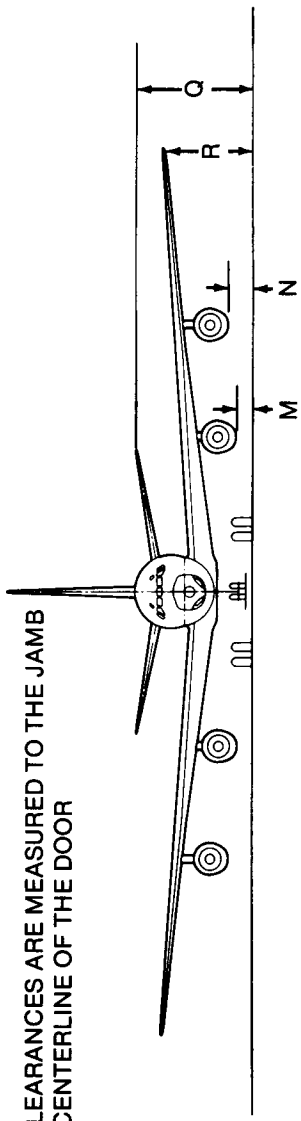

DC-8-63, -73

	VERTICAL CLEARANCES			
	MAXIMUM		MINIMUM	
	FT-IN.	METERS	FT-IN.	METERS
A	11 - 1.5	3.39	10 - 5.8	3.20
B	12 - 10.8	3.93	12 - 1.9	3.71
C	6 - 10.4	2.09	6 - 4.4	1.94
D	6 - 9.2	2.06	6 - 2.4	1.89
E	11 - 2.9	3.43	10 - 7.6	3.24
F	7 - 11.1	2.41	7 - 3.4	2.22
G	7 - 9.0	2.36	7 - 2.4	2.19
H	11 - 5.3	3.49	10 - 10.9	3.32
J	13 - 1.0	3.99	12 - 7.7	3.85
K	13 - 1.8	4.01	12 - 8.8	3.88
L	16 - 7.7	5.07	11 - 10.6	3.62
M*	2 - 11.8	0.91	2 - 6.7	0.78
N*	4 - 7.5	1.41	4 - 2.3	1.28
P	43 - 0	13.11	42 - 1.4	12.84
Q	21 - 0.9	6.42	20 - 1.9	6.14
R	15 - 10.3	4.83	15 - 3.8	4.67
S	19 - 5.1	5.92	18 - 9.7	5.73
T	20 - 4.1	6.20	19 - 8.6	6.01

*SERIES-72 IS 10 INCHES LESS (0.25M)

IT IS RECOMMENDED THAT ± 3 INCHES BE ALLOWED FOR VERTICAL EXCURSIONS DUE TO LOADING, VARYING STRUT AND TIRE INFLATIONS, PAVEMENT UNEVENNESS, ETC.

• VALUES SHOWN ARE FOR CERTIFIED WEIGHT AND CG LIMITS SPECIFIED FOR GROUND OPERATIONS.
 • VALUES APPLY TO STATIC AIRCRAFT ON A FLAT, LEVEL SURFACE.

2.3 GROUND CLEARANCE MODEL DC-8-63, -73

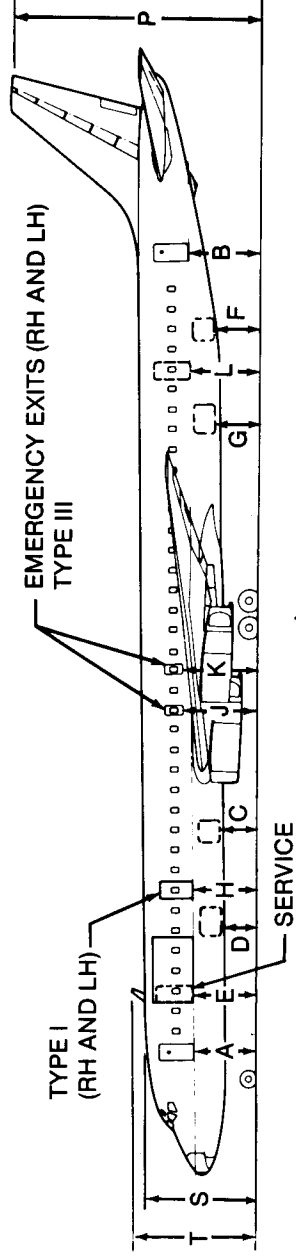

DOOR CLEARANCES ARE MEASURED TO THE JAMB AT THE CENTERLINE OF THE DOOR

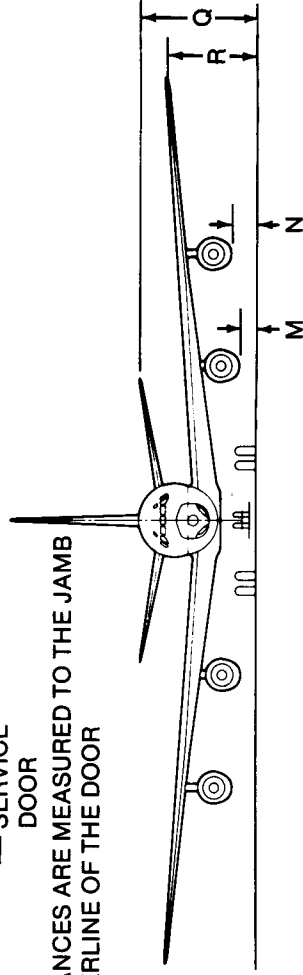

DC-8-63F, -73F

VERTICAL CLEARANCES				
	MAXIMUM		MINIMUM	
	FT - IN.	METERS	FT - IN.	METERS
A	11 - 2.3	3.41	10 - 5.8	3.20
B	13 - 0.1	3.96	12 - 1.9	3.71
C	6 - 11.3	2.12	6 - 4.4	1.94
D	6 - 10.0	2.08	6 - 2.4	1.89
E	11 - 3.7	3.45	10 - 7.6	3.24
F	8 - 0.3	2.45	7 - 3.4	2.22
G	7 - 9.5	2.37	7 - 2.0	2.18
H	11 - 6.2	3.51	10 - 10.9	3.32
J	13 - 1.9	4.01	12 - 7.7	3.85
K	13 - 2.7	4.03	12 - 8.8	3.88
L	12 - 6.9	3.83	11 - 10.6	3.62
M*	3 - 0.7	0.93	2 - 6.7	0.78
N*	4 - 8.4	1.43	4 - 2.3	1.28
P	43 - 1.5	13.14	42 - 1.4	12.84
Q	21 - 2.4	6.46	20 - 1.9	6.14
R	15 - 11.4	4.86	15 - 3.8	4.67
S	19 - 5.9	5.94	18 - 9.6	5.73
T	20 - 4.9	6.22	19 - 8.6	6.01

*SERIES-73F IS 10 INCHES LESS (0.25M)

IT IS RECOMMENDED THAT ± 3 INCHES BE ALLOWED FOR VERTICAL EXCURSIONS DUE TO LOADING, VARYING STRUT AND TIRE INFLATIONS, PAVEMENT UNEVENNESS, ETC.

• VALUES SHOWN ARE FOR CERTIFIED WEIGHT AND CG LIMITS SPECIFIED FOR GROUND OPERATIONS.

• VALUES APPLY TO STATIC AIRCRAFT ON A FLAT, LEVEL SURFACE.

2.3 GROUND CLEARANCE MODEL DC-8-63F, -73F

177 PASSENGERS 6 ABREAST SEATING
 129 SEATS ON 31 IN. (78.7 CM) PITCH
 24 SEATS ON 34 IN. (86.4 CM) PITCH
 12 SEATS ON 36 IN. (91.4 CM) PITCH
 6 SEATS ON 33 IN. (83.8 CM) PITCH
 6 SEATS ON 37 IN. (94.0 CM) PITCH

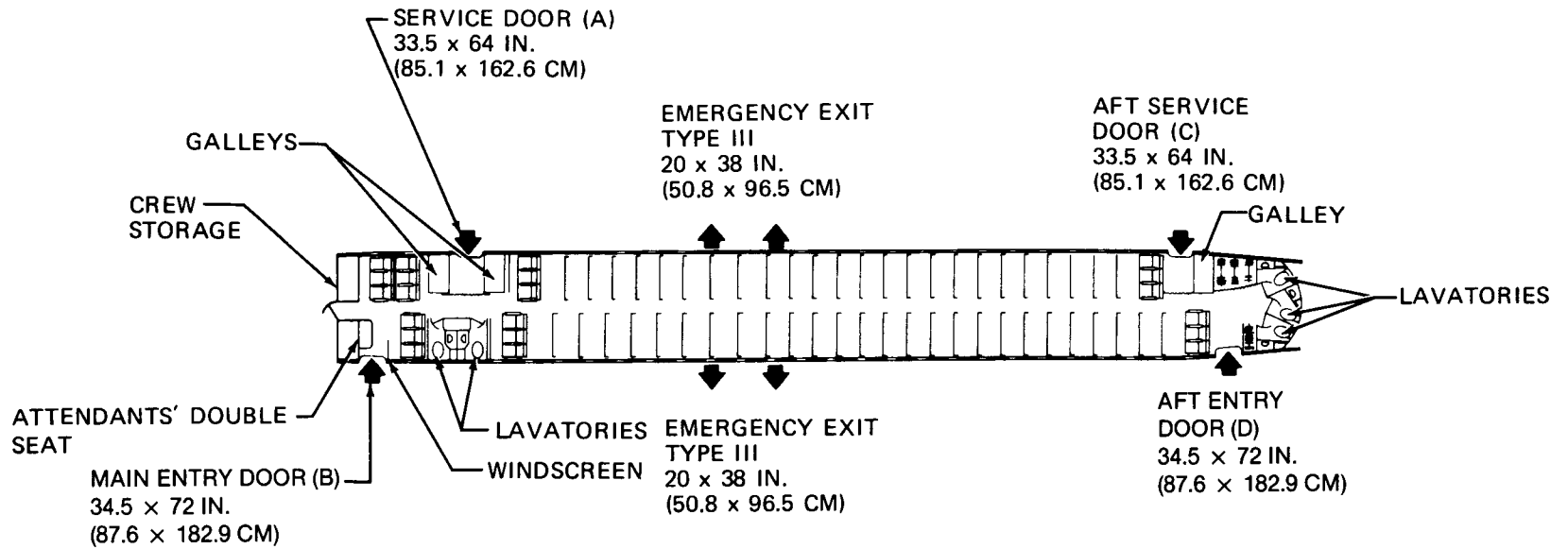

2.4 INTERIOR ARRANGEMENTS
 2.4.1 PASSENGERS
 MODEL DC-8-43

189 PASSENGERS 6 ABREAST SEATING
 66 SEATS ON 31 IN. (78.7CM) PITCH
 66 SEATS ON 32 IN. (81.3 CM) PITCH
 39 SEATS ON 39 IN. (99.1 CM) PITCH
 18 SEATS ON 40 IN. (101.6 CM) PITCH

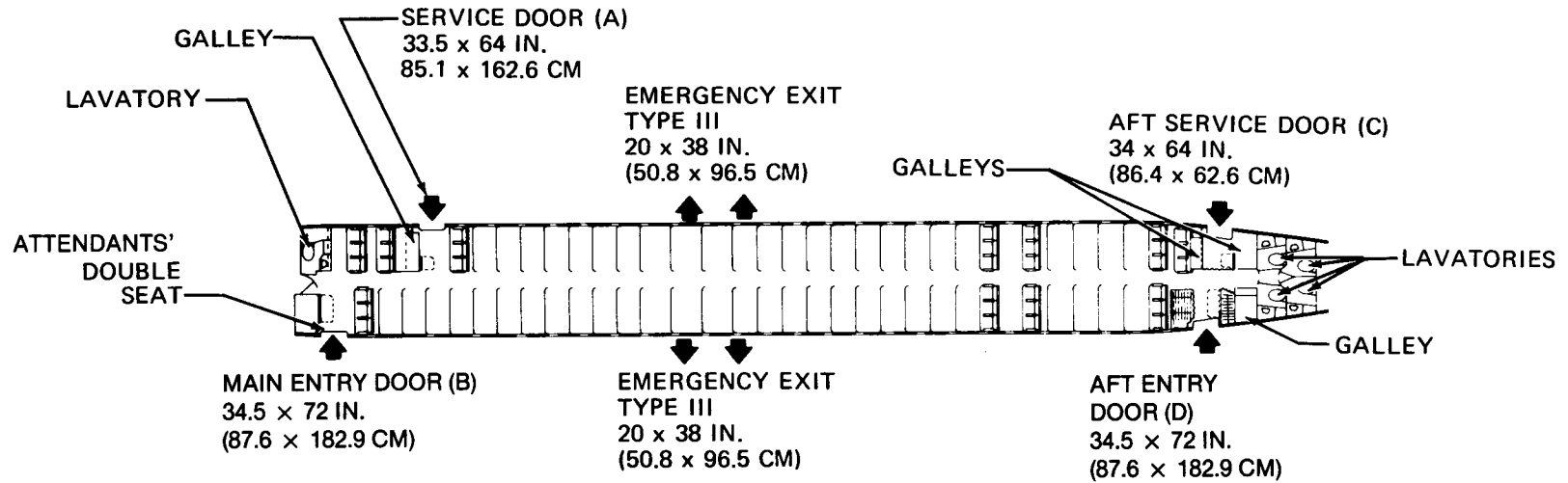

2.4 INTERIOR ARRANGEMENTS

2.4.1 PASSENGERS

MODEL DC-8-55

2.4 INTERIOR ARRANGEMENTS 2.4.1 PASSENGERS MODEL DC-8-62, -72

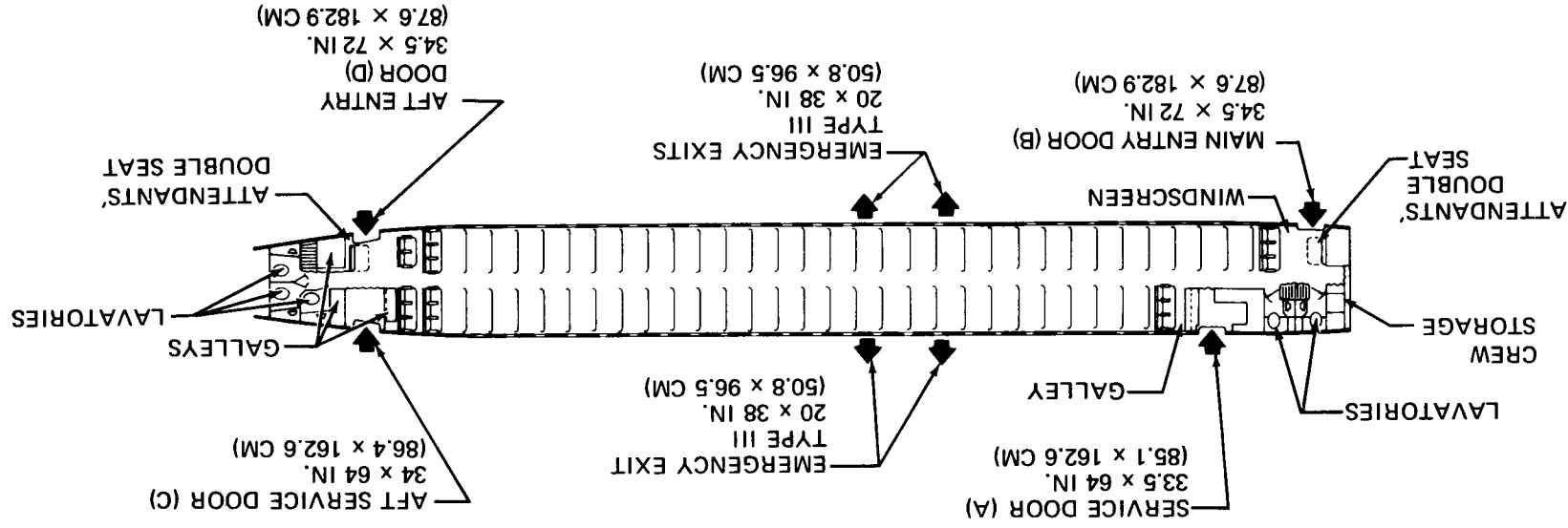

189 PASSENGERS 6 ABREAST SEATING
189 SEATS ON 34 IN. (86.4 CM) PITCH

259 PASSENGERS 6 ABREAST SEATING
 177 SEATS ON 32 IN. (81.3 CM) PITCH
 24 SEATS ON 38 IN. (96.5 CM) PITCH
 58 SEATS ON 31 IN. (78.7 CM) PITCH

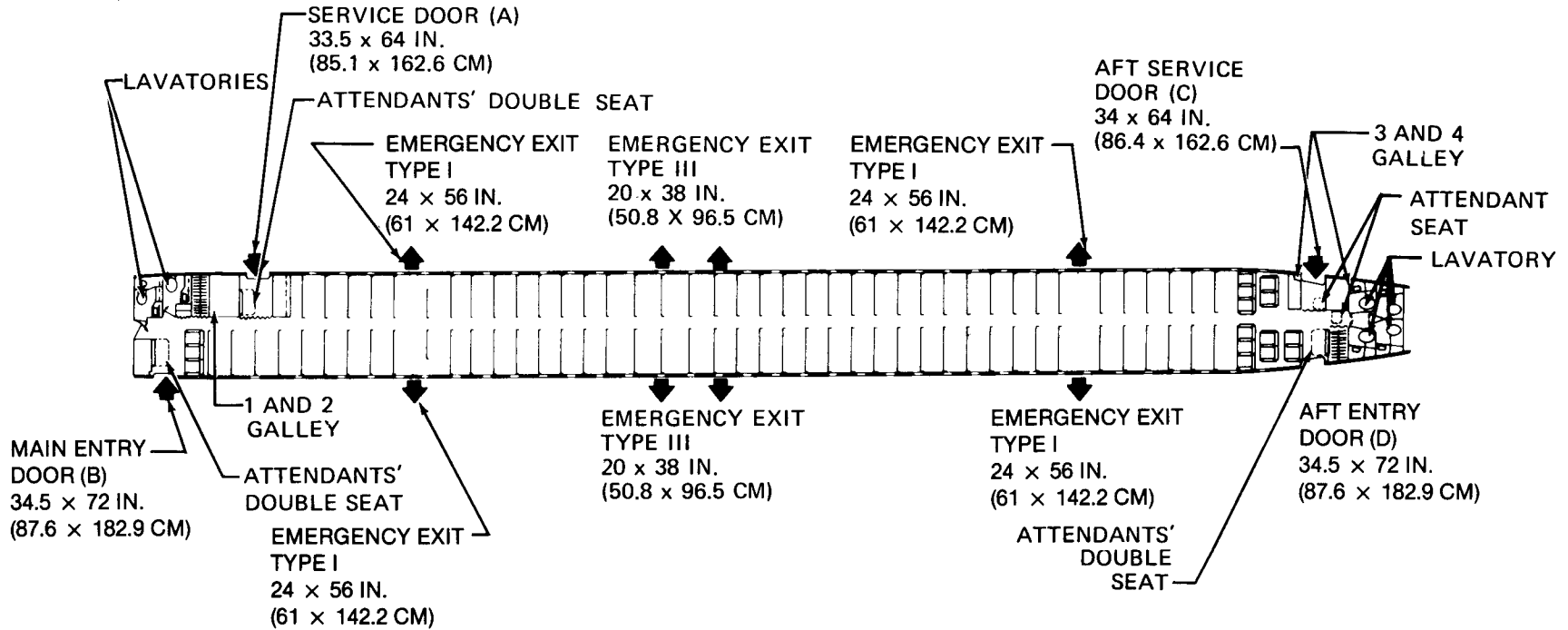

2.4 INTERIOR ARRANGEMENTS

2.4.1 PASSENGERS

MODEL DC-8-61, -63, -71, -73

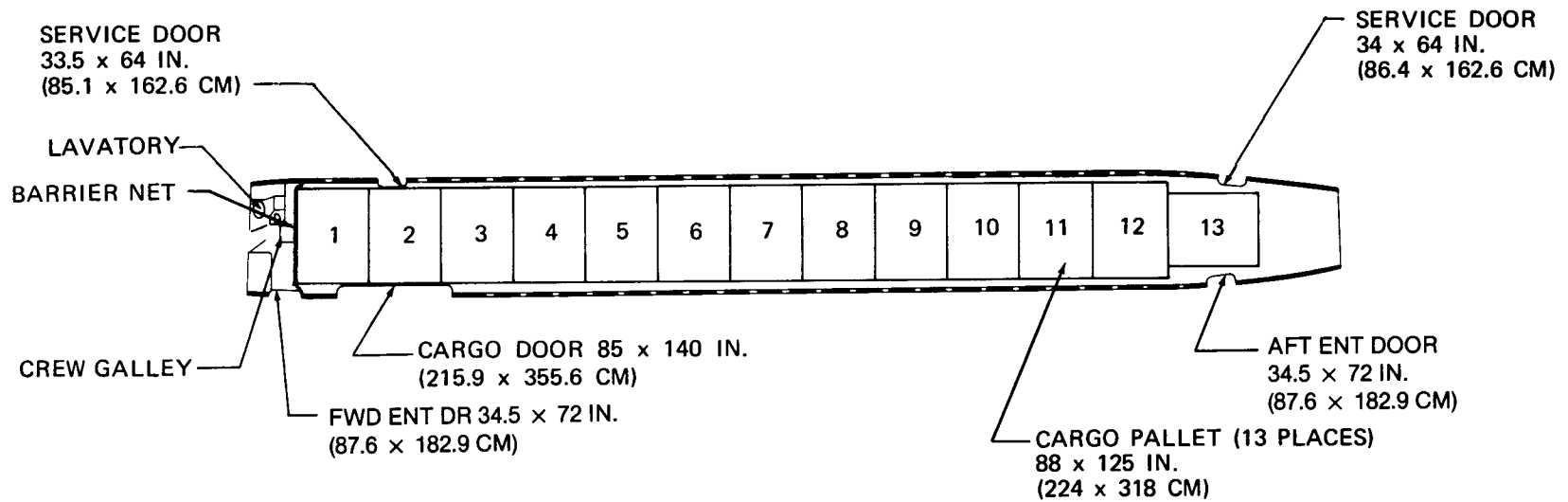

PALLETS 1 THROUGH 12	5443.2 CU FT (154.2 CU M)
PALLET 13	460 CU FT (13.03 CU M)
LOWER DECK CARGO	1390 CU FT (39.4 CU M)
TOTAL CARGO	7293.2 CU FT (206.63 CU M)

2.4 INTERIOR ARRANGEMENTS

2.4.2 CARGO

MODEL DC-8-55F

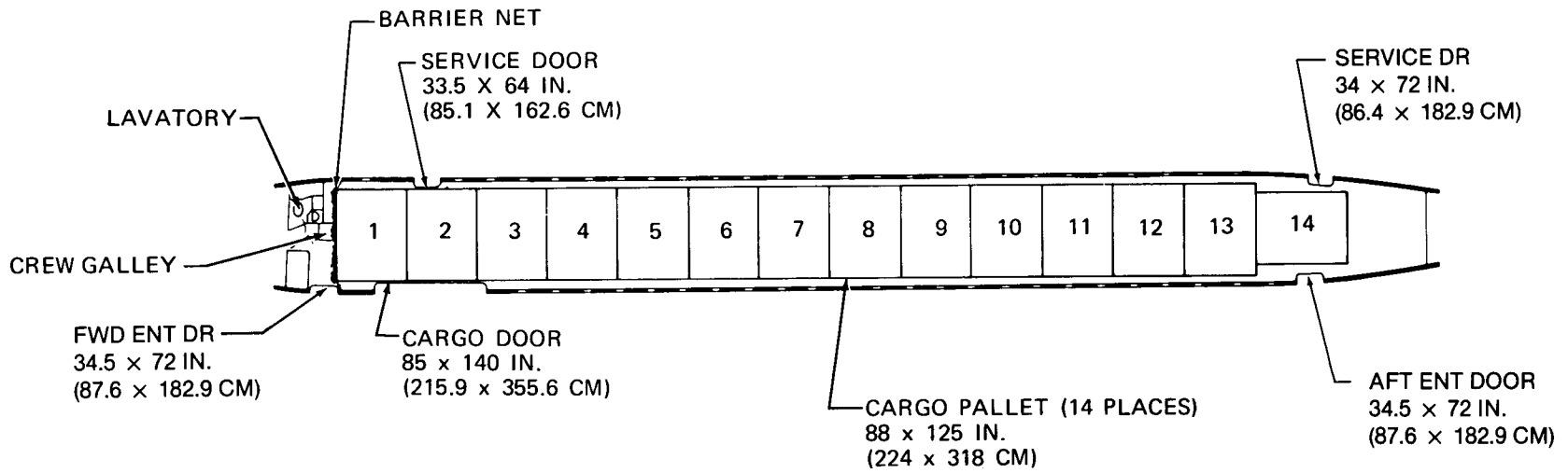

PALLETS 1 THROUGH 13	5896.8 CU FT (167 CU M)
PALLET 14	460 CU FT (13.03 CU M)
LOWER DECK CARGO	1615 CU FT (45.74 CU M)
TOTAL CARGO	7971.8 CU FT (225.77 CU M)

2.4 INTERIOR ARRANGEMENTS

2.4.2 CARGO

MODEL DC-8-62F, -72F

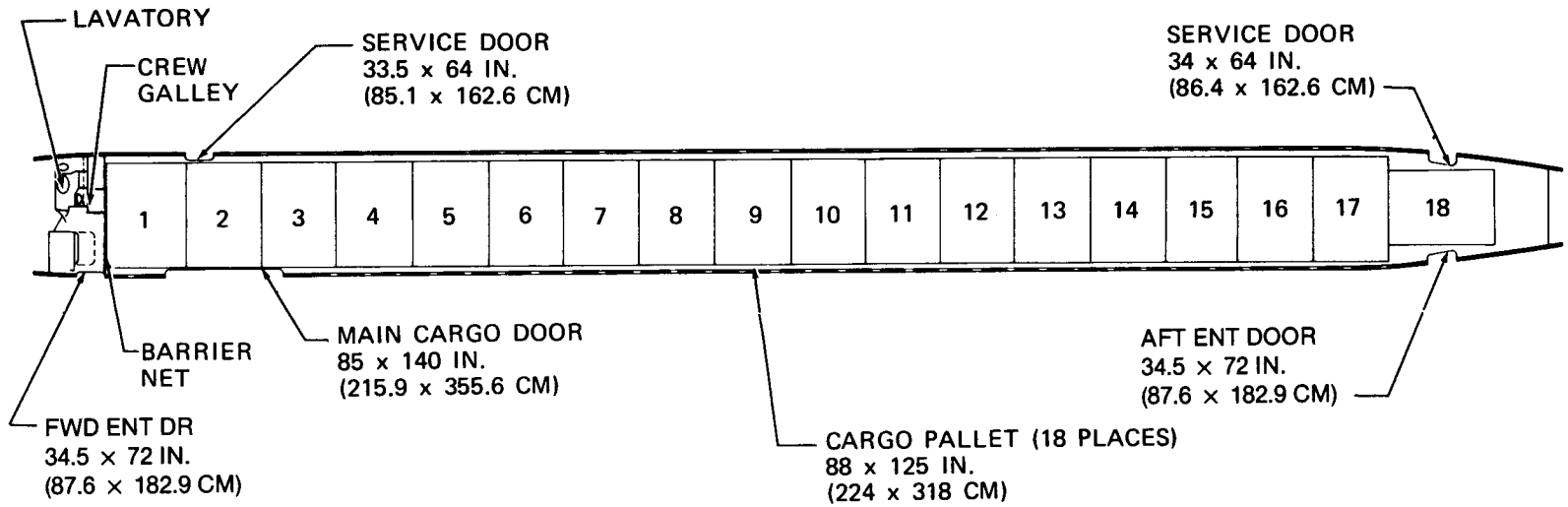

PALLETS 1 THROUGH 17	7711.2 CU FT (218.4 CU M)
PALLET 18	460 CU FT (13.03 CU M)
LOWER DECK CARGO	2500 CU FT (70.8 CU M)
TOTAL CARGO	10671.2 CU FT (302.23 CU M)

2.4 INTERIOR ARRANGEMENTS

2.4.2 CARGO

MODEL DC-8-61F, -63F, -71F, -73F

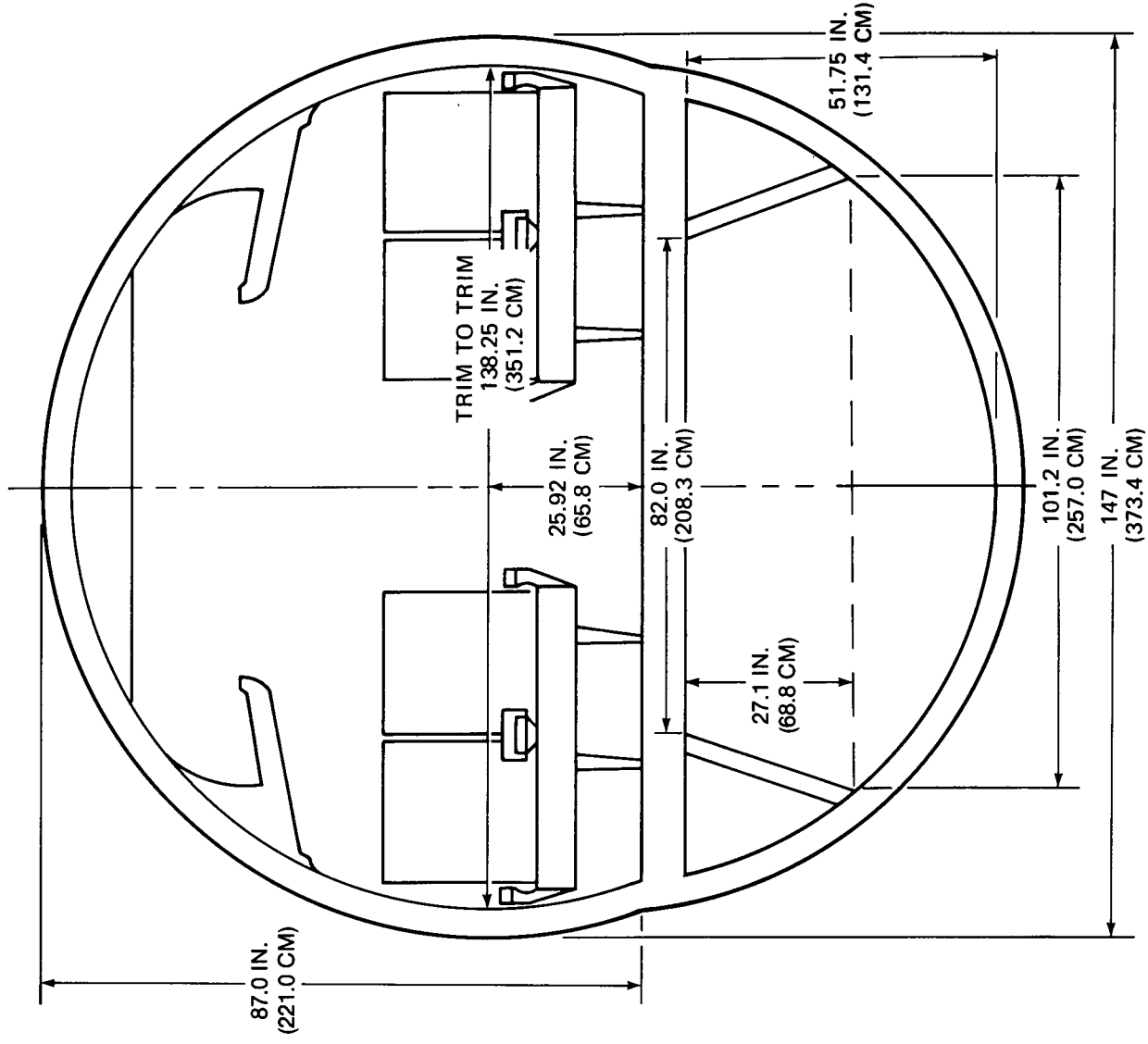

2.5 PASSENGER CABIN CROSS SECTION

2.5.1 FIRST CLASS SEATING

MODEL DC-8

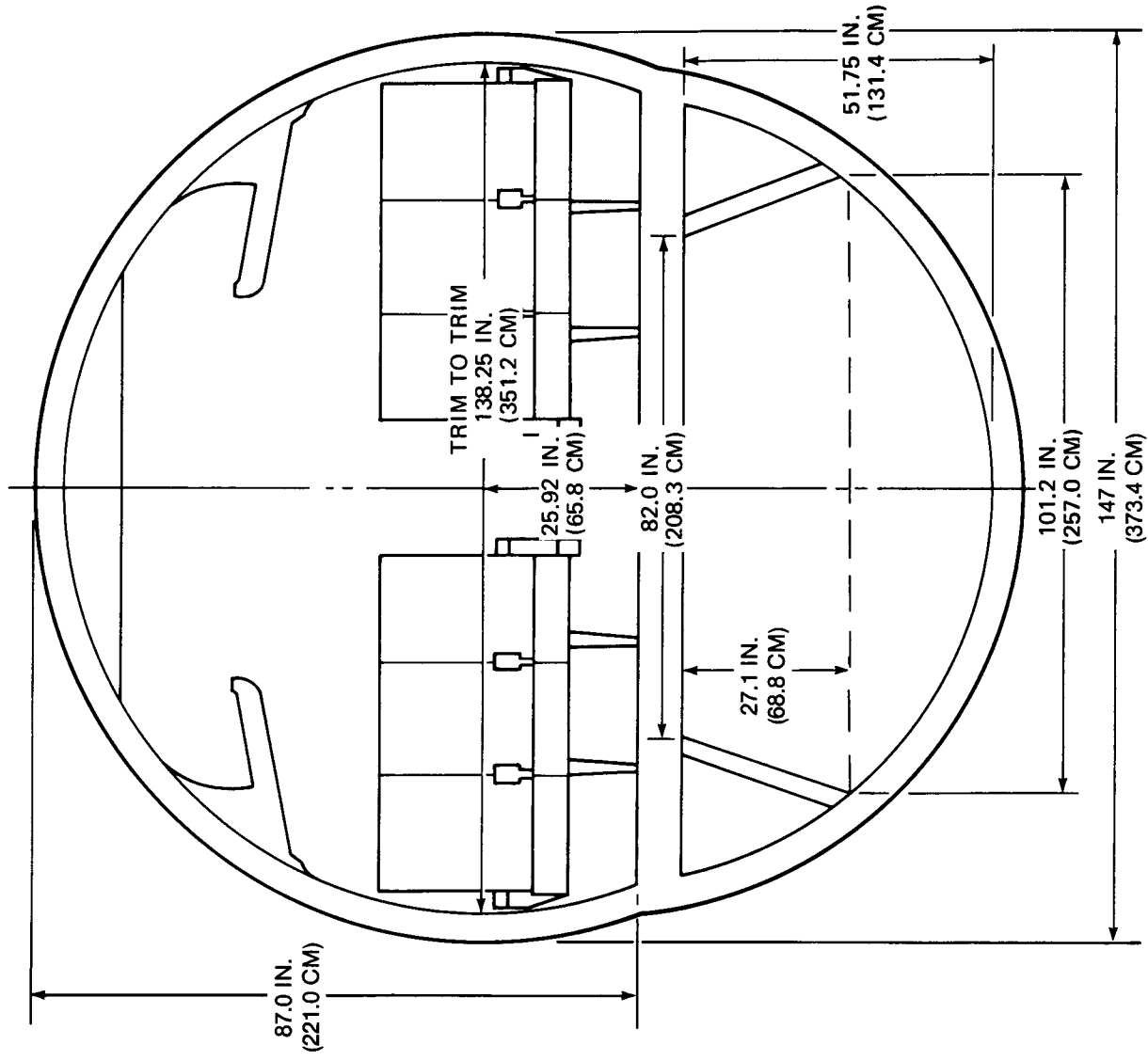

2.5 PASSENGER CABIN CROSS SECTION

2.5.2 TOURIST SEATING

MODEL DC-8

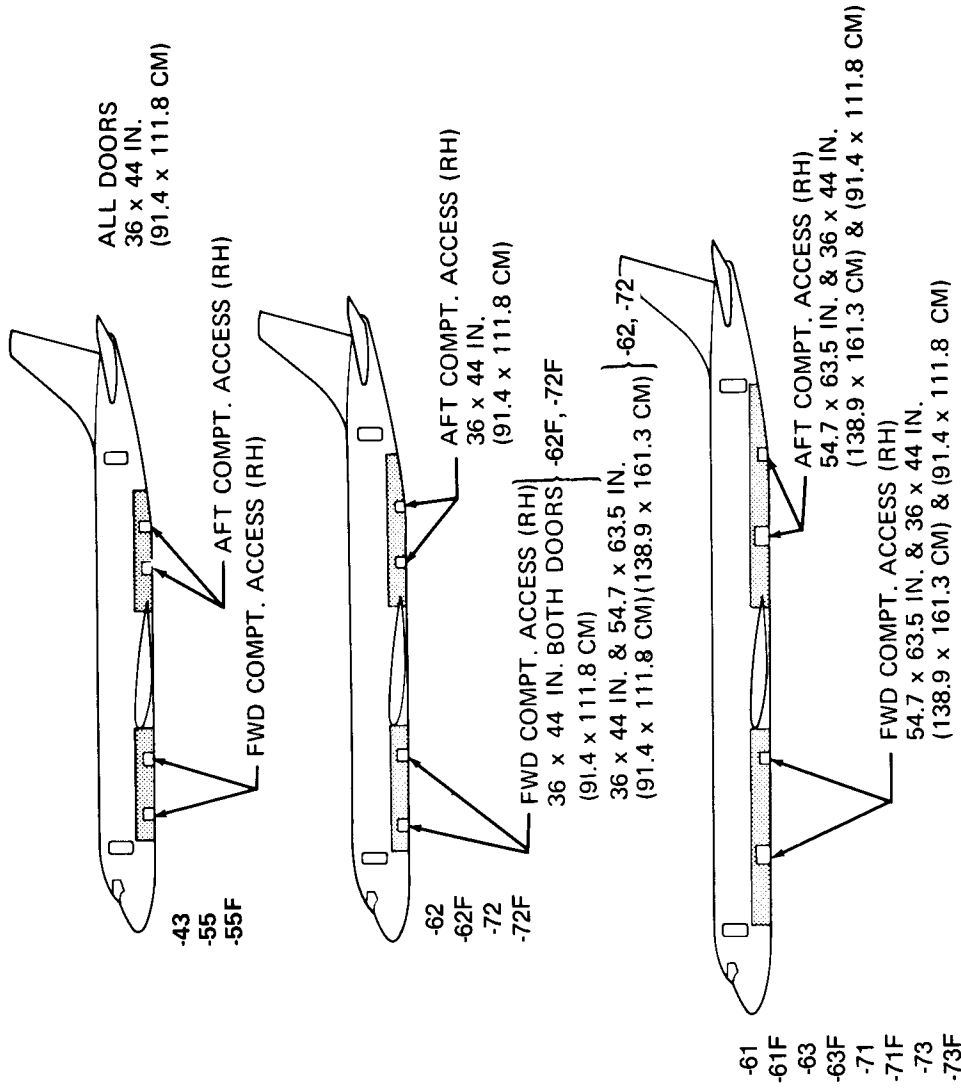

MODEL DC-8	VOLUME				TOTAL CARGO	
	FORWARD CARGO COMPARTMENT		AFT CARGO COMPARTMENT		FT ³	M ³
	FT ³	M ³	FT ³	M ³		
-43	690	19.5	700	19.8	1390	39.4
-55	690	19.5	700	19.8	1390	39.4
-55F	690	19.5	700	19.8	1390	39.4
-61, -71	1,290	36.5	1210	34.3	2500	70.8
-61F, -71F	1,290	36.5	1210	34.3	2500	70.8
-62, -72	800	22.7	815	23.1	1615	45.7
-62F, -72F	800	22.7	815	23.1	1615	45.7
-63, -73	1,290	36.5	1210	34.3	2500	70.8
-63F, -73F	1,290	36.5	1210	34.3	2500	70.8

2.6 LOWER COMPARTMENT (NO CONTAINERS) MODEL DC-8

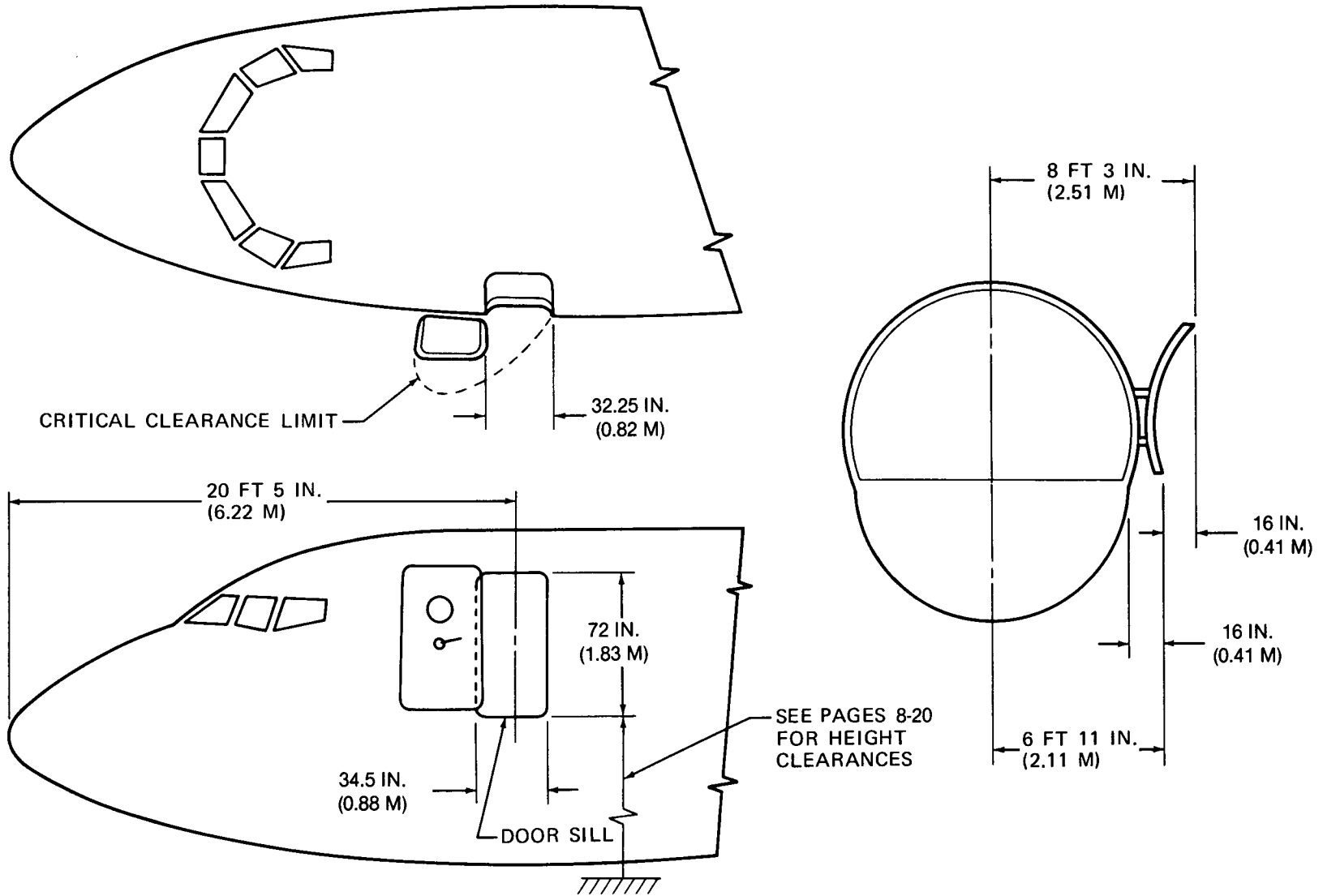

2.7 DOOR CLEARANCES
2.7.1 CLEARANCES — FORWARD PASSENGER DOOR
MODEL DC-8

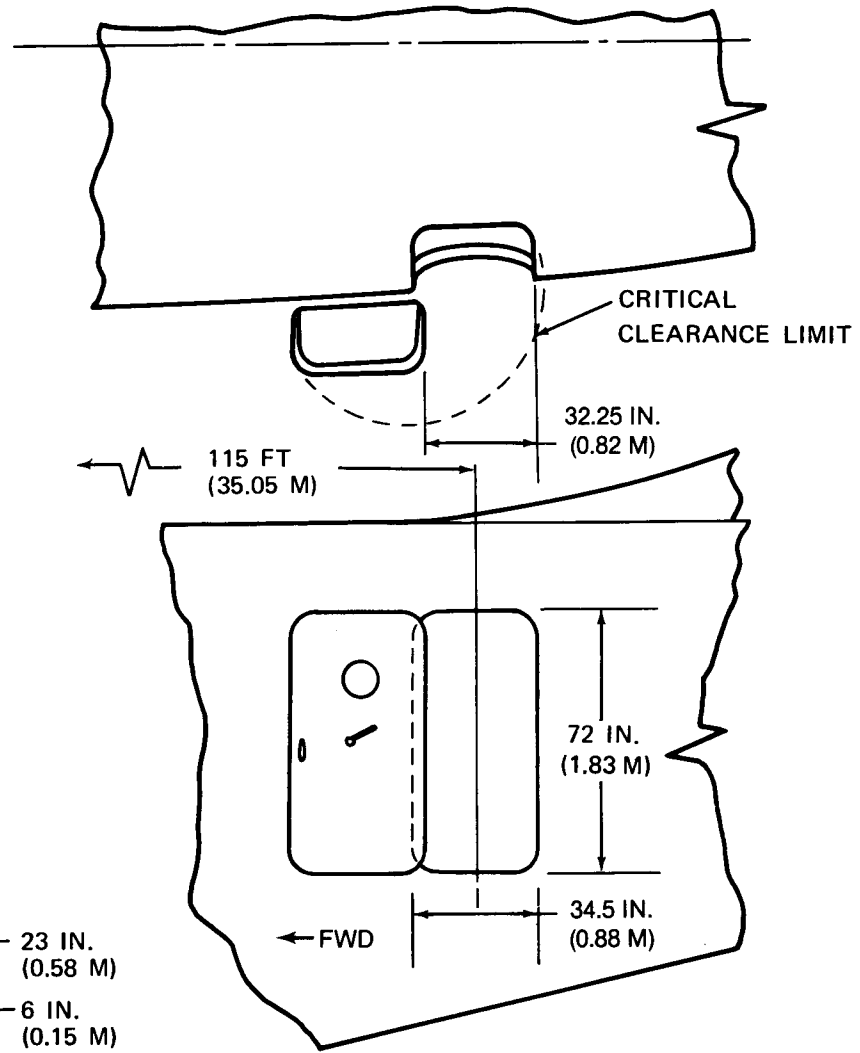
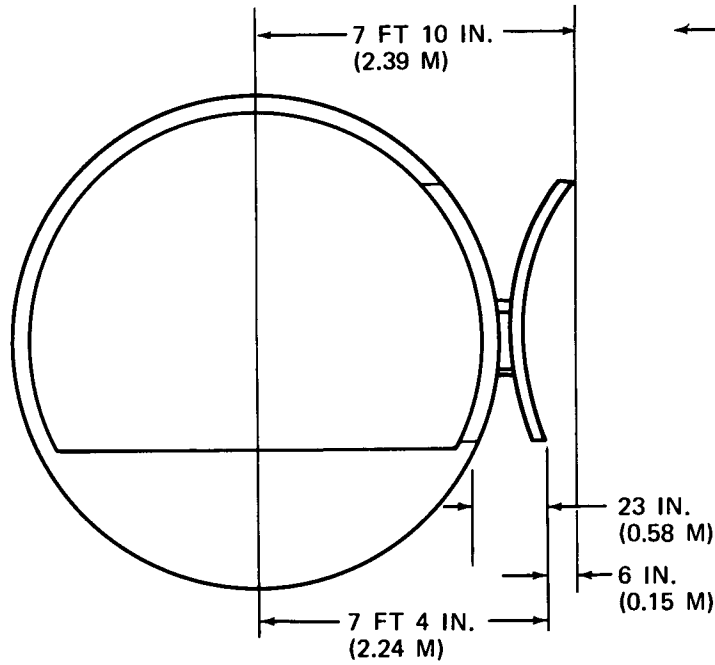

2.7 DOOR CLEARANCES

2.7.2 CLEARANCES — AFT PASSENGER DOOR

MODEL DC-8-43, -55, -55F

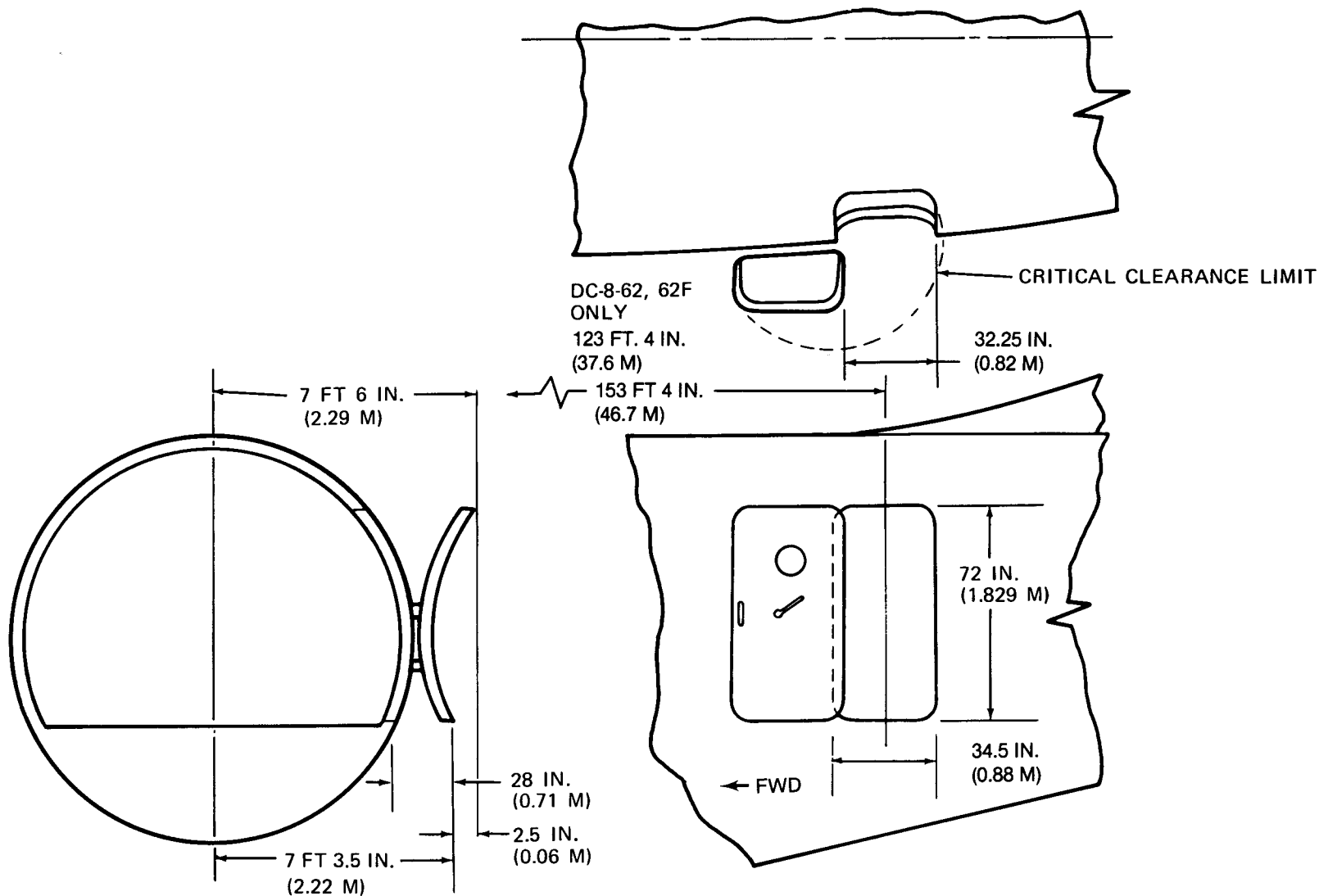

2.7 DOOR CLEARANCES

2.7.2 CLEARANCES — AFT PASSENGER DOOR
MODEL DC-8-61, -71, -61F, -71F, -62, -72,
-62F, -72F, -63, -73, -63F, -73F

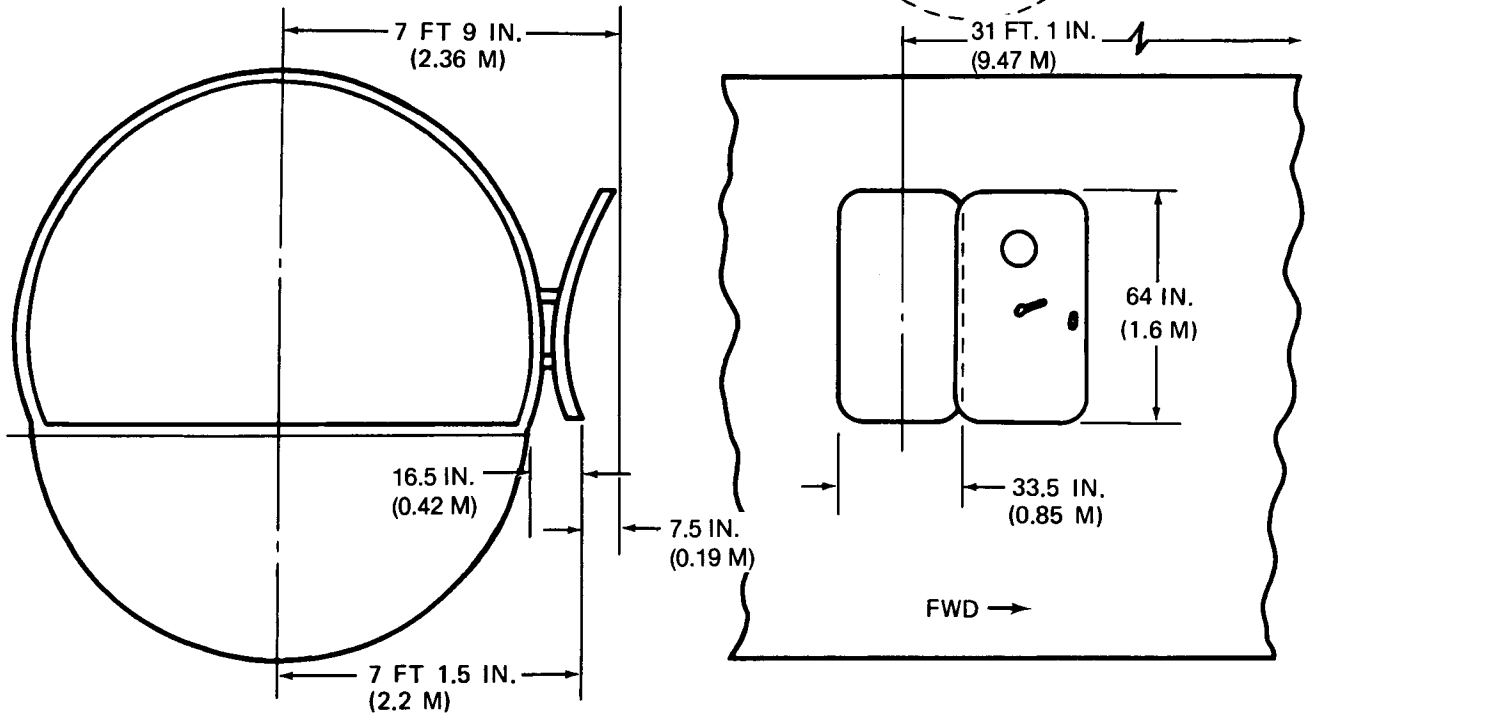

2.7 DOOR CLEARANCES

2.7.3 CLEARANCES — FORWARD BUFFET DOOR

MODEL DC-8-43, -55, -55F

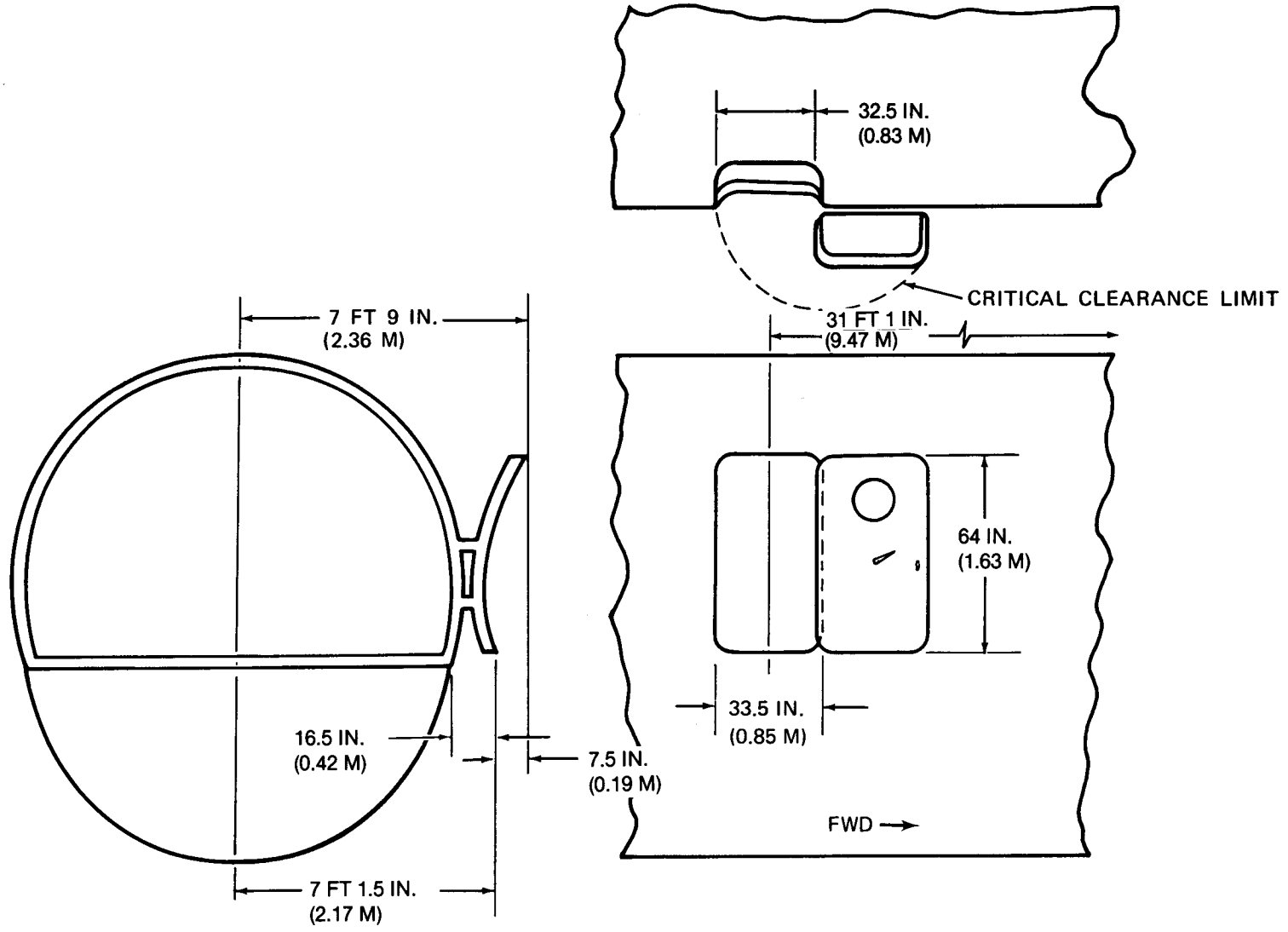

2.7 DOOR CLEARANCES
2.7.3 CLEARANCES — FORWARD BUFFET DOOR
 MODEL DC-8-61, -71, -61F, -71F, -62, -72, -62F,
 -72F, -63, -73, -63F, -73F

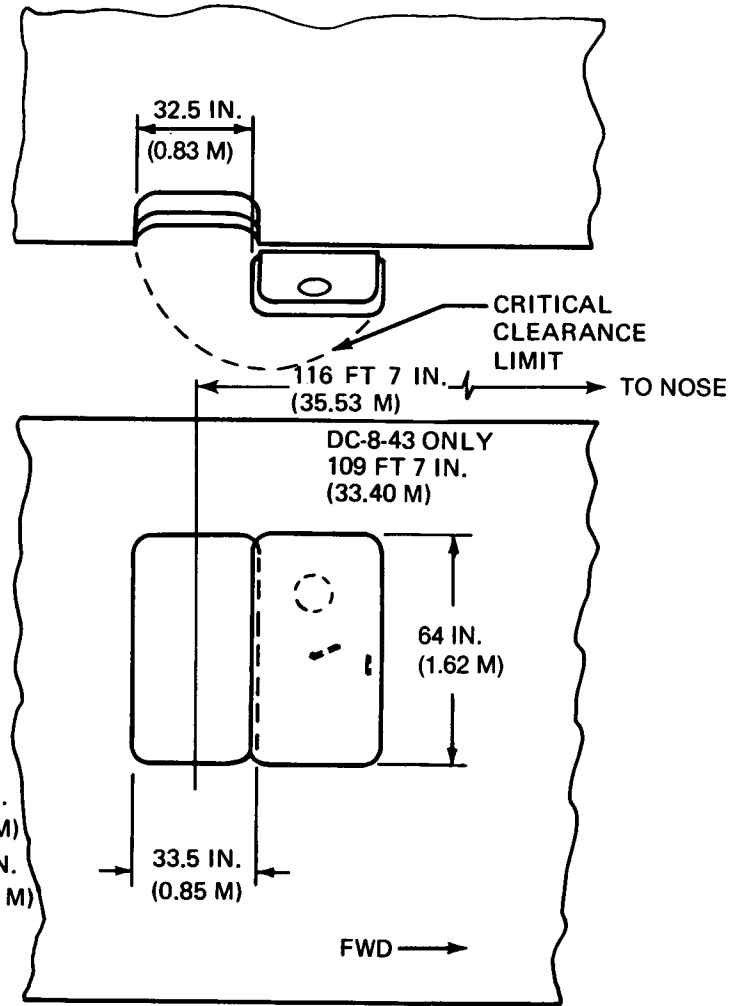
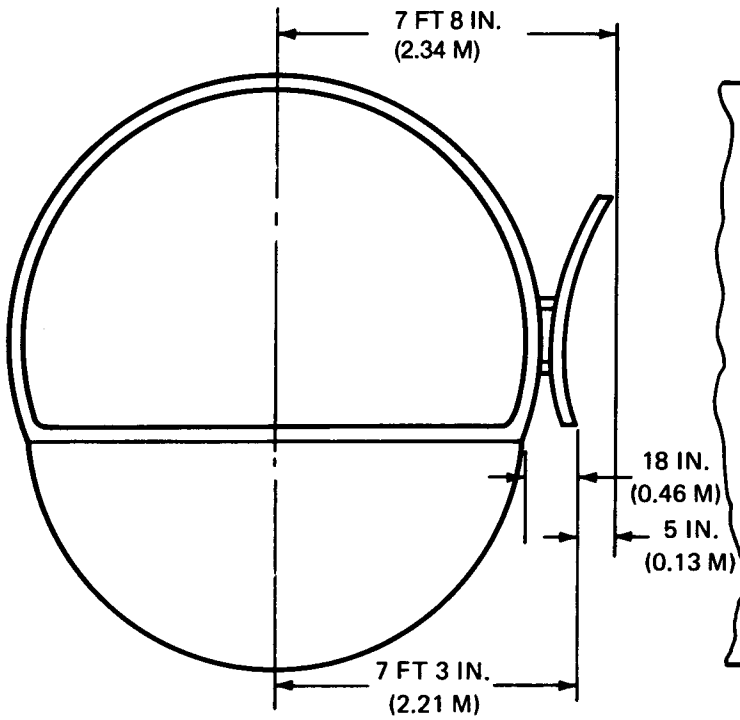

2.7 DOOR CLEARANCES
 2.7.4 CLEARANCES — AFT BUFFET DOOR
 MODEL DC-8-43, -55, -55F

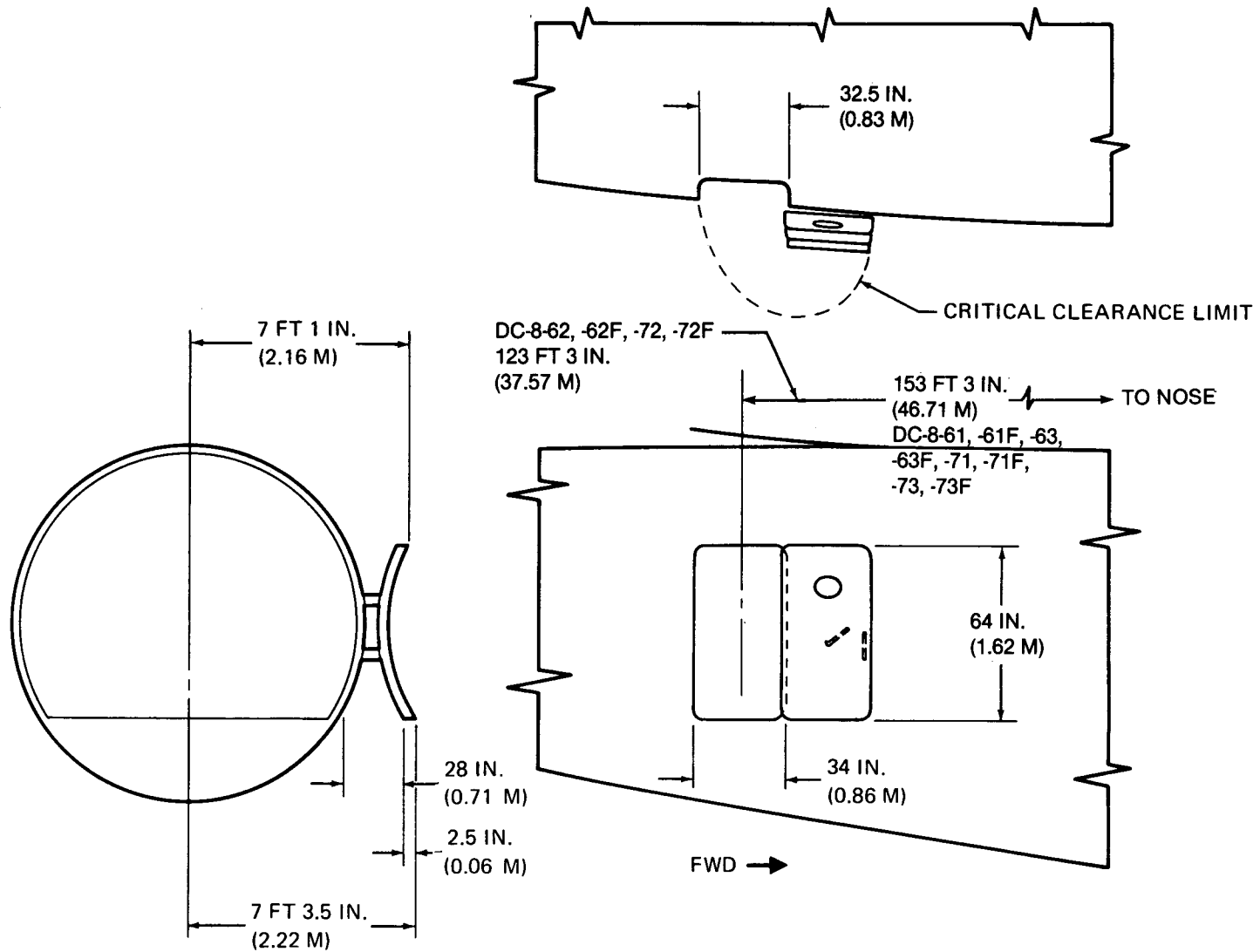

2.7 DOOR CLEARANCES

2.7.4 CLEARANCES — AFT BUFFET DOOR

MODEL DC-8-61, -71, -61F, -71F, -62, -72,
-62F, -72F, -63, -73, -63F, -73F

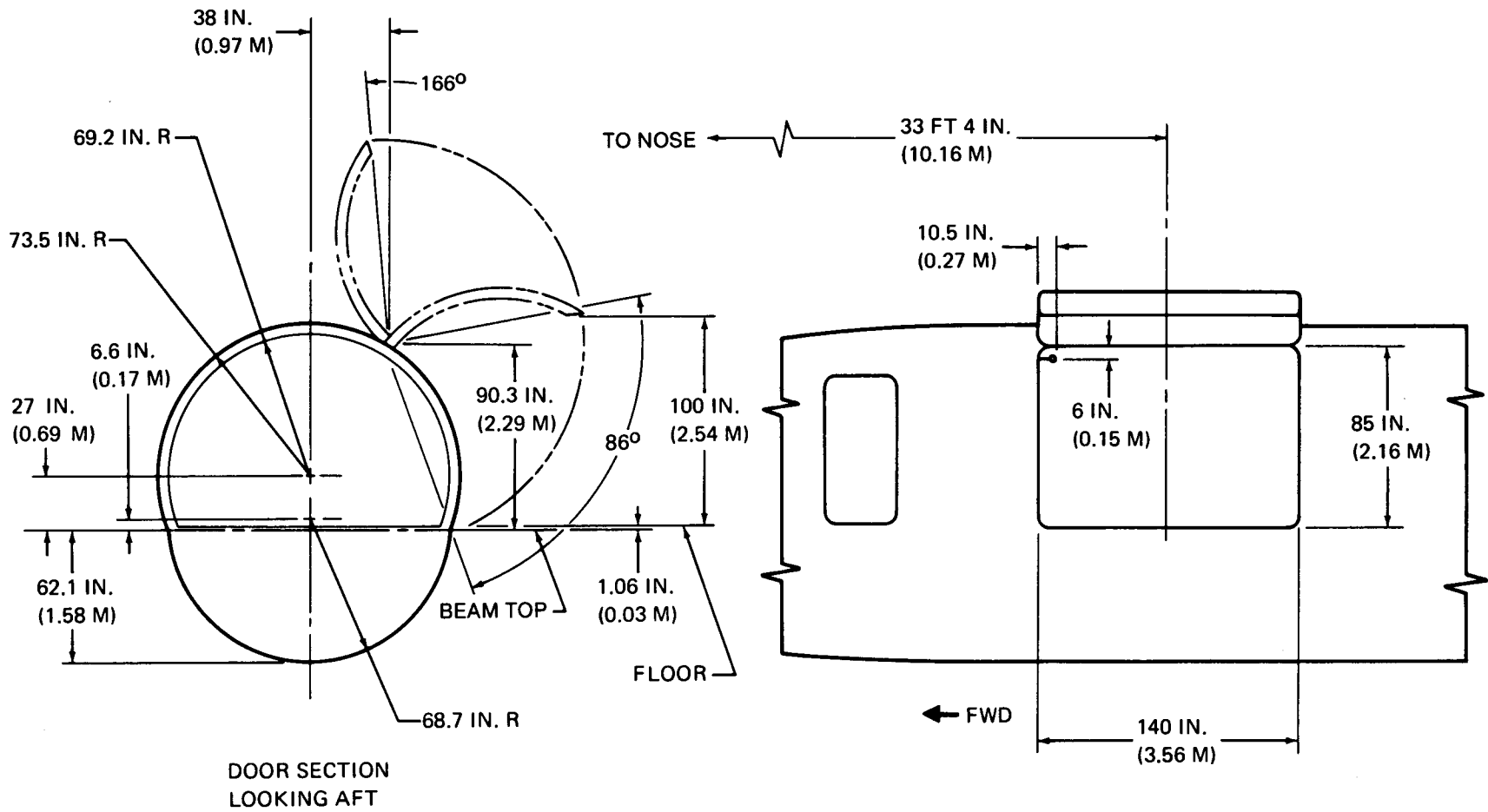

2.7 DOOR CLEARANCES

2.7.5 CLEARANCES — MAIN CARGO DOOR

MODEL DC-8-55F, -61F, -62F, -63F, -71F, -72F, -73F

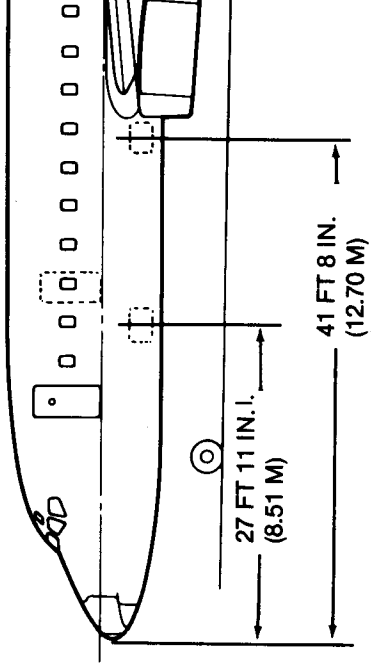

FORWARD BAGGAGE DOORS

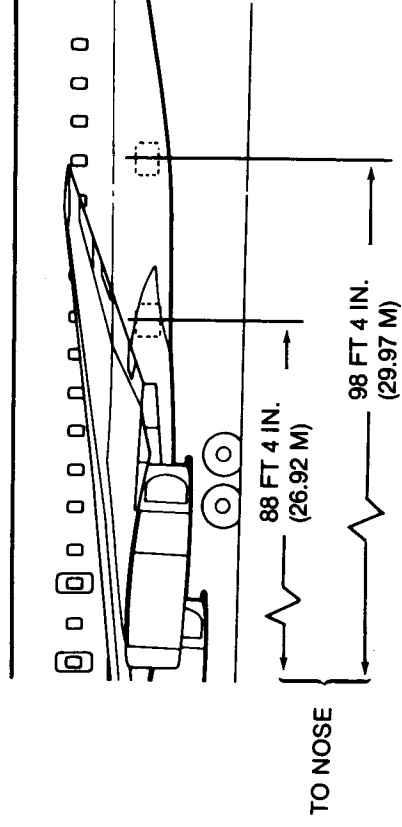

AFT BAGGAGE DOORS

2.7 DOOR CLEARANCES
2.7.6 CLEARANCES — BAGGAGE DOORS
MODEL DC-8-43, -55, -55F

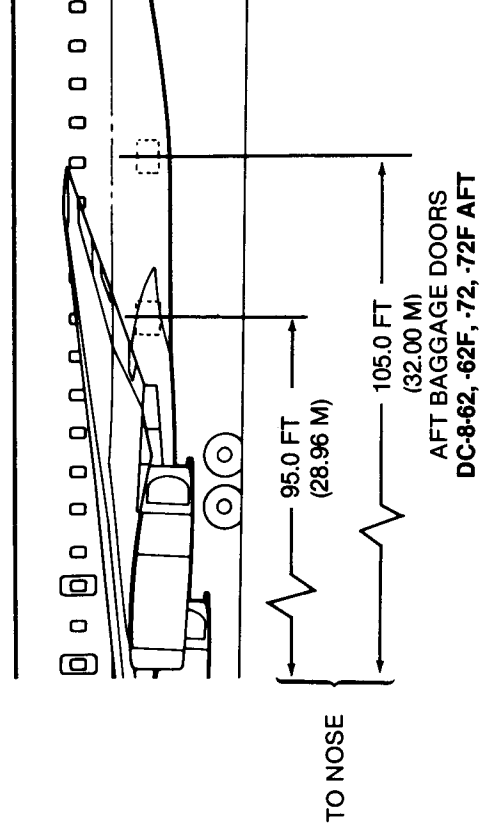
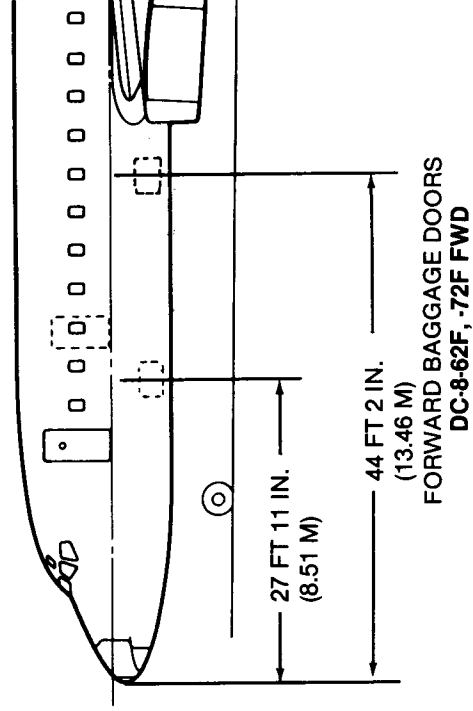
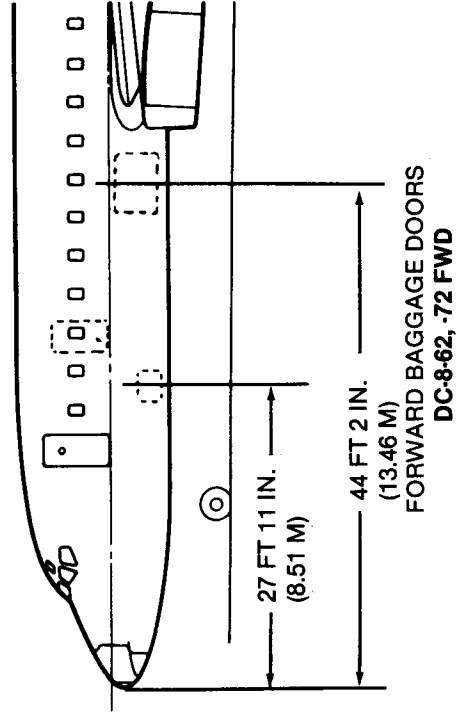

2.7 DOOR CLEARANCES

2.7.6 CLEARANCES — BAGGAGE DOORS

MODEL DC-8-62, -62F, -72, -72F

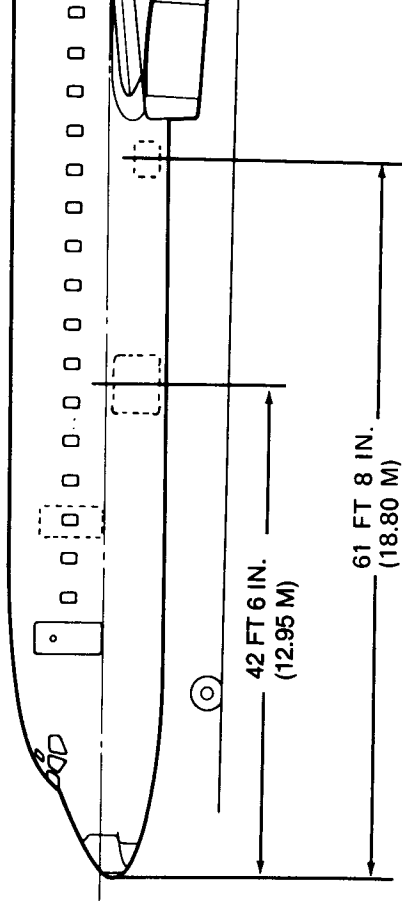

FORWARD BAGGAGE DOORS

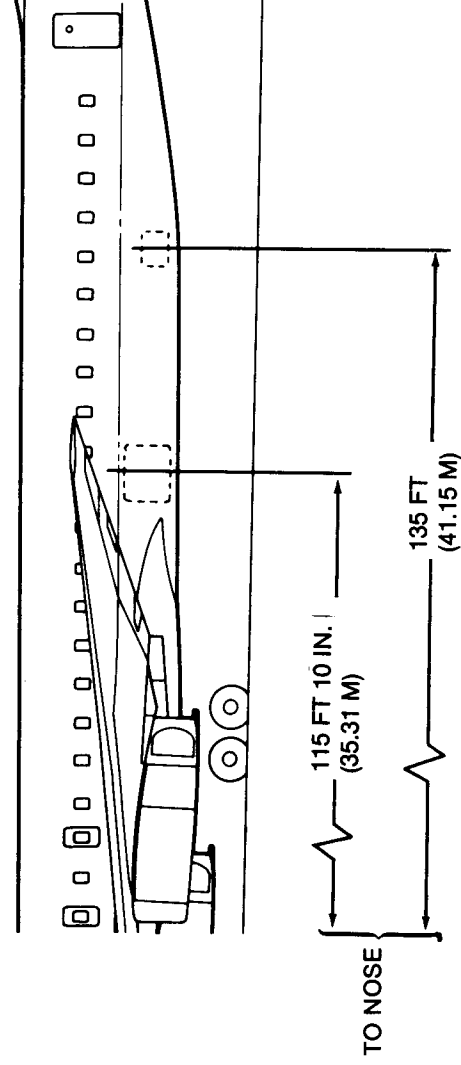

AFT BAGGAGE DOORS

2.7 DOOR CLEARANCES
2.7.6 CLEARANCES — BAGGAGE DOORS
MODEL DC-8-61, -71, -61F, -71F, -63, -73, -63F, -73F

COMPT	DOOR	A		B	
		IN.	M	IN.	M
FWD	FWD	24.75	0.63	25.5	0.65
	AFT	24.75	0.63	25.5	0.65
AFT	FWD	24.75	0.63	25.5	0.65
	AFT	20.0	0.51	22.0	0.56

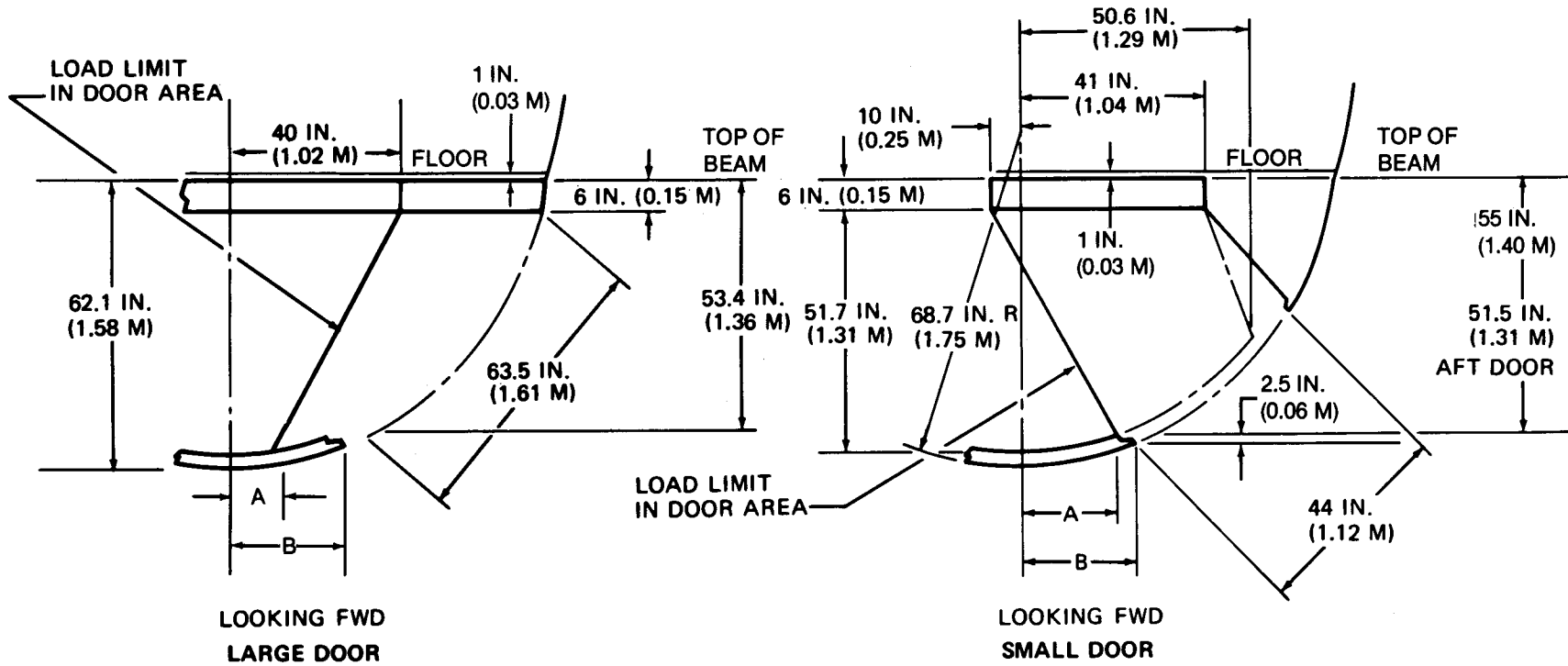

2.7 DOOR CLEARANCES

2.7.7 CLEARANCES BAGGAGE DOORS — FWD — AFT MODEL DC-8-43, -55, -55F

COMPT	DOOR	A		B	
		IN.	M	IN.	M
FWD	FWD	20	0.51	24.7	0.63
	AFT	8	0.20	28	0.71
AFT	FWD	20	0.51	24.7	0.63
	AFT	13	0.33	20.0	0.51

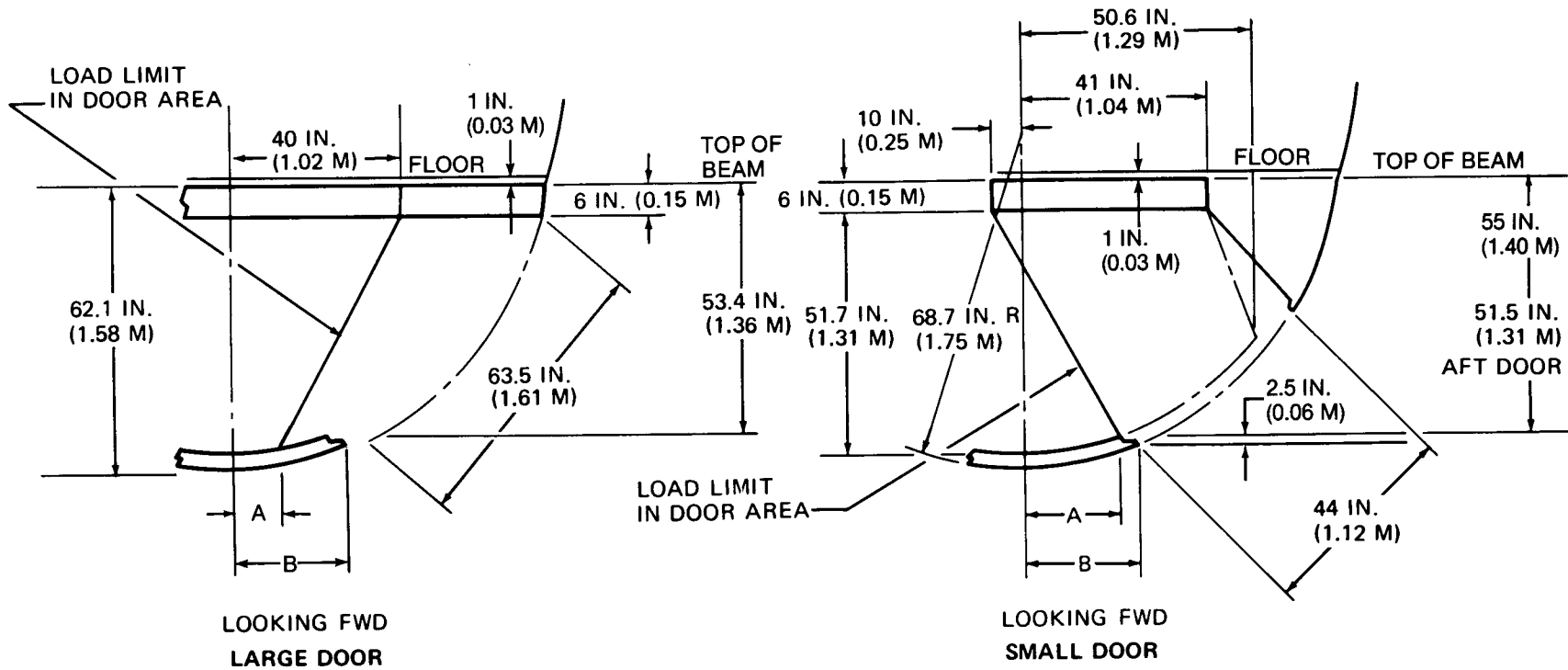

2.7 DOOR CLEARANCES

2.7.7 CLEARANCES BAGGAGE DOORS — FWD — AFT MODEL DC-8-62, -72, -62F, -72F

3.0 AIRPLANE PERFORMANCE

3.1 General Information

Pages 46 through 69 present payload-range information for a specific long-range cruise altitude and at the fuel reserve condition shown.

Pages 70 through 86 represent FAR takeoff and landing field length requirements for FAA certification.

Standard day temperatures for the altitudes shown are tabulated below:

ELEVATION		STANDARD DAY TEMP	
FEET	METERS	°F	°C
0	0	59	15
2,000	610	51.9	11.6
4,000	1,220	44.7	7.1
6,000	1,830	37.6	3.1
8,000	2,440	30.5	- 0.8

Where it is necessary to qualify the data used in the curves with respect to engine type and performance characteristics, an appropriate note is added at the position indicated. Similarly, each plot of data should be qualified as to the temperature condition.

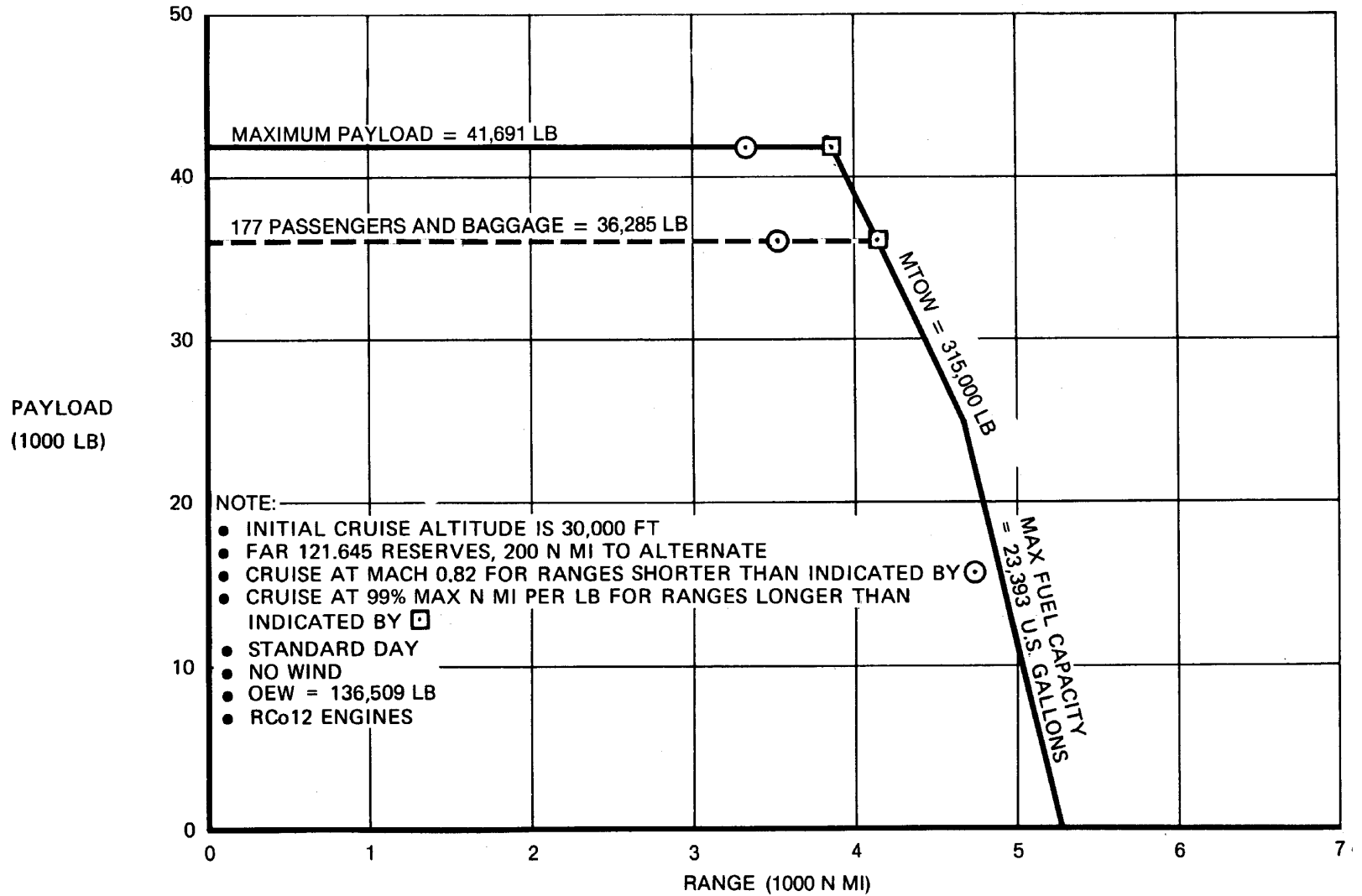

3.2 PAYLOAD/RANGE

3.2.1 PAYLOAD-RANGE CAPABILITIES FOR STEP ALTITUDE CRUISE (U.S. UNITS) MODEL DC-8-43

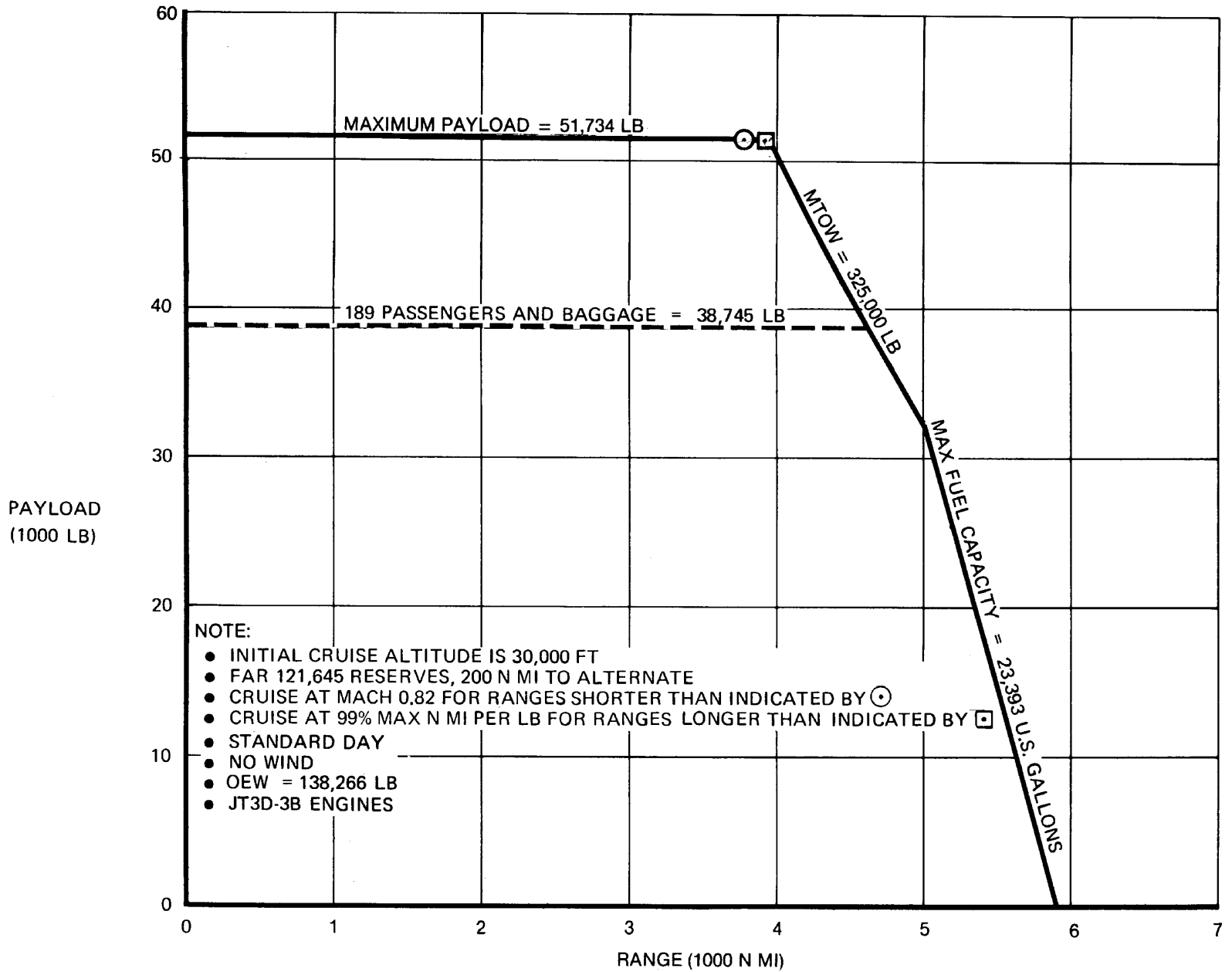

3.2 PAYLOAD/RANGE

3.2.1 PAYLOAD-RANGE CAPABILITIES FOR STEP ALTITUDE CRUISE (U.S. UNITS)

MODEL DC-8-55

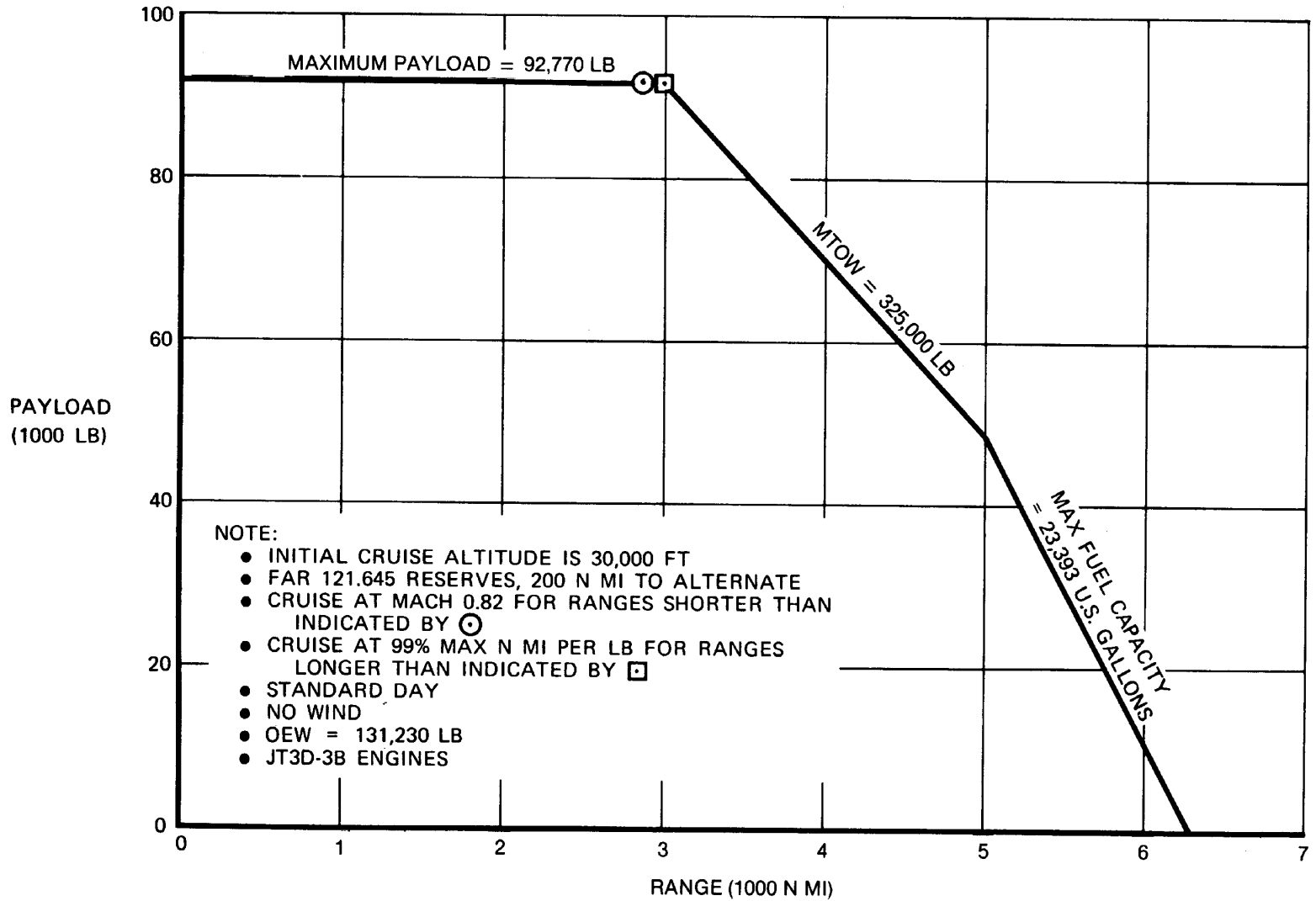

3.2 PAYLOAD/RANGE

3.2.1 PAYLOAD-RANGE CAPABILITIES FOR STEP ALTITUDE CRUISE (U.S. UNITS)

MODEL DC-8-55F

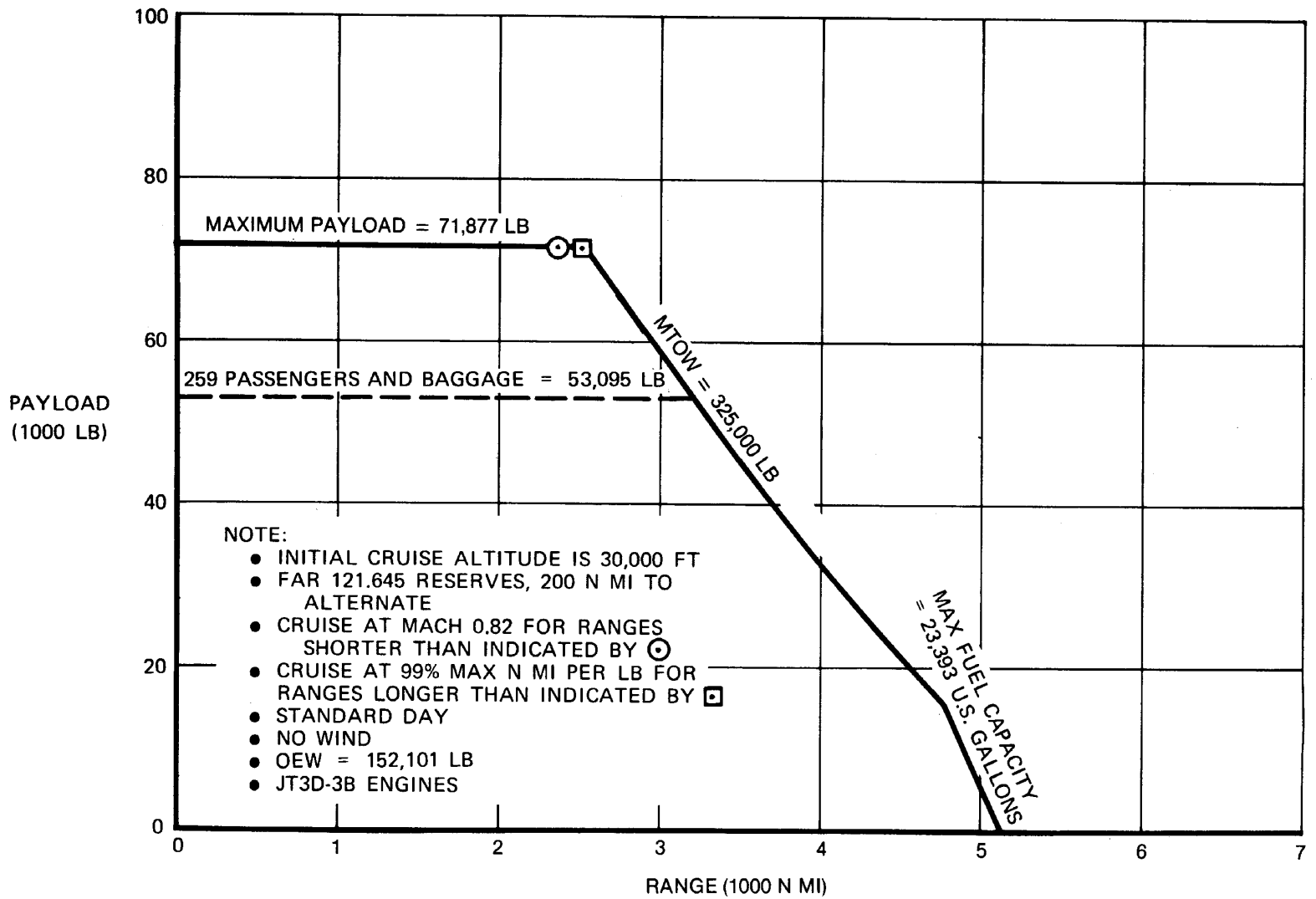

3.2 PAYLOAD/RANGE

3.2.1 PAYLOAD-RANGE CAPABILITIES FOR STEP ALTITUDE CRUISE (U.S. UNITS) MODEL DC-8-61

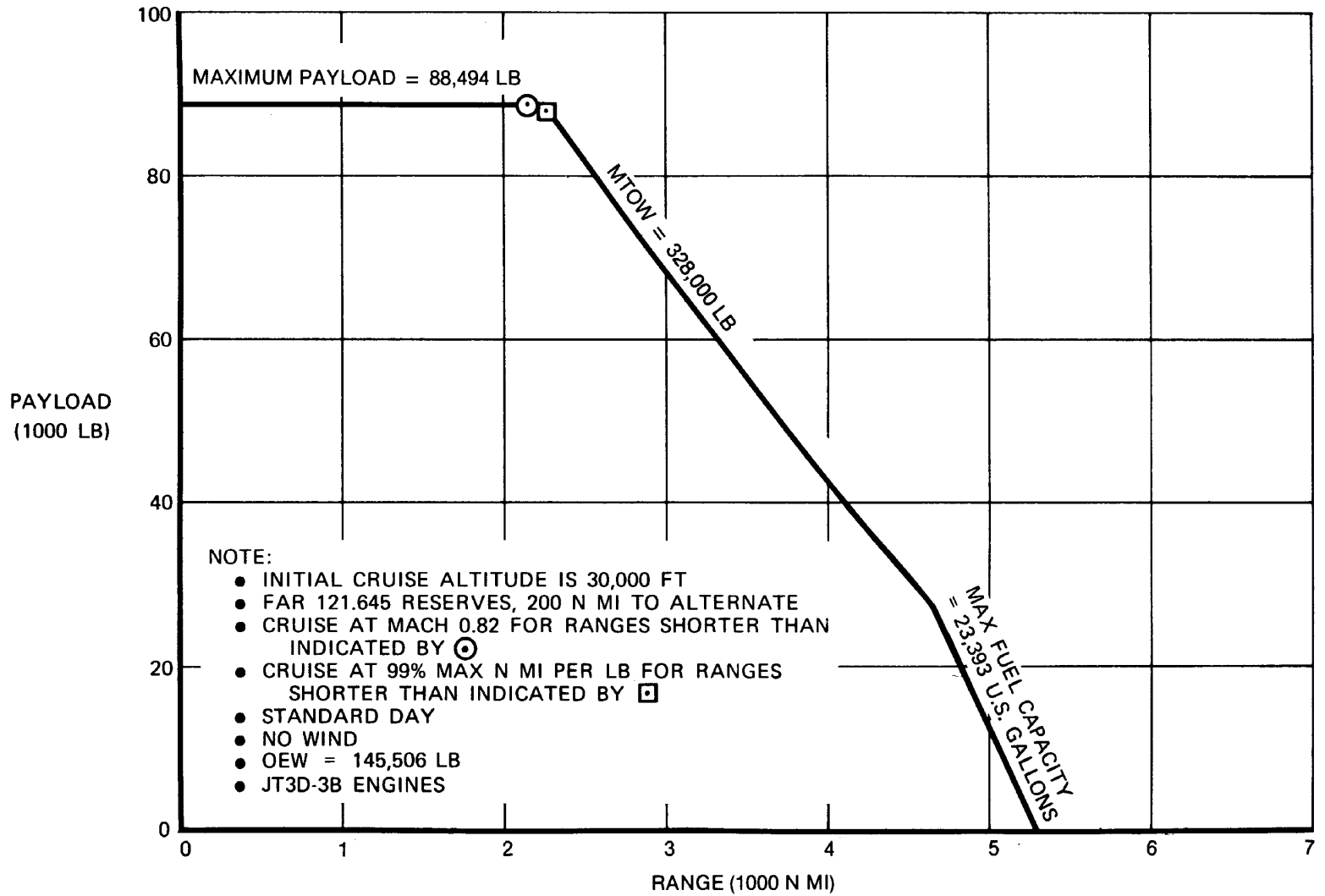

3.2 PAYLOAD/RANGE

3.2.1 PAYLOAD-RANGE CAPABILITIES FOR STEP ALTITUDE CRUISE (U.S. UNITS)

MODEL DC-8-61F

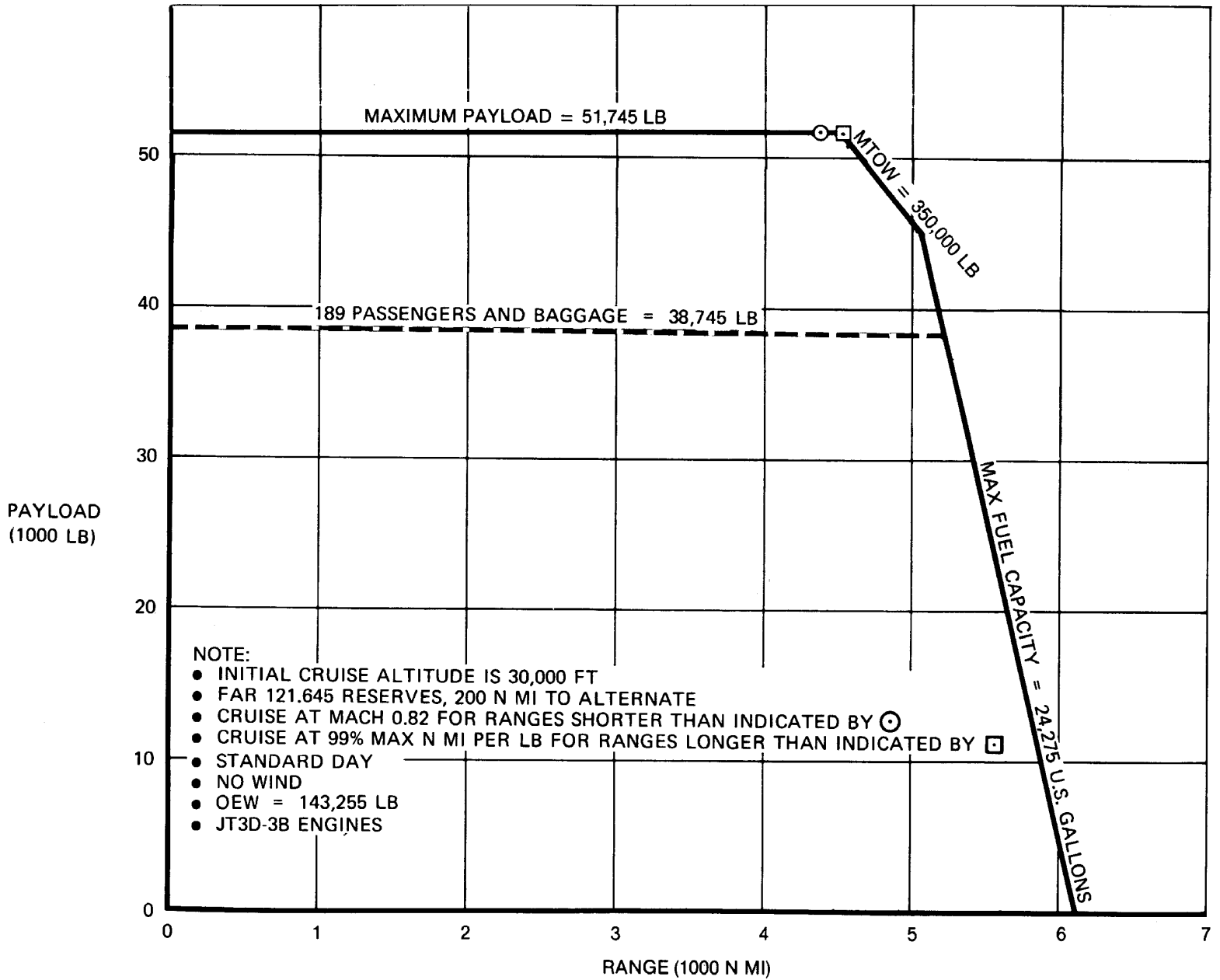

3.2 PAYLOAD/RANGE

3.2.1 PAYLOAD-RANGE CAPABILITIES FOR STEP ALTITUDE CRUISE (U.S. UNITS) MODEL DC-8-62

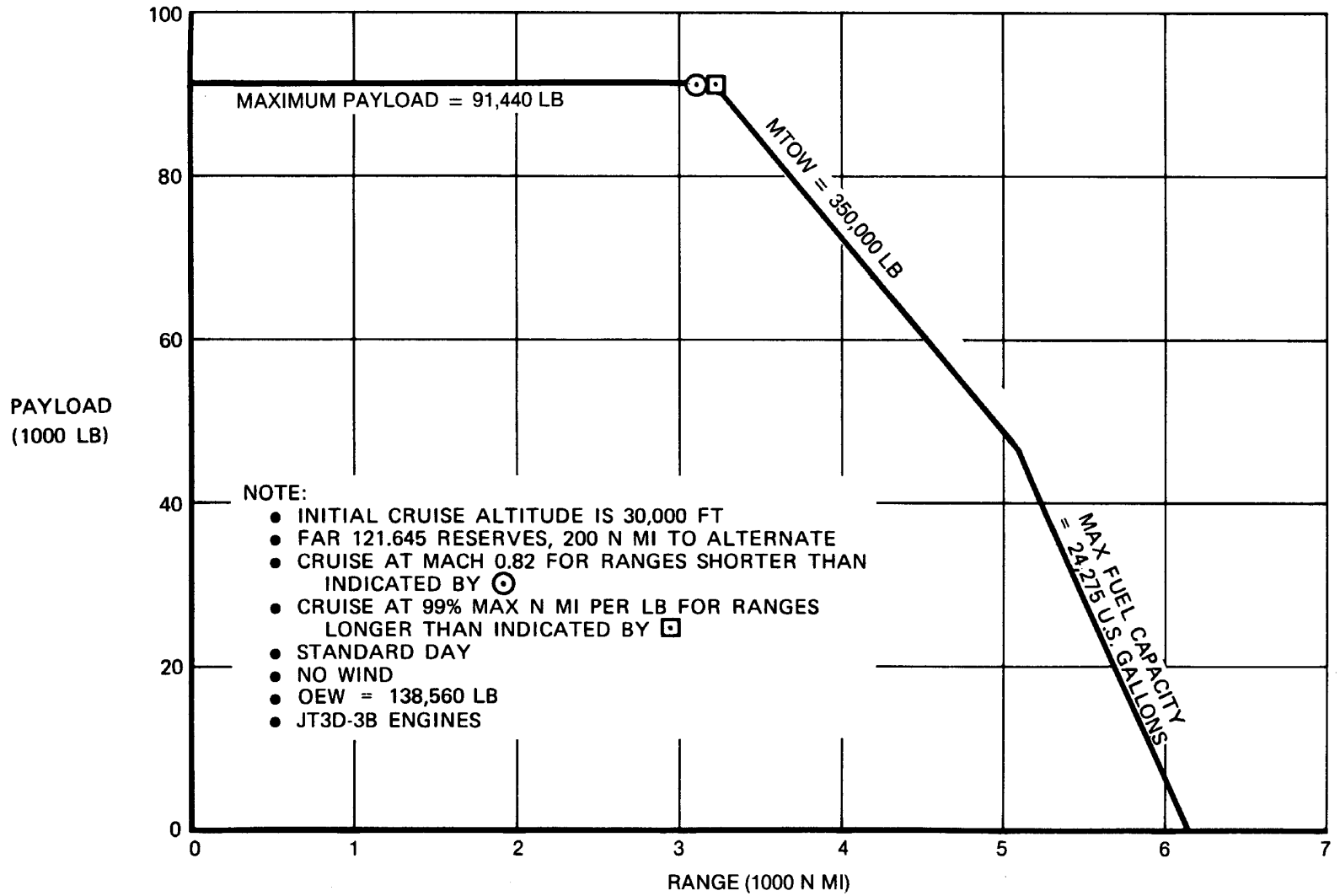

3.2 PAYLOAD/RANGE

3.2.1 PAYLOAD-RANGE CAPABILITIES FOR STEP ALTITUDE CRUISE (U.S. UNITS) MODEL DC-8-62F

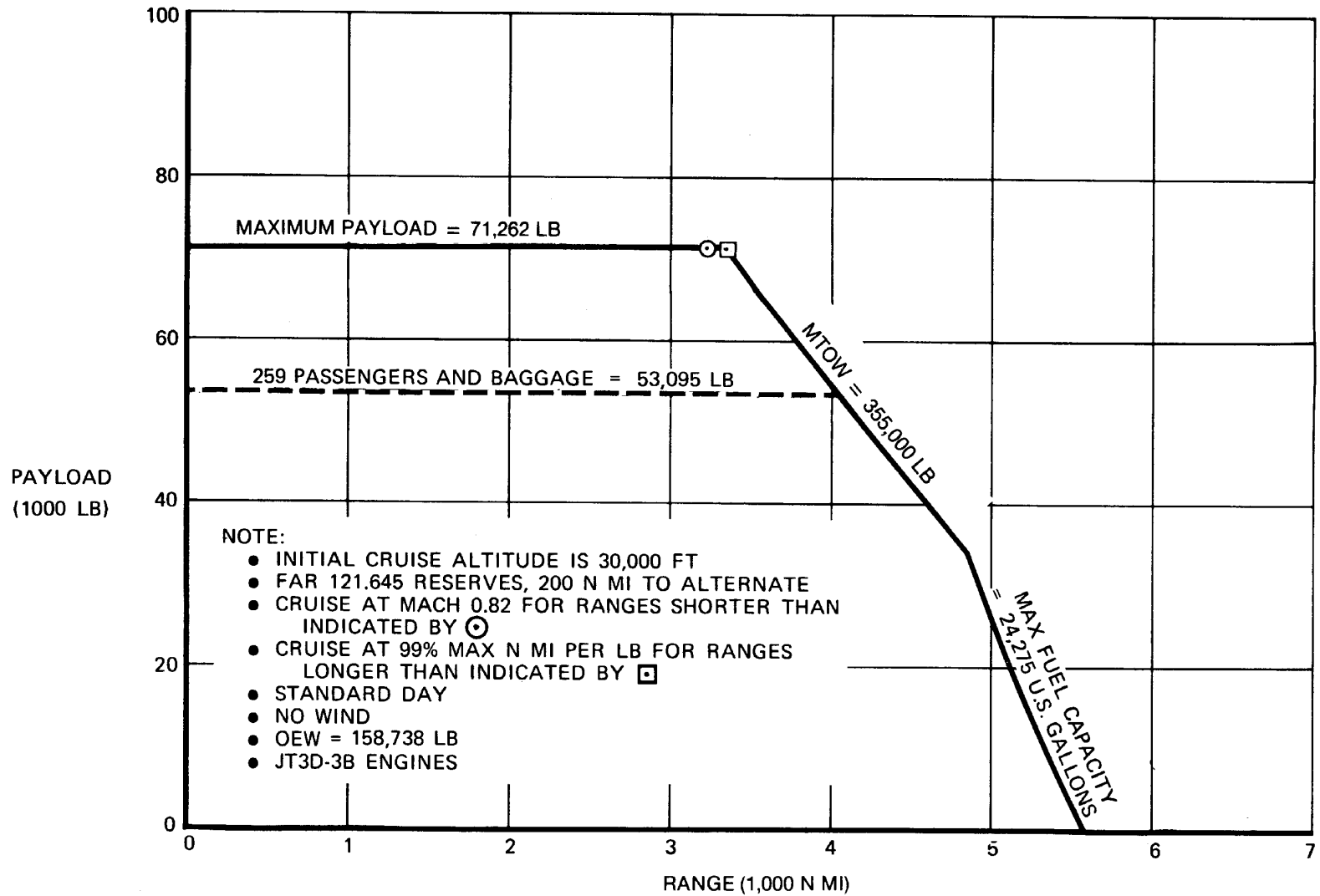

3.2 PAYLOAD/RANGE

3.2.1 PAYLOAD-RANGE CAPABILITIES FOR STEP ALTITUDE CRUISE (U.S. UNITS)

MODEL DC-8-63

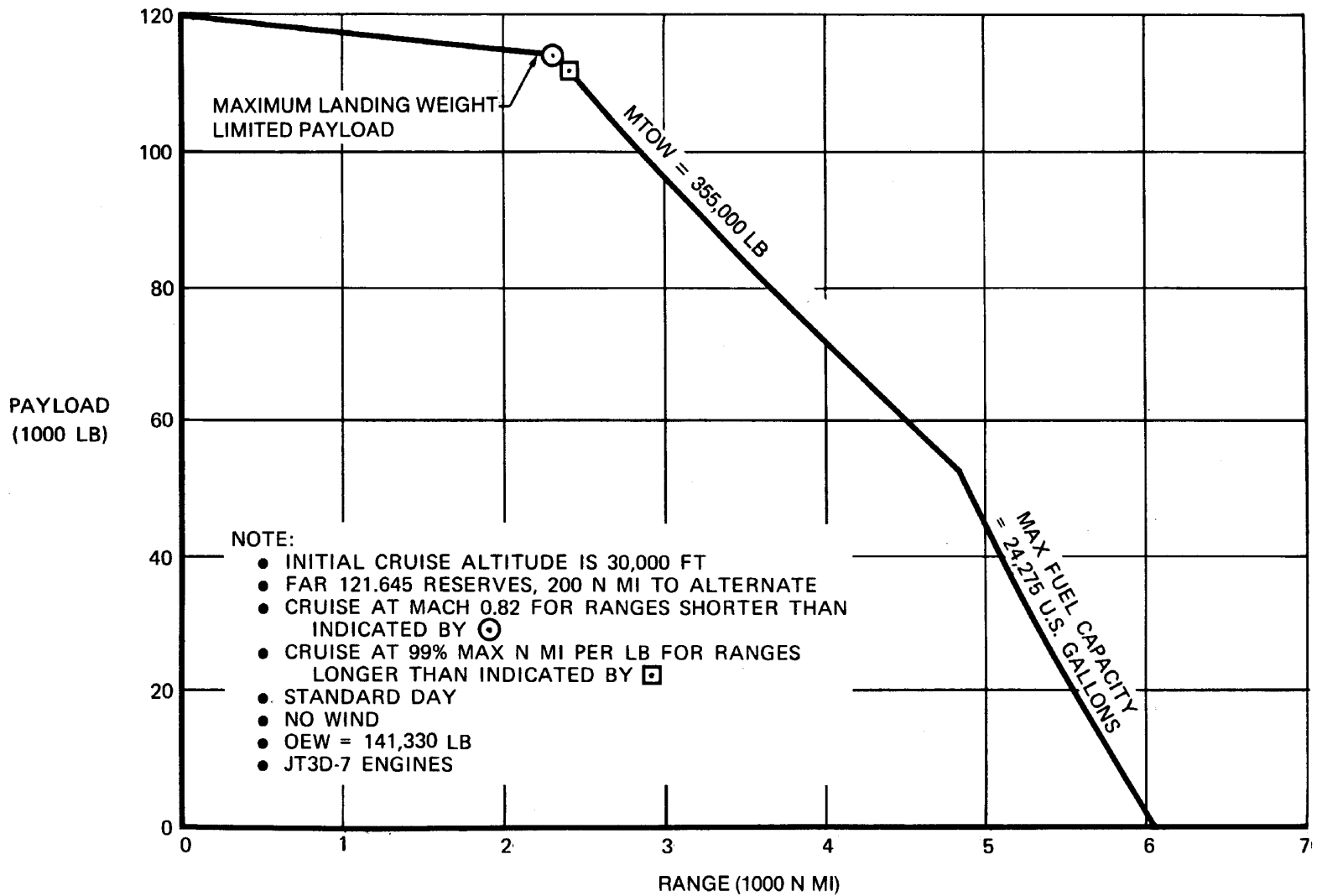

3.2 PAYLOAD/RANGE

3.2.1 PAYLOAD-RANGE CAPABILITIES FOR STEP ALTITUDE CRUISE (U.S. UNITS) MODEL DC-8-63F

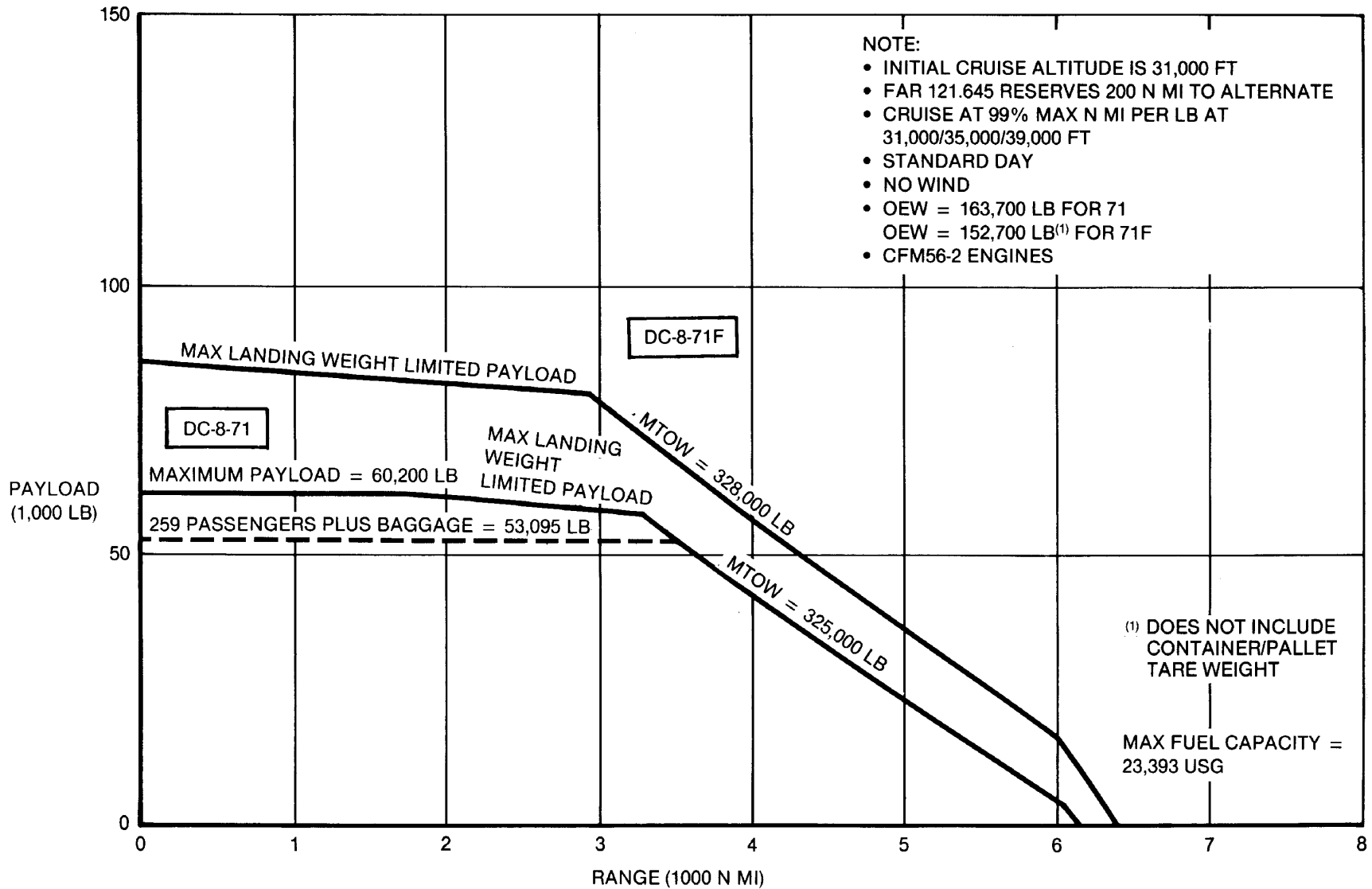

3.2 PAYLOAD/RANGE

3.2.1 PAYLOAD-RANGE CAPABILITIES FOR STEP ALTITUDE CRUISE (U.S. UNITS)

MODEL DC-8-71, 71F

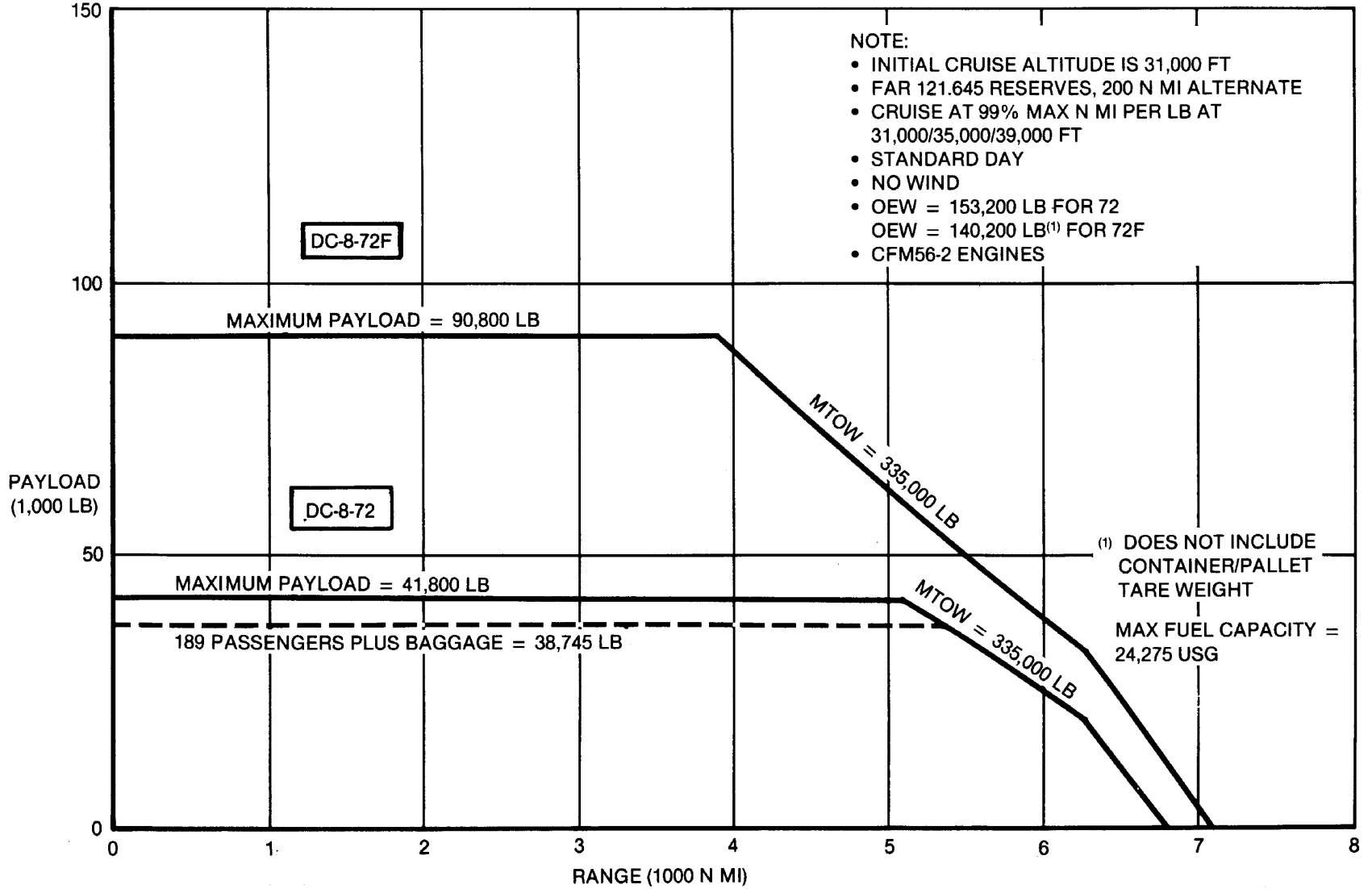

3.2 PAYLOAD/RANGE

3.2.1 PAYLOAD-RANGE CAPABILITIES FOR STEP ALTITUDE CRUISE (U.S. UNITS) MODEL DC-8-72, 72F

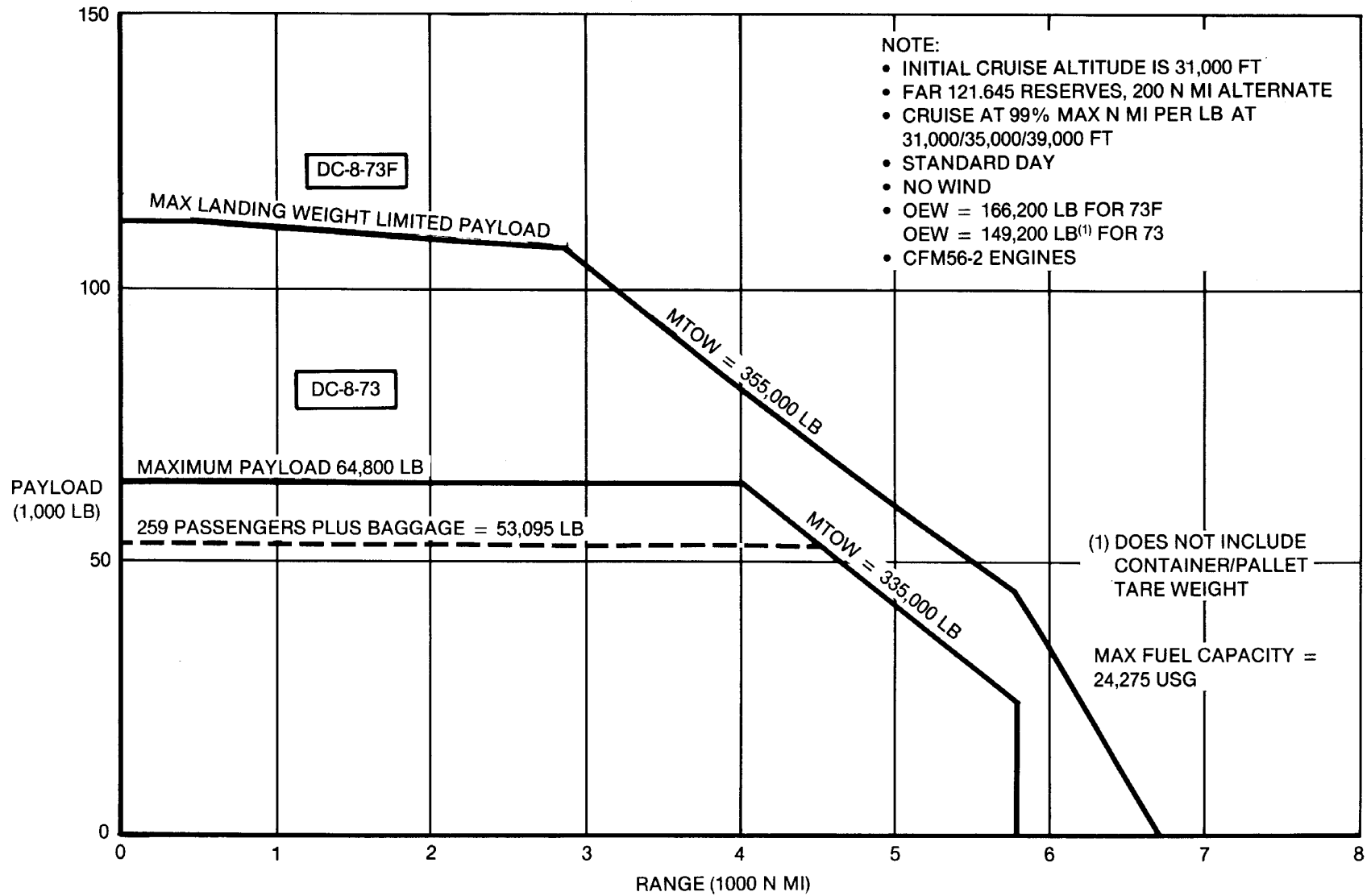

3.2 PAYLOAD/RANGE

3.2.1 PAYLOAD-RANGE CAPABILITIES FOR STEP ALTITUDE CRUISE (U.S. UNITS) MODEL DC-8-73, 73F

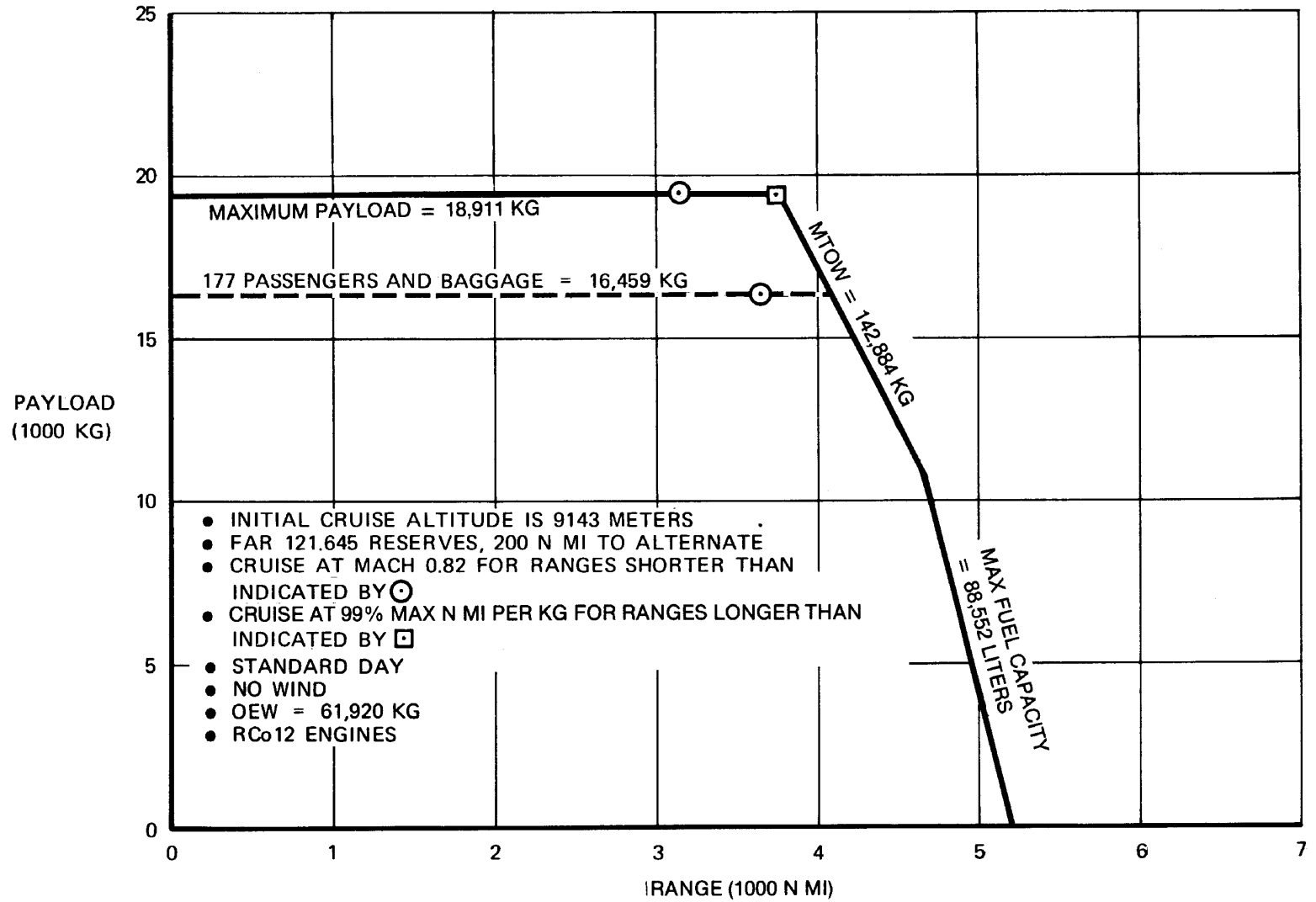

3.2 PAYLOAD/RANGE

3.2.2 PAYLOAD-RANGE CAPABILITIES FOR STEP ALTITUDE CRUISE (METRIC) MODEL DC-8-43

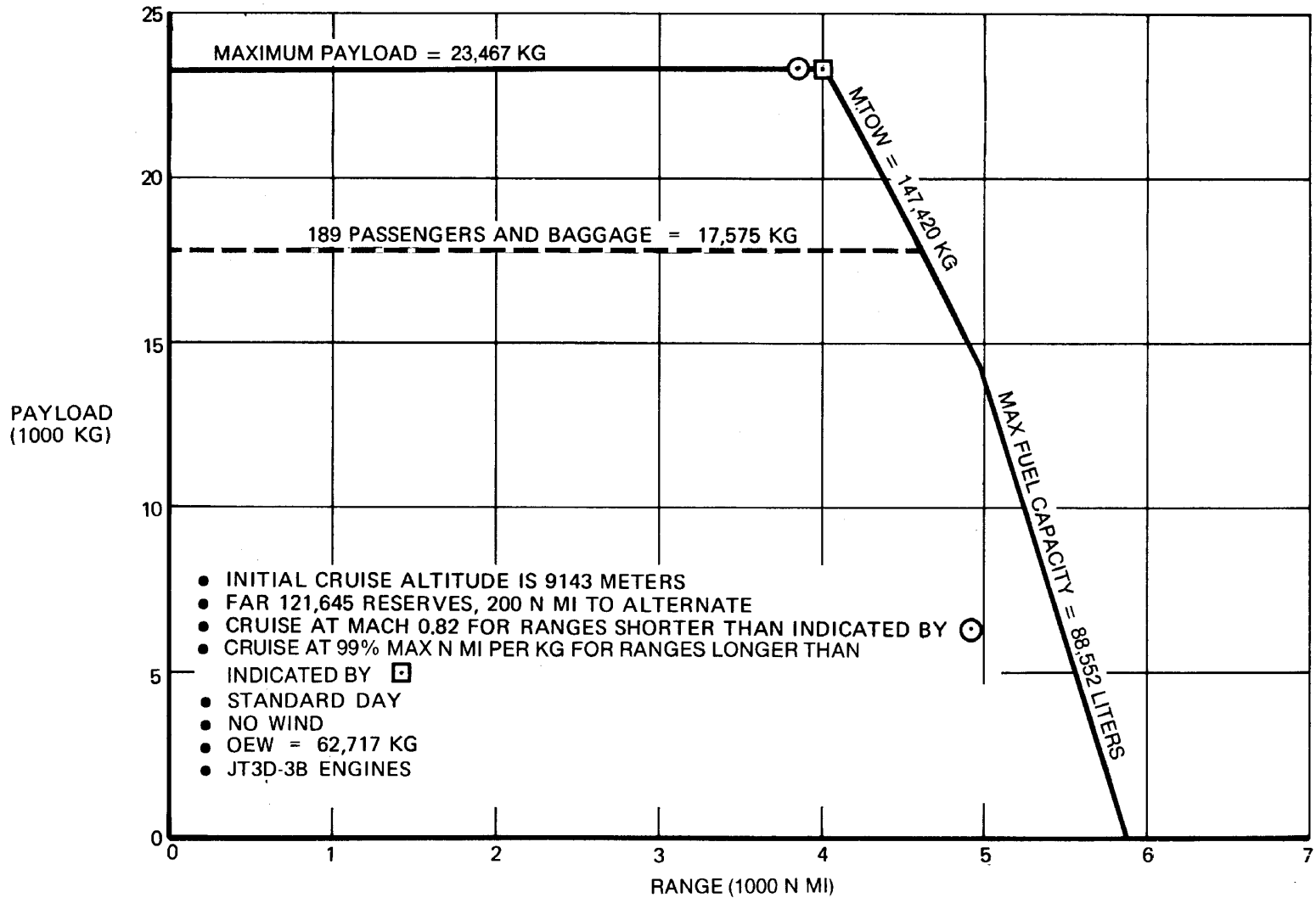

3.2 PAYLOAD/RANGE

3.2.2 PAYLOAD-RANGE CAPABILITIES FOR STEP ALTITUDE CRUISE (METRIC) MODEL DC-8-55

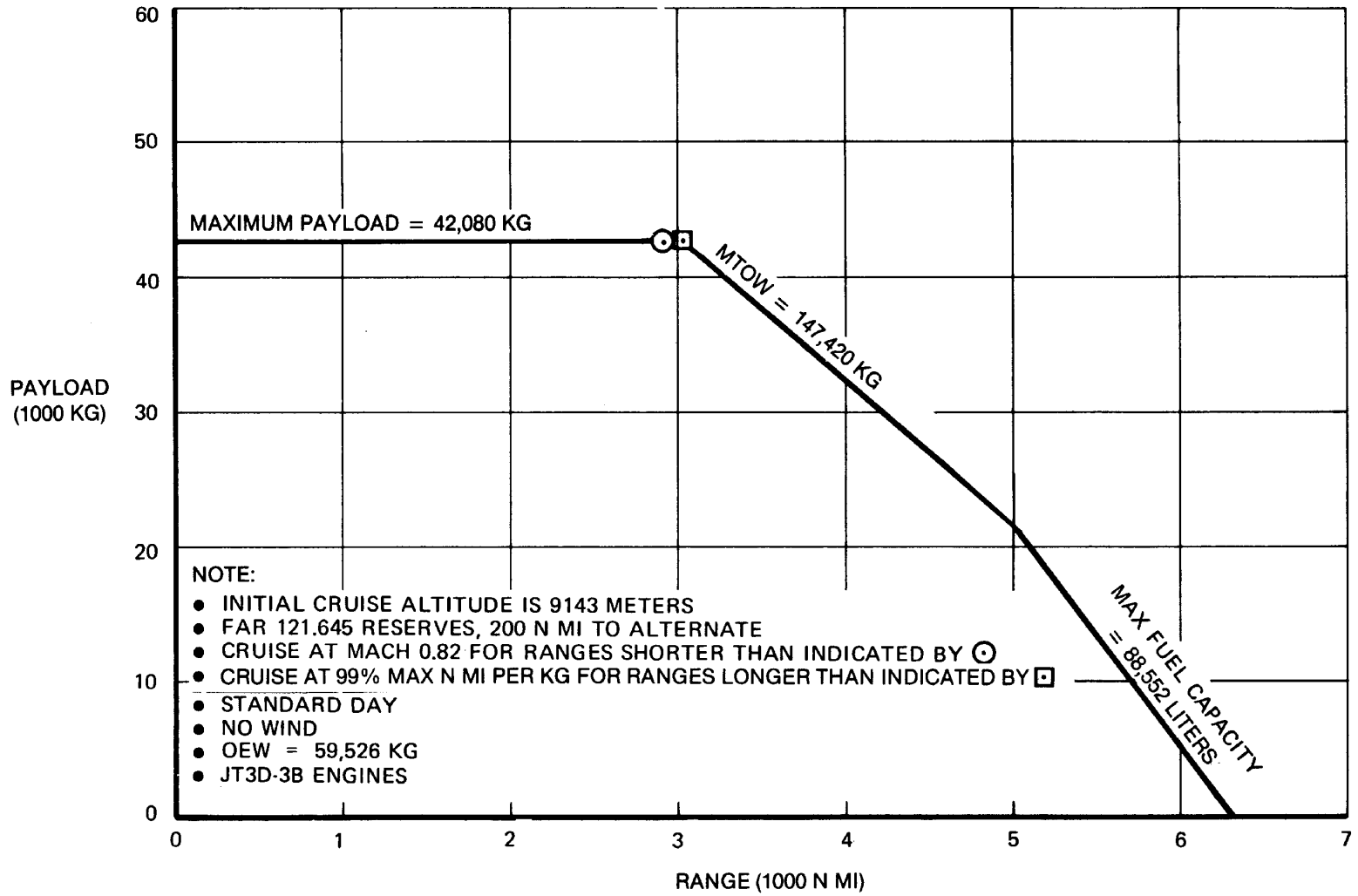

3.2 PAYLOAD/RANGE

3.2.2 PAYLOAD-RANGE CAPABILITIES FOR STEP ALTITUDE CRUISE (METRIC) MODEL DC-8-55F

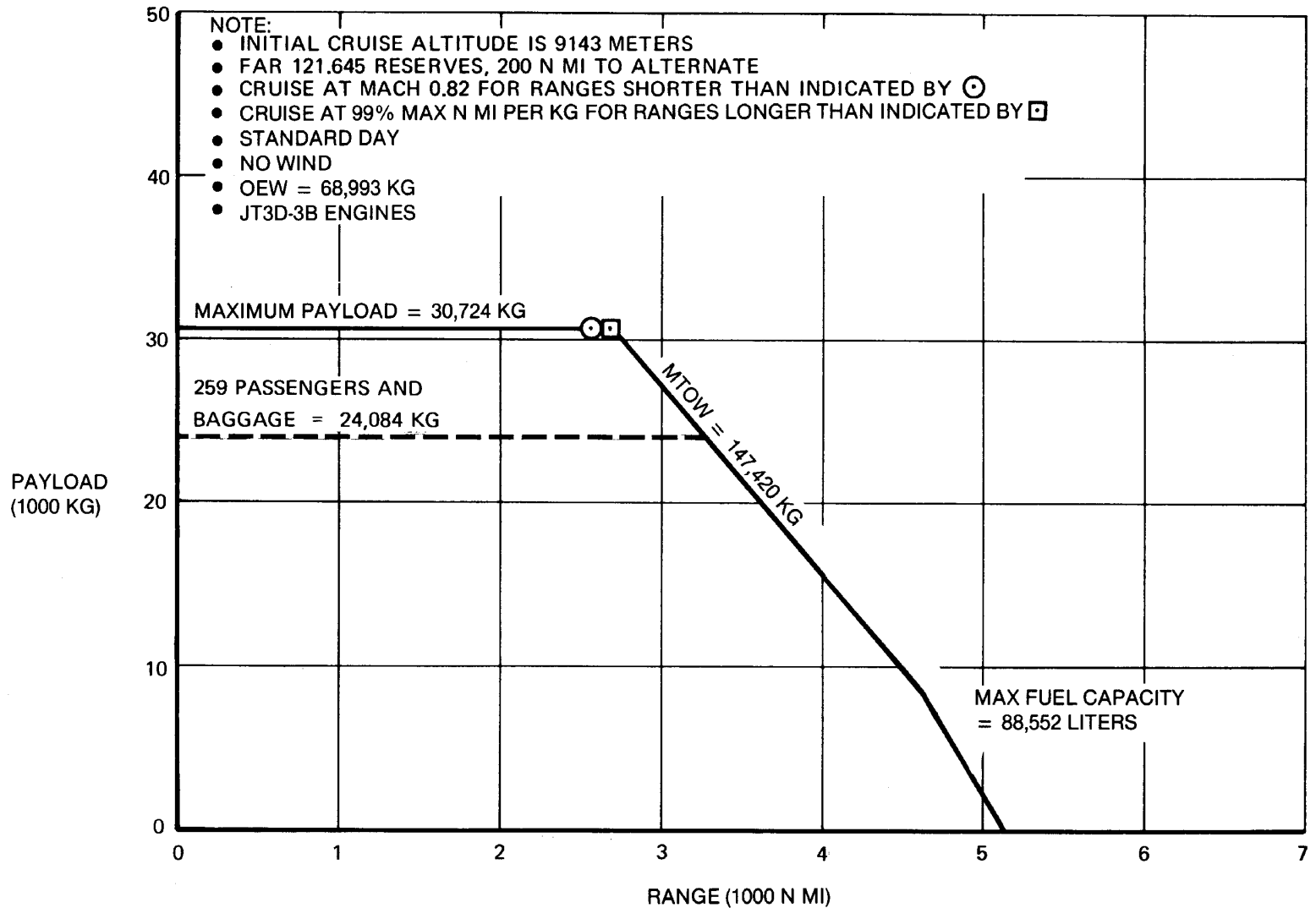

3.2 PAYLOAD/RANGE

3.2.2 PAYLOAD-RANGE CAPABILITIES FOR STEP ALTITUDE CRUISE (METRIC)

MODEL DC-8-61

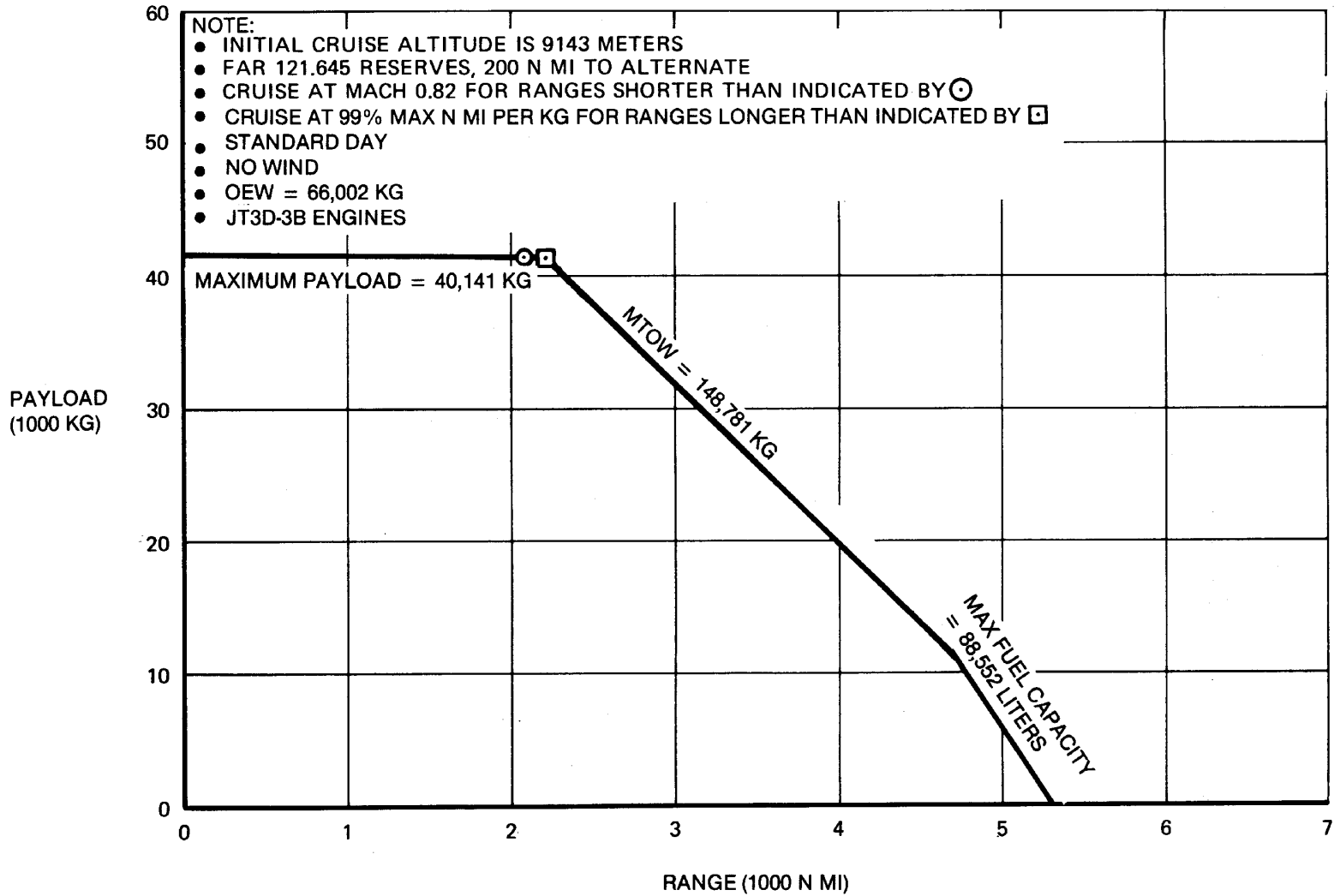

3.2 PAYLOAD/RANGE

3.2.2 PAYLOAD-RANGE CAPABILITIES FOR STEP ALTITUDE CRUISE (METRIC) MODEL DC-8-61F

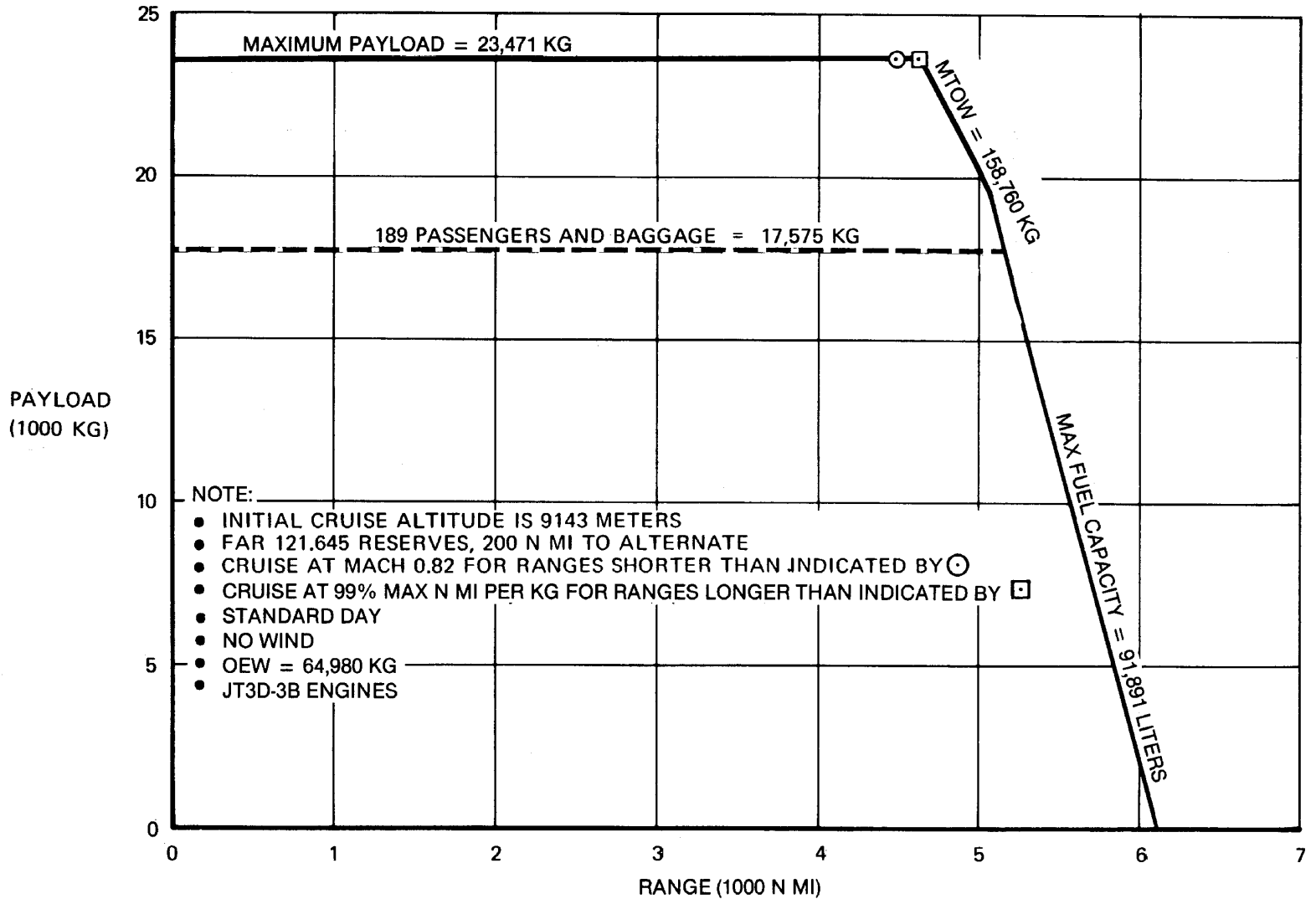

3.2 PAYLOAD/RANGE

3.2.2 PAYLOAD-RANGE CAPABILITIES FOR STEP ALTITUDE CRUISE (METRIC) MODEL DC-8-62

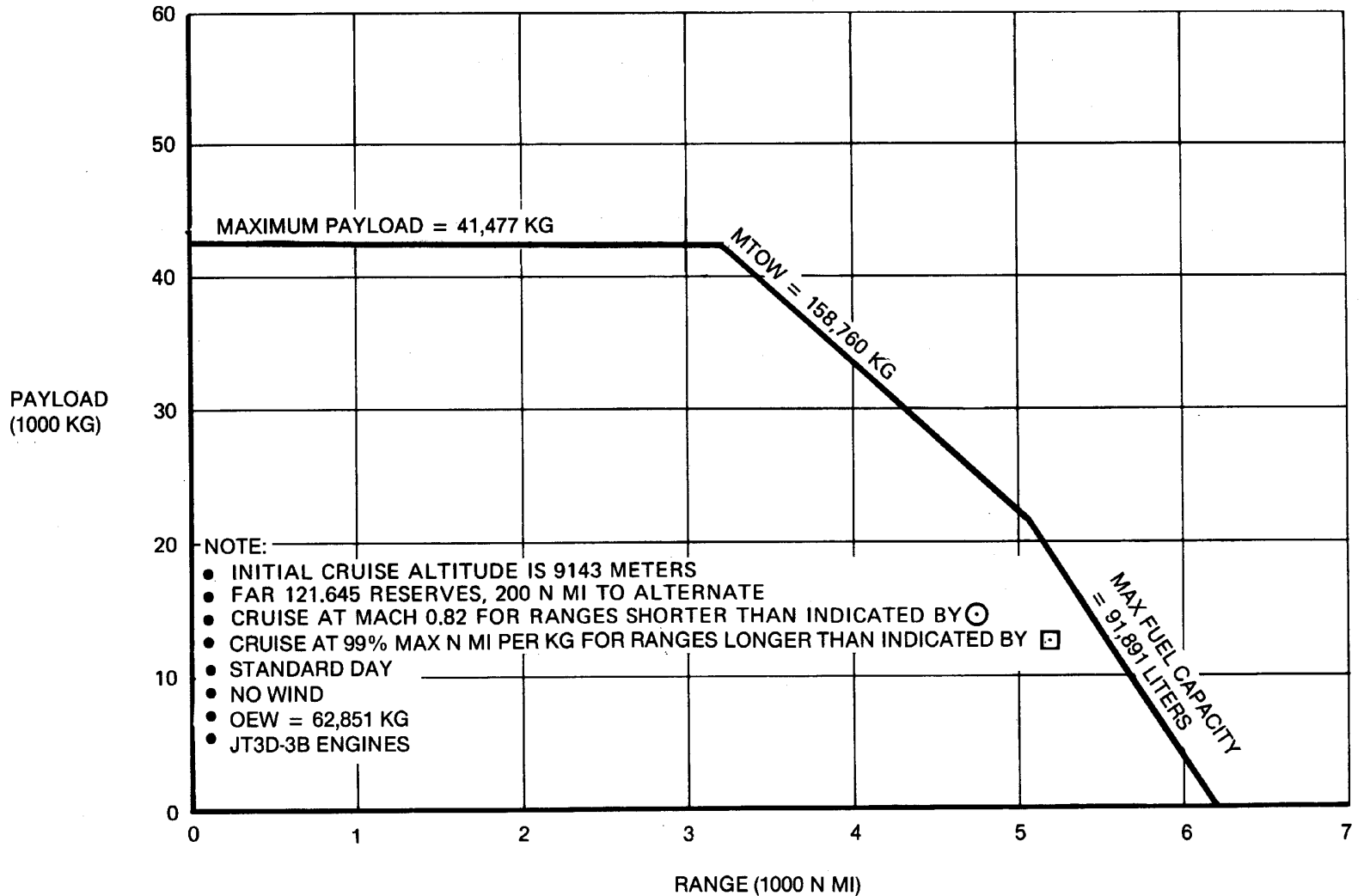

3.2 PAYLOAD/RANGE

3.2.2 PAYLOAD-RANGE CAPABILITIES FOR STEP ALTITUDE CRUISE (METRIC) MODEL DC-8-62F

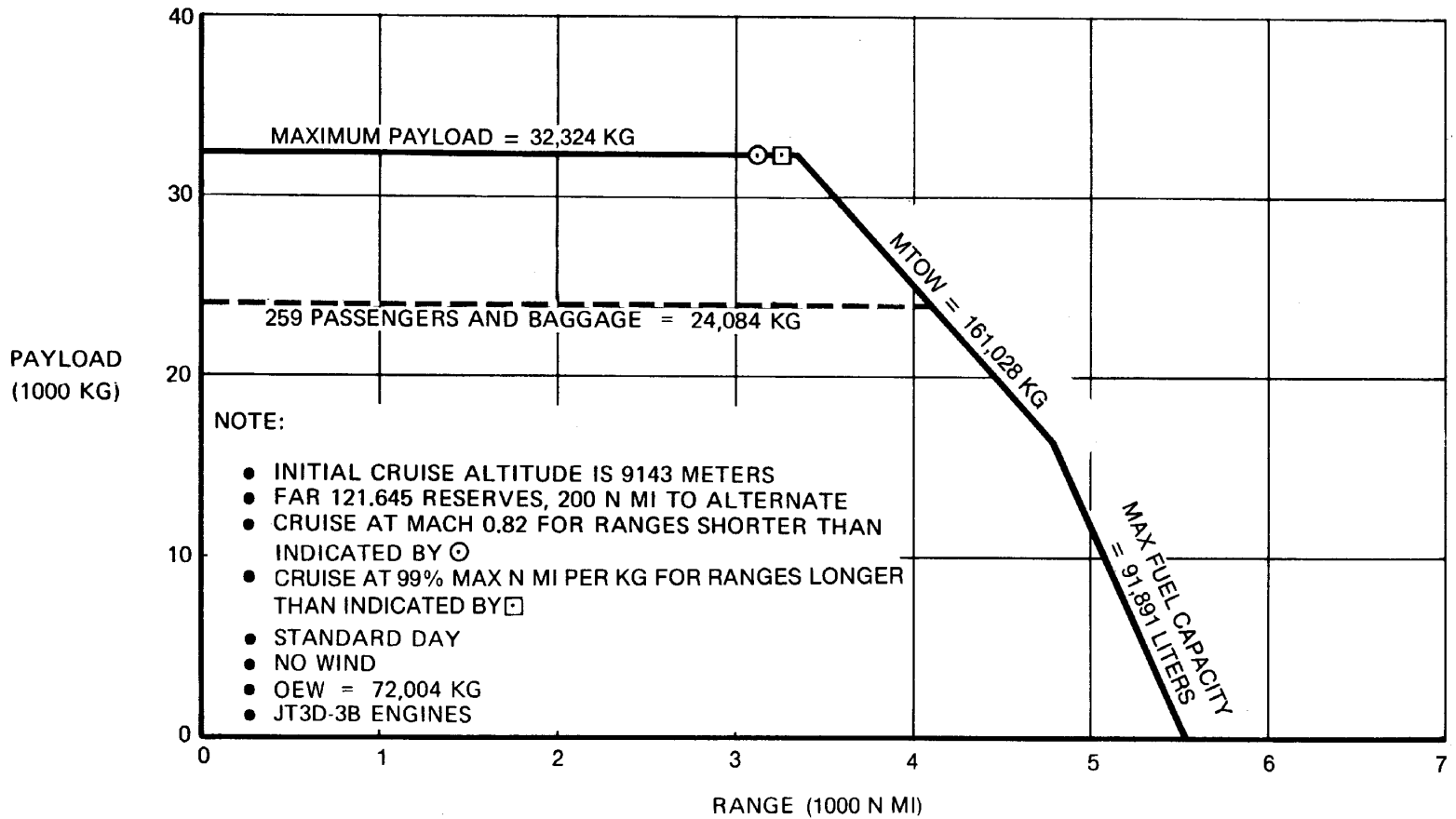

3.2 PAYLOAD/RANGE

3.2.2 PAYLOAD-RANGE CAPABILITIES FOR STEP ALTITUDE CRUISE (METRIC) MODEL DC-8-63

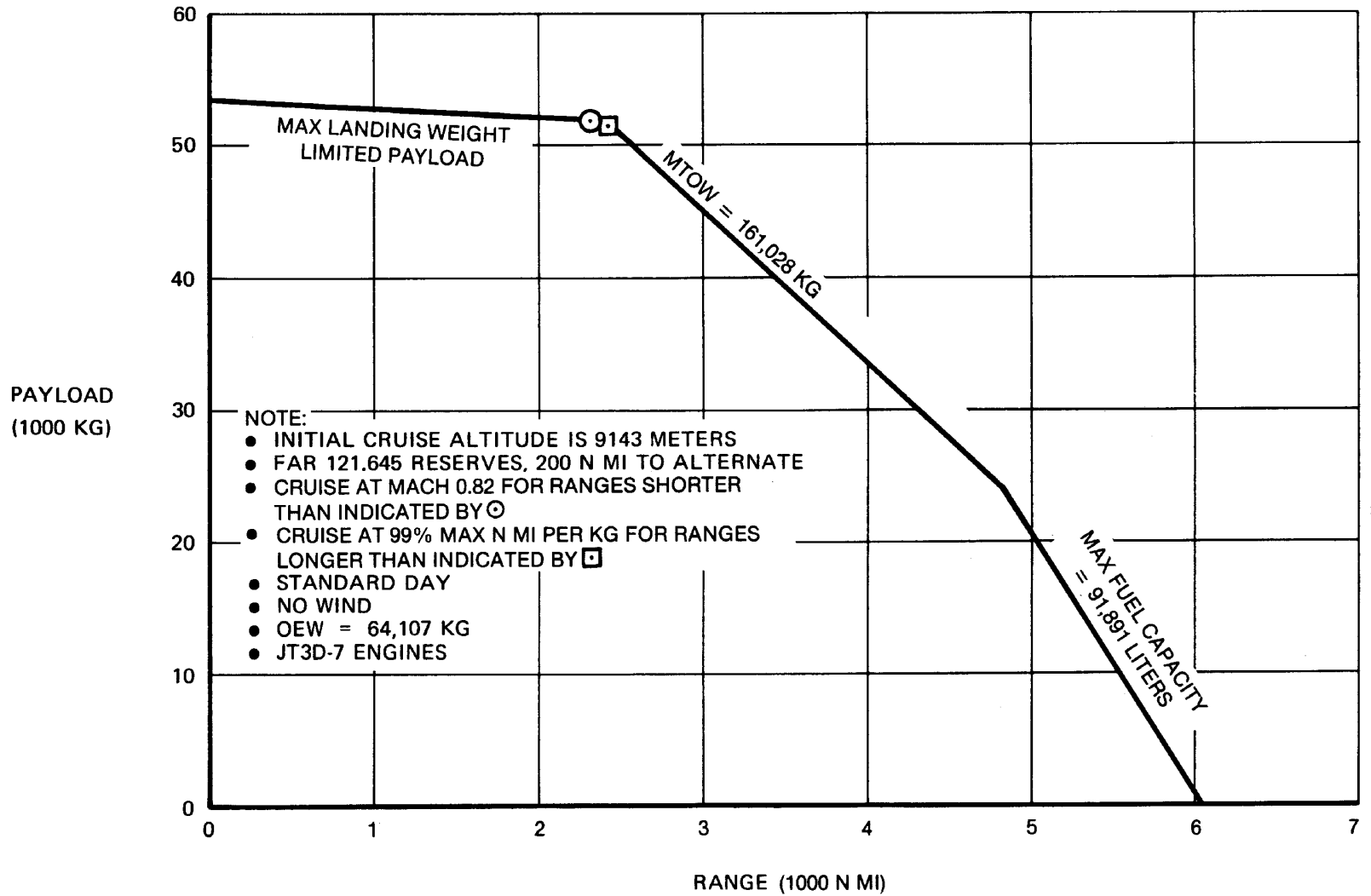

3.2 PAYLOAD/RANGE

3.2.2 PAYLOAD-RANGE CAPABILITIES FOR STEP ALTITUDE CRUISE (METRIC) MODEL DC-8-63F

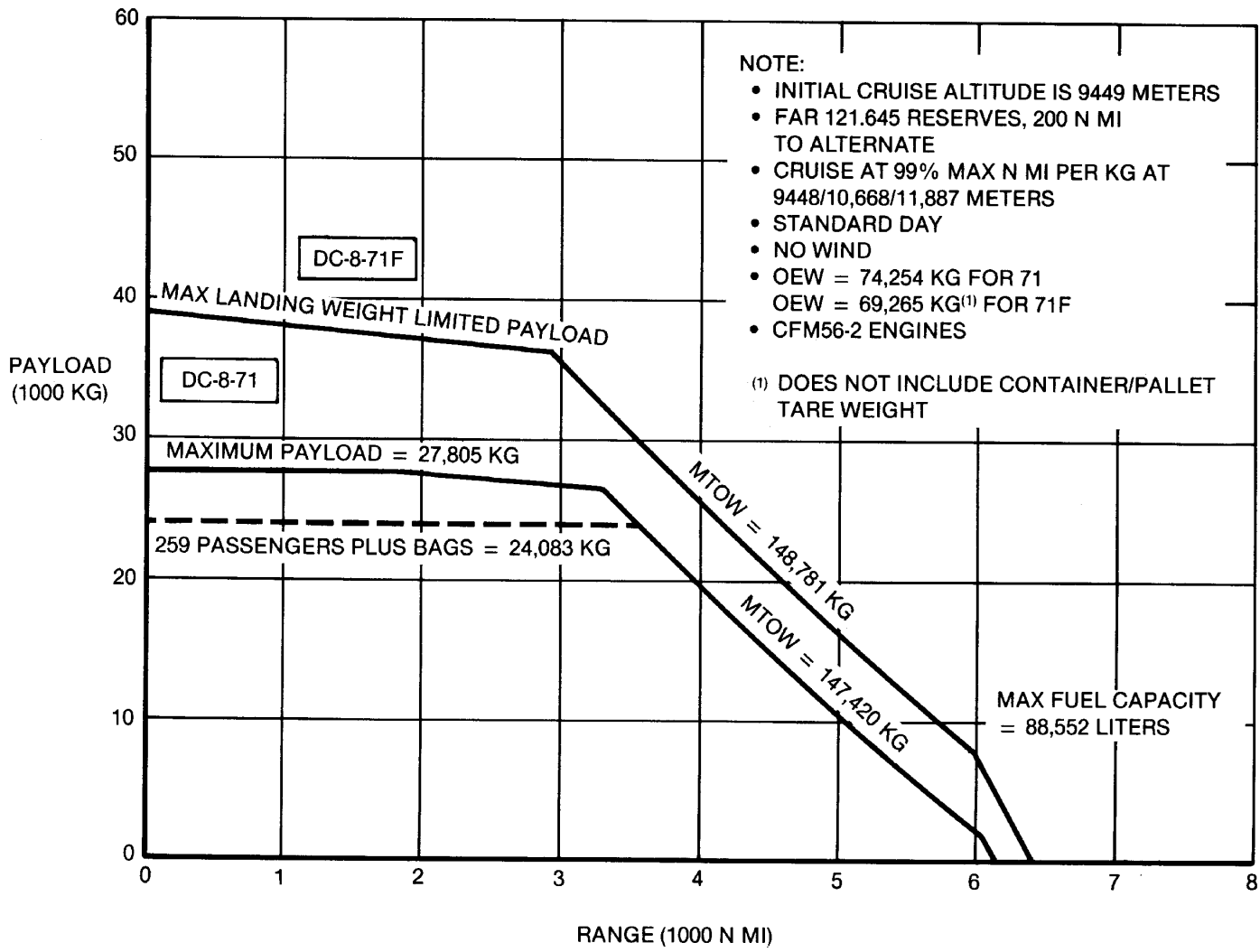

3.2 PAYLOAD/RANGE

3.2.2 PAYLOAD-RANGE CAPABILITIES FOR STEP ALTITUDE CRUISE (METRIC) MODEL DC-8-71, -71F

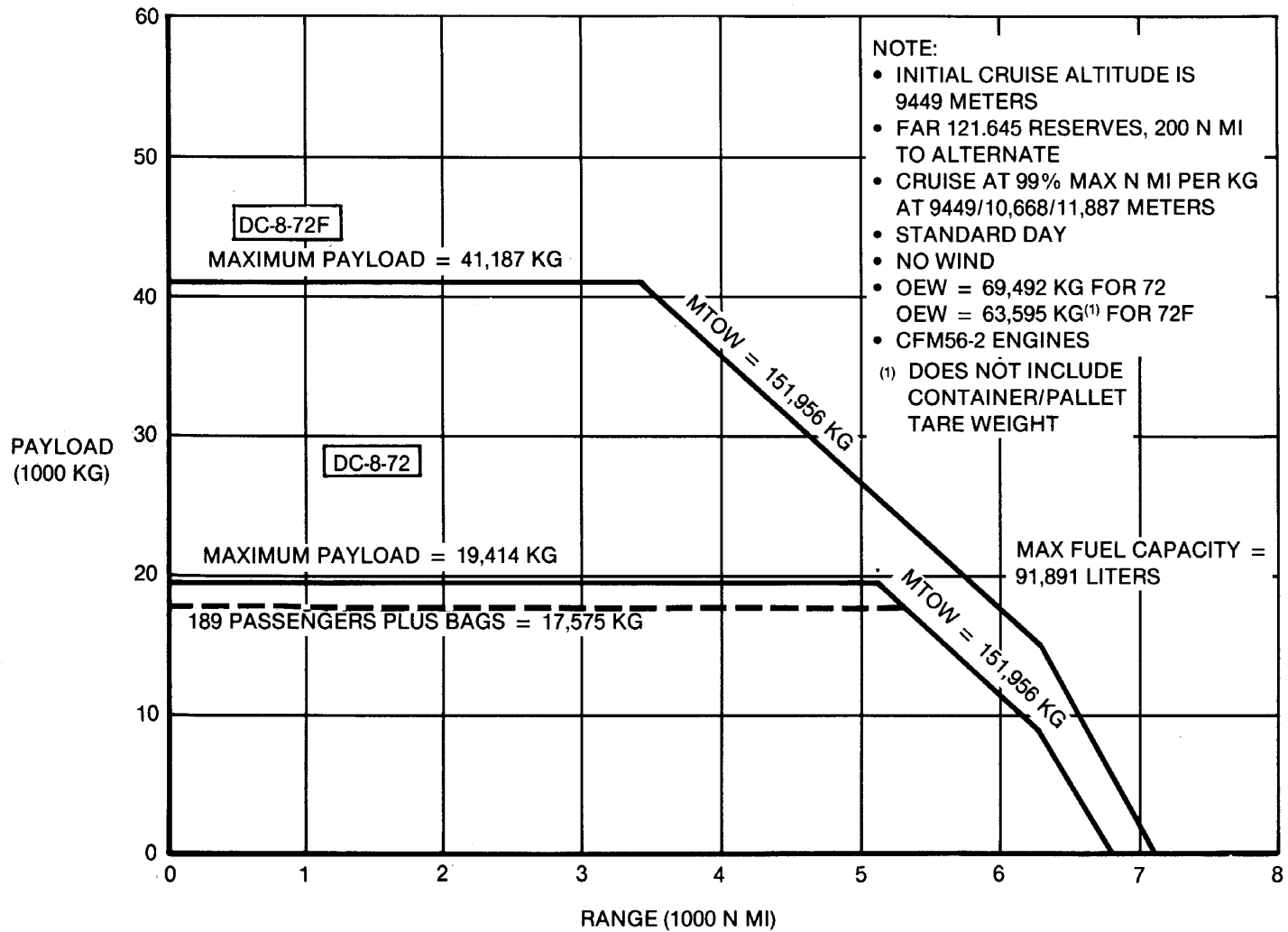

3.2 PAYLOAD/RANGE

3.2.2 PAYLOAD-RANGE CAPABILITIES FOR STEP ALTITUDE CRUISE (METRIC) MODEL DC-8-72, -72F

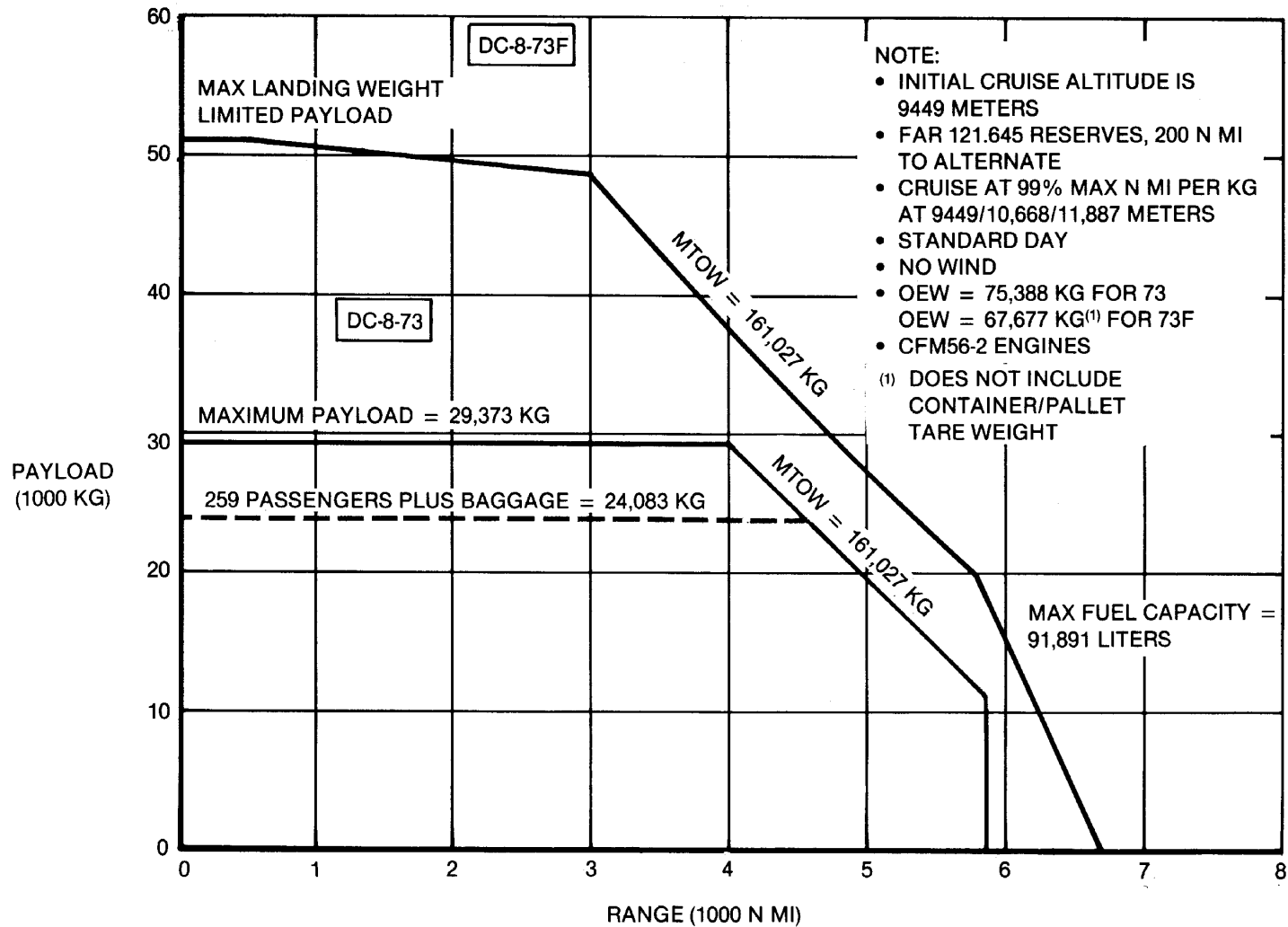

3.2 PAYLOAD/RANGE

3.2.2 PAYLOAD-RANGE CAPABILITIES FOR STEP ALTITUDE CRUISE (METRIC) MODEL DC-8-73, -73F

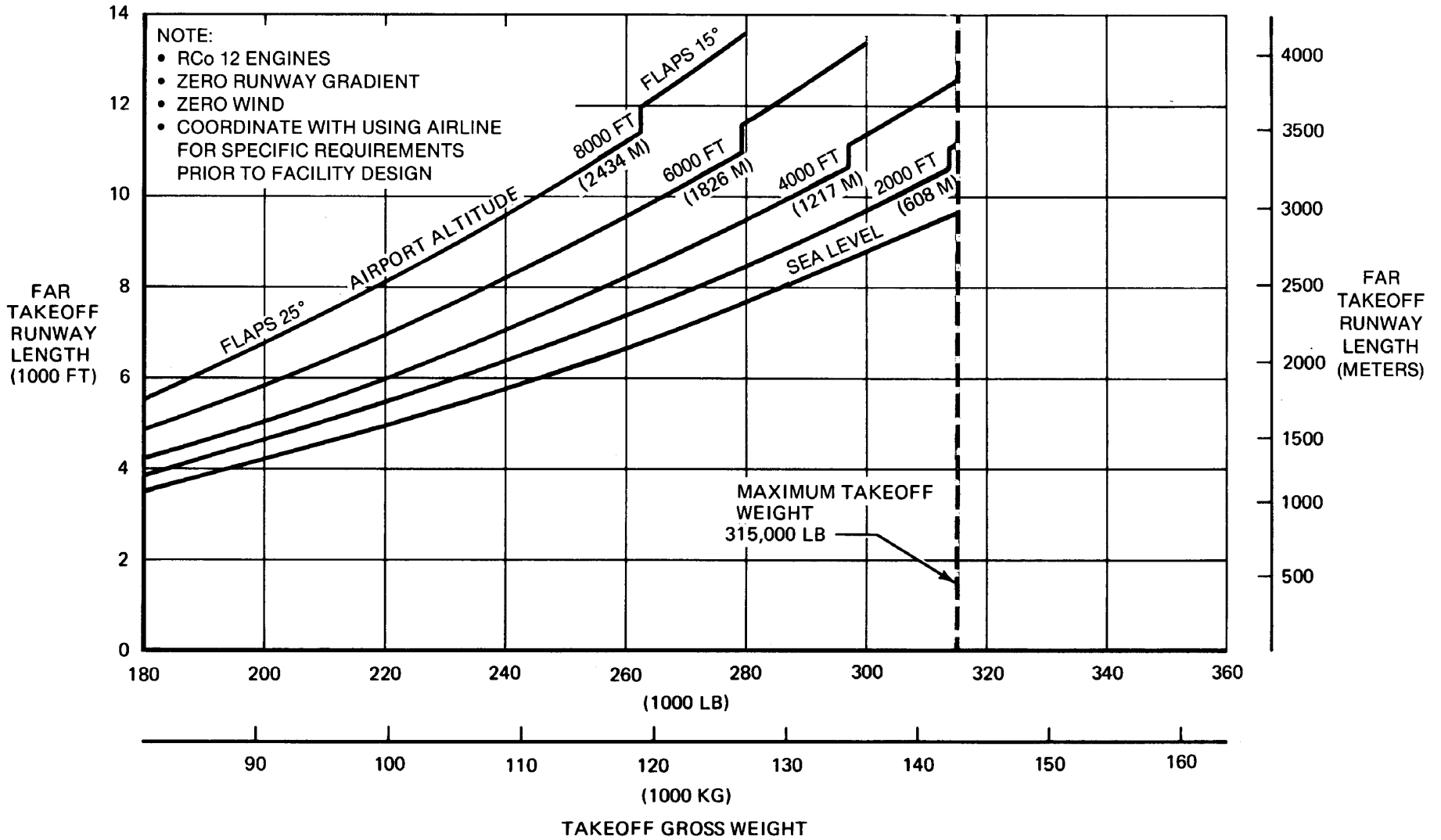

3.3 FAR TAKEOFF RUNWAY LENGTH REQUIREMENTS

3.3.1 STANDARD DAY

MODEL DC-8-43

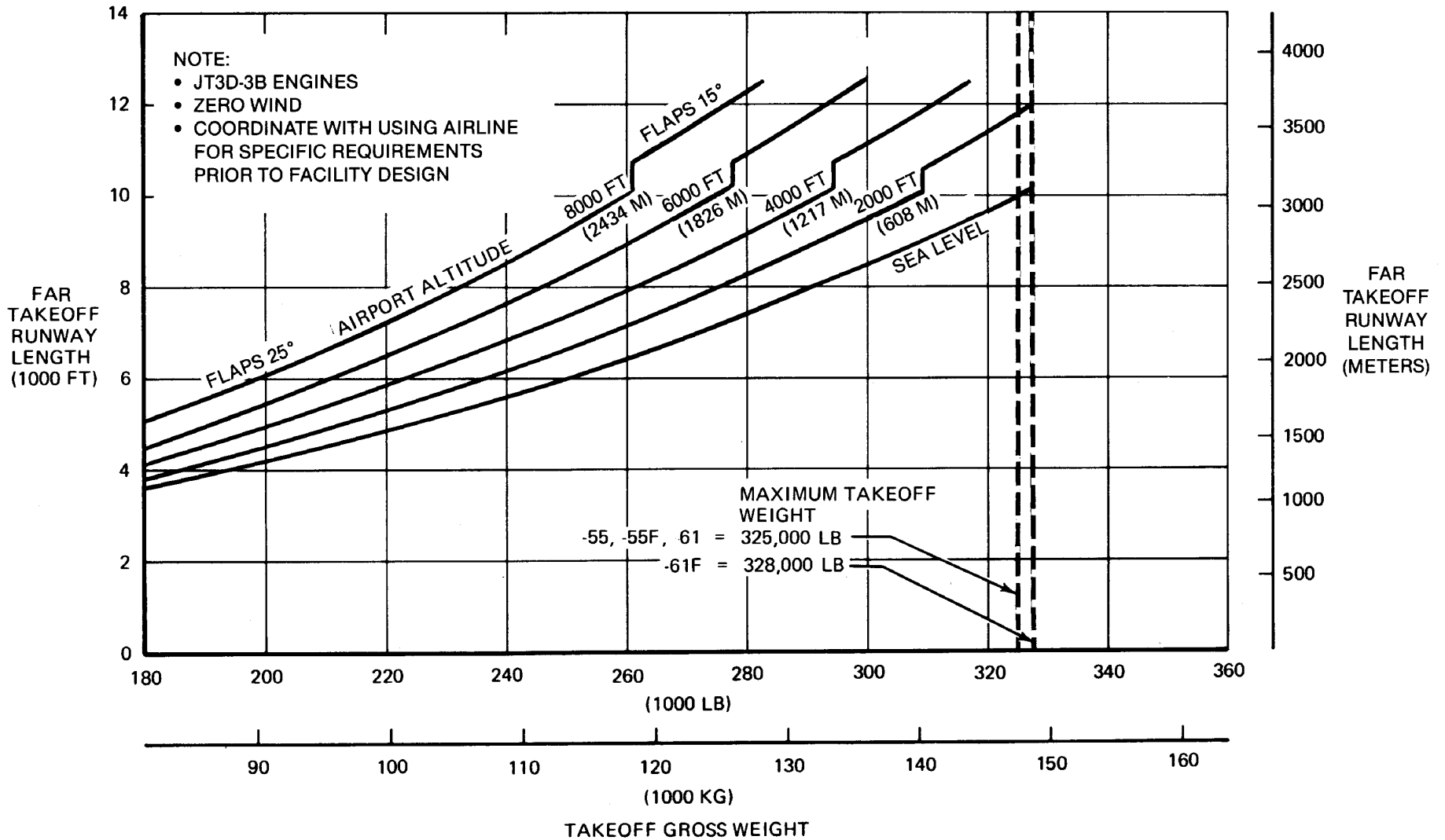

3.3 FAR TAKEOFF RUNWAY LENGTH REQUIREMENTS

3.3.1 STANDARD DAY

MODEL DC-8-55, -55F, -61, -61F

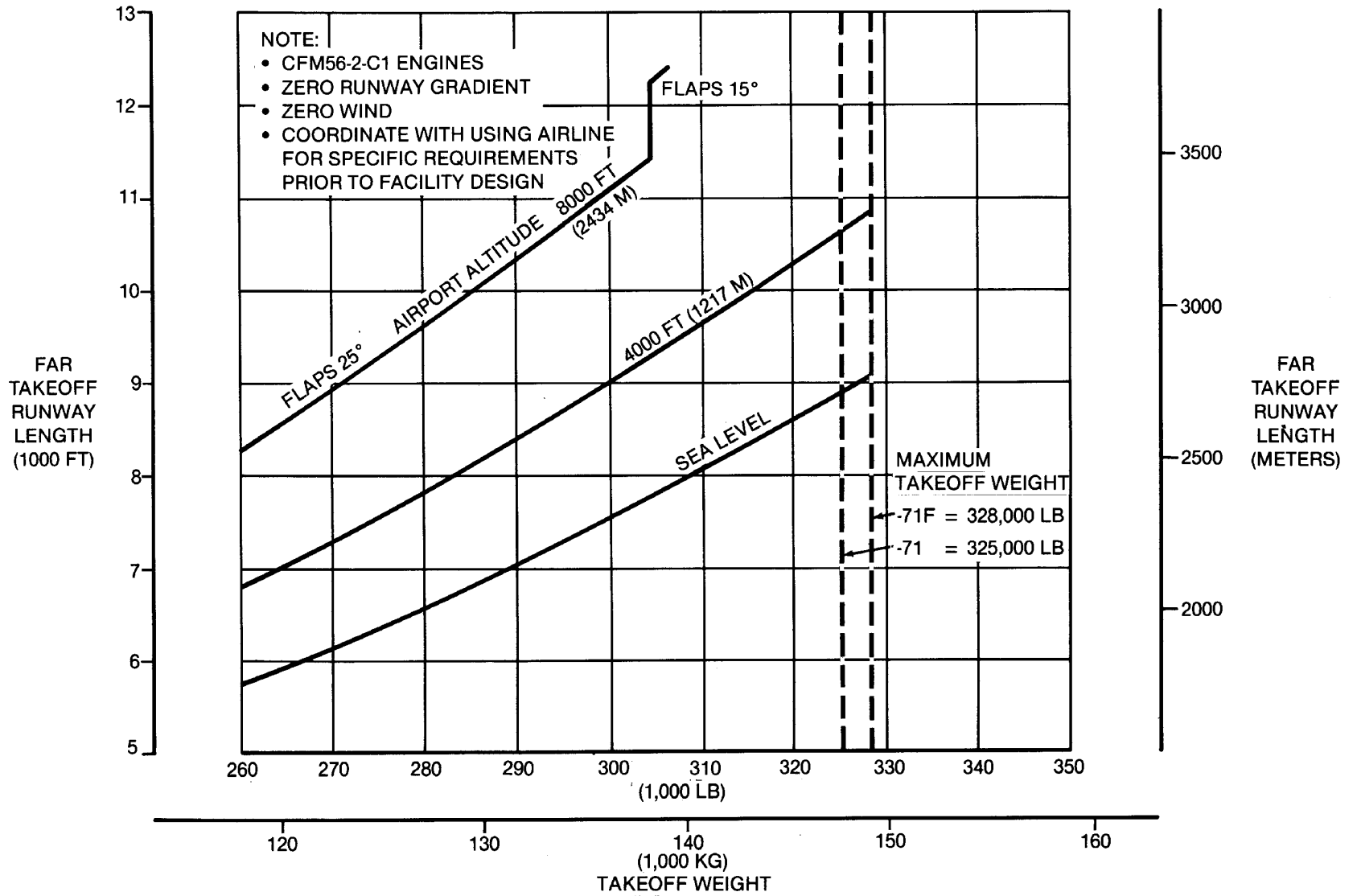

3.3 FAR TAKEOFF RUNWAY LENGTH REQUIREMENTS

3.3.1 STANDARD DAY

MODEL DC-8-71, -71F

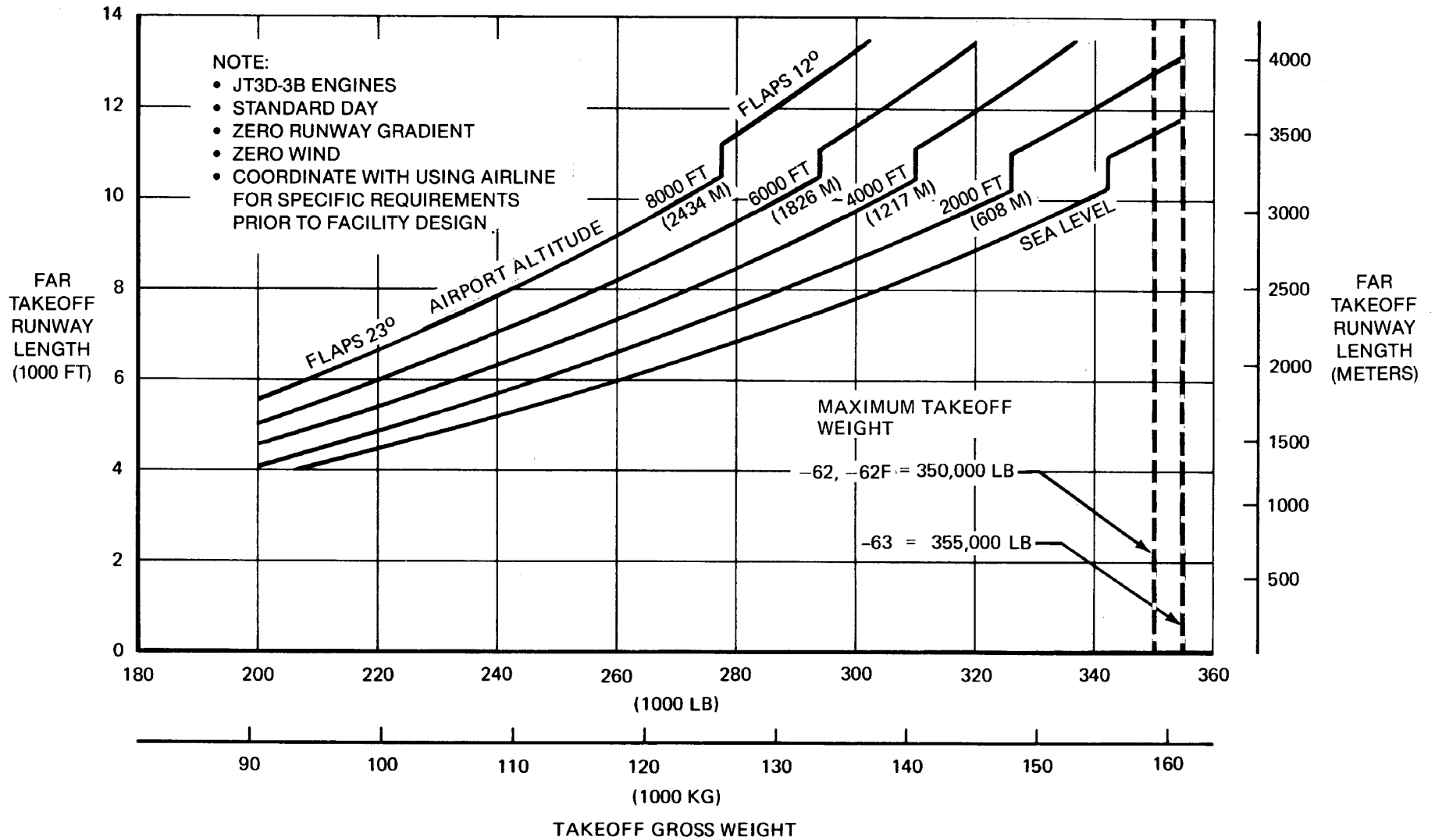

3.3 FAR TAKEOFF RUNWAY LENGTH REQUIREMENTS
3.3.1 STANDARD DAY
MODEL DC-8-62, -62F, -63

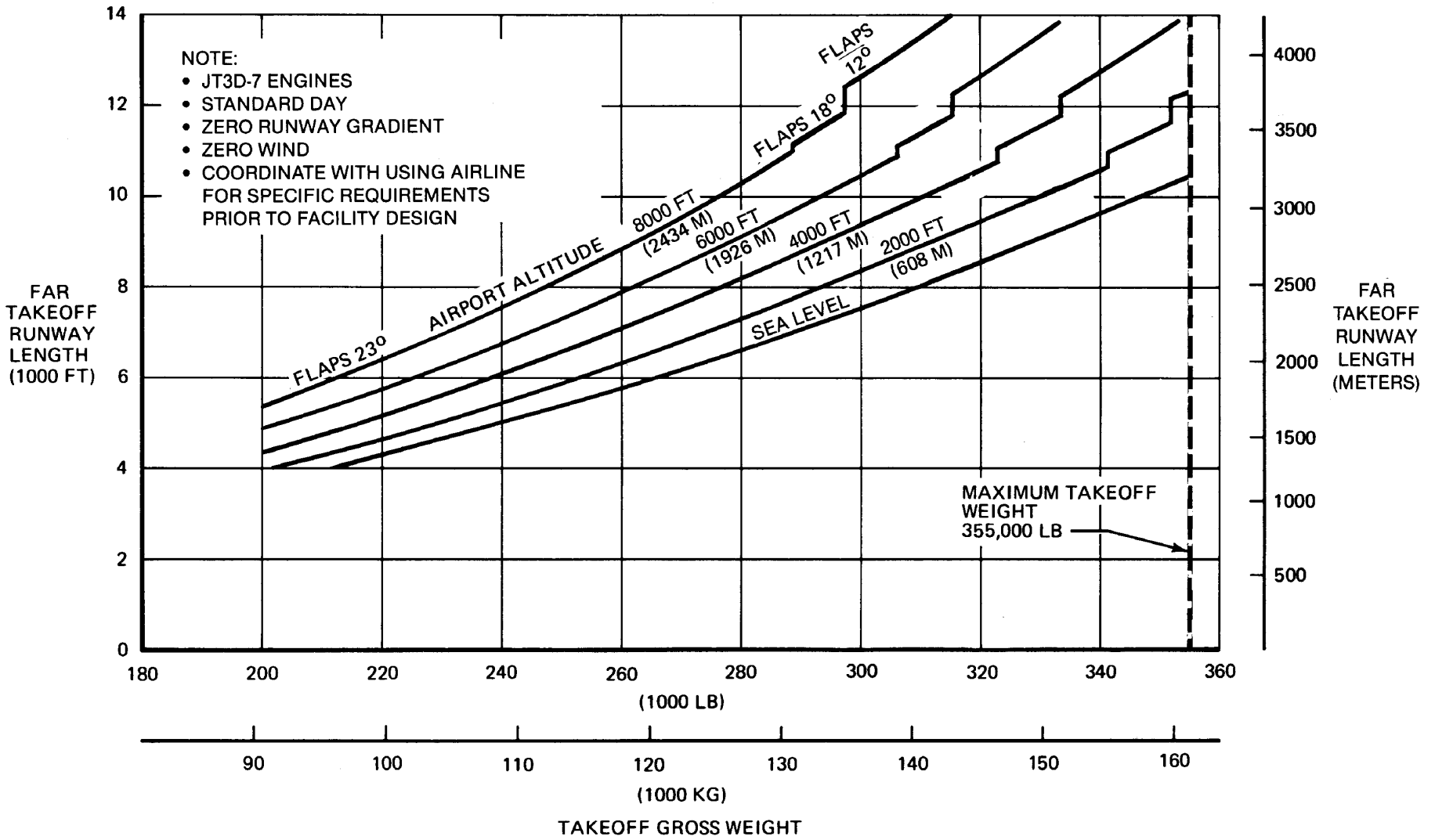

Not Subject to FAR or ITAR. Copyright © 2023 Boeing. All Rights Reserved.

74

REV A

3.3 FAR TAKEOFF RUNWAY LENGTH REQUIREMENTS

3.3.1 STANDARD DAY

MODEL DC-8-63F

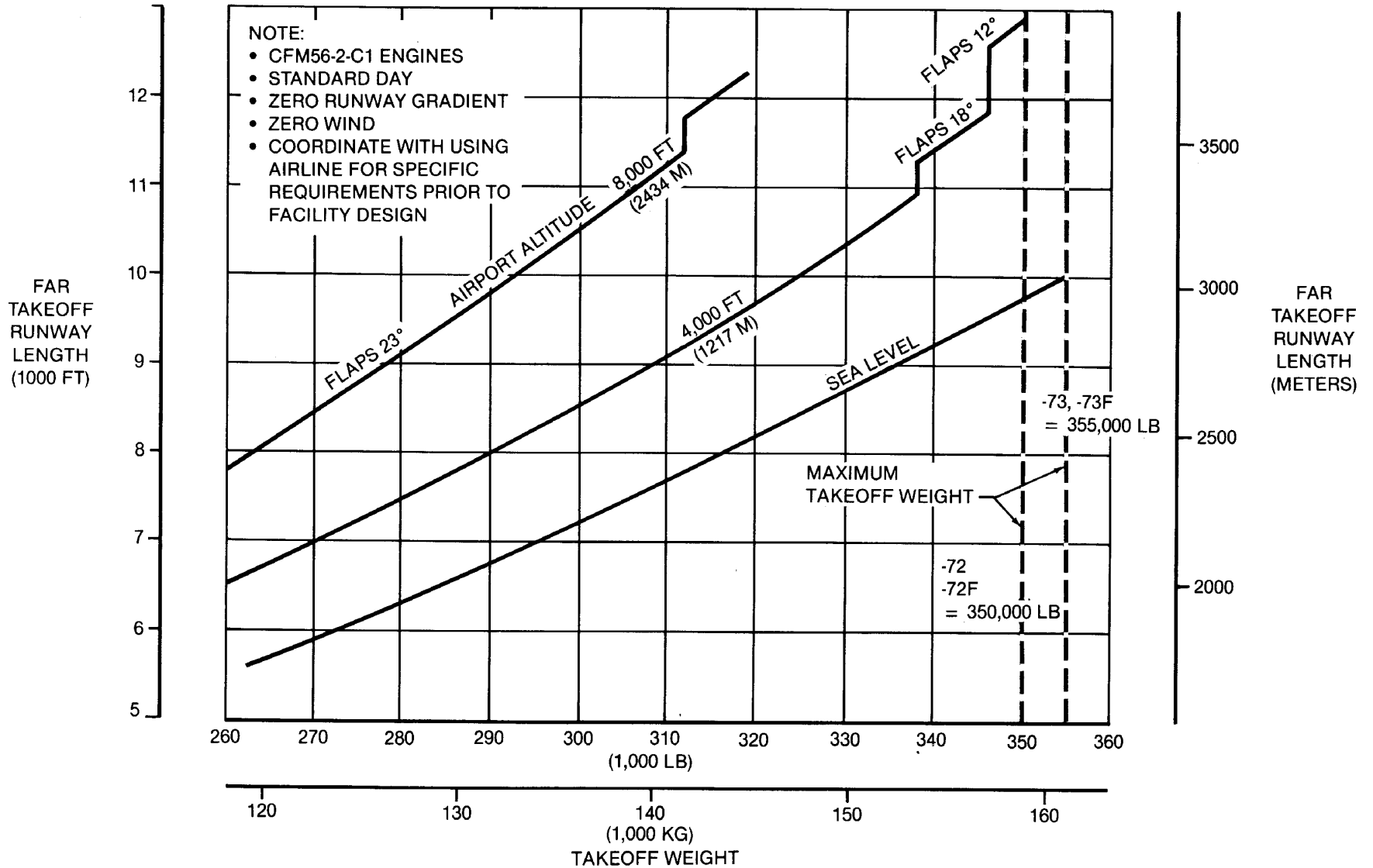

3.3 FAR TAKEOFF RUNWAY LENGTH REQUIREMENTS
3.3.1 STANDARD DAY
MODEL DC-8-72, -72F, -73, -73F

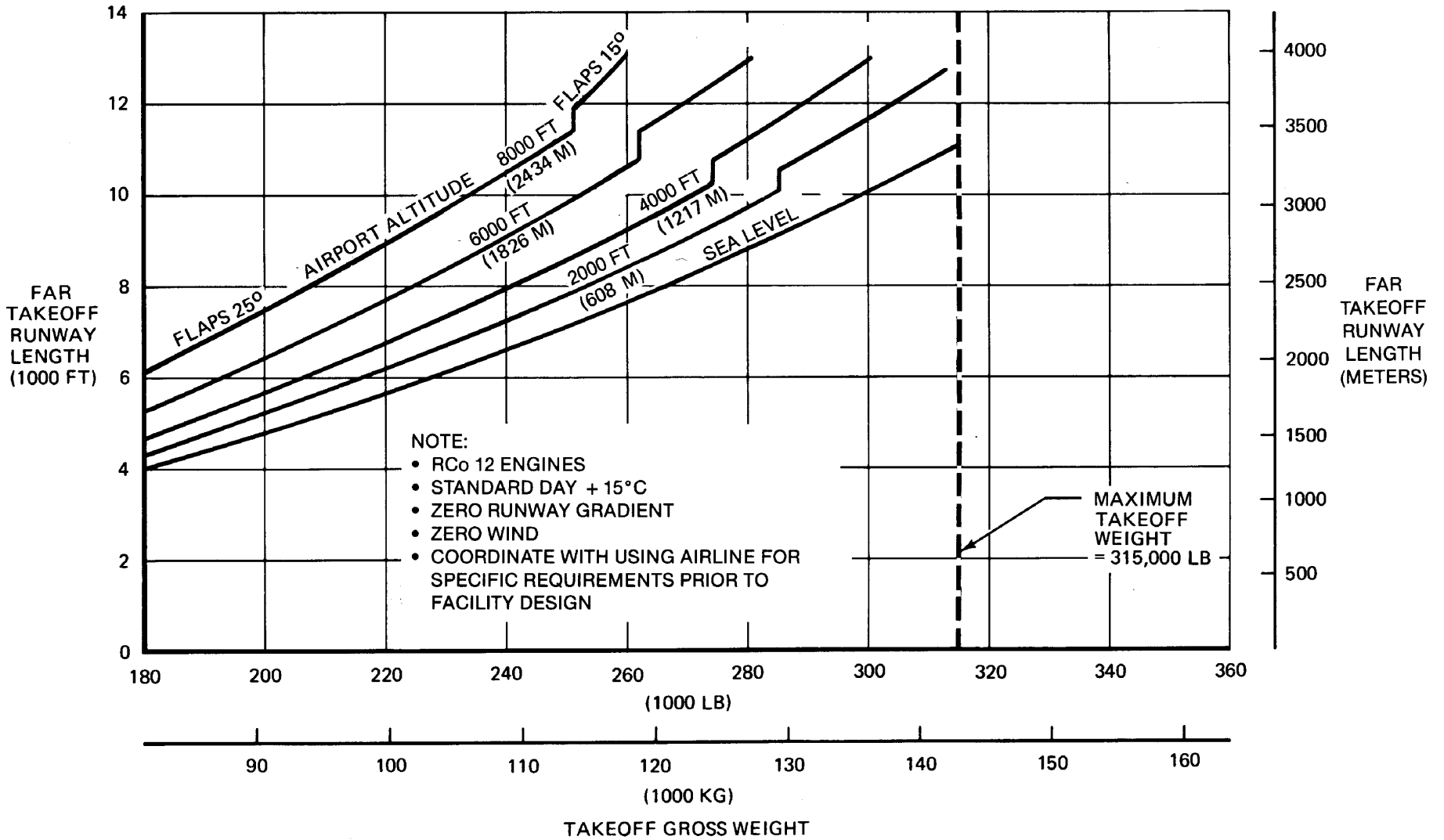

3.3 FAR TAKEOFF RUNWAY LENGTH REQUIREMENTS

3.3.2 STANDARD DAY + 15°C

MODEL DC-8-43

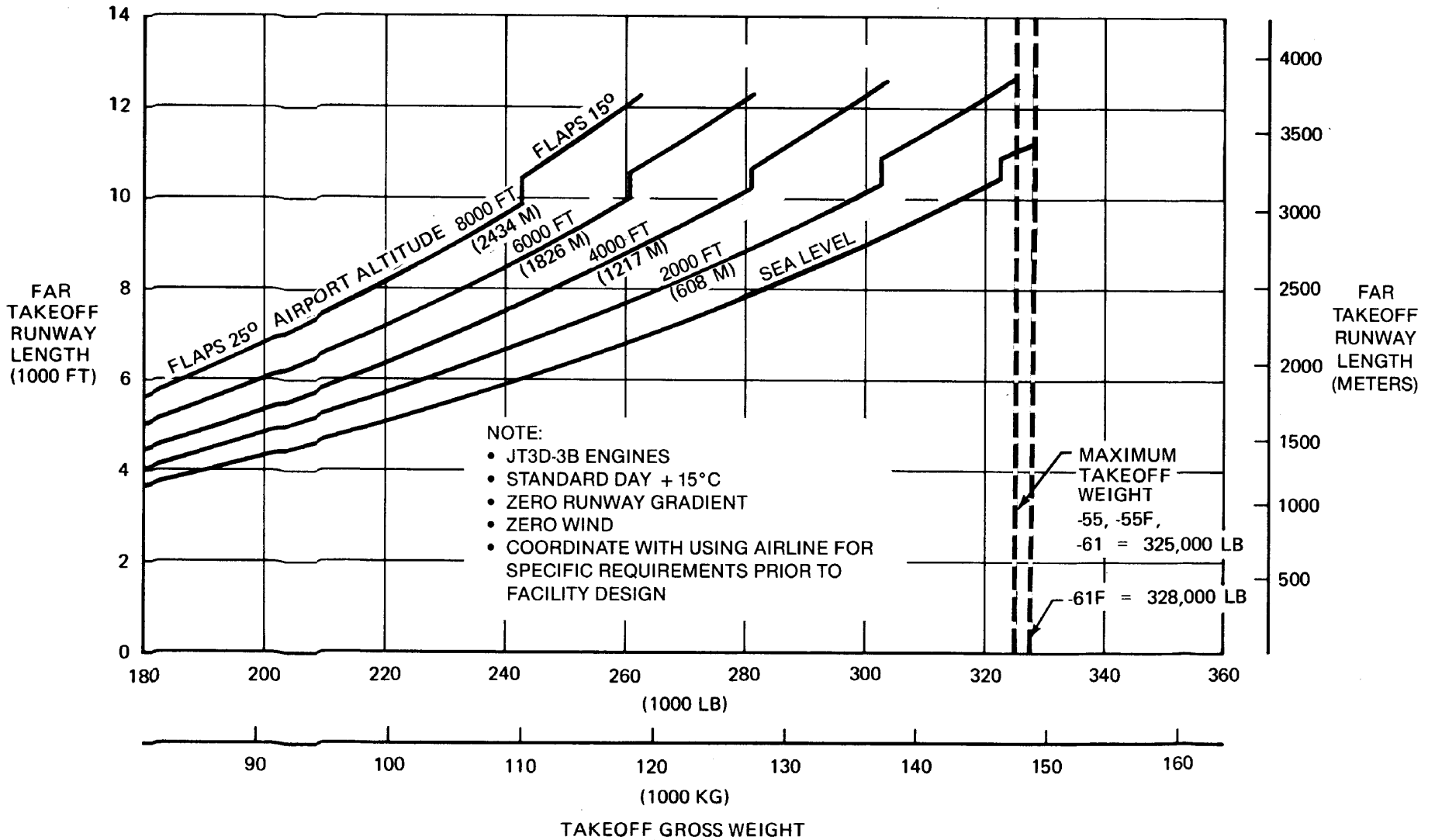

3.3 FAR TAKEOFF RUNWAY LENGTH REQUIREMENTS
 3.3.2 STANDARD DAY + 15°C
 MODEL DC-8-55, -55F, -61, -61F

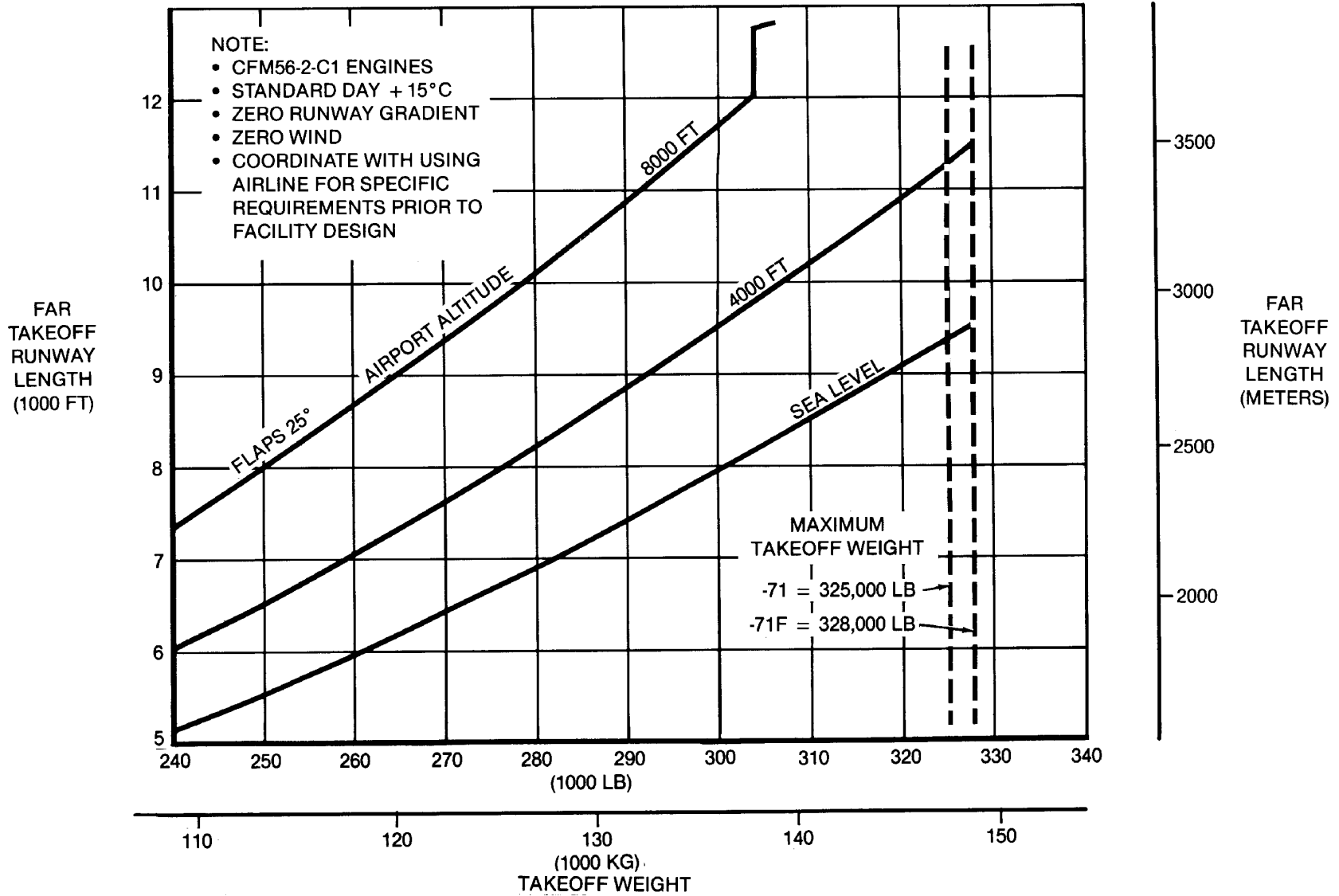

3.3 FAR TAKEOFF RUNWAY LENGTH REQUIREMENTS
3.3.2 STANDARD DAY + 15°C
MODEL DC-8-71, -71F

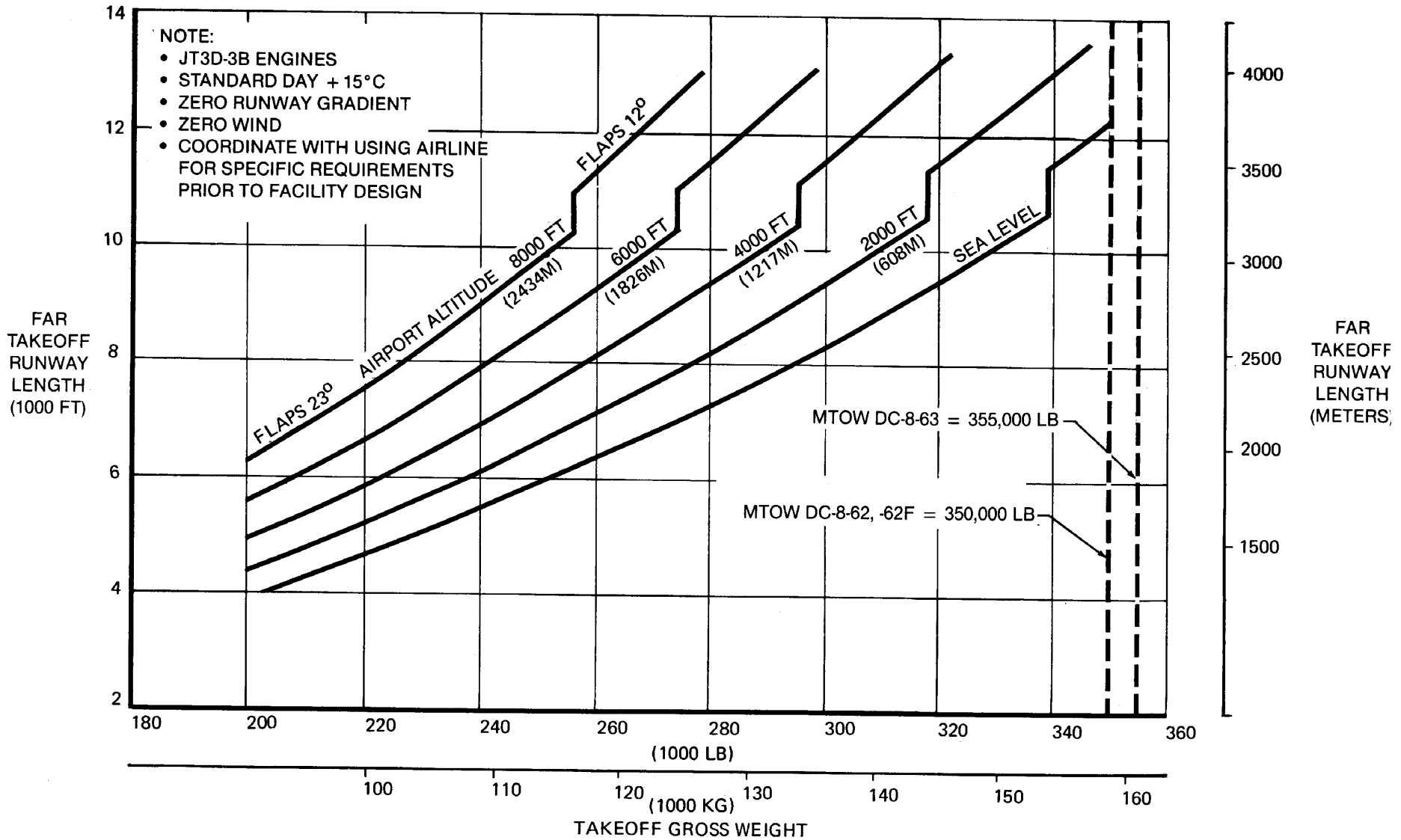

3.3 FAR TAKEOFF RUNWAY LENGTH REQUIREMENTS
3.3.2 STANDARD DAY + 15°C
MODEL DC-8-62, -62F, -63

Not Subject to FAR or ITAR. Copyright © 2023 Boeing. All Rights Reserved.

80

REV A

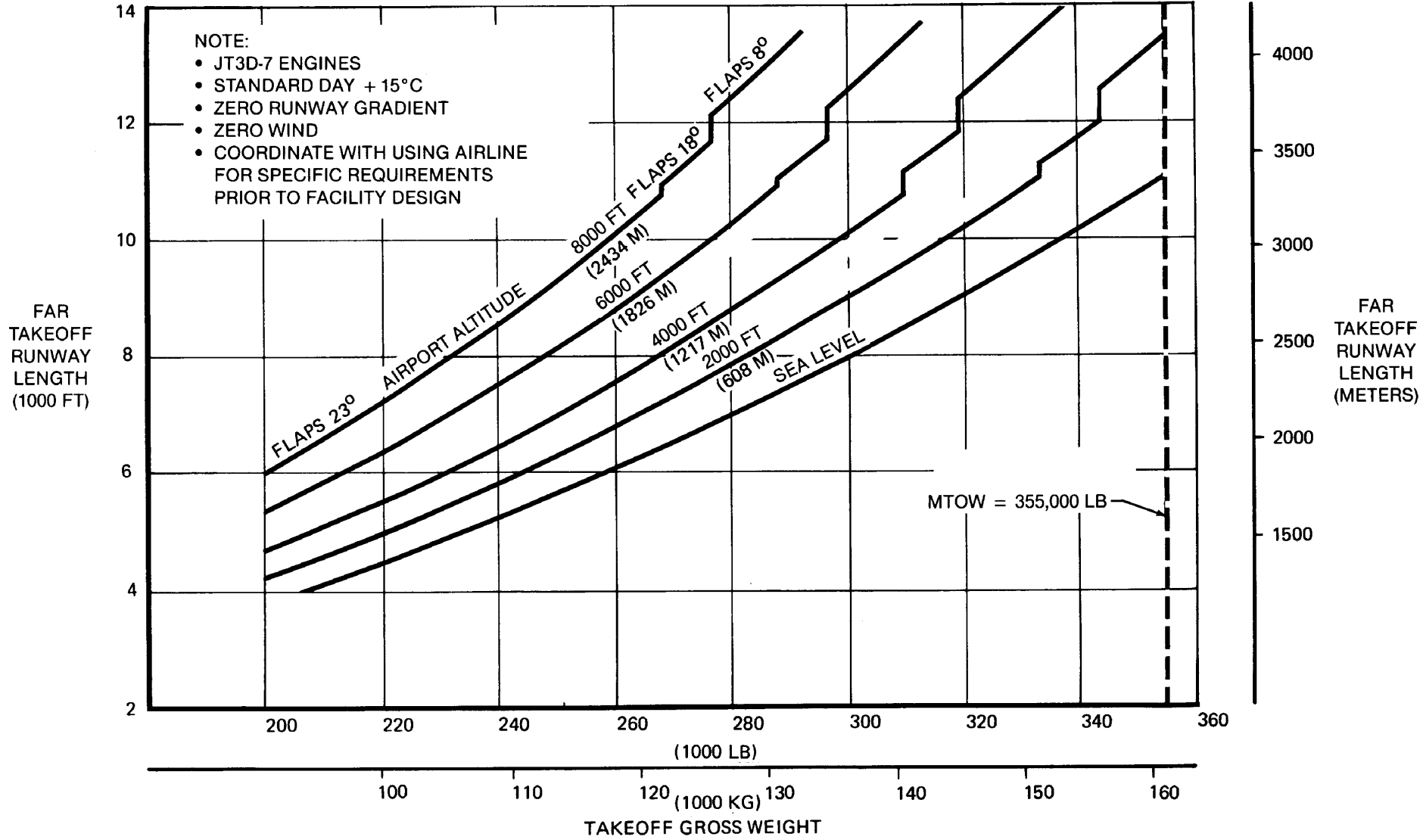

3.3 FAR TAKEOFF RUNWAY LENGTH REQUIREMENTS
3.3.2 STANDARD DAY + 15°C
MODEL DC-8-63F

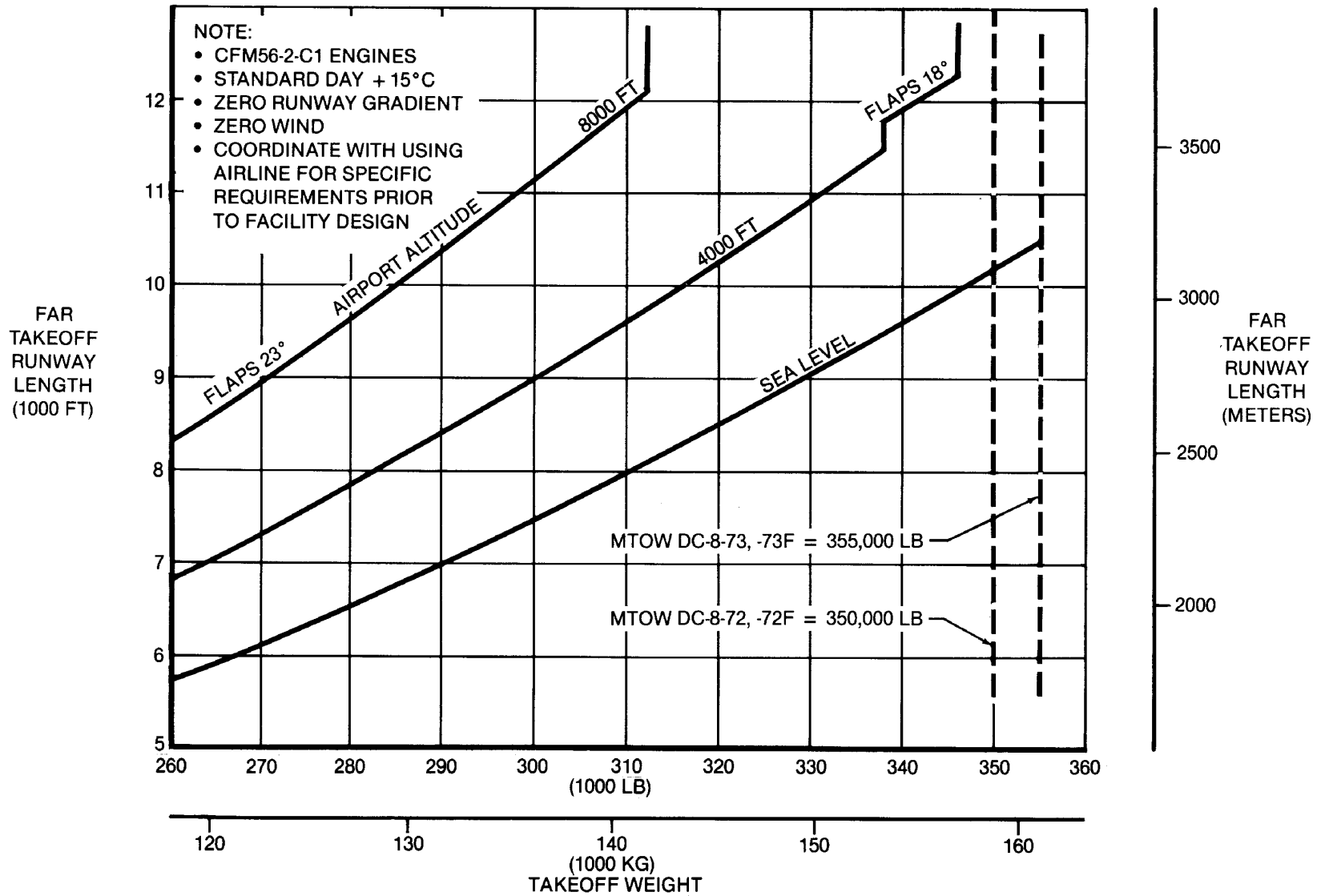

3.3 FAR TAKEOFF RUNWAY LENGTH REQUIREMENTS
3.3.2 STANDARD DAY + 15°C
MODEL DC-8-72, -72F, -73, -73F

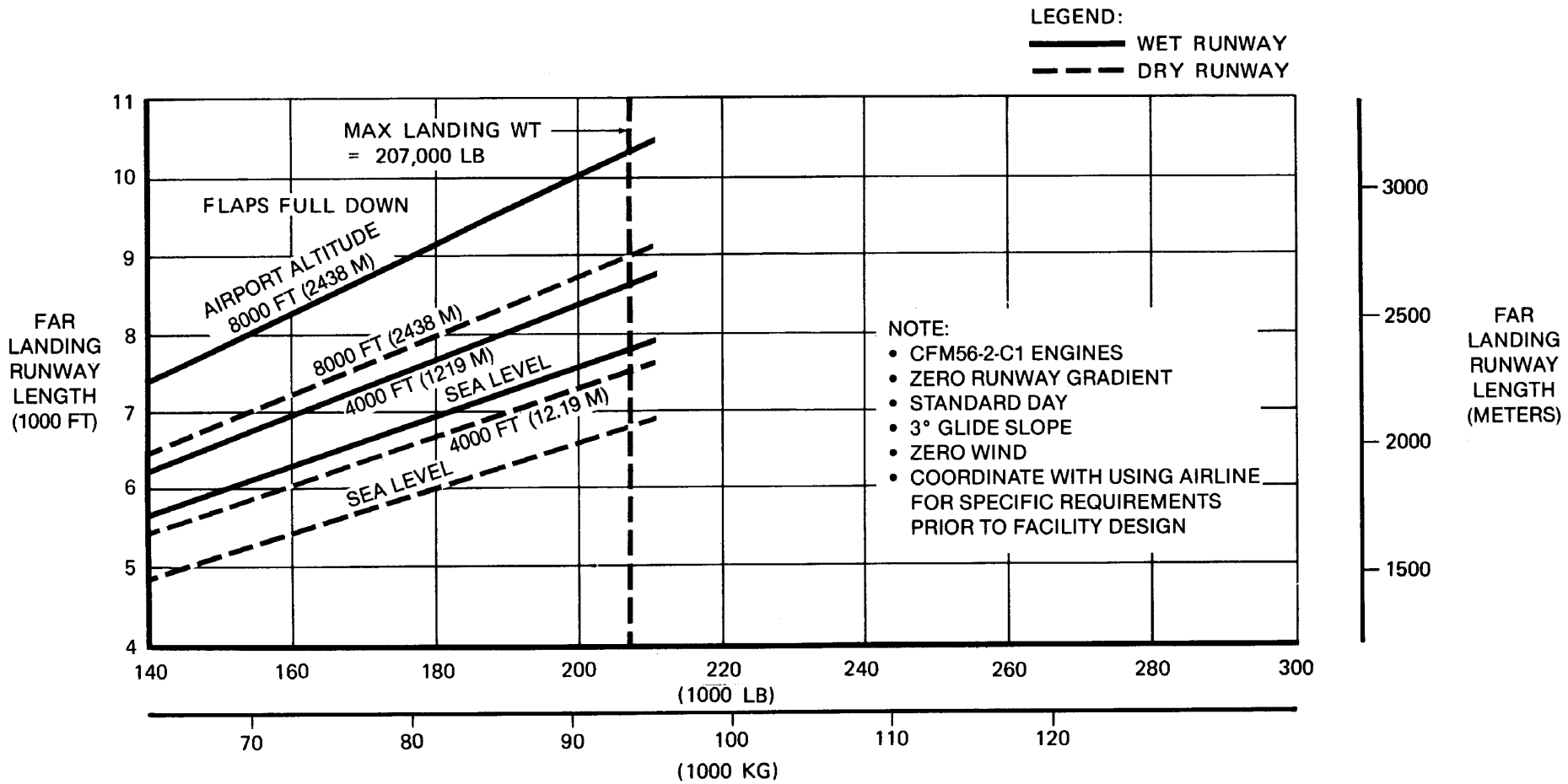

LANDING WEIGHT

3.4 FAR LANDING RUNWAY LENGTH REQUIREMENTS

MODEL DC-8-43

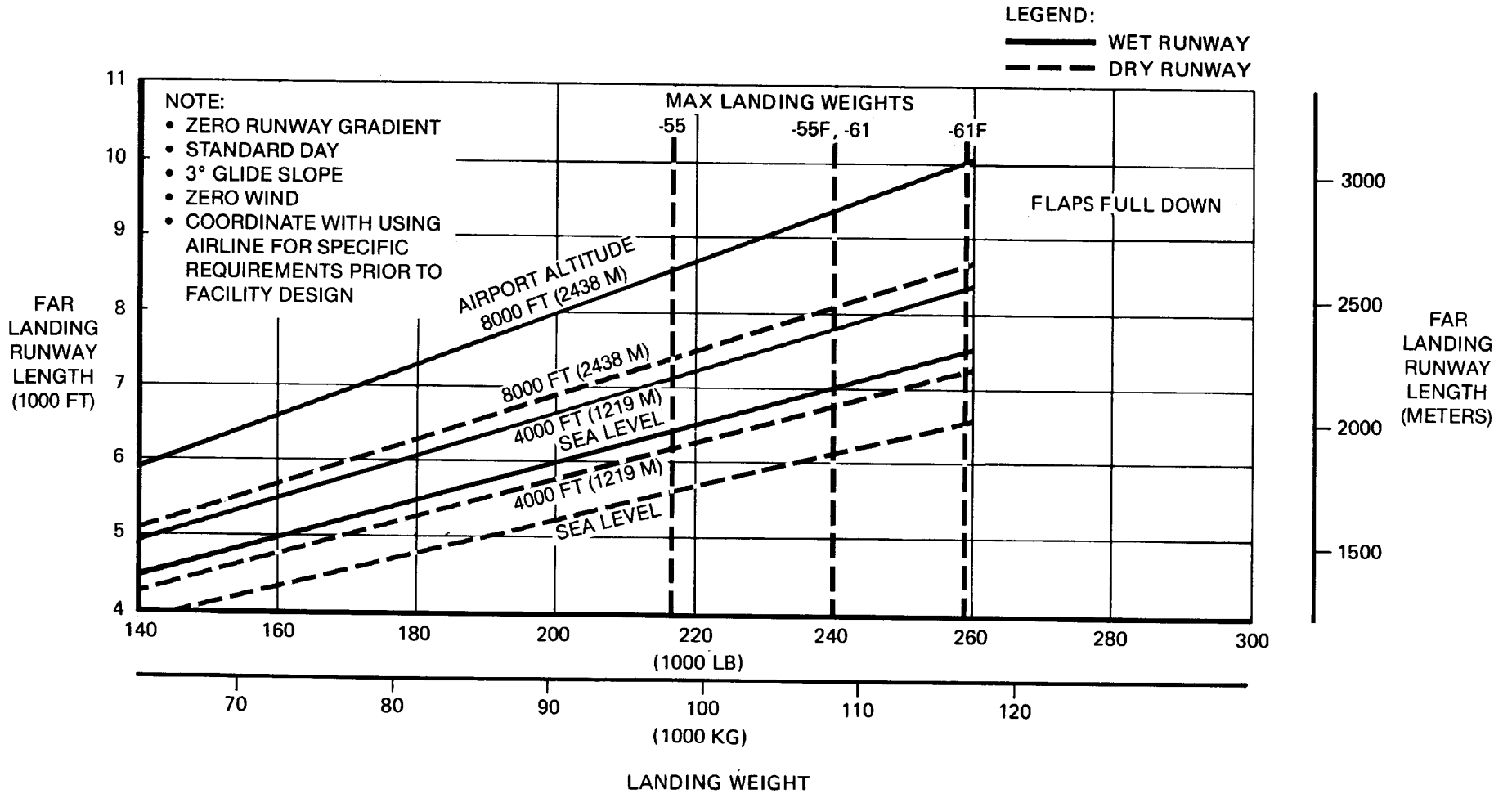

3.4 FAR LANDING RUNWAY LENGTH REQUIREMENTS MODEL DC-8-55, -55F, -61, -61F

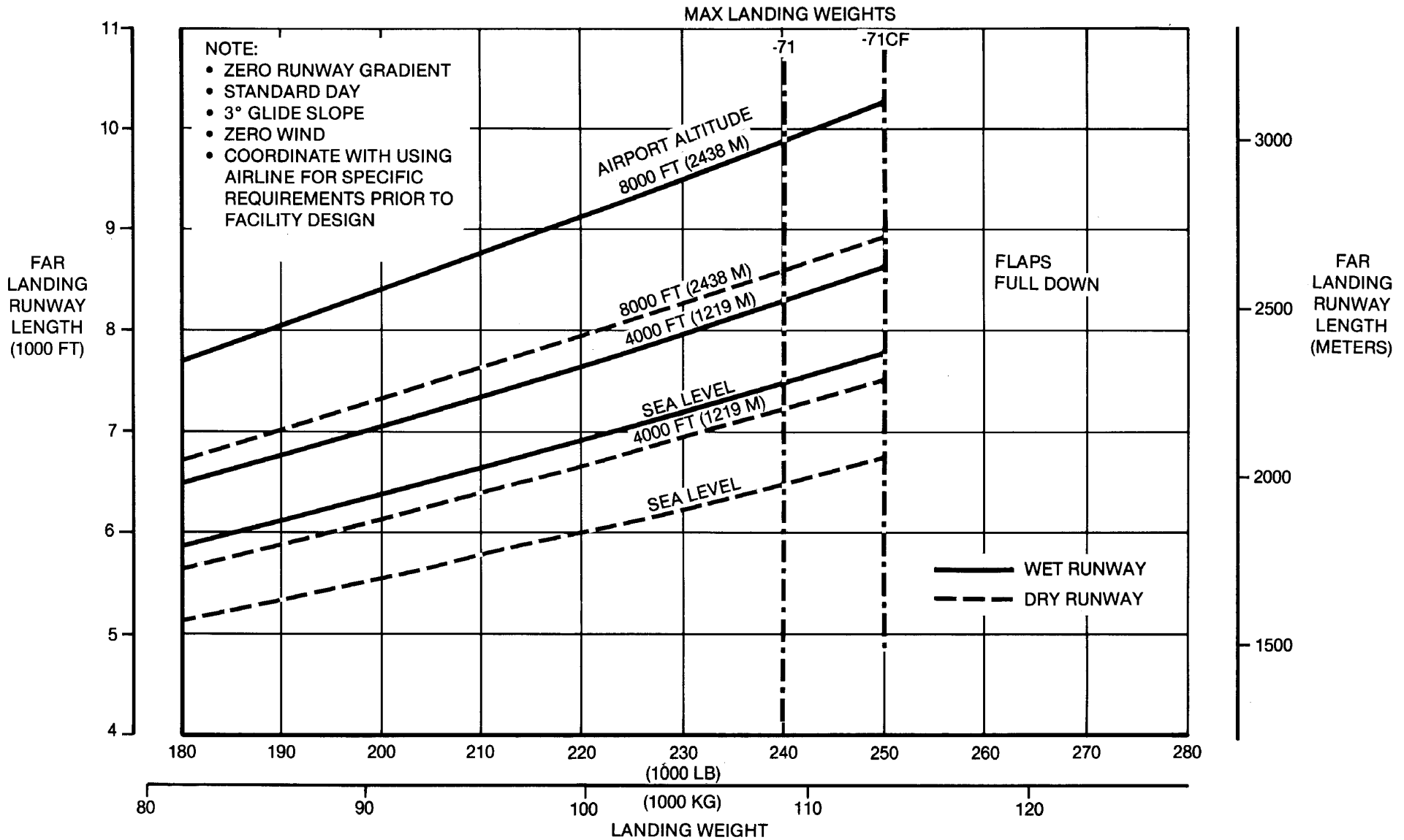

3.4 FAR LANDING RUNWAY LENGTH REQUIREMENTS MODEL DC-8-71, -71F

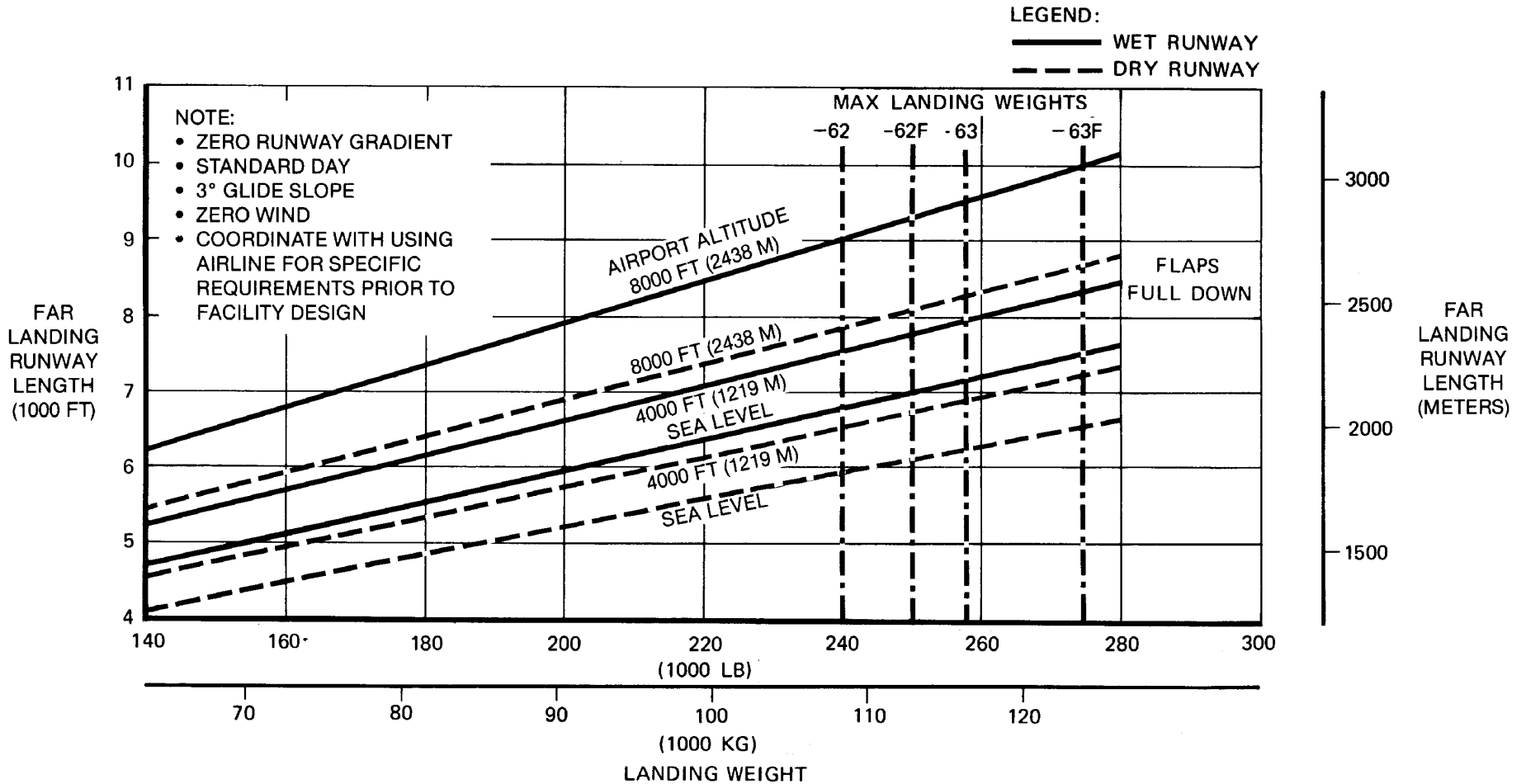

3.4 FAR LANDING RUNWAY LENGTH REQUIREMENTS MODEL DC-8-62, -62F, -63, -63F

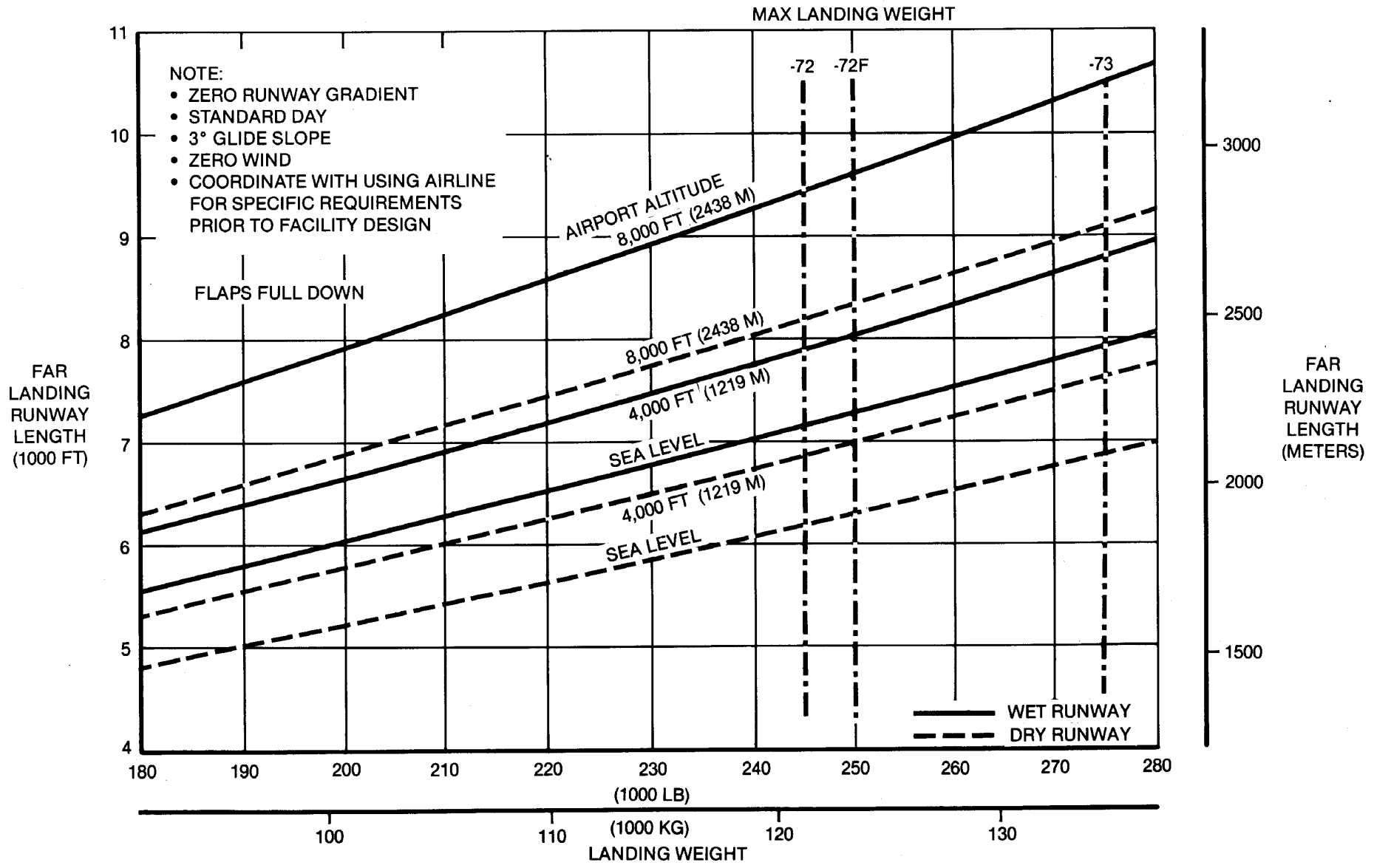

3.4 FAR LANDING RUNWAY LENGTH REQUIREMENTS MODEL DC-8-72, -72F, -73, -73F

Not Subject to FAR or ITAR. Copyright © 2023 Boeing. All Rights Reserved.

86

REV A

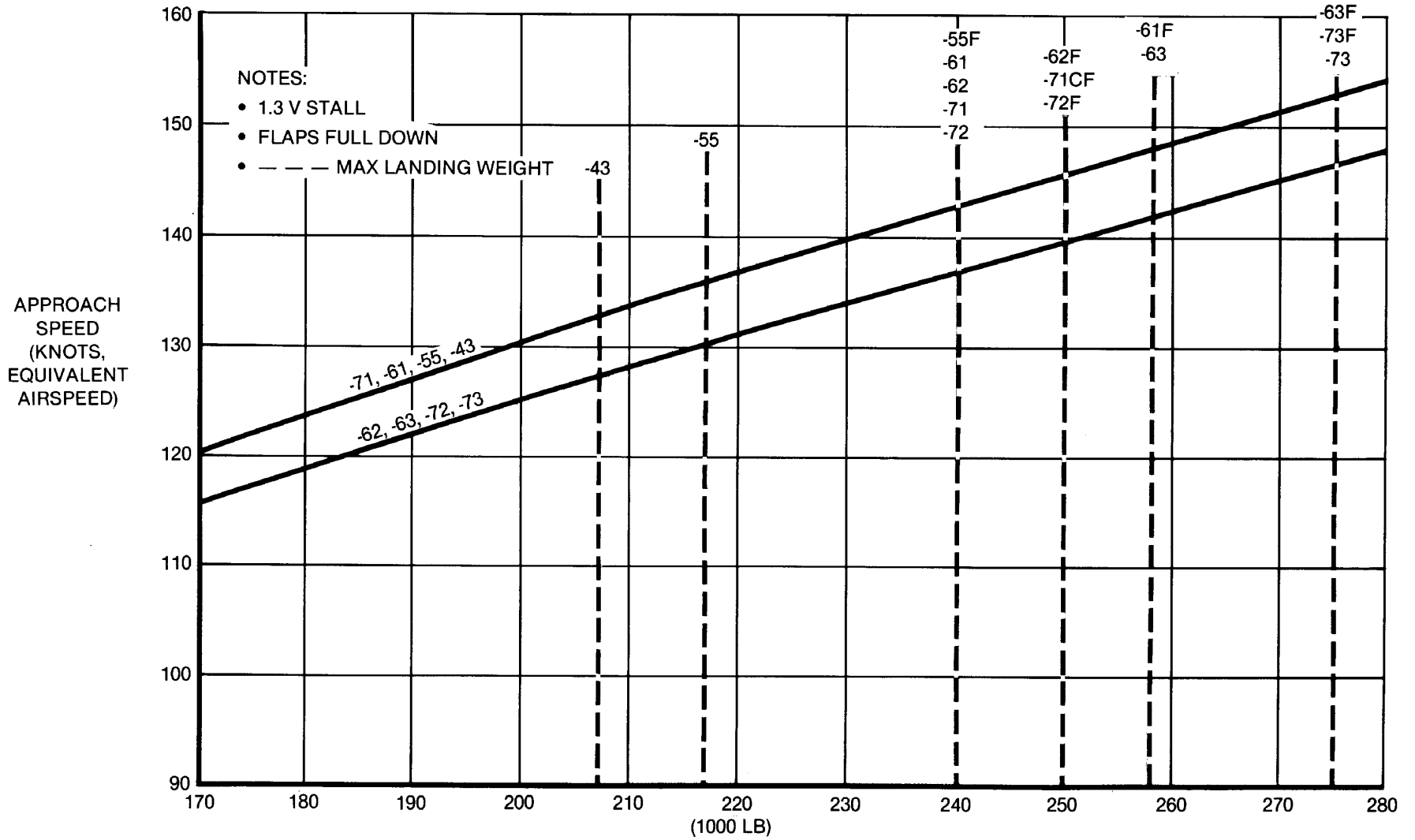

3.5 APPROACH SPEED
MODEL DC-8

4.0 GROUND MANEUVERING

4.1 General Information

This section provides airplane turning capability and maneuvering characteristics.

For ease of presentation, these data have been determined from the theoretical limits imposed by the geometry of the aircraft, and where noted, provide for a normal allowance for tire slippage. As such, they reflect the turning capability of the aircraft in favorable operating circumstances. These data should only be used as guidelines for the method of determination of such parameters and for the maneuvering characteristics of this aircraft type.

In the ground operating mode, varying airline practices may demand that more conservative turning procedures be adopted to avoid excessive tire wear and to reduce possible maintenance problems. Airline operating techniques will vary, in the level of performance, over a wide range of operating circumstances throughout the world. Variations from standard aircraft operating patterns may be necessary to satisfy the physical constraints within the maneuvering area, such as adverse grades, limited area or high risk of jet blast damage. For these reasons, ground maneuvering requirements should be coordinated with the using airlines prior to layout planning.

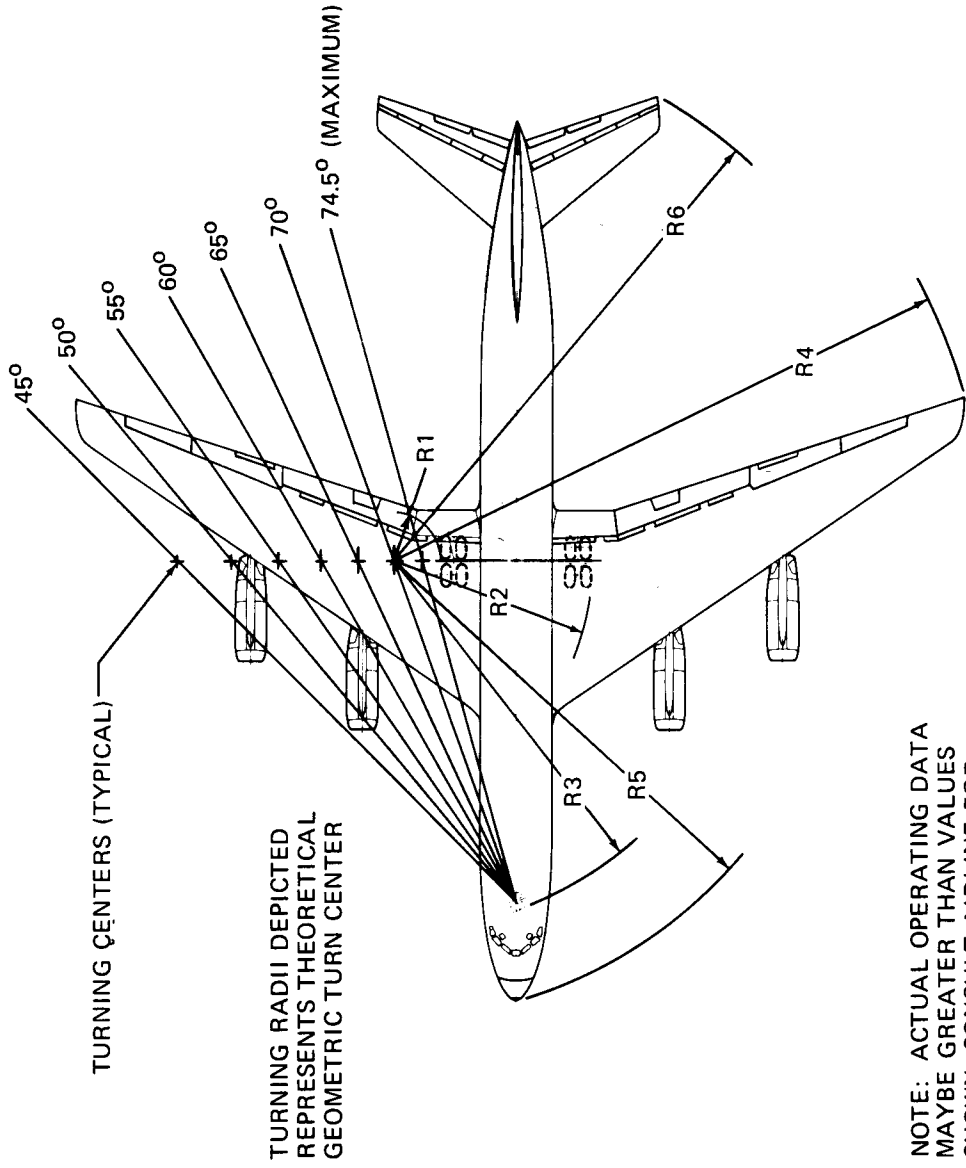

NOTE: ACTUAL OPERATING DATA MAYBE GREATER THAN VALUES SHOWN. CONSULT AIRLINE FOR SPECIFIC DATA.

STEERING ANGLE (DEGREES)	R-1		R-2		R-3		R-4		R-5		R-6	
	FT	M	FT	M	FT	M	FT	M	FT	M	FT	M
30	87.3	26.6	111.9	34.1	115.0	35.1	172.7	52.6	123.7	37.7	145.5	44.3
35	69.8	21.3	94.4	28.8	100.2	30.5	155.5	47.4	110.1	33.6	131.1	39.9
40	56.2	17.1	80.9	24.7	89.5	27.3	142.1	43.3	100.4	30.6	120.4	36.7
45	45.2	13.8	69.8	21.3	81.3	24.8	131.3	40.0	93.2	28.4	112.1	34.2
50	35.9	10.9	60.6	18.5	75.0	22.9	122.2	37.2	87.8	26.8	105.6	32.2
55	27.9	8.5	52.6	16.0	70.2	21.4	114.4	34.9	83.7	25.5	100.3	30.6
60	20.9	6.4	45.5	13.9	66.4	20.2	107.6	32.8	80.6	24.6	96.0	29.3
65	14.5	4.4	39.1	11.9	63.4	19.3	101.4	30.9	78.2	23.8	92.4	28.2
70	8.6	2.6	33.3	10.1	61.2	18.7	95.7	29.2	76.3	23.3	89.3	27.2
74.5 MAXIMUM	3.6	1.1	28.3	8.6	59.7	18.2	90.9	27.7	75.1	22.9	86.9	26.5

4.2 TURNING RADI, NO SLIP ANGLE MODEL DC-8, -43, -55, -55F

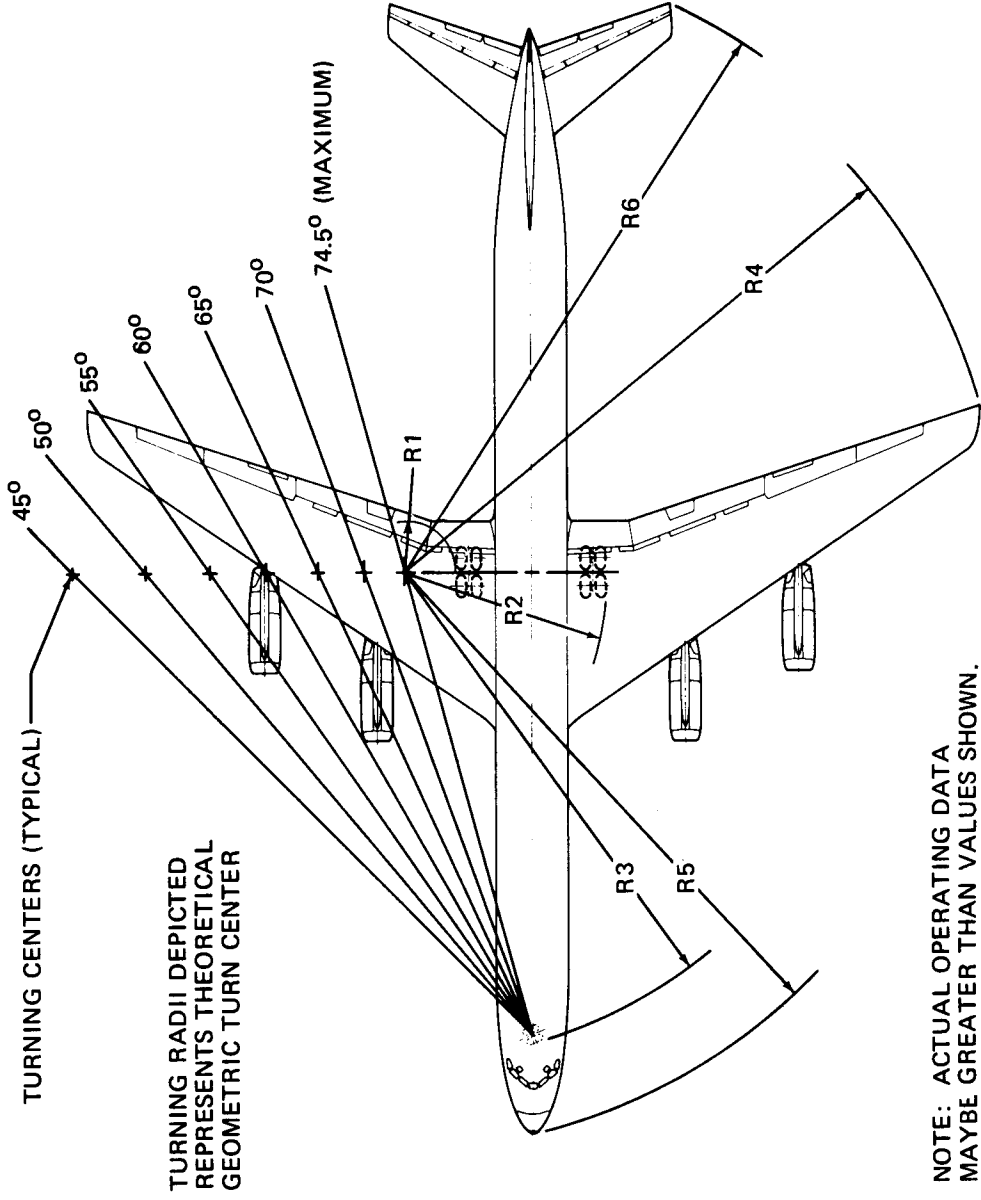

STEERING ANGLE (DEGREES)	R-1		R-2		R-3		R-4		R-5		R-6	
	FT	M	FT	M	FT	M	FT	M	FT	M	FT	M
30	121.9	37.2	146.6	44.7	185.0	56.4	207.0	63.1	163.5	49.8	183.8	56.0
35	98.3	30.0	123.0	37.5	135.1	41.2	183.7	56.0	144.8	44.1	163.9	50.0
40	80.0	24.4	104.7	31.9	120.4	36.7	165.6	50.5	131.4	40.1	149.3	45.5
45	65.2	19.9	89.8	27.4	109.5	33.4	151.0	46.0	121.4	37.0	138.0	42.1
50	52.7	16.1	77.4	23.6	101.0	30.8	138.8	42.3	113.7	34.7	129.2	39.4
55	41.9	12.8	66.6	20.3	94.5	28.8	128.3	39.1	107.9	32.9	122.1	37.2
60	32.4	9.9	57.1	17.4	89.4	27.2	118.9	36.2	103.6	31.6	116.2	35.4
65	23.8	7.3	48.5	14.8	85.4	26.0	110.6	33.7	100.0	30.5	111.4	34.0
70	15.9	4.8	40.5	12.3	82.4	25.1	102.9	31.4	97.5	29.7	107.4	32.7
74.5 (MAXIMUM)	9.2	2.8	33.8	10.3	80.3	24.5	96.5	29.4	95.9	29.2	104.3	31.8

4.2 TURNING RADII, NO SLIP ANGLE MODEL DC-8, -61, -61F, -71, -71F

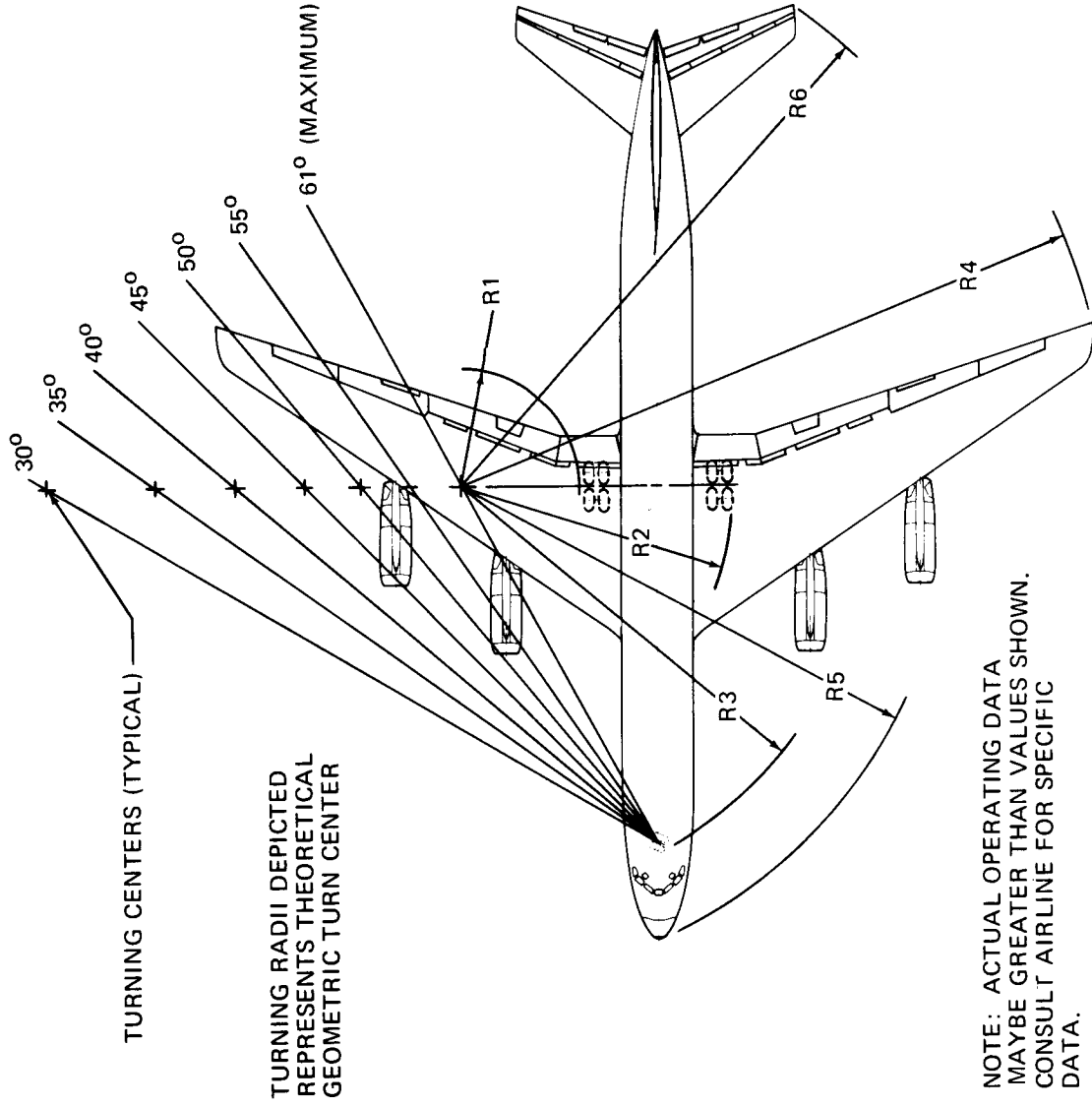

TURNING CENTERS (TYPICAL)

TURNING RADII DEPICTED REPRESENTS THEORETICAL GEOMETRIC TURN CENTER

NOTE: ACTUAL OPERATING DATA MAYBE GREATER THAN VALUES SHOWN. CONSULT AIRLINE FOR SPECIFIC DATA.

STEERING ANGLE (DEGREES)	R-1		R-2		R-3		R-4		R-5		R-6	
	FT	M	FT	M	FT	M	FT	M	FT	M	FT	M
20	154.7	47.2	179.6	54.7	177.8	54.2	242.8	74.0	183.9	56.1	207.2	63.2
25	118.0	36.0	142.9	43.6	143.9	43.9	206.4	62.9	151.3	46.1	174.0	53.0
30	92.9	28.3	117.8	35.9	121.6	37.1	181.5	55.3	130.3	39.7	152.2	46.4
35	74.4	22.7	99.3	30.3	106.0	32.3	163.3	49.8	115.9	35.3	136.9	41.7
40	60.1	18.3	84.9	25.9	94.6	28.8	149.1	45.4	105.6	32.2	125.6	38.3
45	48.4	14.8	73.3	22.3	86.0	26.2	137.7	42.0	97.9	29.8	116.9	35.6
50	38.6	11.8	63.5	19.4	79.4	24.2	128.1	39.0	92.2	28.1	110.0	33.5
55	30.2	9.2	55.0	16.8	74.2	22.6	119.8	36.5	87.8	26.8	104.4	31.8
61 (MAXIMUM)	21.3	6.5	46.2	14.1	69.5	21.2	111.2	33.9	83.8	25.5	99.0	30.2

4.2 TURNING RADII, NO SLIP ANGLE MODEL DC-8, -62, -62F, -72, -72F

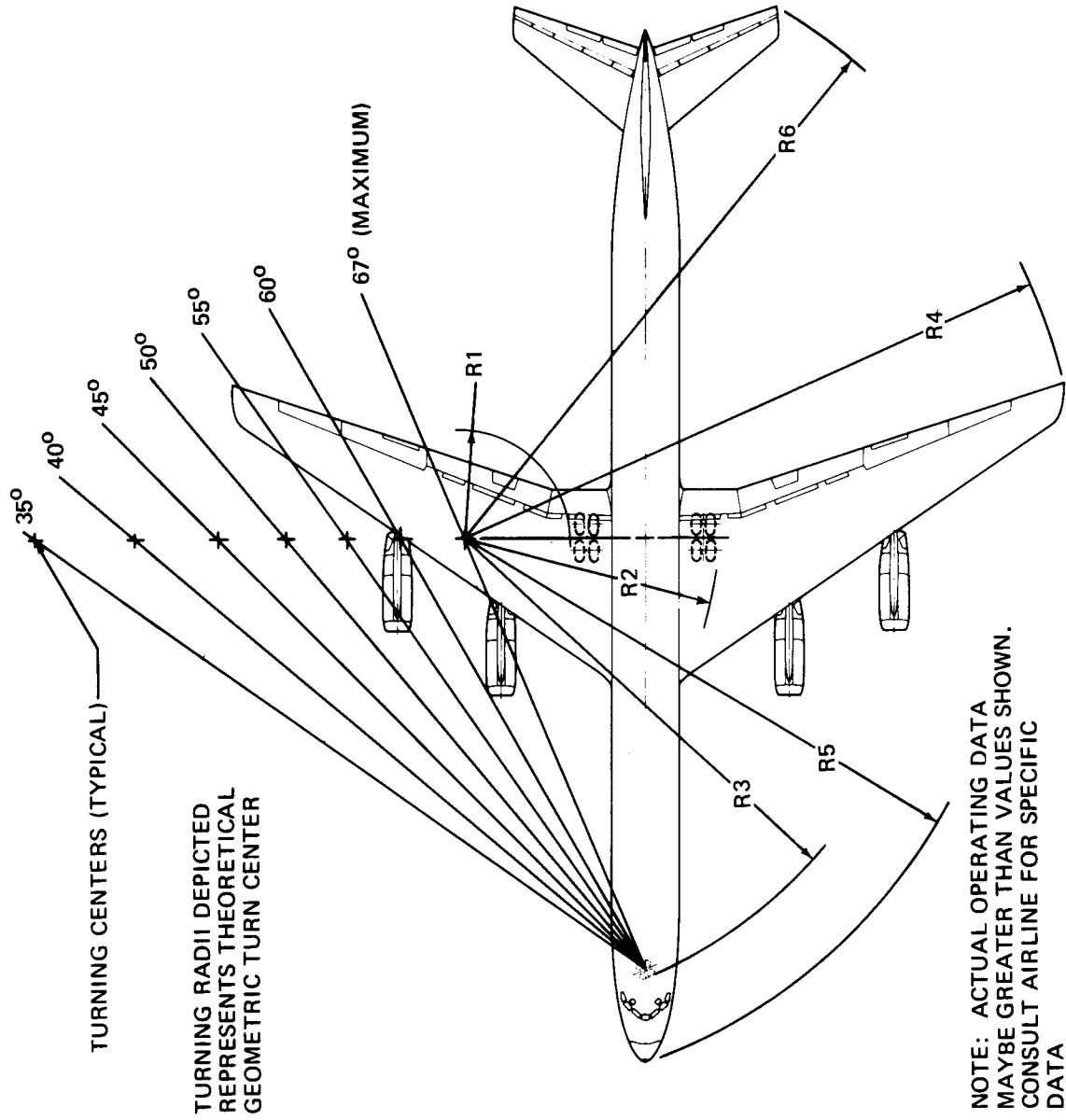

TURNING CENTERS (TYPICAL)

TURNING RADI R1
REPRESENTS THEORETICAL
GEOMETRIC TURN CENTER

NOTE: ACTUAL OPERATING DATA
MAYBE GREATER THAN VALUES SHOWN.
CONSULT AIRLINE FOR SPECIFIC
DATA

STEERING ANGLE (DEGREES)	R-1		R-2		R-3		R-4		R-5		R-6	
	FT	M	FT	M	FT	M	FT	M	FT	M	FT	M
25	153.8	46.9	178.6	54.4	183.3	55.9	241.7	73.7	190.6	58.1	211.9	64.6
30	121.8	37.1	146.7	44.7	155.0	47.2	210.0	64.0	163.5	49.8	183.8	56.0
35	98.2	29.9	123.1	37.5	135.1	41.2	187.8	57.2	144.7	44.1	163.9	50.0
40	79.9	24.4	104.8	31.9	120.5	36.7	168.6	51.4	131.4	40.1	149.3	45.5
45	65.1	19.8	89.9	27.4	109.5	33.4	154.0	46.9	121.4	37.0	138.0	42.1
50	52.6	16.0	77.5	23.6	101.0	30.8	141.7	43.2	113.7	34.7	129.2	39.4
55	41.8	12.7	66.7	20.3	94.5	28.8	131.2	40.0	107.9	32.9	122.1	37.2
60	32.3	9.8	57.2	17.4	89.4	27.2	121.9	37.2	103.5	31.5	116.2	35.4
67 (MAXIMUM)	20.5	6.2	45.3	13.8	84.1	25.6	110.4	33.6	99.0	30.2	109.7	33.4

4.2 TURNING RADI, NO SLIP ANGLE MODEL DC-8, -63, -63F, 73, -73F

NOTE: 5.5° SLIP ANGLE ASSUMED FOR
74.5° NOSE WHEEL DEFLECTION.
CONSULT AIRLINE FOR SPECIFIC
OPERATING DATA.

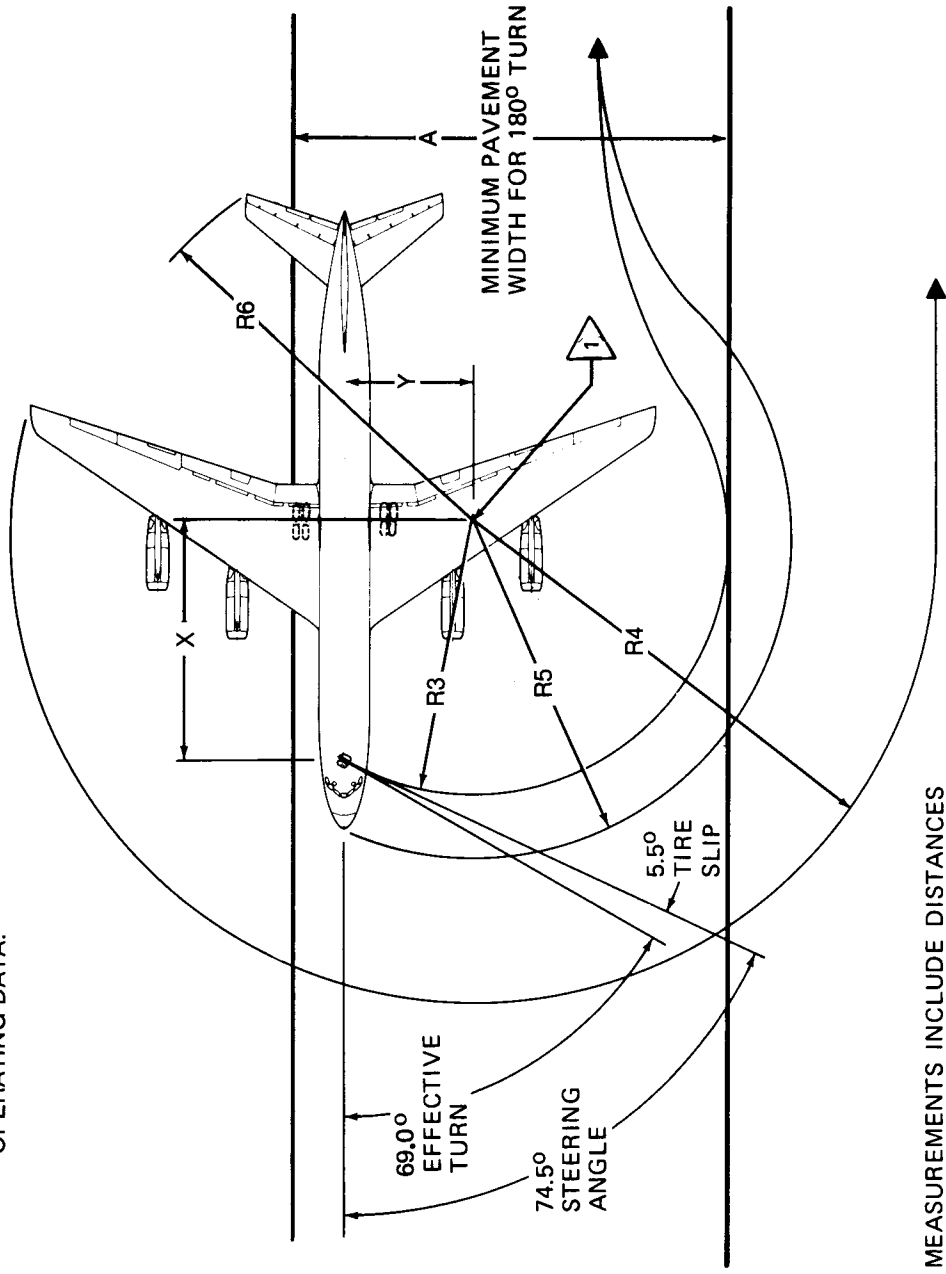

MEASUREMENTS INCLUDE DISTANCES
TO OUTSIDE FACE OF NOSE AND MAIN
LANDING GEAR TIRES.



1 THEORETICAL CENTER OF TURN FOR
MINIMUM TURNING RADIUS. TURN INITIATED
WITH AIRCRAFT IN MOTION, APPROXIMATELY IDLE
THRUST ON ALL ENGINES WITH NO DIFFERENTIAL BRAKING.

IDENTITY	X		Y		A		R3		R4		R5		R6	
	FT	M	FT	M	FT	M	FT	M	FT	M	FT	M	FT	M
DC-8-43, -55-5F	57.5	17.5	22.1	6.7	97.2	29.6	62.8	19.1	96.8	29.5	76.6	23.3	89.9	27.4

4.3 MINIMUM TURNING RADII MODEL DC-8-43, -55, -55F

NOTE: 3.7° SLIP ANGLE ASSUMED FOR
74.5° NOSE WHEEL DEFLECTION.
CONSULT AIRLINE FOR SPECIFIC
OPERATING DATA.

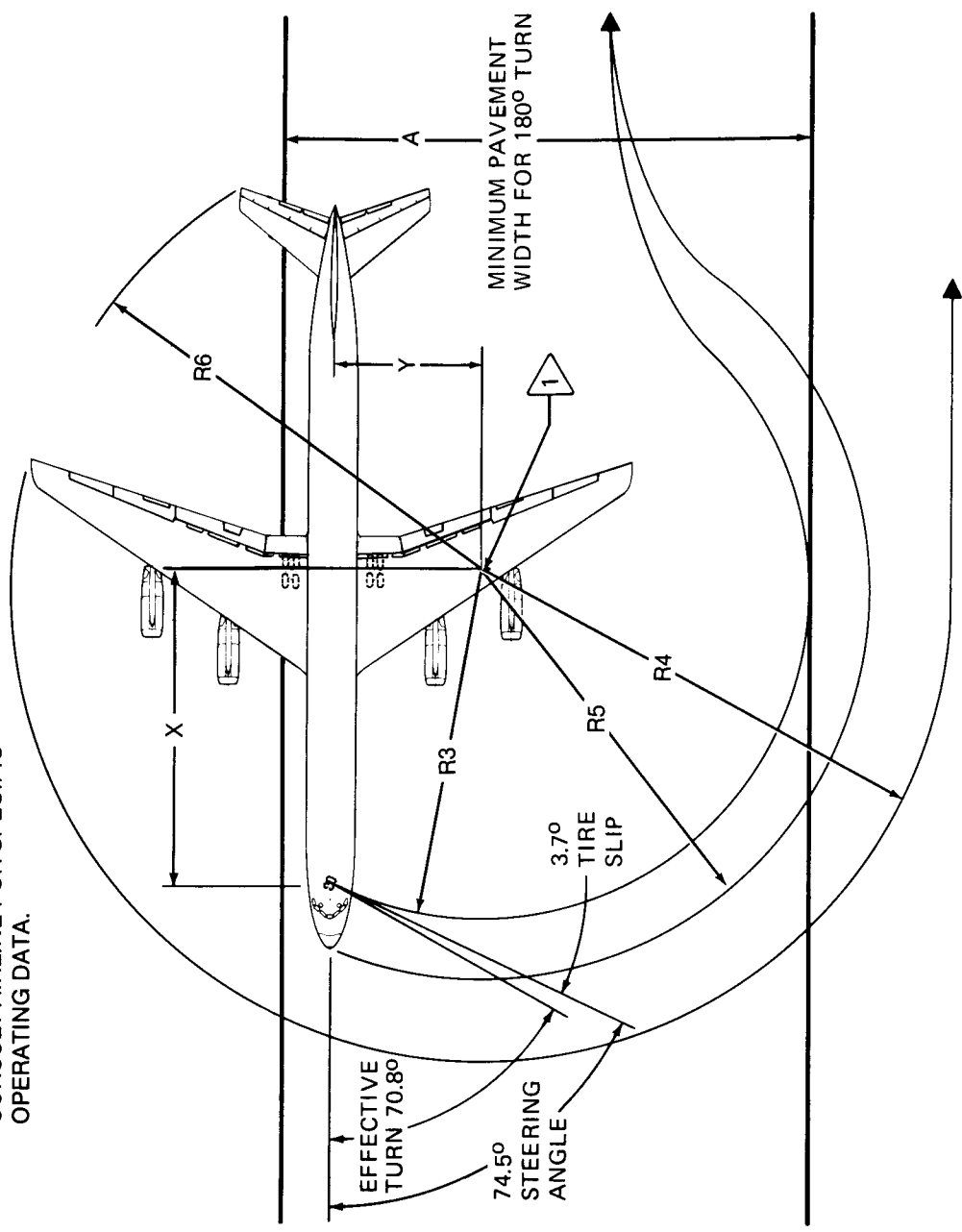

MEASUREMENTS INCLUDE DISTANCES TO
OUTSIDE FACE OF NOSE AND MAIN LANDING
GEAR TIRES.



THEORETICAL CENTER OF TURN FOR
MINIMUM TURNING RADIUS. TURN INITIATED
WITH AIRCRAFT IN MOTION, APPROXIMATELY IDLE
THRUST ON ALL ENGINES WITH NO DIFFERENTIAL BRAKING.

IDENTITY	X	Y	A	R3	R4	R5	R6							
DIMENSIONS	FT	M	FT	M	FT	M	FT							
DC-8-61, -61F, -71, 71F	77.4	23.6	27.0	8.2	122.5	37.3	83.2	25.4	101.8	31.0	97.1	29.6	106.9	32.6

4.3 MINIMUM TURNING RADII MODEL DC-8-61, -61F, -71, -71F

NOTE: 3.5° SLIP ANGLE ASSUMED FOR 61.0° NOSE WHEEL DEFLECTION. CONSULT AIRLINE FOR SPECIFIC OPERATING DATA.

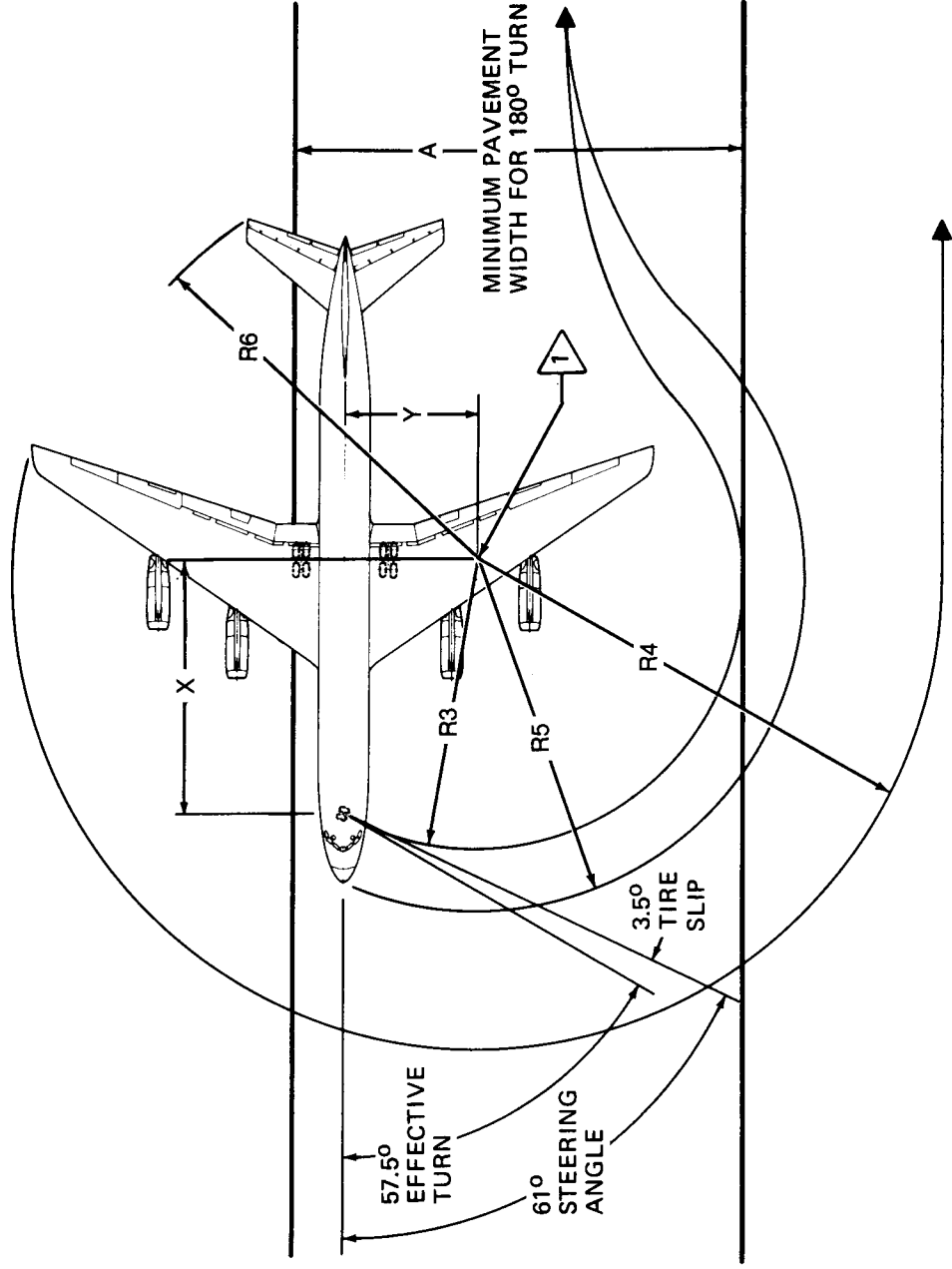

MEASUREMENTS INCLUDE DISTANCES TO OUTSIDE FACE OF NOSE AND MAIN LANDING GEAR TIRES.

 THEORETICAL CENTER OF TURN FOR MINIMUM TURNING RADIUS. TURN INITIATED WITH AIRCRAFT IN MOTION, APPROXIMATELY IDLE THRUST ON ALL ENGINES WITH NO DIFFERENTIAL BRAKING.

IDENTITY	X		Y		A		R3	R4	R5	R6				
	FT	M	FT	M	FT	M					FT	M	FT	M
DC-8-62, -62F, -72, 72F	61.7	18.8	39.3	12.0	126.0	38.4	74.4	22.7	116.4	35.5	87.0	26.5	101.7	31.0

4.3 MINIMUM TURNING RADII MODEL DC-8-62, -62F, -72, -72F

NOTE: 3.6° SLIP ANGLE ASSUMED FOR
67° NOSE WHEEL DEFLECTION.
CONSULT AIRLINE FOR SPECIFIC
OPERATING DATA.

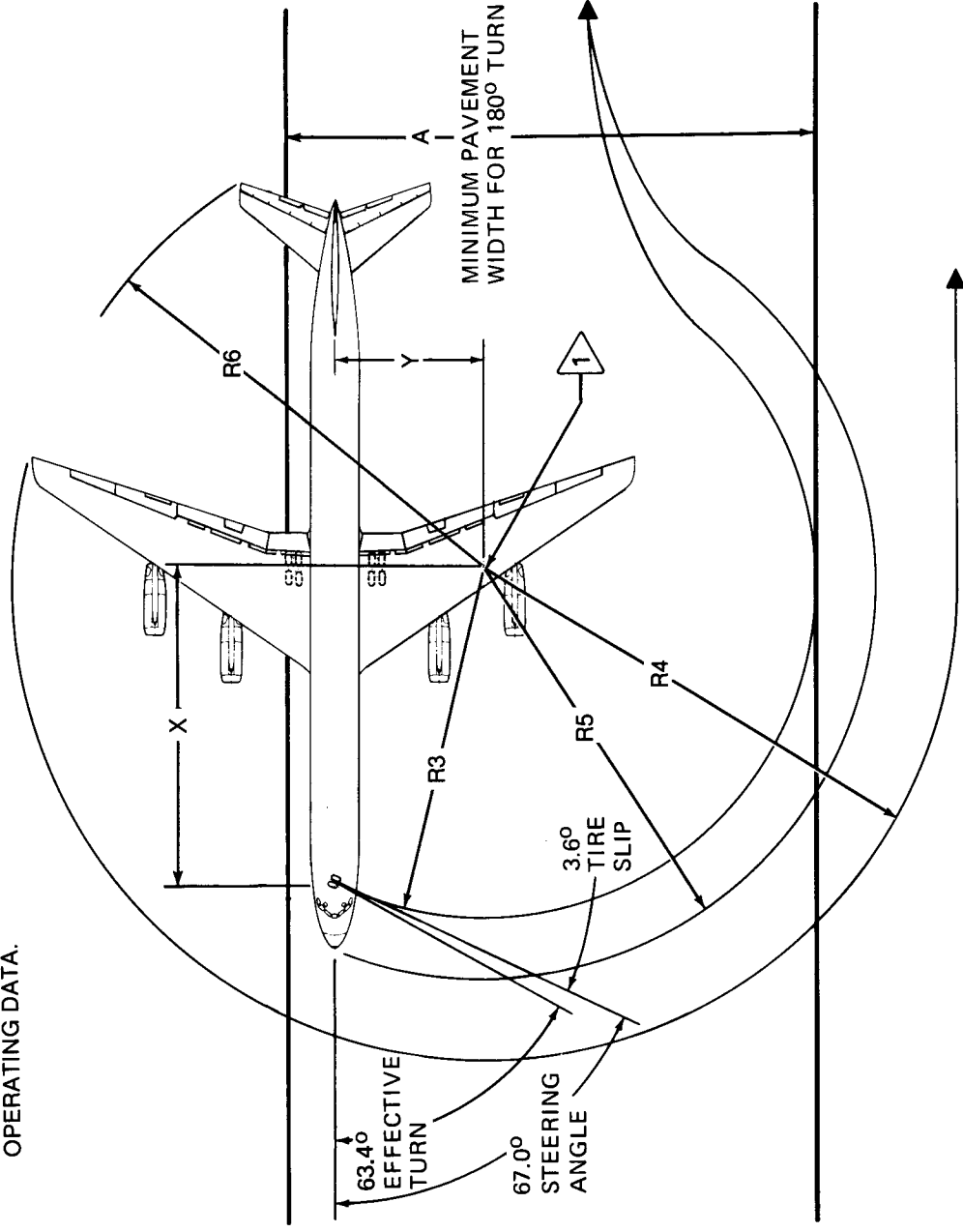

MEASUREMENTS INCLUDE DISTANCES TO
OUTSIDE FACE OF NOSE AND MAIN LANDING
GEAR TIRES.



THEORETICAL CENTER OF TURN FOR
MINIMUM TURNING RADIUS. TURN INITIATED
WITH AIRCRAFT IN MOTION, APPROXIMATELY IDLE
THRUST ON ALL ENGINES WITH NO DIFFERENTIAL BRAKING.

IDENTITY	X		Y		A		R3	R4	R5	R6				
	FT	M	FT	M	FT	M					FT	M	FT	M
DC-8-63, -63F, -73, -73F	77.4	23.6	38.8	11.8	139.0	42.4	87.8	26.8	116.1	35.4	101.0	30.8	113.0	34.4

4.3 MINIMUM TURNING RADII MODEL DC-8-63, -63F, -73, -73F

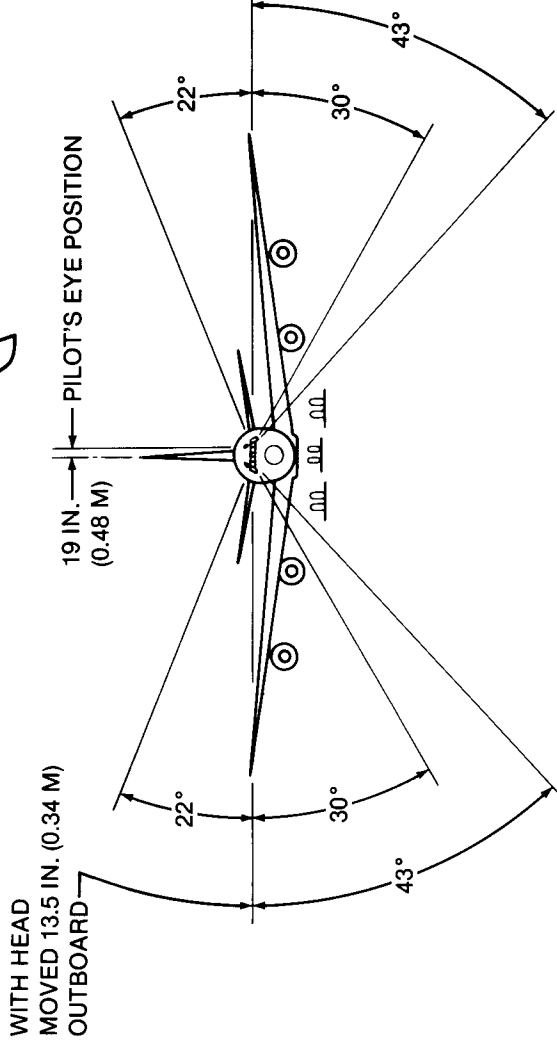
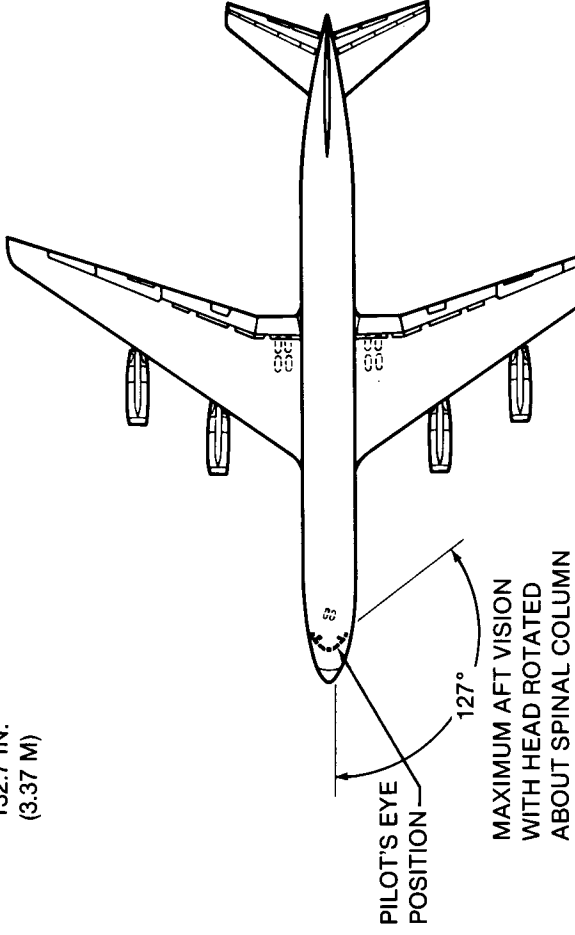
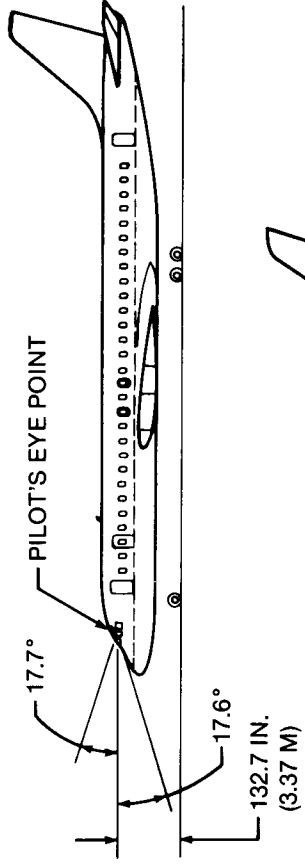

NOT TO BE USED FOR LANDING APPROACH VISIBILITY

4.4 VISIBILITY FROM COCKPIT IN STATIC POSITION MODEL DC-8 SERIES

NOTE: COORDINATE WITH USING AIRLINE FOR SPECIFIC PLANNED OPERATING PROCEDURE.
 NOSE GEAR STEERING ANGLE 20°

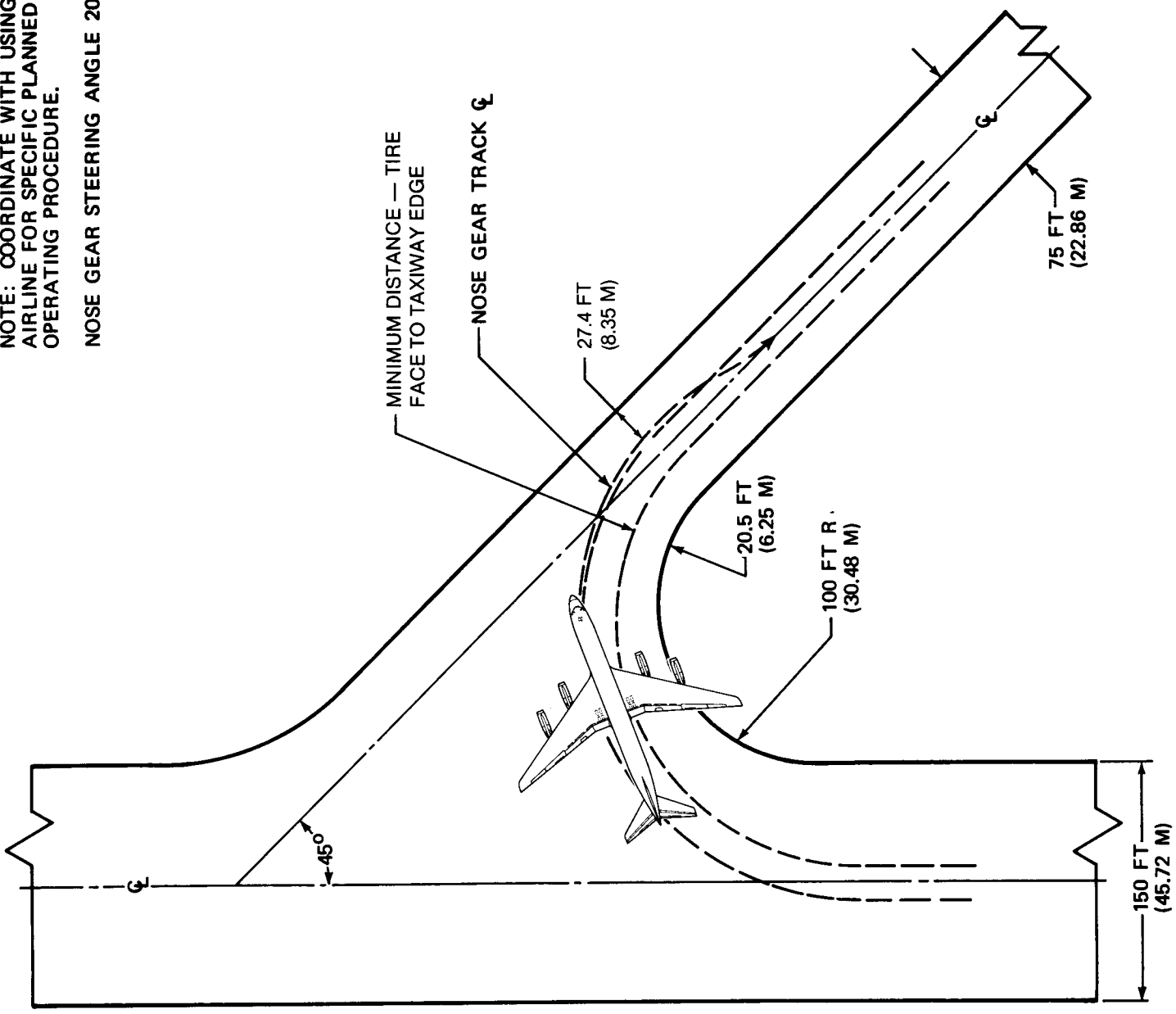

4.5 RUNWAY AND TAXIWAY TURN PATHS
 4.5.1 MORE THAN 90° TURN — RUNWAY TO TAXIWAY
 MODEL DC-8-43, -55, -55F

NOTE: COORDINATE WITH USING AIRLINE FOR SPECIFIC PLANNED OPERATING PROCEDURE.

NOSE GEAR STEERING ANGLE 25°

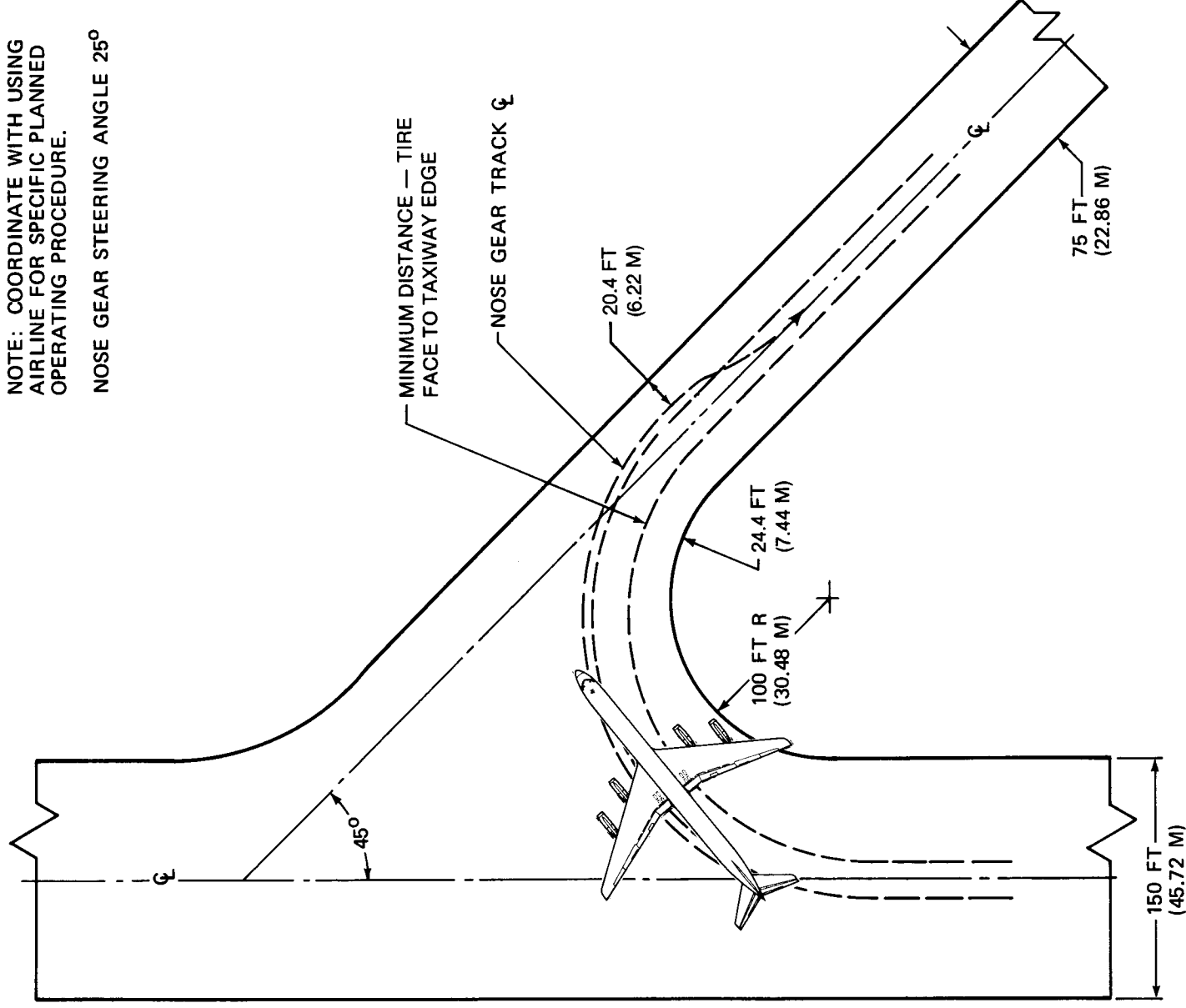

4.5.1 MORE THAN 90° TURN — RUNWAY TO TAXIWAY MODEL DC-8-61, -61F, -71, -71F

NOTE: COORDINATE WITH USING AIRLINE FOR SPECIFIC PLANNED OPERATING PROCEDURE.

NOSE GEAR STEERING ANGLE 20°

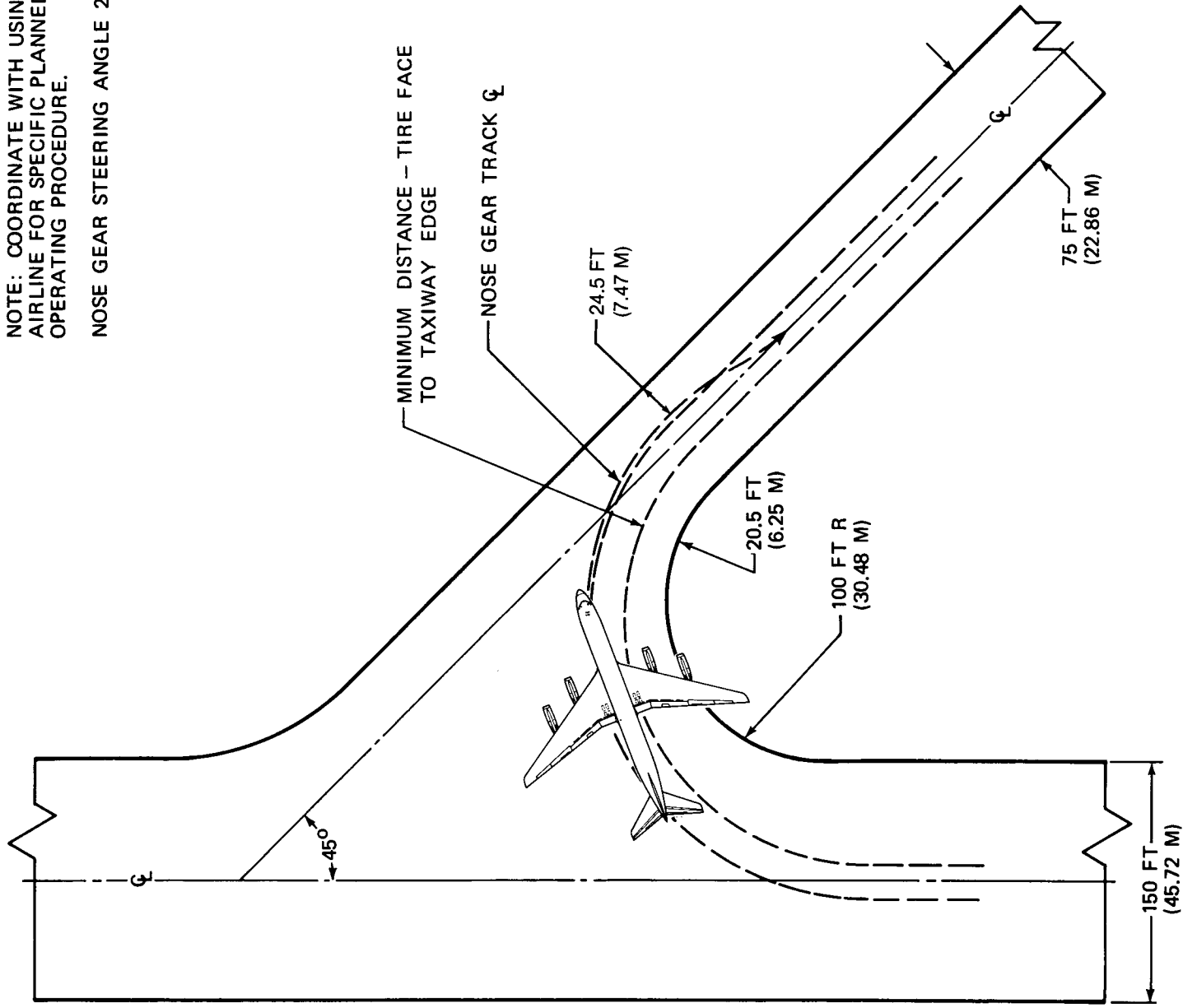

4.5.1 MORE THAN 90° TURN — RUNWAY TO TAXIWAY MODEL DC-8-62, -62F, -72, -72F

NOTE: COORDINATE WITH USING AIRLINE FOR SPECIFIC PLANNED OPERATING PROCEDURE.

NOSE GEAR STEERING ANGLE 25°

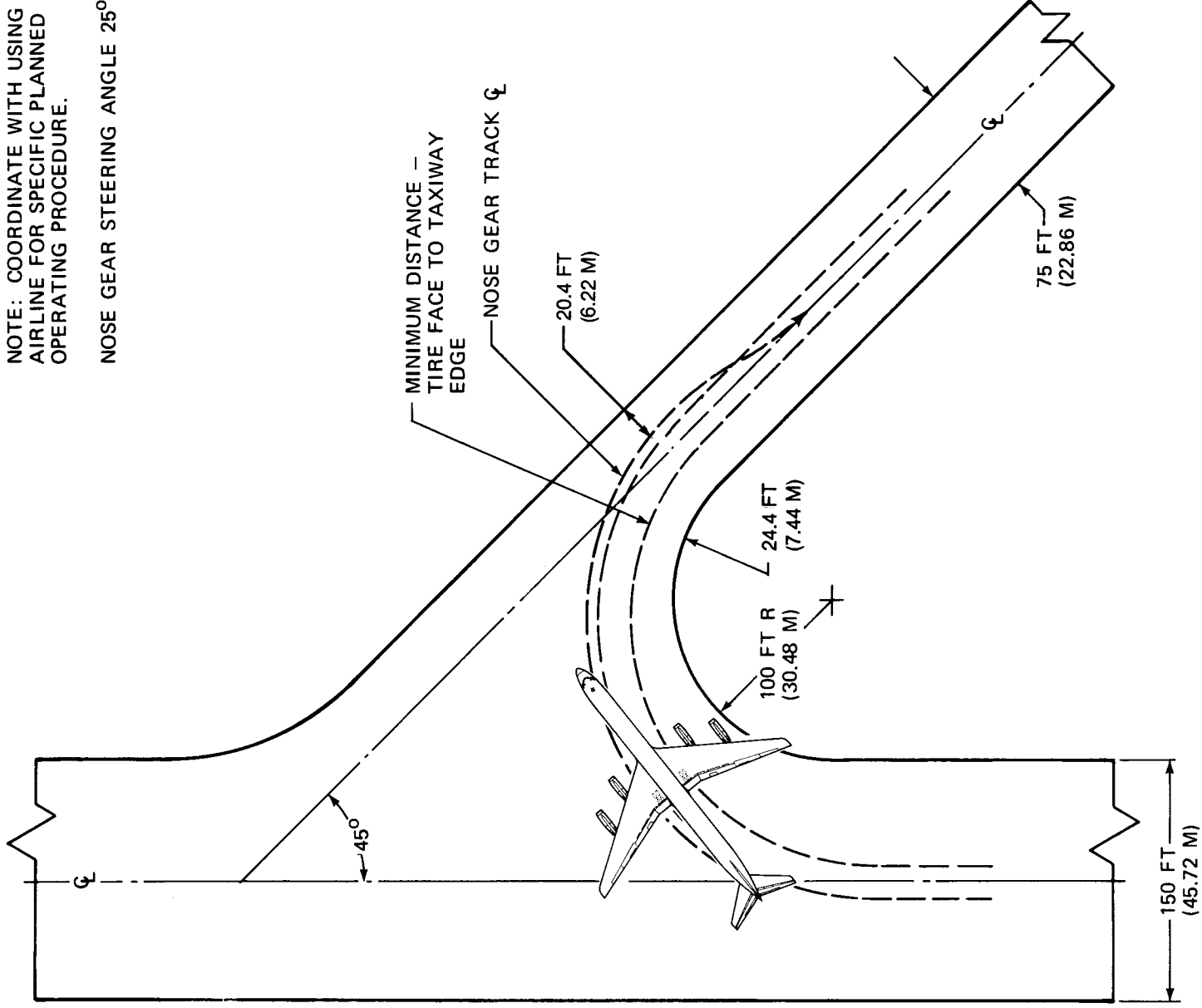

4.5.1 MORE THAN 90° TURN — RUNWAY TO TAXIWAY MODEL DC-8-63, -63F, -73, -73F

NOTE: COORDINATE WITH USING AIRLINE FOR SPECIFIC PLANNED OPERATING PROCEDURE.

NOSE GEAR STEERING ANGLE 25°

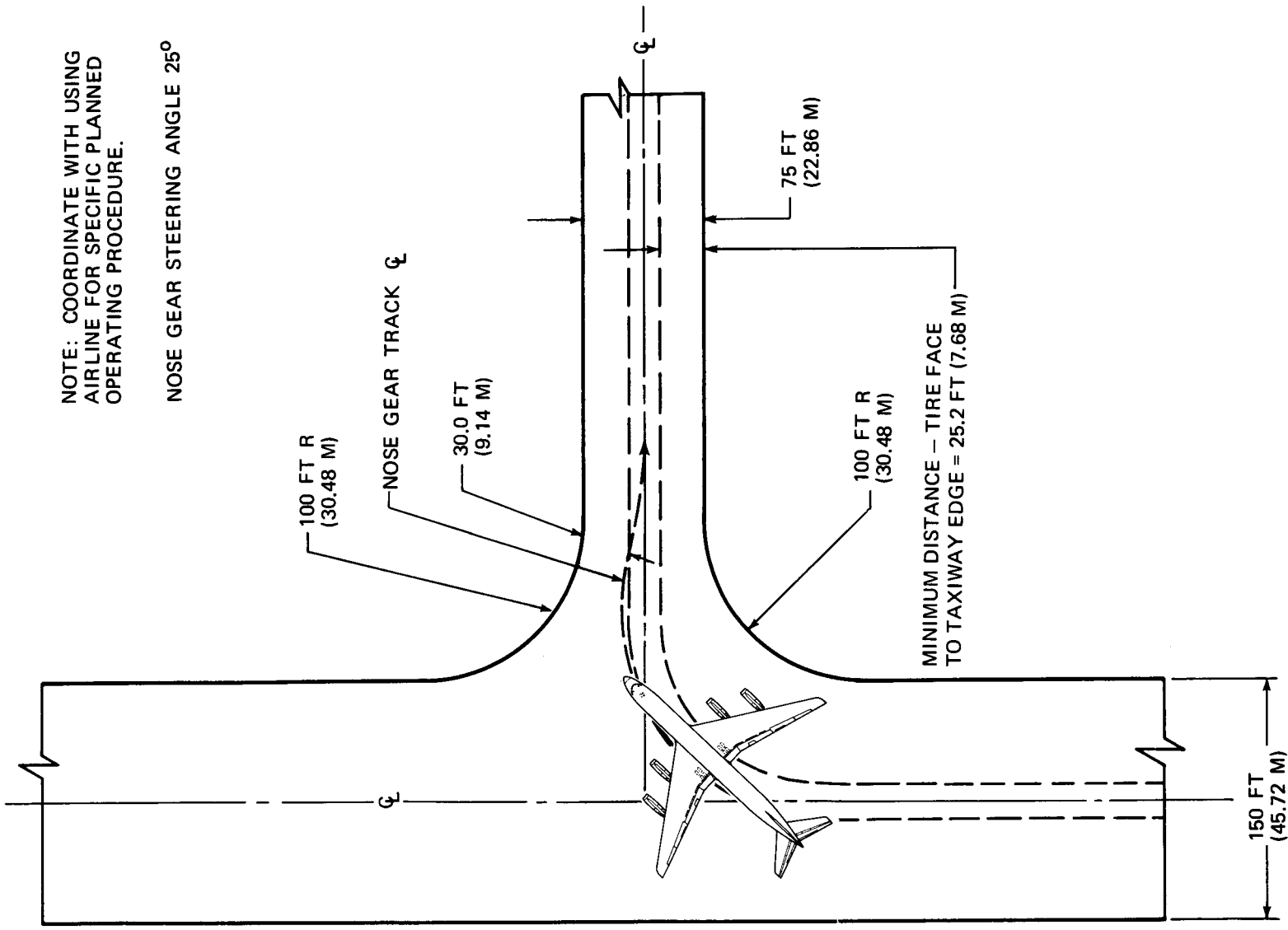

4.5 RUNWAY TO TAXIWAY TURN PATHS

4.5.2 90° TURN — RUNWAY TO TAXIWAY

MODEL DC-8-43, -55, -55F

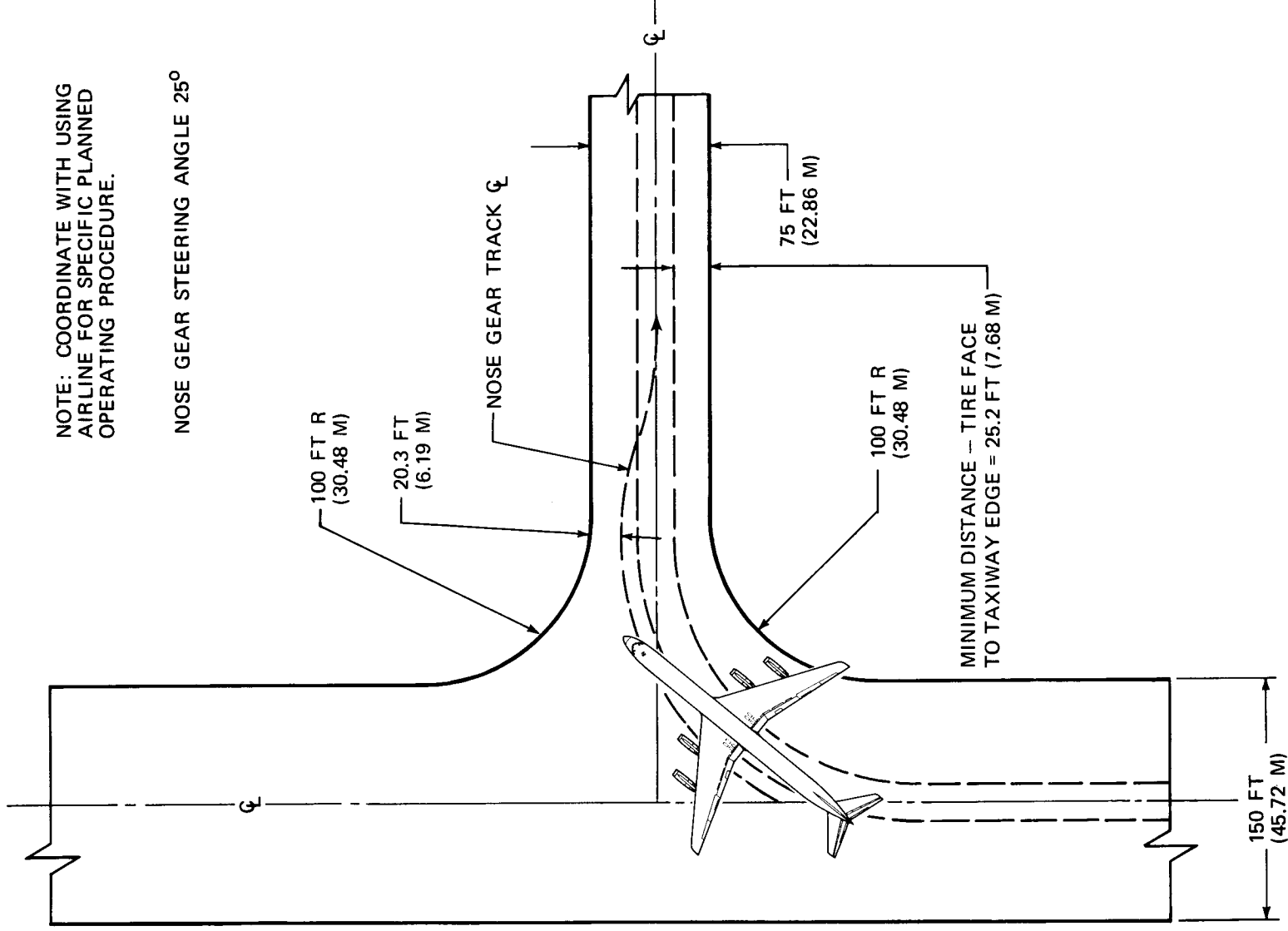

4.5.2 90° TURN – RUNWAY TO TAXIWAY MODEL DC-8-61, -61F, -71, -71F

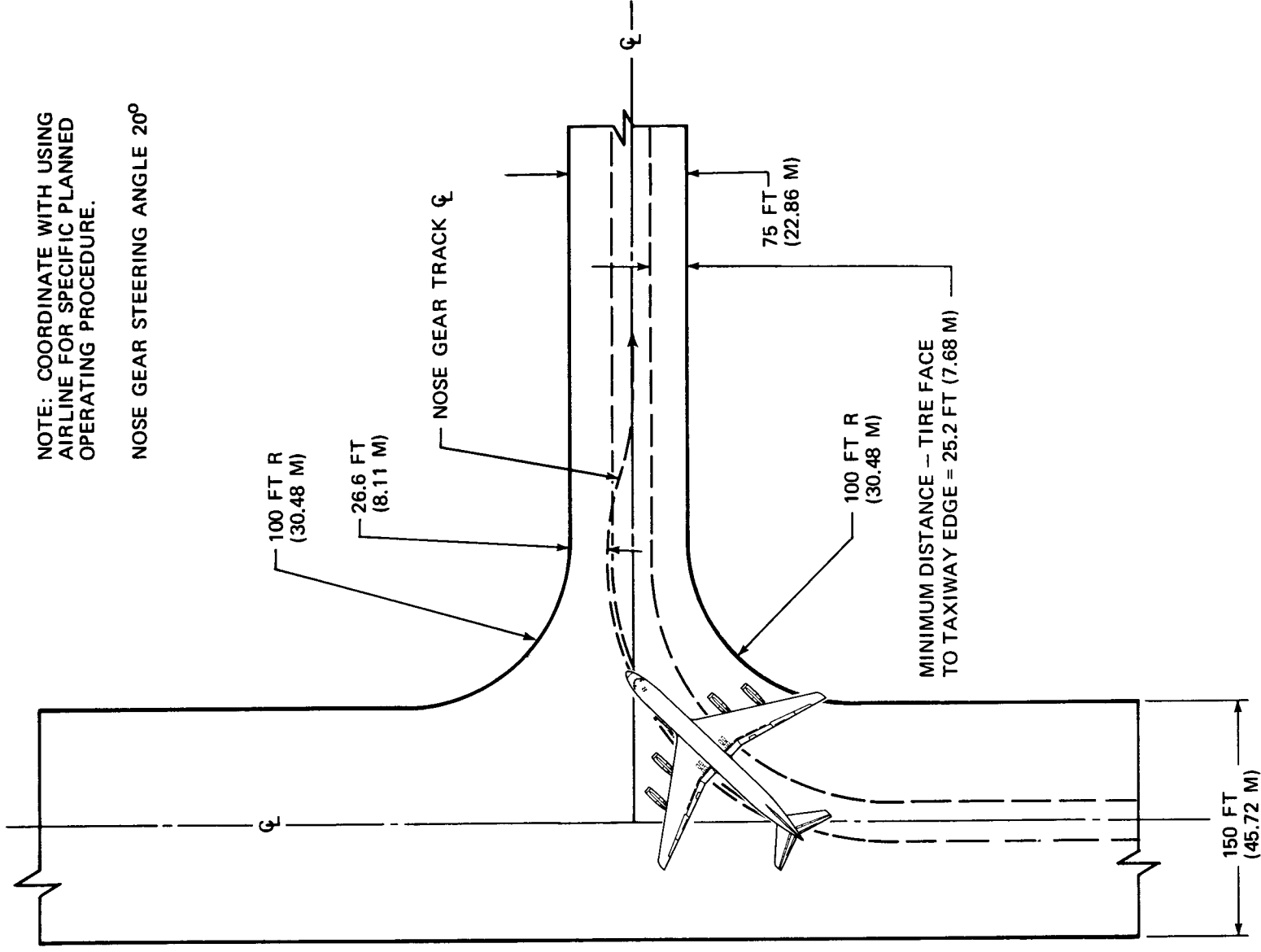

4.5.2 90° TURN – RUNWAY TO TAXIWAY MODEL DC-8-62, -62F, -72, -72F

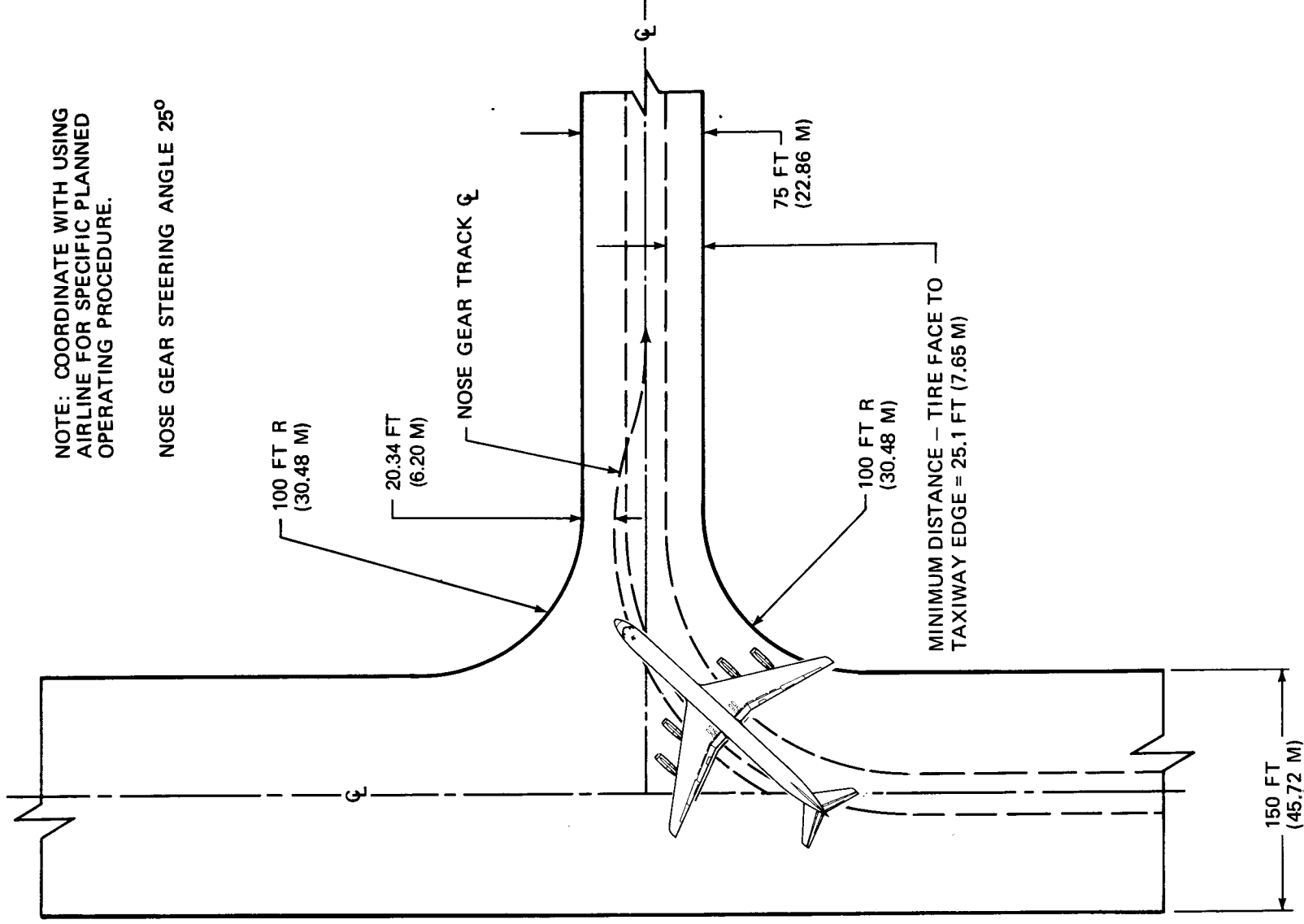

NOTE: COORDINATE WITH USING AIRLINE FOR SPECIFIC PLANNED OPERATING PROCEDURE.

NOSE GEAR STEERING ANGLE 25°

4.5.2 90° TURN — RUNWAY TO TAXIWAY
 MODEL DC-8-63, -63F, -73, -73F

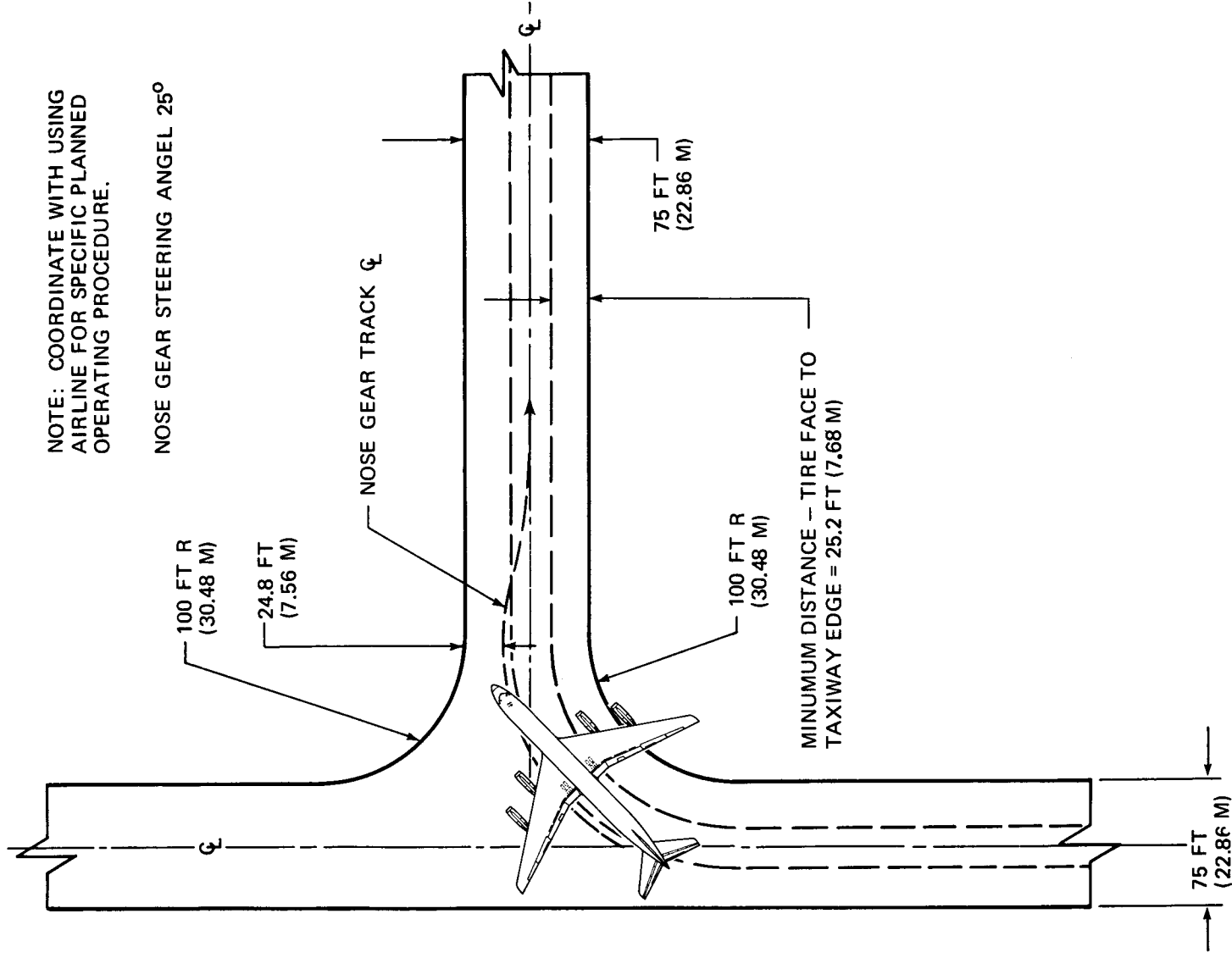

4.5 RUNWAY AND TAXIWAY TURN PATHS

4.5.3 90° TURN – TAXIWAY TO TAXIWAY

MODEL DC-8-43, -55, -55F

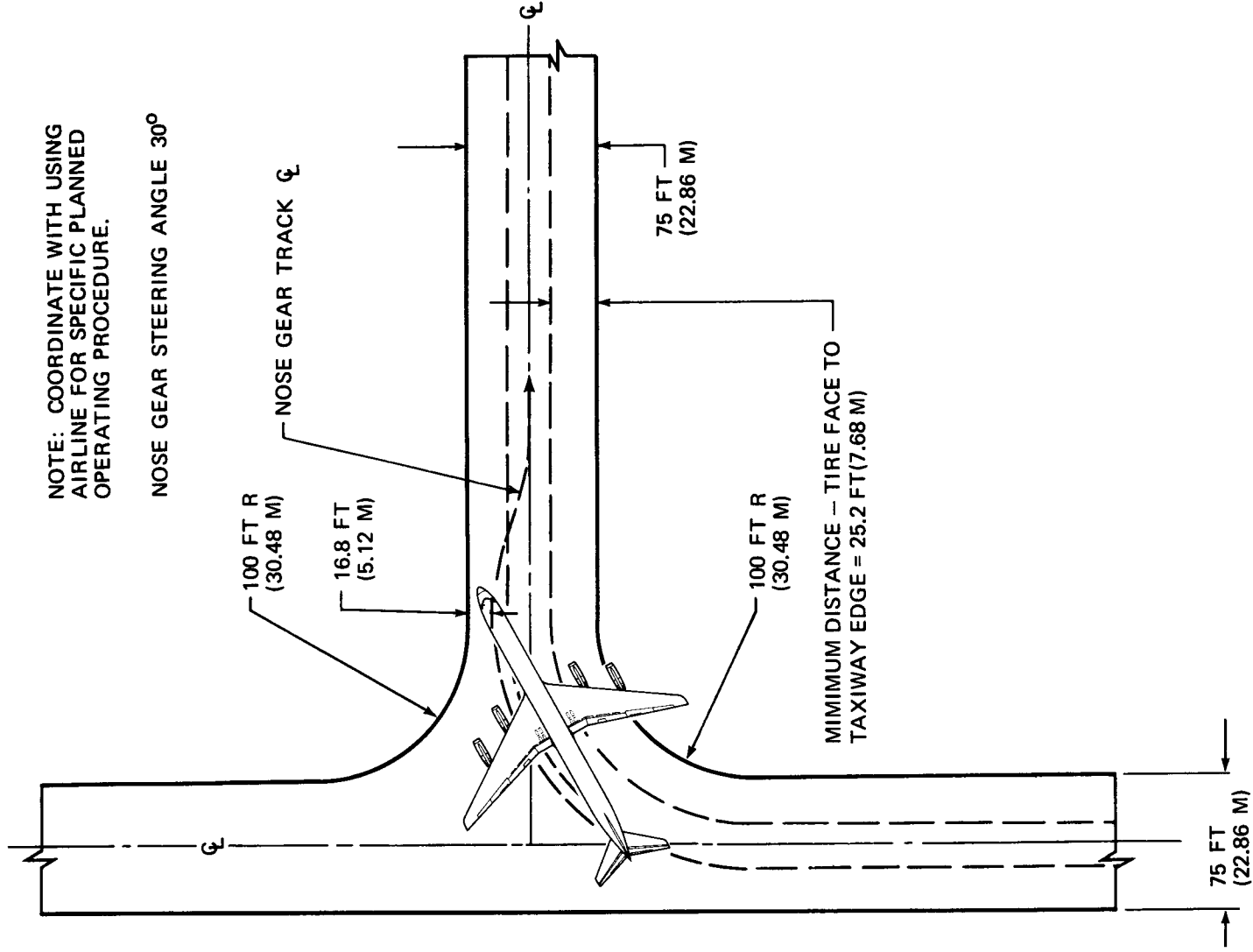

4.5.3 90° TURN — TAXIWAY TO TAXIWAY MODEL DC-8-61, -61F, -71, -71F

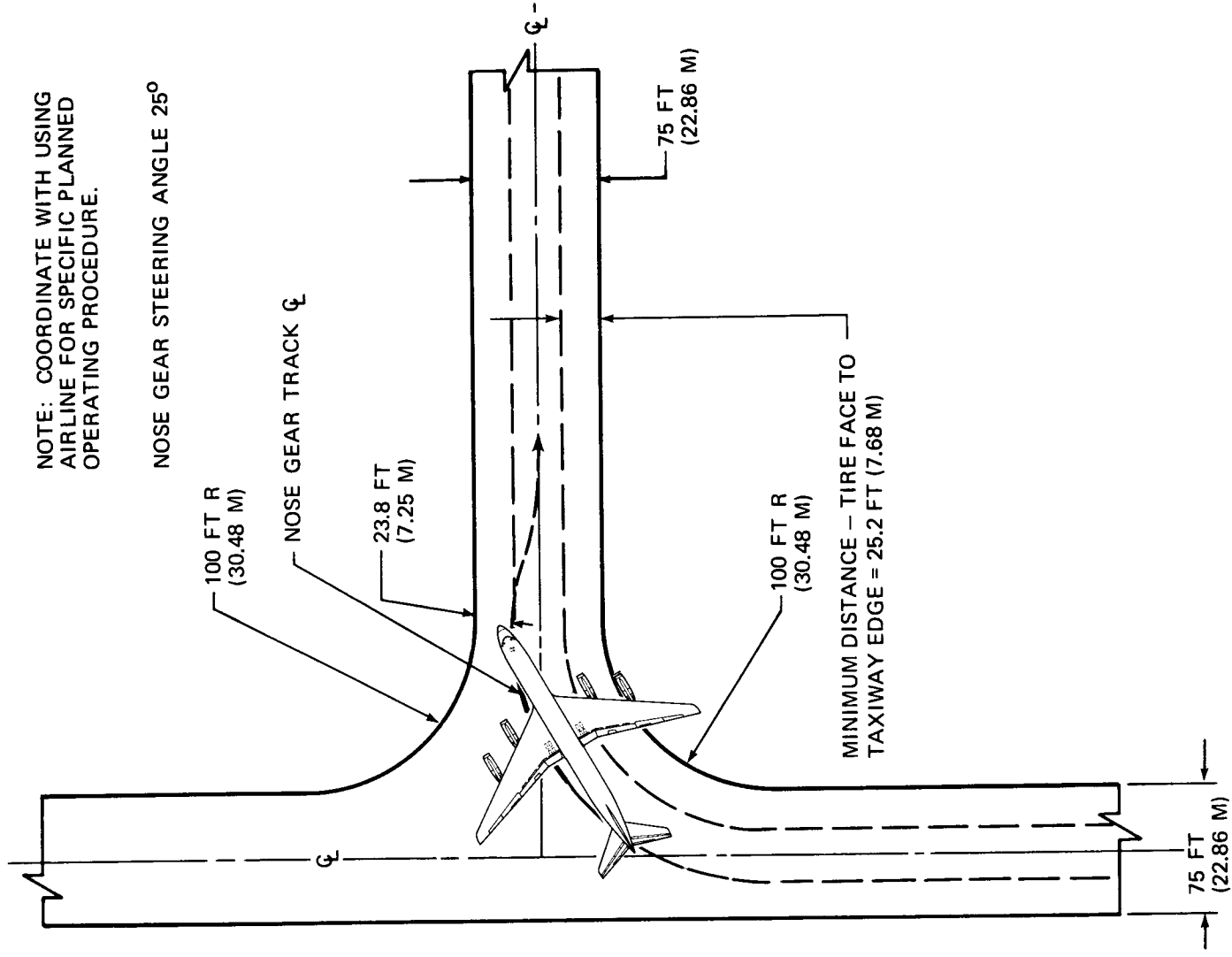

4.5.3 90° TURN — TAXIWAY TO TAXIWAY MODEL DC-8-62, -62F, -72, -72F

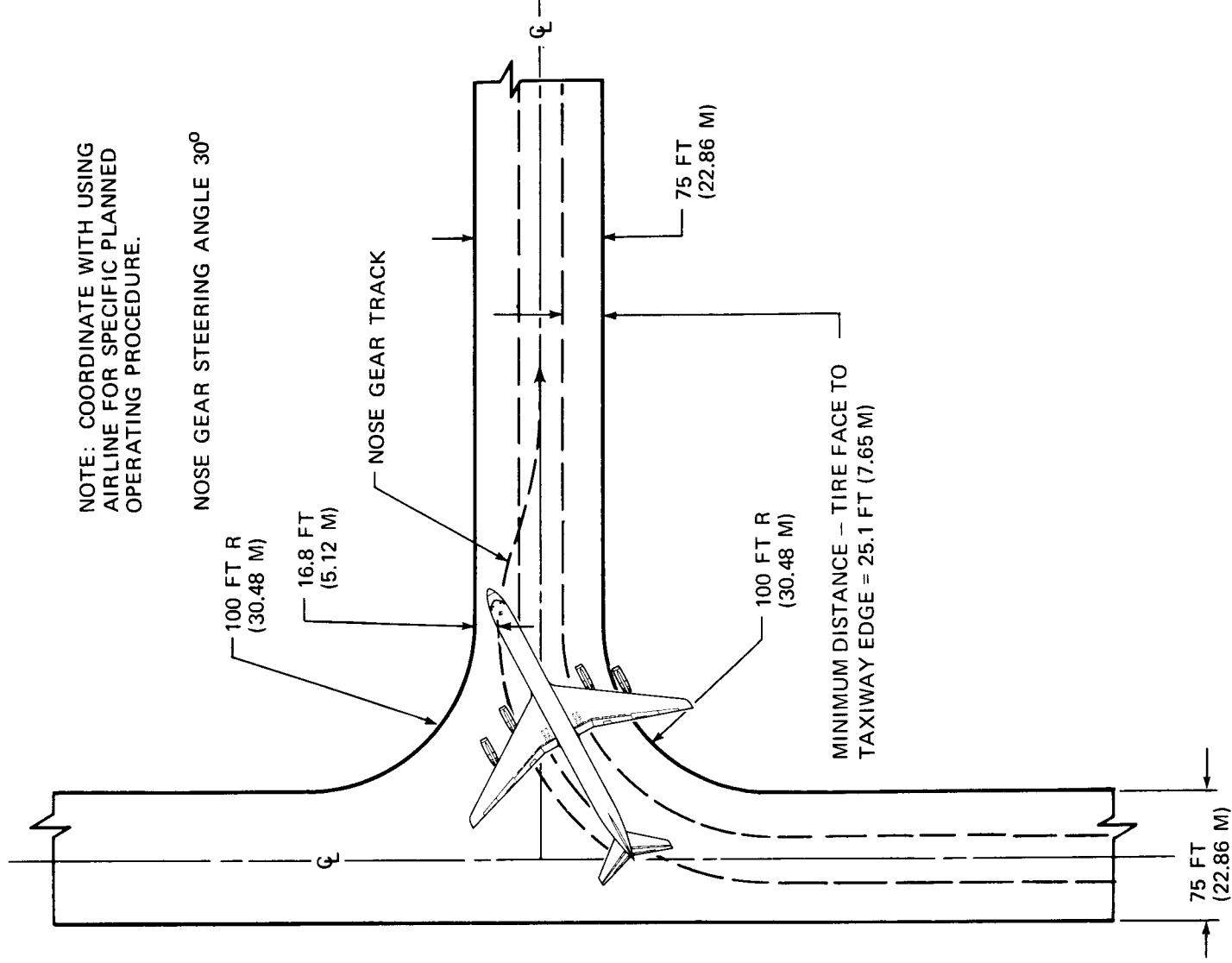

**4.5.3 90° TURN – TAXIWAY TO TAXIWAY
MODEL DC-8-63, -63F, -73, -73F**

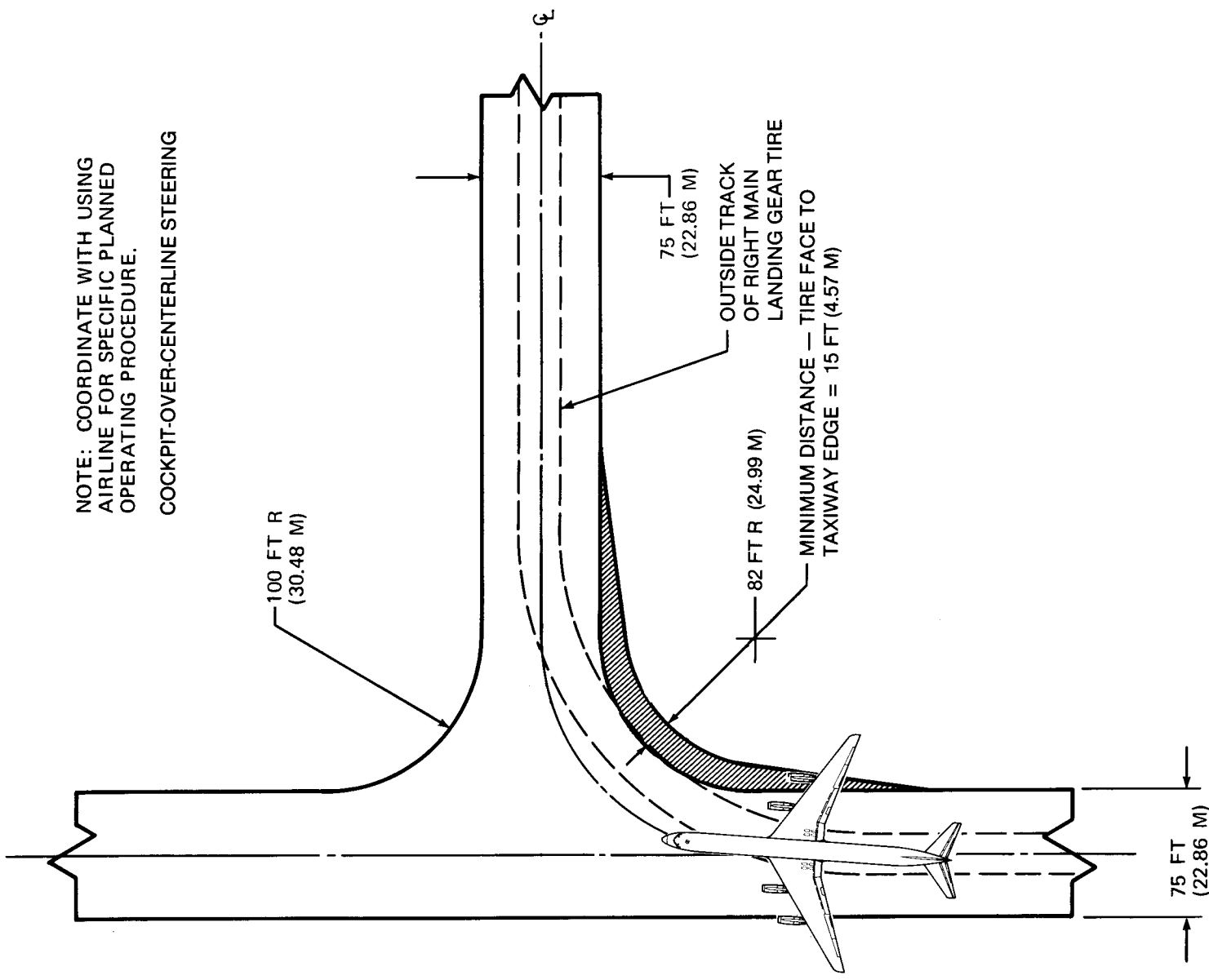

**4.5.3 90° TURN — TAXIWAY TO TAXIWAY
MODEL DC-8-61, -61F, -63, -63F, -71, -71F, -73, -73F**

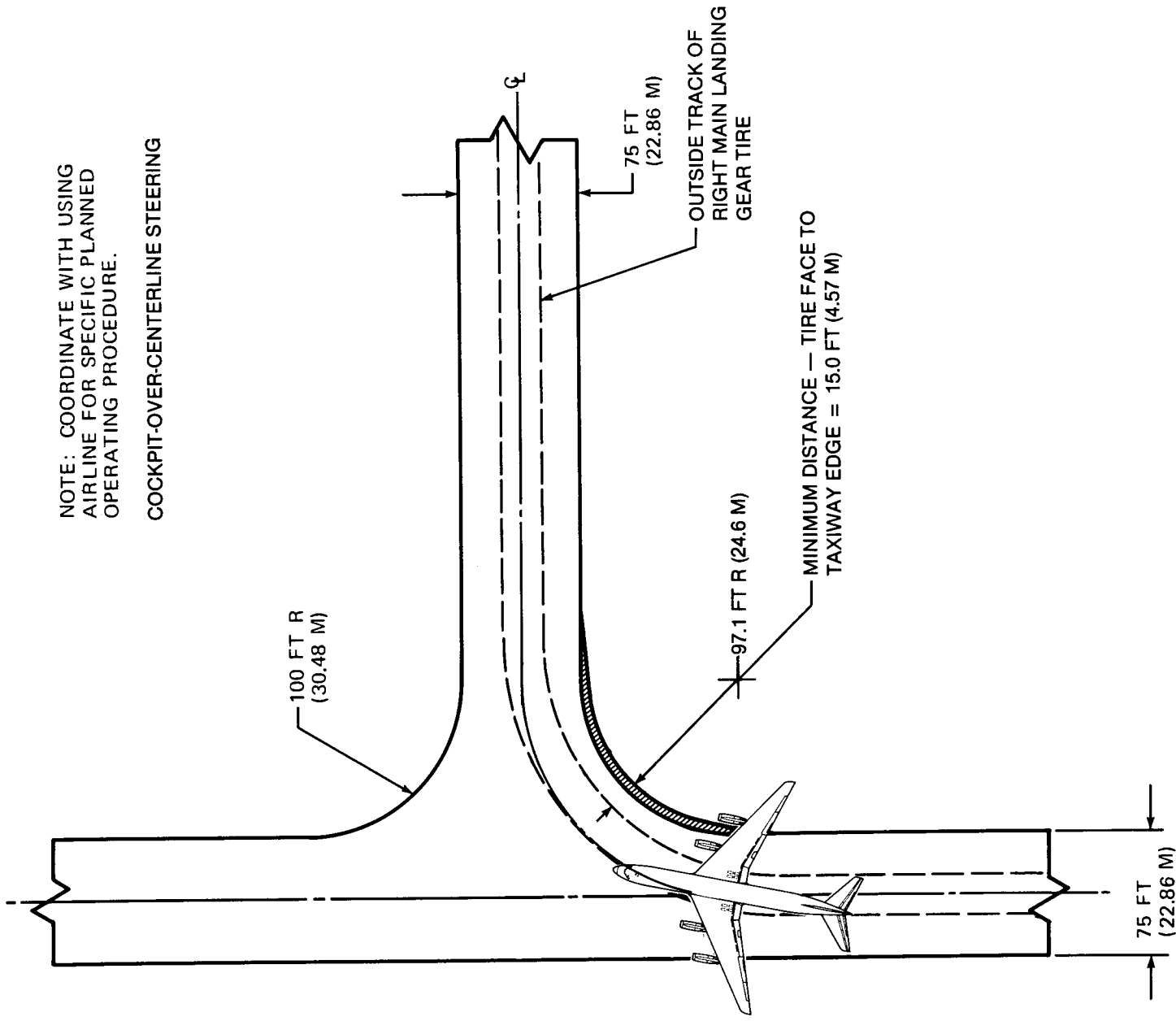

4.5.3 90° TURN — TAXIWAY TO TAXIWAY MODEL DC-8-43, -55, -55F

NOTE: COORDINATE WITH USING
AIRLINE FOR SPECIFIC PLANNED
OPERATING PROCEDURE.
COCKPIT-OVER-CENTERLINE STEERING

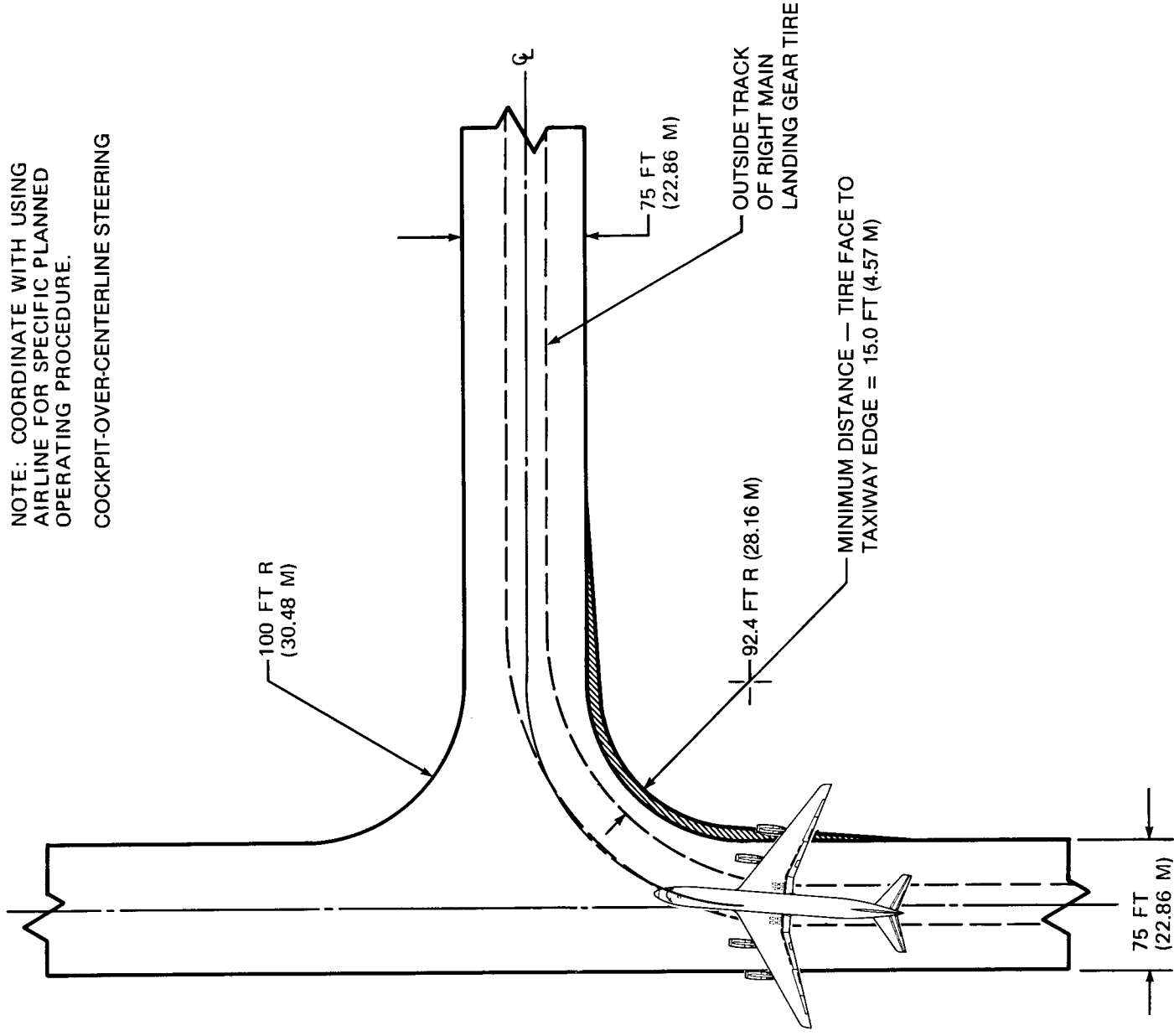

4.5.3 90° TURN — TAXIWAY TO TAXIWAY MODEL DC-8-62, -62F, -72, -72F

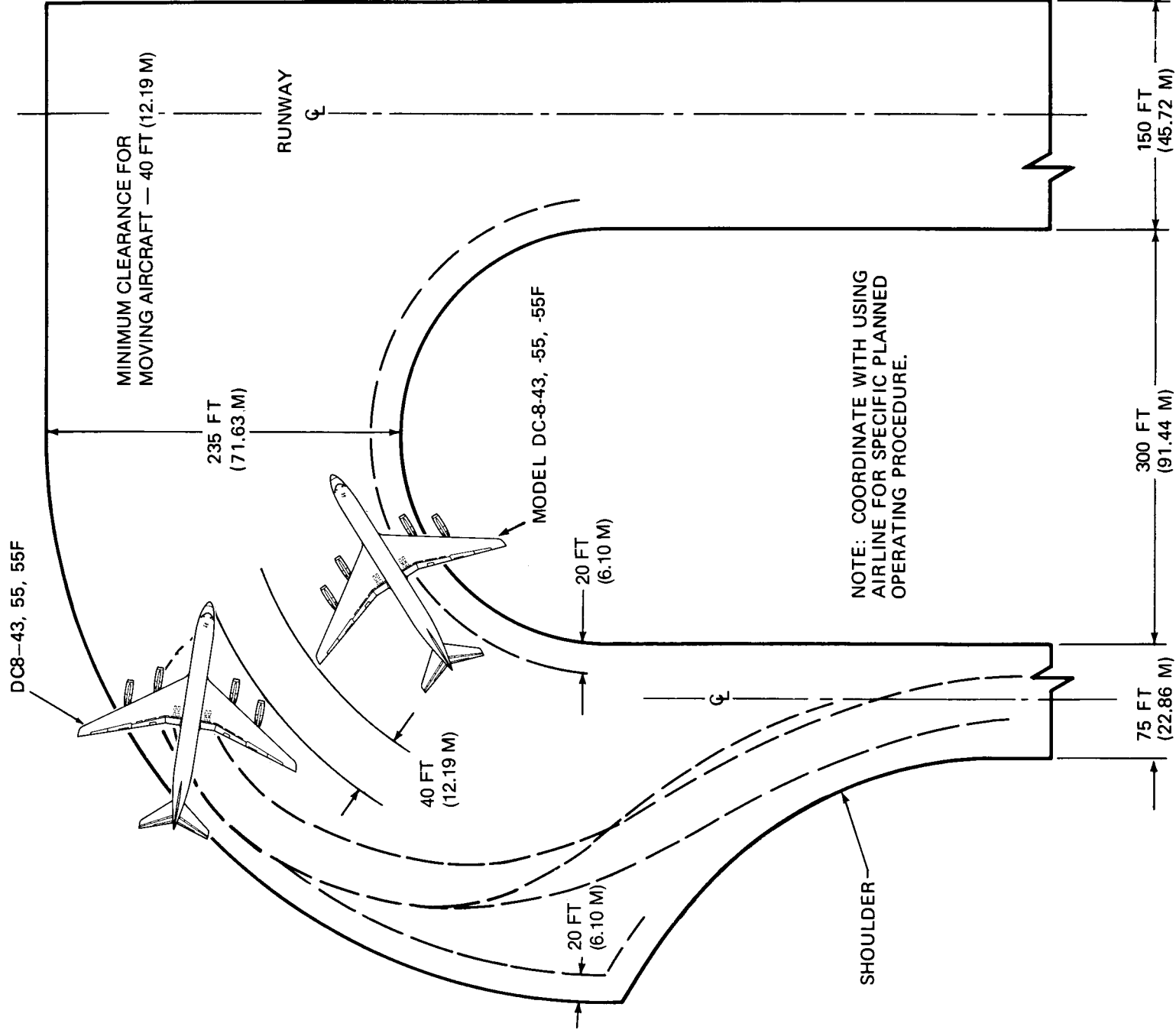

4.6. RUNWAY HOLDING APRON MODEL DC-8-43, -55, -55F

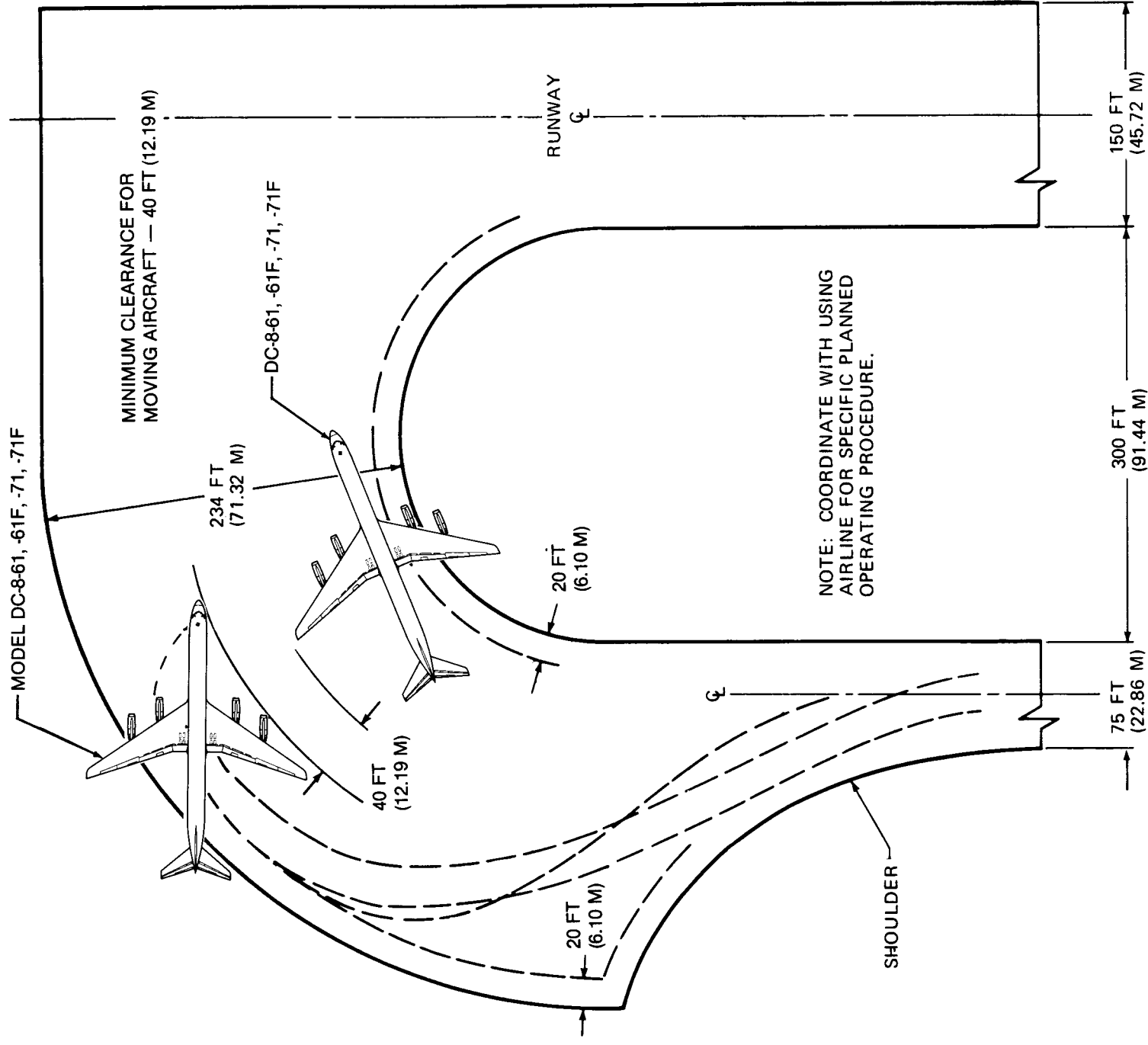

4.6. RUNWAY HOLDING APRON MODEL DC-8-61, -61F, -71, -71F

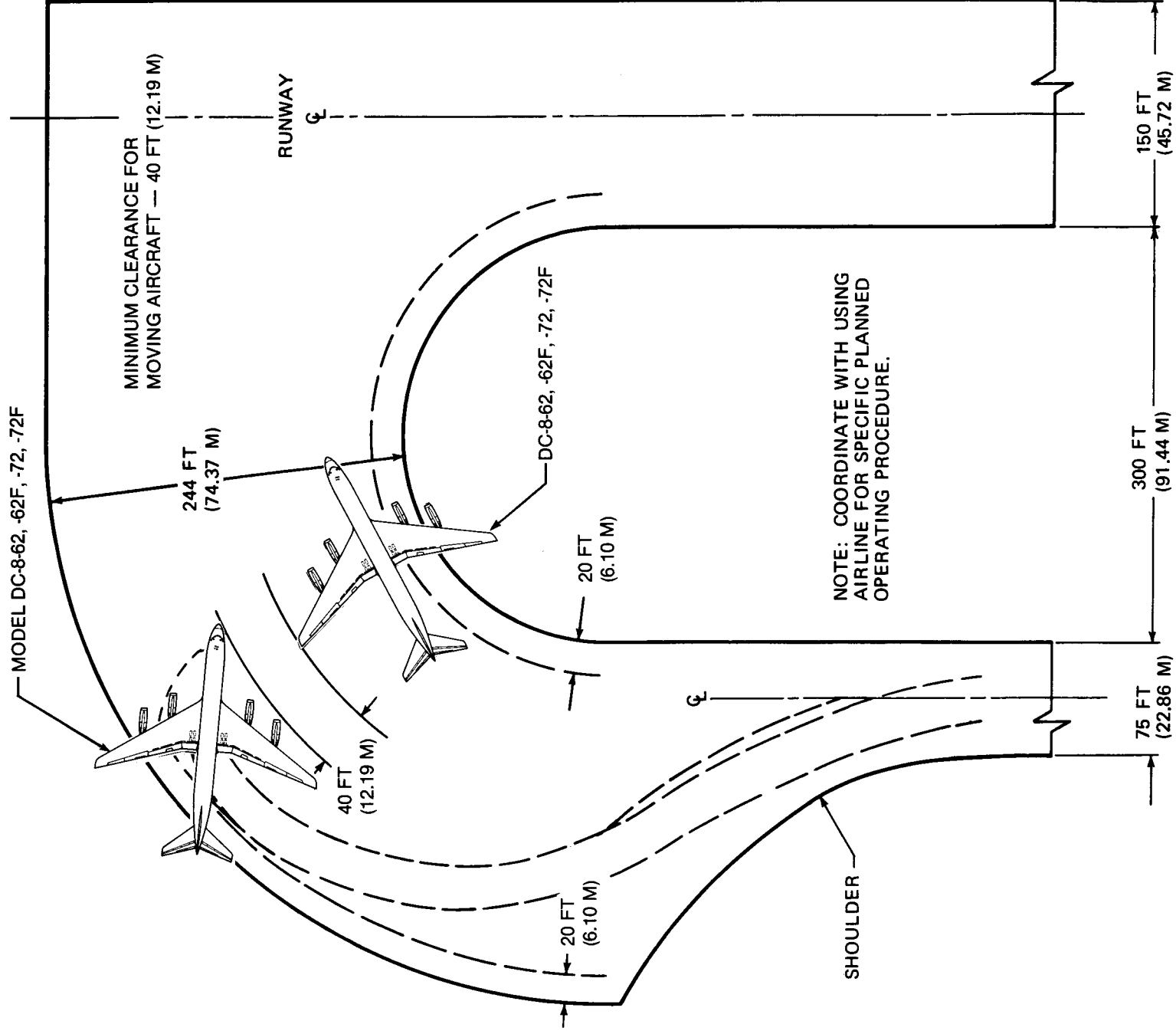

4.6. RUNWAY HOLDING APRON MODEL DC-8-62, -62F, -72, -72F

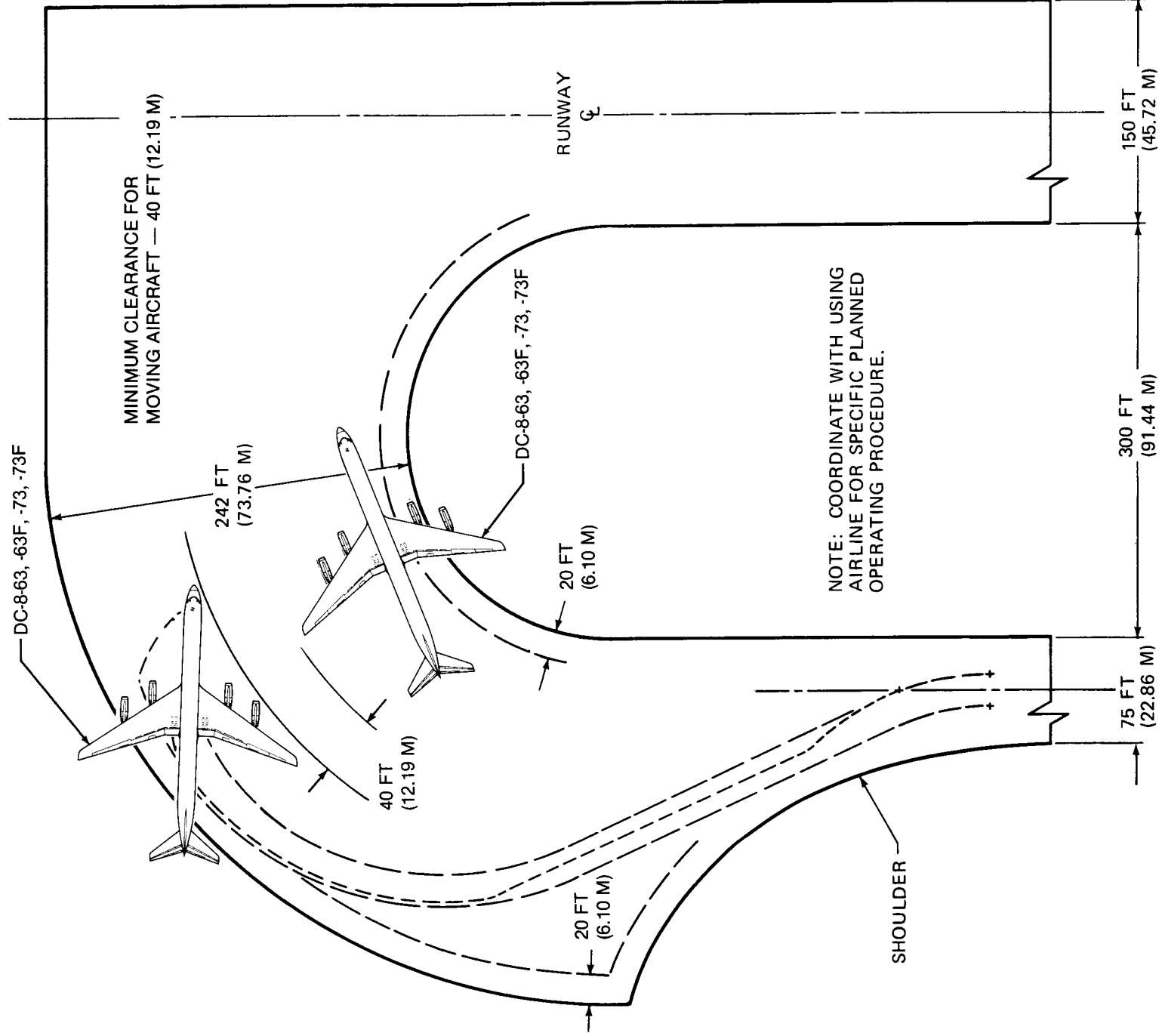

4.6. RUNWAY HOLDING APRON MODEL DC-8-63, -63F, -73, -73F

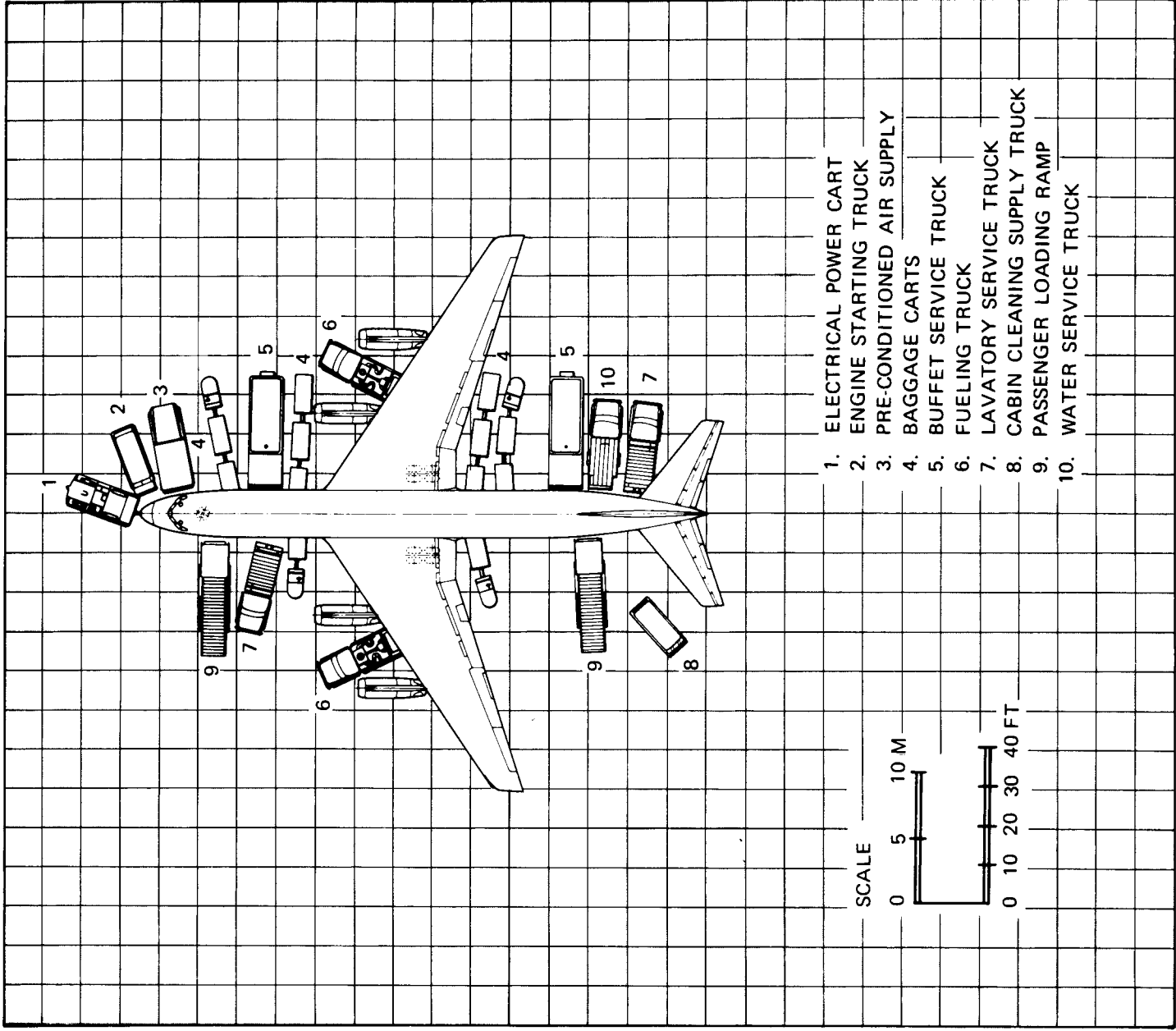

5.0 TERMINAL SERVICING
 5.1 AIRPLANE SERVICING ARRANGEMENT (TYPICAL)
 MODEL DC-8-43, -55

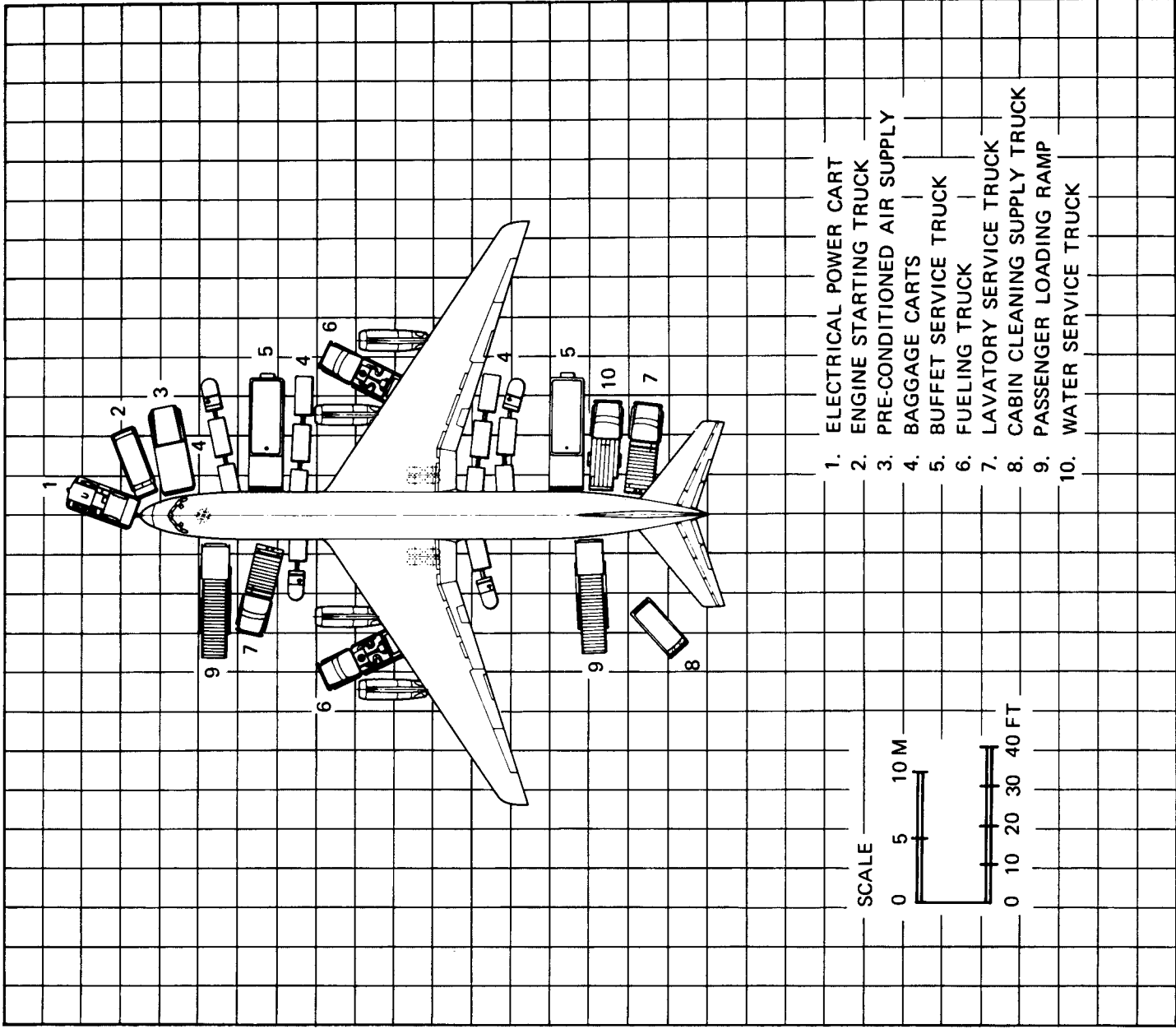

5.0 TERMINAL SERVICING
 5.1 AIRPLANE SERVICING ARRANGEMENT (TYPICAL)
 MODEL DC-8-62, -72

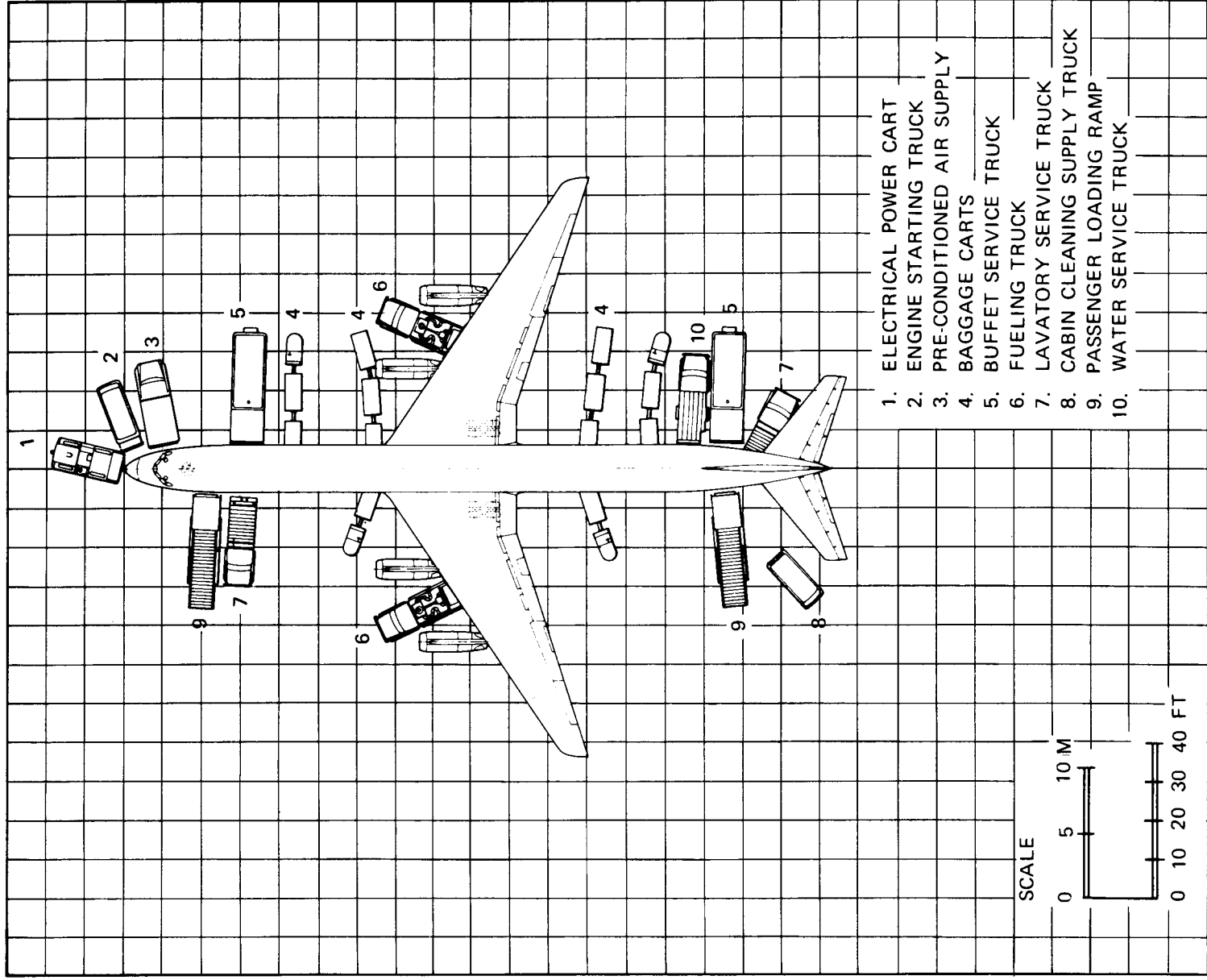

5.0 TERMINAL SERVICING
5.1 AIRPLANE SERVICING ARRANGEMENT (TYPICAL)
MODEL DC-8-61, -63, -71, -73

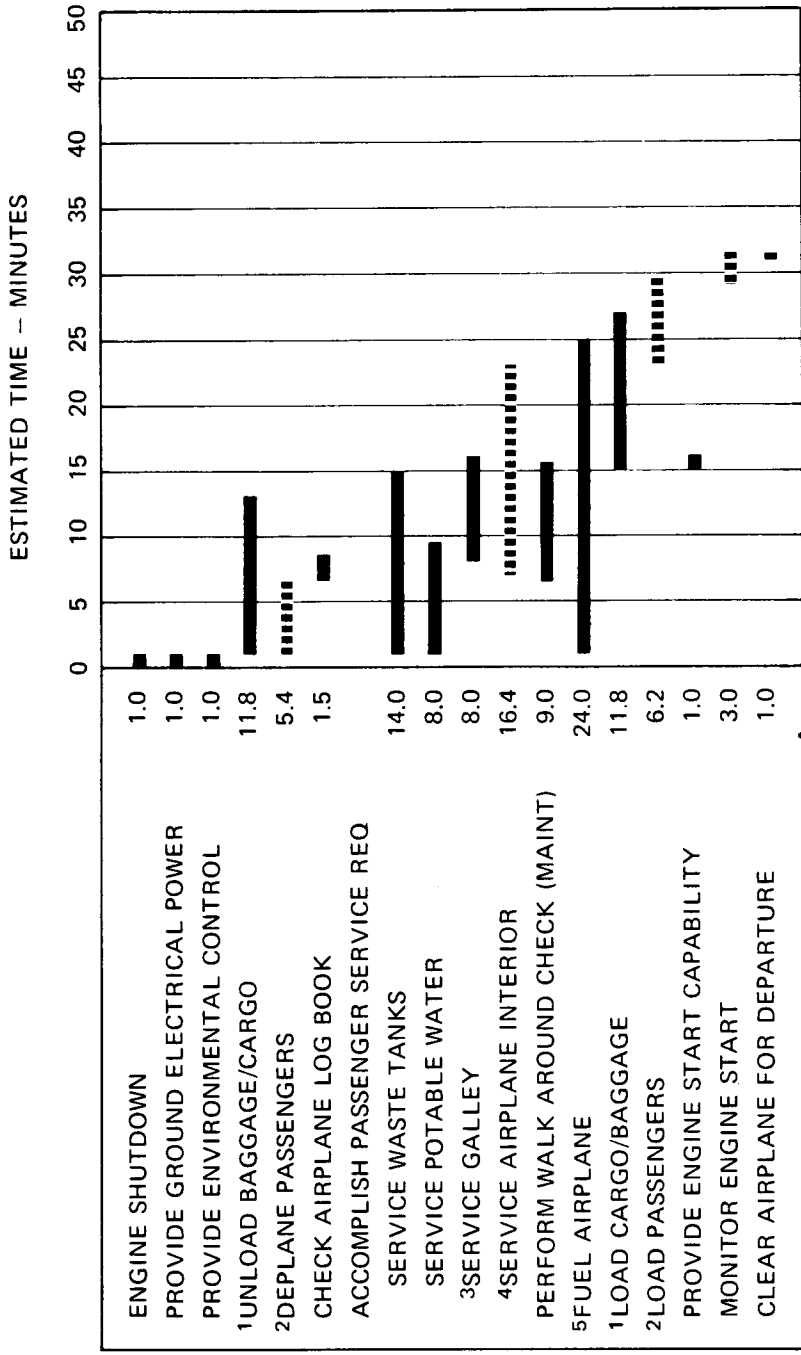

- 1 = 8-MAN CREW (BULK LOADING)
- 2 = 2-DOOR LOADING/UNLOADING
- 3 = 2-MAN CREW (MODULE SYSTEM)
- 4 = 14-MAN CREW
- 5 = 50 PSI PUMP OUTPUT
- 6 ■■■ = CRITICAL TIME PATH

NOTE:

THESE DATA ARE PROVIDED TO ILLUSTRATE THE GENERAL SCOPE AND TYPES OF TASKS INVOLVED IN TERMINAL OPERATIONS. VARYING AIRLINE PRACTICES AND OPERATING CIRCUMSTANCES THROUGHOUT THE WORLD WILL RESULT IN DIFFERENT SEQUENCES AND TIME INTERVALS TO ACCOMPLISH THE TASKS SHOWN.

BECAUSE OF THIS, GROUND OPERATIONS REQUIREMENTS SHOULD BE COORDINATED WITH THE USING AIRLINES PRIOR TO RAMP PLANNING.

5.2 TERMINAL OPERATIONS, TURNAROUND STATION MODEL DC-8-43

ESTIMATED TIME – MINUTES

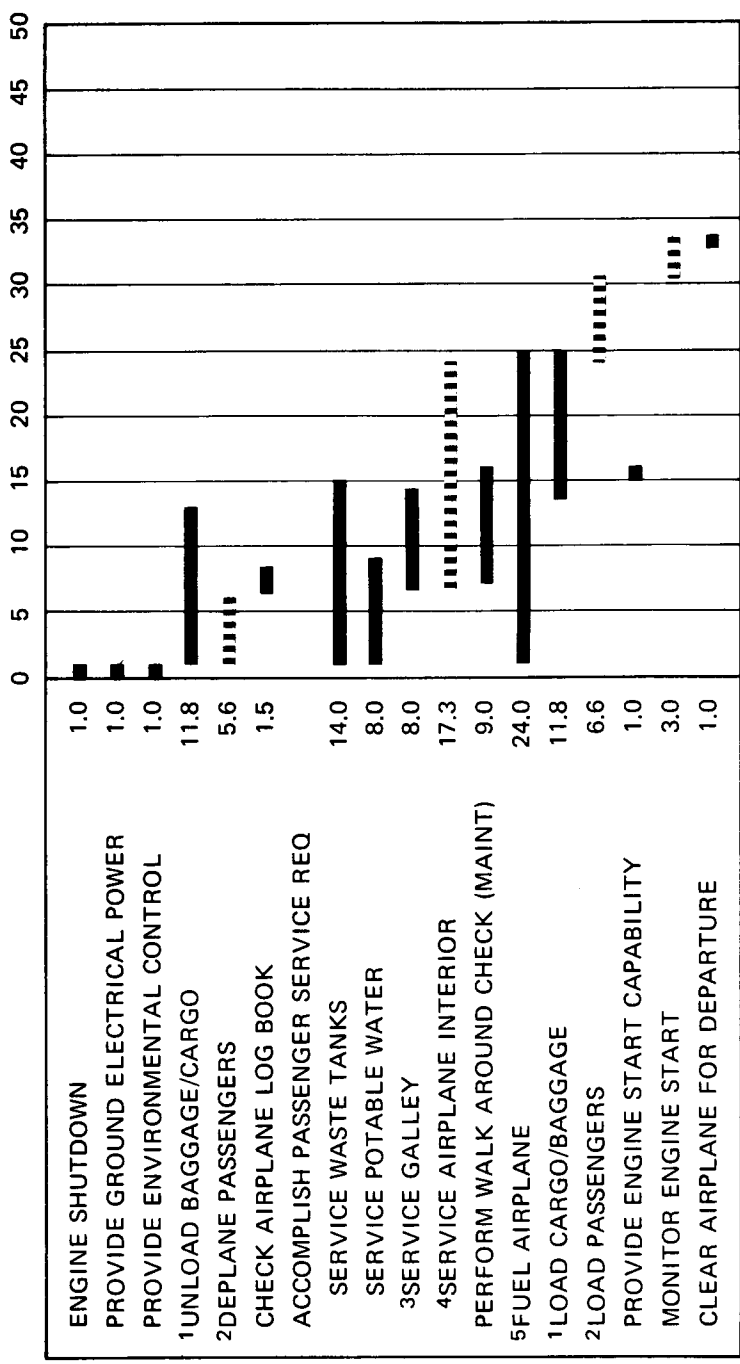

- 1 = 8-MAN CREW (BULK LOADING)
- 2 = 2-DOOR LOADING/UNLOADING
- 3 = 2-MAN CREW (MODULE SYSTEM)
- 4 = 14-MAN CREW
- 5 = 50 PSI PUMP OUTPUT
- 6 ■■■ = CRITICAL TIME PATH

NOTE:

THESE DATA ARE PROVIDED TO ILLUSTRATE THE GENERAL SCOPE AND TYPES OF TASKS INVOLVED IN TERMINAL OPERATIONS. VARYING AIRLINE PRACTICES AND OPERATING CIRCUMSTANCES THROUGHOUT THE WORLD WILL RESULT IN DIFFERENT SEQUENCES AND TIME INTERVALS TO ACCOMPLISH THE TASKS SHOWN.

BECAUSE OF THIS, GROUND OPERATIONS REQUIREMENTS SHOULD BE COORDINATED WITH THE USING AIRLINES PRIOR TO RAMP PLANNING.

5.2 TERMINAL OPERATIONS, TURNAROUND STATION MODEL DC-8-55

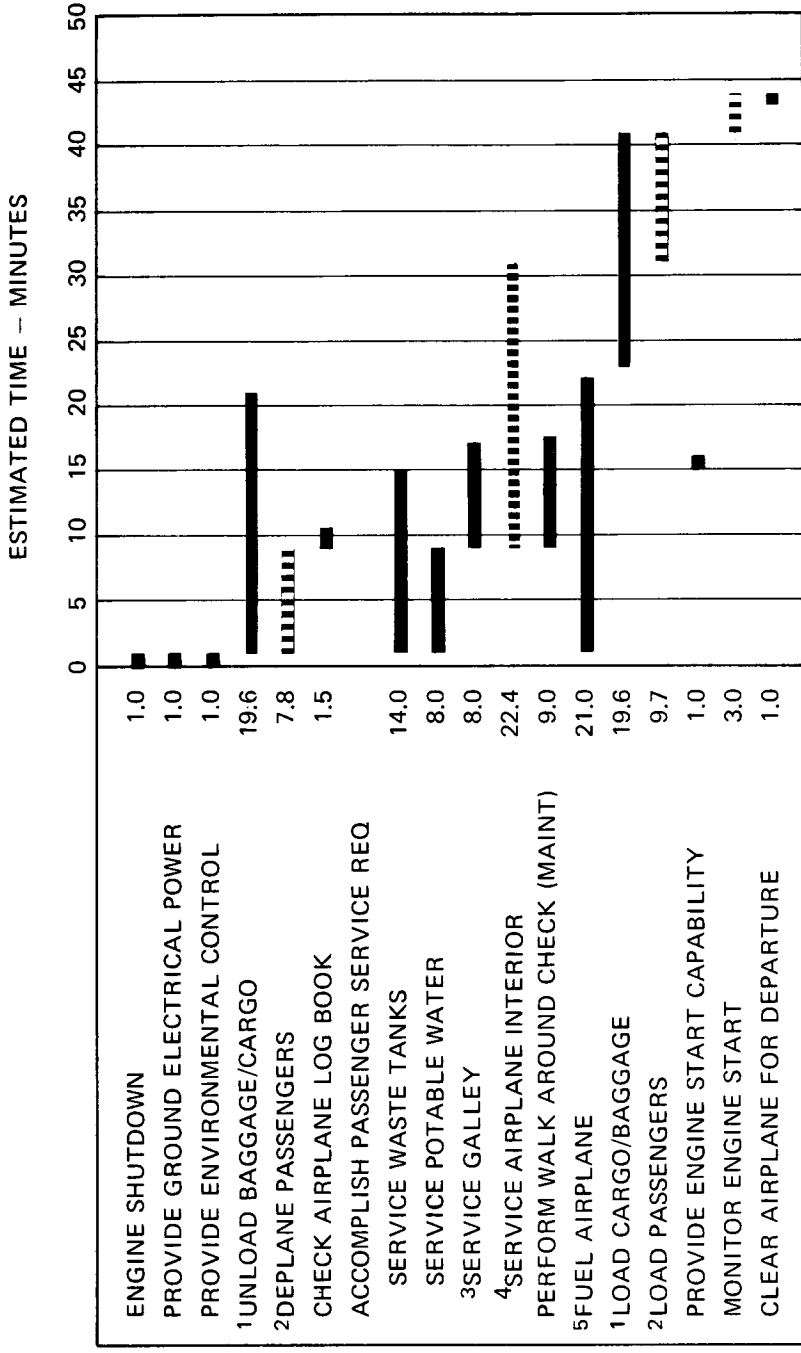

- 1 = 9-MAN CREW (BULK LOADING)
- 2 = 2-DOOR LOADING/UNLOADING
- 3 = 2-MAN CREW (MODULE SYSTEM)
- 4 = 14-MAN CREW
- 5 = 50 PSI PUMP OUTPUT
- 6 ■■■ = CRITICAL TIME PATH

NOTE:

THESE DATA ARE PROVIDED TO ILLUSTRATE THE GENERAL SCOPE AND TYPES OF TASKS INVOLVED IN TERMINAL OPERATIONS. VARYING AIRLINE PRACTICES AND OPERATING CIRCUMSTANCES THROUGHOUT THE WORLD WILL RESULT IN DIFFERENT SEQUENCES AND TIME INTERVALS TO ACCOMPLISH THE TASKS SHOWN.

BECAUSE OF THIS, GROUND OPERATIONS REQUIREMENTS SHOULD BE COORDINATED WITH THE USING AIRLINES PRIOR TO RAMP PLANNING.

5.2 TERMINAL OPERATIONS, TURNAROUND STATION MODEL DC-8-61, -71

ESTIMATED TIME – MINUTES

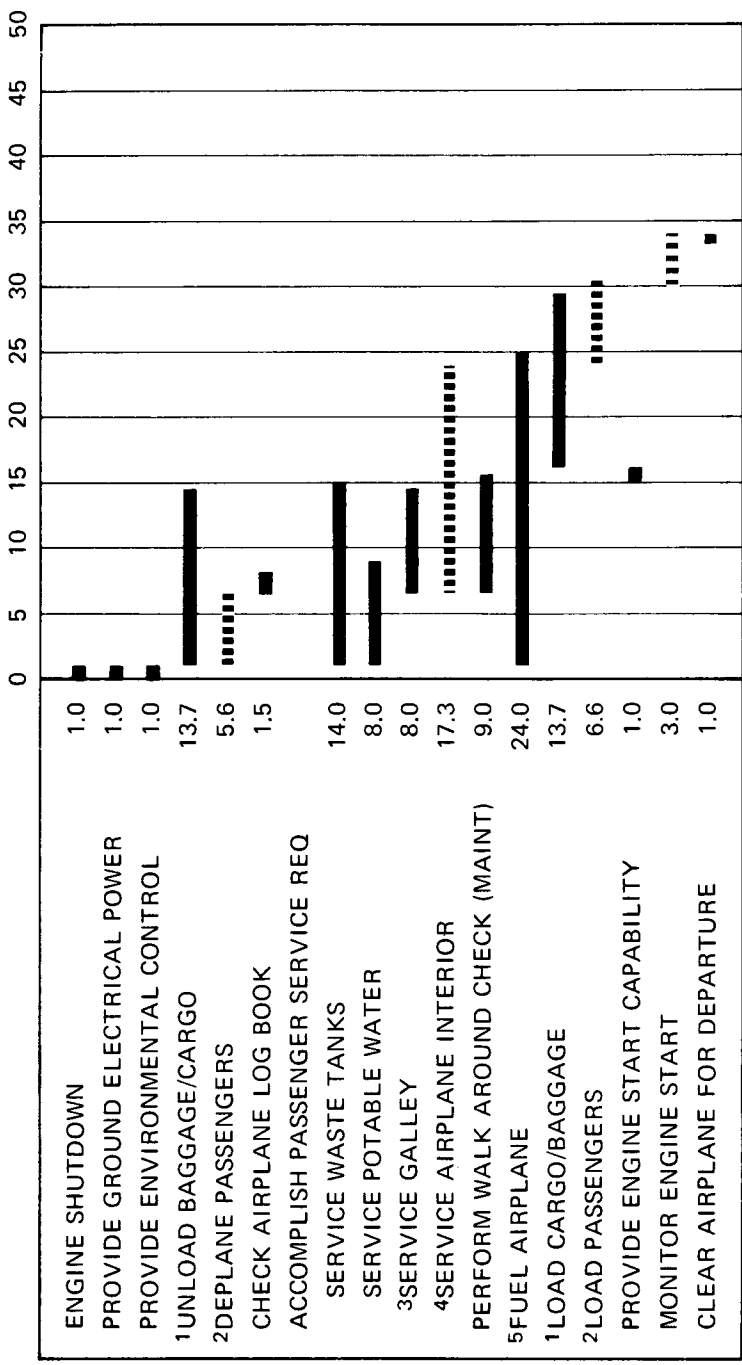

- 1 = 8-MAN CREW (BULK LOADING)
- 2 = 2-DOOR LOAD/UNLOAD
- 3 = 2-MAN CREW (MODULE SYSTEM)
- 4 = 14-MAN CREW
- 5 = 50 PSI PUMP OUTPUT
- 6 ■■■ = CRITICAL TIME PATH

NOTE:

THESE DATA ARE PROVIDED TO ILLUSTRATE THE GENERAL SCOPE AND TYPES OF TASKS INVOLVED IN TERMINAL OPERATIONS. VARYING AIRLINE PRACTICES AND OPERATING CIRCUMSTANCES THROUGHOUT THE WORLD WILL RESULT IN DIFFERENT SEQUENCES AND TIME INTERVALS TO ACCOMPLISH THE TASKS SHOWN.

BECAUSE OF THIS, GROUND OPERATIONS REQUIREMENTS SHOULD BE COORDINATED WITH THE USING AIRLINES PRIOR TO RAMP PLANNING.

5.2 TERMINAL OPERATIONS, TURNAROUND STATION MODEL DC-8-62, -72

ESTIMATED TIME – MINUTES

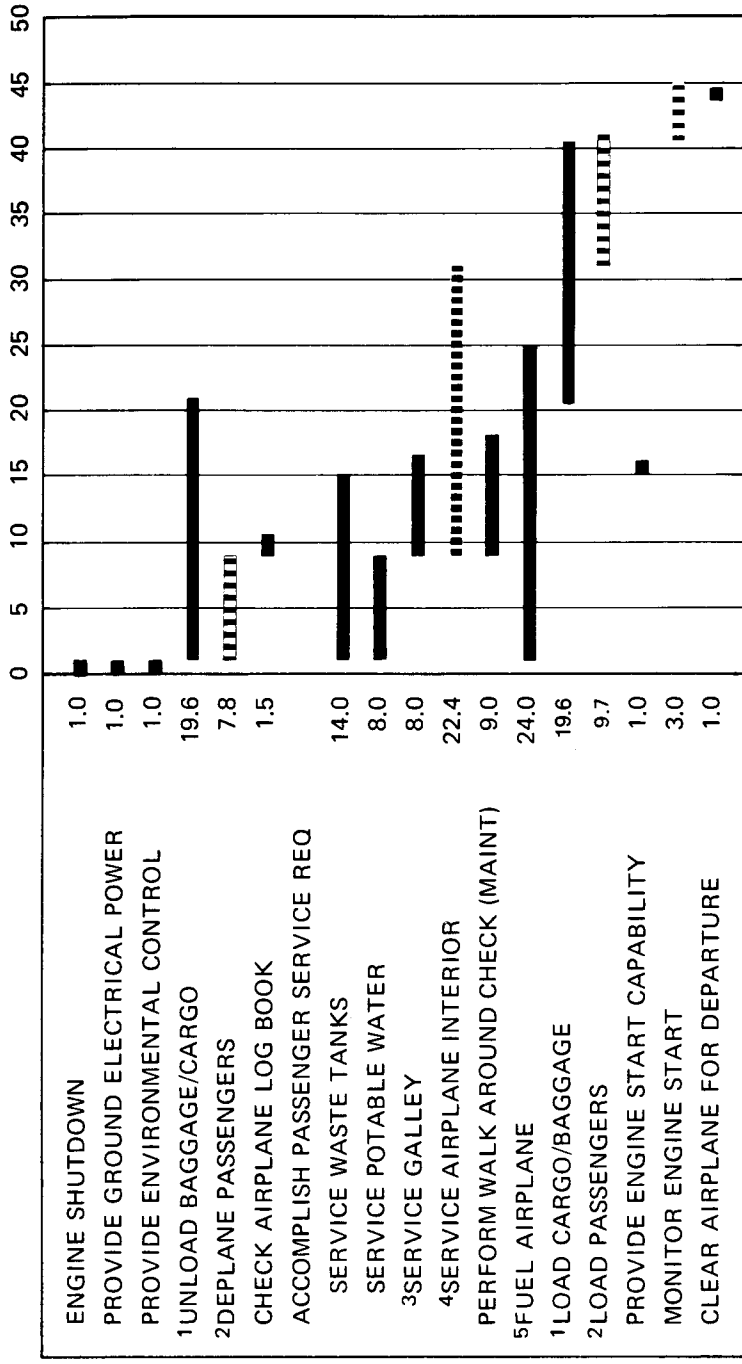

- 1 = 9-MAN CREW (BULK LOADING)
- 2 = 2-DOOR LOADING/UNLOADING
- 3 = 2-MAN CREW (MODULE SYSTEM)
- 4 = 14-MAN CREW
- 5 = 50 PSI PUMP OUTPUT
- 6 ■■■ = CRITICAL TIME PATH

NOTE:

THESE DATA ARE PROVIDED TO ILLUSTRATE THE GENERAL SCOPE AND TYPES OF TASKS INVOLVED IN TERMINAL OPERATIONS. VARYING AIRLINE PRACTICES AND OPERATING CIRCUMSTANCES THROUGHOUT THE WORLD WILL RESULT IN DIFFERENT SEQUENCES AND TIME INTERVALS TO ACCOMPLISH THE TASKS SHOWN.

BECAUSE OF THIS, GROUND OPERATIONS REQUIREMENTS SHOULD BE COORDINATED WITH THE USING AIRLINES PRIOR TO RAMP PLANNING.

5.2 TERMINAL OPERATIONS, TURNAROUND STATION MODEL DC-8-63, -73

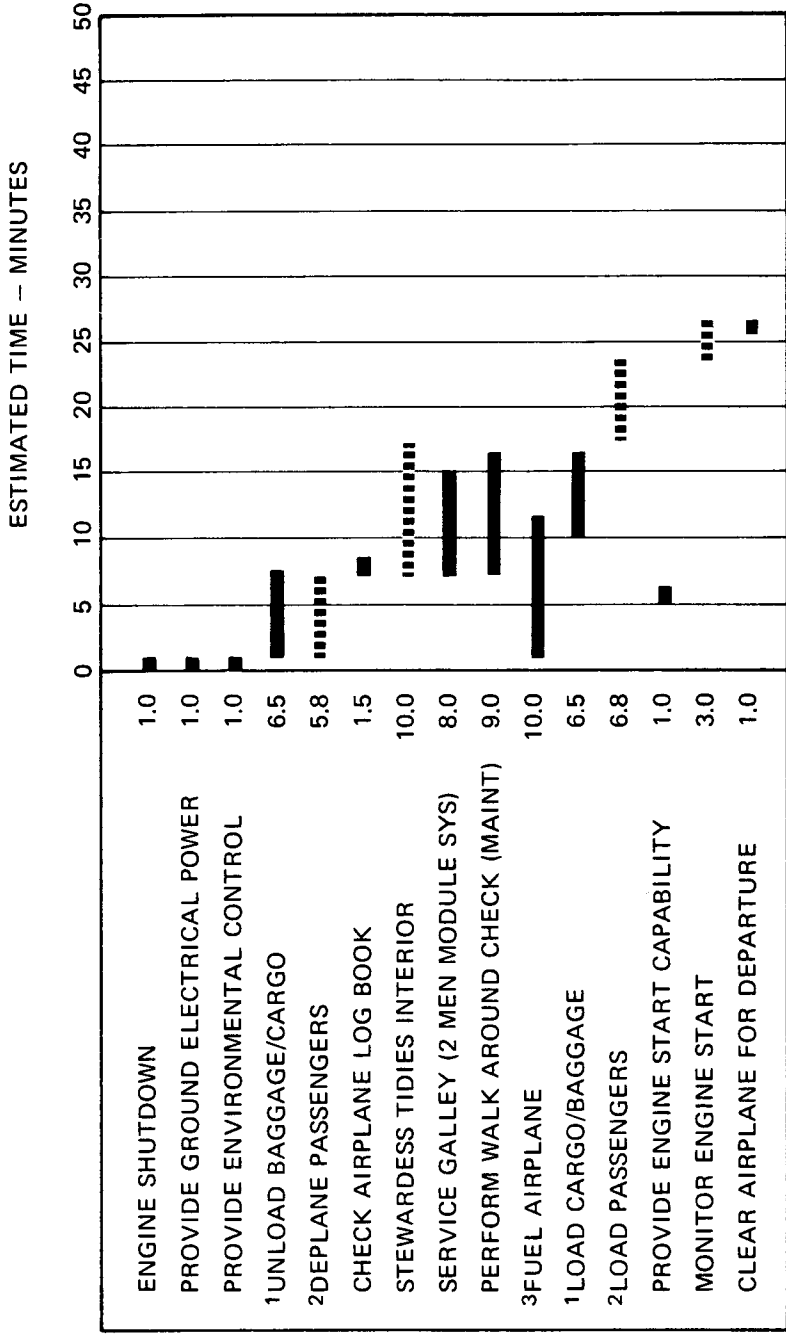

- 1 = 8-MAN CREW (BULK LOADING)
- 2 = SINGLE DOOR LOADING/UNLOADING
- 3 = 50 PSI PUMP OUTPUT
- 4 ■■■ = CRITICAL TIME PATH

NOTE:

THESE DATA ARE PROVIDED TO ILLUSTRATE THE GENERAL SCOPE AND TYPES OF TASKS INVOLVED IN TERMINAL OPERATIONS. VARYING AIRLINE PRACTICES AND OPERATING CIRCUMSTANCES THROUGHOUT THE WORLD WILL RESULT IN DIFFERENT SEQUENCES AND TIME INTERVALS TO ACCOMPLISH THE TASKS SHOWN.

BECAUSE OF THIS, GROUND OPERATIONS REQUIREMENTS SHOULD BE COORDINATED WITH THE USING AIRLINES PRIOR TO RAMP PLANNING.

5.3 TERMINAL OPERATIONS, EN ROUTE STATION MODEL DC-8-43, -55

ESTIMATED TIME -- MINUTES

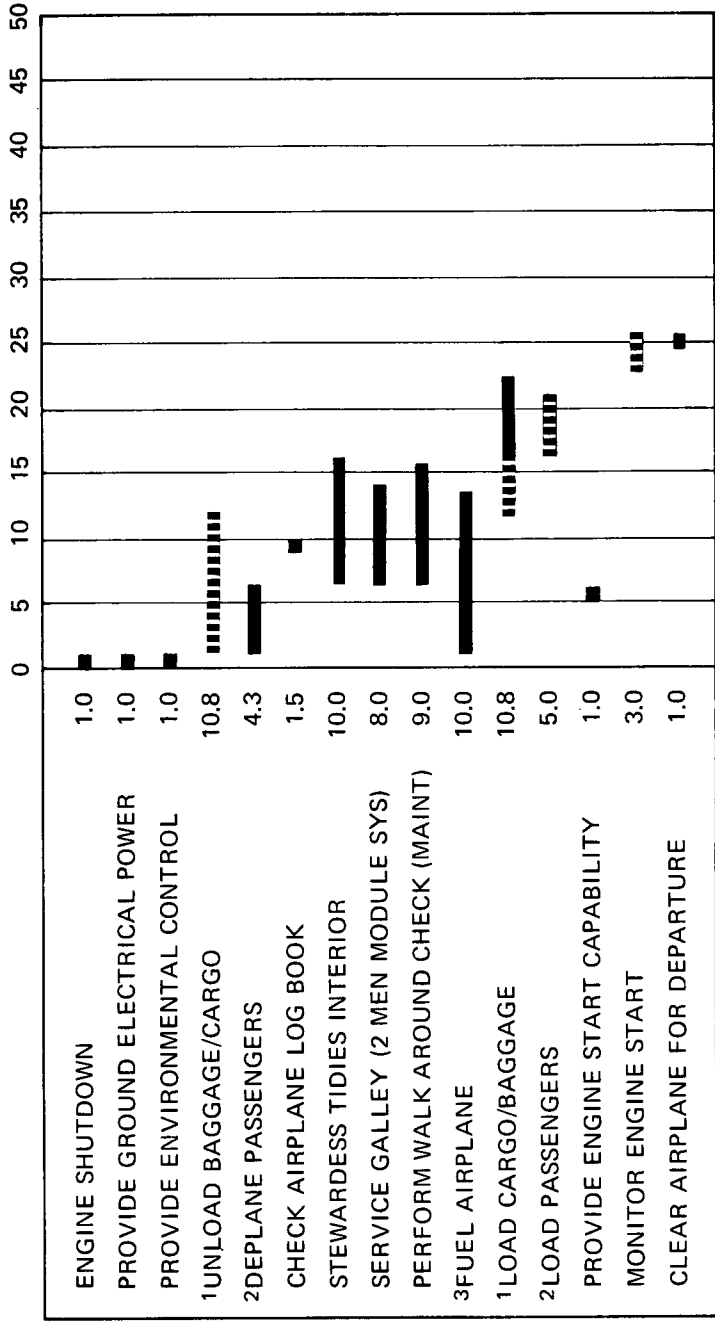

- 1 = 9-MAN CREW (BULK LOADING)
- 2 = 2-DOOR LOADING/UNLOADING
- 3 = 50 PSI PUMP OUTPUT
- 4 ■■■ = CRITICAL TIME PATH

NOTE:

THESE DATA ARE PROVIDED TO ILLUSTRATE THE GENERAL SCOPE AND TYPES OF TASKS INVOLVED IN TERMINAL OPERATIONS. VARYING AIRLINE PRACTICES AND OPERATING CIRCUMSTANCES THROUGHOUT THE WORLD WILL RESULT IN DIFFERENT SEQUENCES AND TIME INTERVALS TO ACCOMPLISH THE TASKS SHOWN.

BECAUSE OF THIS, GROUND OPERATIONS REQUIREMENTS SHOULD BE COORDINATED WITH THE USING AIRLINES PRIOR TO RAMP PLANNING.

5.3 TERMINAL OPERATIONS, EN ROUTE STATION MODEL DC-8-61, -63, -71, -73

ESTIMATED TIME – MINUTES

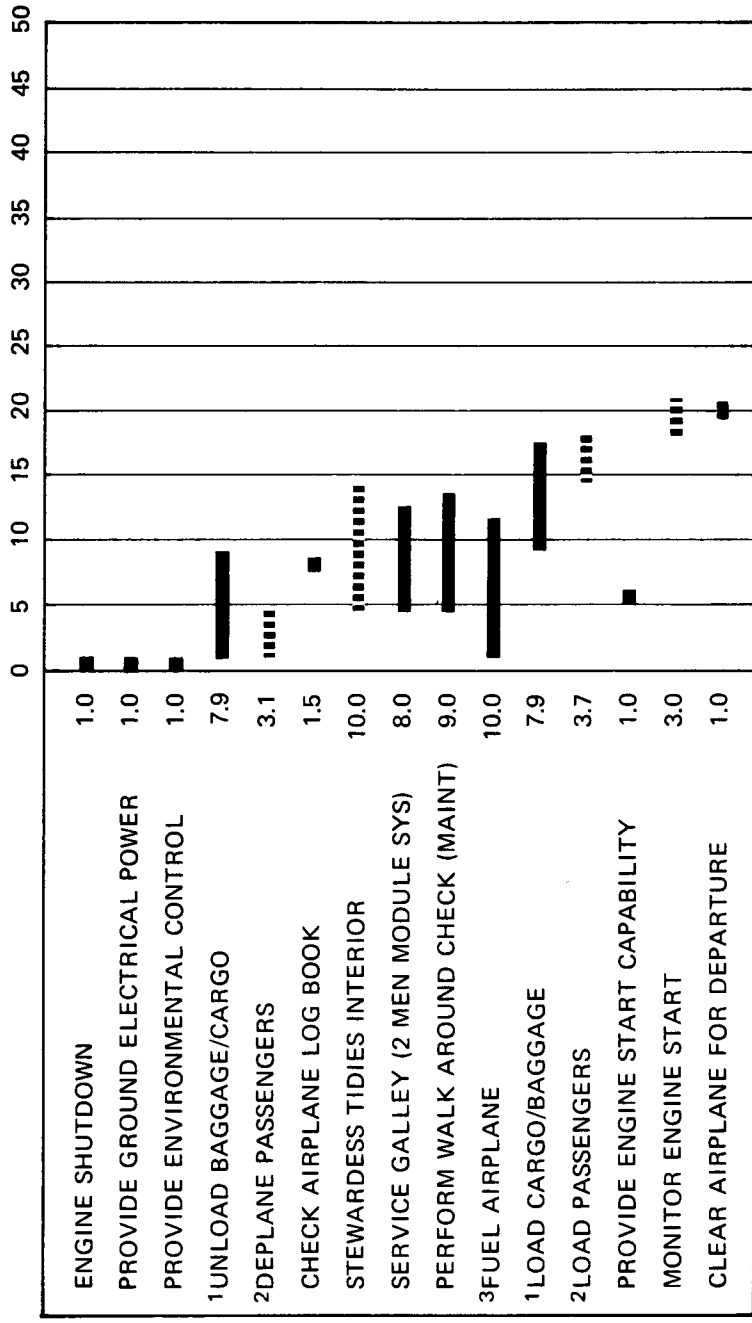

1 = 8-MAN CREW (BULK LOADING)

2 = 2-DOOR LOADING/UNLOADING

3 = 50 PSI PUMP OUTPUT

4 ■■■■ = CRITICAL TIME PATH

NOTE:

THESE DATA ARE PROVIDED TO ILLUSTRATE THE GENERAL SCOPE AND TYPES OF TASKS INVOLVED IN TERMINAL OPERATIONS. VARYING AIRLINE PRACTICES AND OPERATING CIRCUMSTANCES THROUGHOUT THE WORLD WILL RESULT IN DIFFERENT SEQUENCES AND TIME INTERVALS TO ACCOMPLISH THE TASKS SHOWN.

BECAUSE OF THIS, GROUND OPERATIONS REQUIREMENTS SHOULD BE COORDINATED WITH THE USING AIRLINES PRIOR TO RAMP PLANNING.

5.3 TERMINAL OPERATIONS, EN ROUTE STATION MODEL DC-8-62, -72

ITEM NO.	DESCRIPTION
1	GROUND HYDRAULIC POWER SUPPLY AND PRESSURE FILL PORT
2	OVERWING GRAVITY REFUELING POINTS
3	PRESSURE REFUELING POINTS
4	MOORING POINT
5	WING JACK POINT
6	AUXILIARY PUMP ACCUMULATOR
7	BRAKE ACCUMULATORS (3)
8	MAIN SYSTEM ACCUMULATOR
9	*PASSENGER OXYGEN BOTTLES
10	EMPENNAGE ACCUMULATOR
11	*AFT WASTE DISPOSAL SERVICE PANEL
12	*AFT POTABLE WATER SERVICE PANEL
13	STANDBY RUDDER ACCUMULATOR
14	SPOILER ACCUMULATOR
15	PNEUMATIC ENGINE START CONNECTION
16	CONSTANT SPEED DRIVE (TYPICAL EACH ENGINE)
17	ENGINE OIL (TYPICAL EACH ENGINE)
18	NOSE JACK POINT
19	PRE-CONDITIONED AIR
20	ALT NOSE STEERING ACCUMULATOR
21	GROUND ELECTRIC POWER
22	PNEUMATIC POWER
23.	FORWARD POTABLE WATER SERVICE PANEL
24	FORWARD WASTE DISPOSAL SERVICE PANEL
25	CREW OXYGEN
26	MAIN HYDRAULIC RESERVOIR

*INDICATES SERVICE POINTS THAT MAY NOT BE INCLUDED ON NON-CONVERTIBLE FREIGHTERS

5.4 GROUND SERVICE CONNECTIONS MODEL DC-8-43, -55, -55F

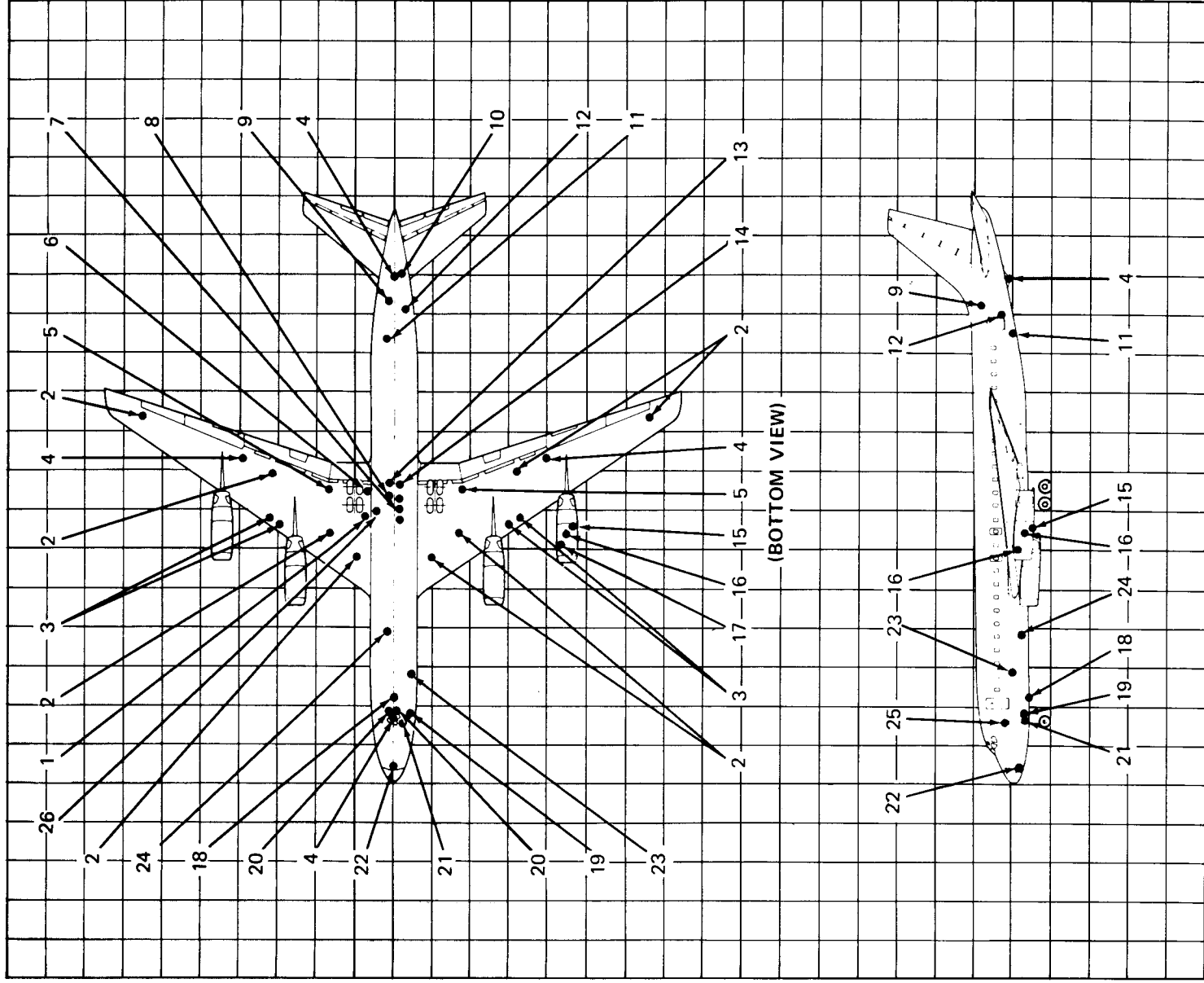

5.4 GROUND SERVICE CONNECTIONS MODEL DC-8-43, -55, -55F

ITEM NO.	DESCRIPTION
1	GROUND HYDRAULIC POWER SUPPLY AND PRESSURE FILL PORT
2	OVERWING GRAVITY REFUELING POINTS
3	PRESSURE REFUELING POINTS
4	MOORING POINT
5	WING JACK POINT
6	AUXILIARY PUMP ACCUMULATOR
7	BRAKE ACCUMULATORS (3)
8	MAIN SYSTEM ACCUMULATOR
9	*AFT WASTE DISPOSAL SERVICE PANEL
10	EMPENNAGE ACCUMULATOR
11	*AFT POTABLE WATER SERVICE PANEL (PRESSURIZED OR GRAVITY FLOW SYSTEM)
12	POTABLE WATER SERVICE PANEL (PRESSURIZED SYSTEM) OPTIONAL
13	STANDBY RUDDER ACCUMULATOR
14	SPOILER ACCUMULATOR
15	CONSTANT SPEED DRIVE (TYPICAL EACH ENGINE) EXCEPT SERIES 70
16	ENGINE OIL (TYPICAL EACH ENGINE) EXCEPT SERIES 70
17	WASTE DISPOSAL SERVICE PANEL
18	FORWARD POTABLE WATER SERVICE PANEL (GRAVITY FLOW)
19	OXYGEN SERVICE PANEL
20	FORWARD WASTE DISPOSAL SERVICE PANEL
21	ALT NOSE STEERING ACCUMULATOR
22	GROUND ELECTRIC POWER
23	PNEUMATIC POWER
24	NOSE JACK POINT
25	PRE-CONDITIONED AIR
26	MAIN HYDRAULIC RESERVOIR

* INDICATES SERVICE POINTS THAT MAY NOT BE INCLUDED ON NON-CONVERTIBLE FREIGHTERS

5.4 GROUND SERVICE CONNECTIONS

MODEL DC-8-61, -61F, -71, -71F

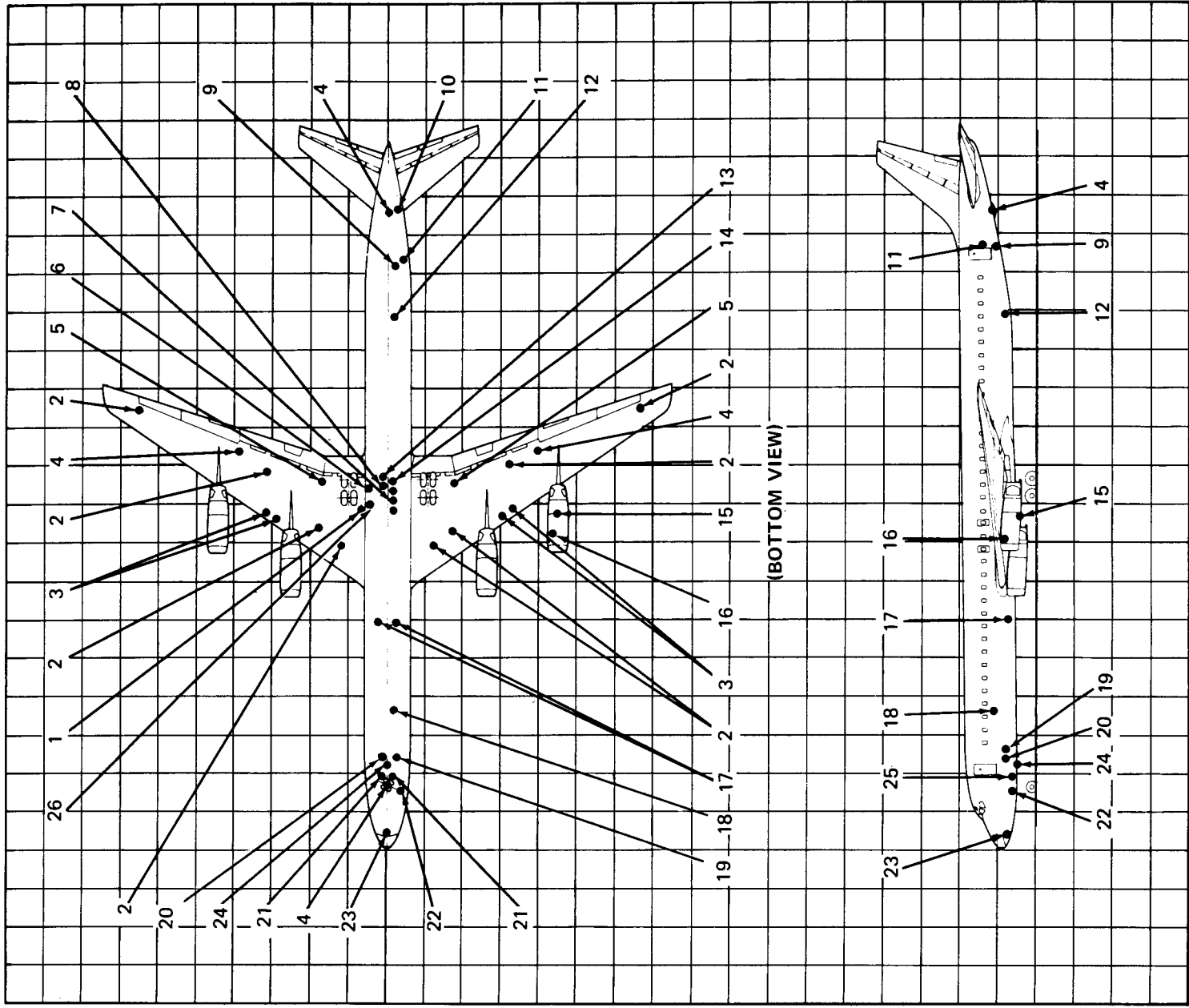

**5.4 GROUND SERVICE CONNECTIONS
MODEL DC-8-61, -61F, -71, -71F**

ITEM NO.	DESCRIPTION
1	GROUND HYDRAULIC POWER SUPPLY AND PRESSURE FILL PORT
2	OVERWING GRAVITY REFUELING POINTS
3	PRESSURE REFUELING POINTS
4	MOORING POINT
5	WING JACK POINT
6	AUXILIARY PUMP ACCUMULATOR
7	BRAKE ACCUMULATORS (3)
8	MAIN SYSTEM ACCUMULATOR
9	STANDBY RUDDER ACCUMULATOR
10	*AFT WASTE DISPOSAL SERVICE PANEL (MAY BE ON L-H OR R-H SIDE)
11	EMPENNAGE ACCUMULATOR
12	*POTABLE WATER SERVICE PANEL (PRESSURIZED OR GRAVITY FLOW SYSTEM)
13	*AFT POTABLE WATER SERVICE PANEL (PRESSURIZED SYSTEM) OPTIONAL
14	*PASSENGER OXYGEN BOTTLES
15	SPOILER ACCUMULATOR
16	THRUST REVERSER ACCUMULATOR
17	CONSTANT SPEED DRIVE (TYPICAL EACH ENGINE) EXCEPT SERIES 70
18	ENGINE OIL (TYPICAL EACH ENGINE) EXCEPT SERIES 70
19	FORWARD POTABLE WATER SERVICE PANEL (GRAVITY FLOW SYSTEM)
20	FORWARD WASTE DISPOSAL SERVICE PANEL (MAY BE ON L-H OR R-H SIDE)
21	GROUND ELECTRIC POWER
22	ALT NOSE STEERING ACCUMULATOR
23	PNEUMATIC POWER
24	NOSE JACK POINT
25	CREW OXYGEN
26	PRE-CONDITIONED AIR
27	MAIN HYDRAULIC RESERVOIR

*INDICATES SERVICE POINTS THAT MAY NOT BE INCLUDED ON NON-CONVERTIBLE FREIGHTERS

5.4 GROUND SERVICE CONNECTIONS

MODEL DC-8-62, -62F, -72, -72F

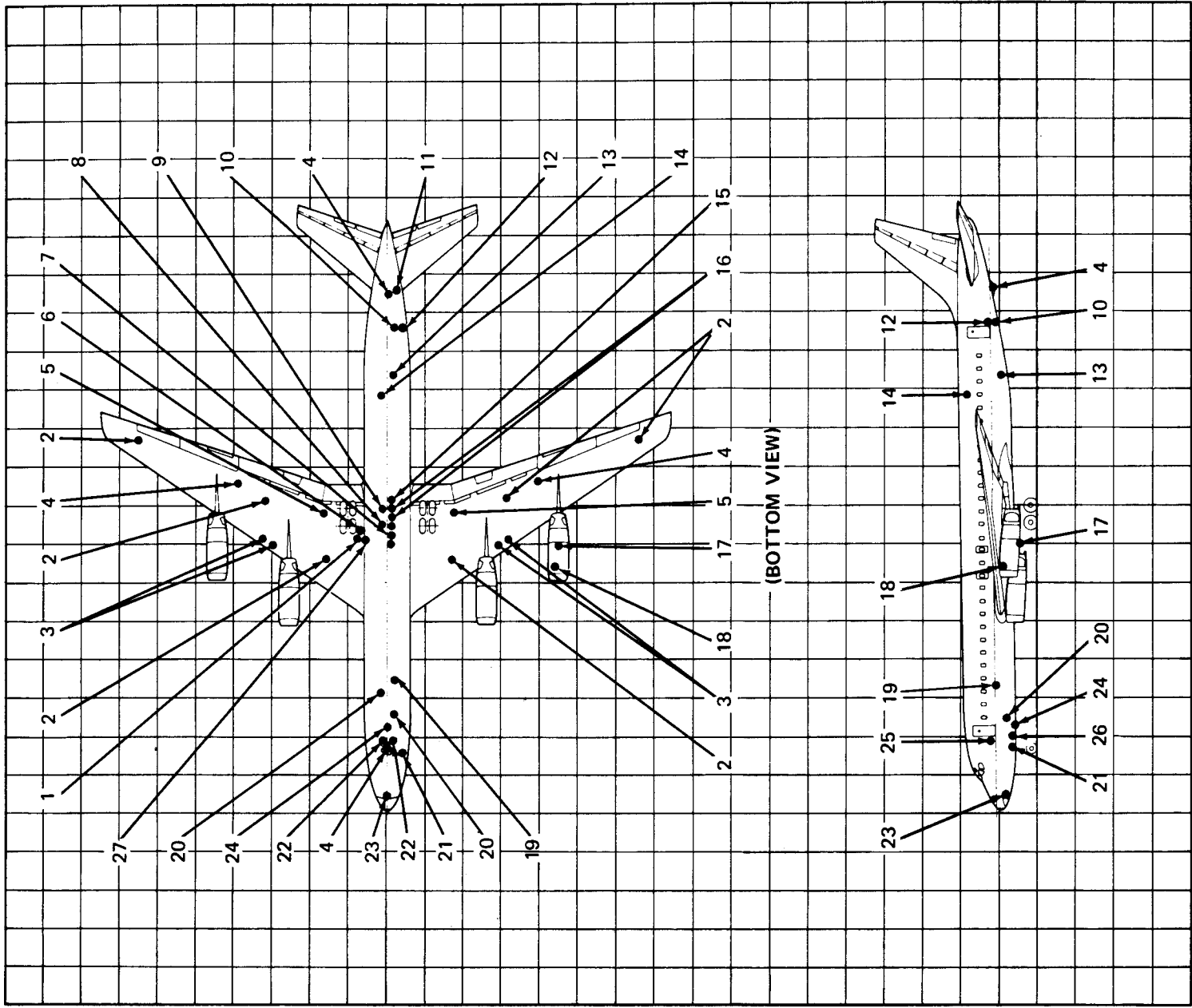

5.4 GROUND SERVICE CONNECTIONS MODEL DC-8-62, -62F, -72, -72F

ITEM NO.	DESCRIPTION
1	GROUND HYDRAULIC POWER SUPPLY AND PRESSURE FILL PORT
2	OVERWING GRAVITY REFUELING POINTS
3	PRESSURE REFUELING POINTS
4	MOORING POINT
5	WING JACK POINT
6	AUXILIARY PUMP ACCUMULATOR
7	BRAKE ACCUMULATORS (3)
8	MAIN SYSTEM ACCUMULATOR
9	STANDBY RUDDER ACCUMULATOR
10	*AFT WASTE DISPOSAL SERVICE PANEL
11	EMPENNAGE ACCUMULATOR
12	*POTABLE WATER SERVICE PANEL (GRAVITY FLOW SYSTEM OR PRESSURIZED SYSTEM)
13	*PASSENGER OXYGEN BOTTLES
14	SPOILER ACCUMULATOR
15	THRUST REVERSER ACCUMULATOR
16	CONSTANT SPEED DRIVE (TYPICAL EACH ENGINE) EXCEPT SERIES 70
17	ENGINE OIL (TYPICAL EACH ENGINE) EXCEPT SERIES 70
18	POTABLE WATER (GRAVITY FLOW SYSTEM)
19	FORWARD WASTE DISPOSAL SERVICE PANEL
20	ALT NOSE STEERING ACCUMULATOR
21	GROUND ELECTRIC POWER
22	PNEUMATIC POWER
23	NOSE JACK POINT
24	CREW OXYGEN
25	PRE-CONDITIONED AIR
26	MAIN HYDRAULIC RESERVOIR

*INDICATES SERVICE POINTS THAT MAY NOT BE INCLUDED ON NON-CONVERTIBLE FREIGHTERS

5.4 GROUND SERVICE CONNECTIONS

MODEL DC-8-63, -63F, -73, -73F

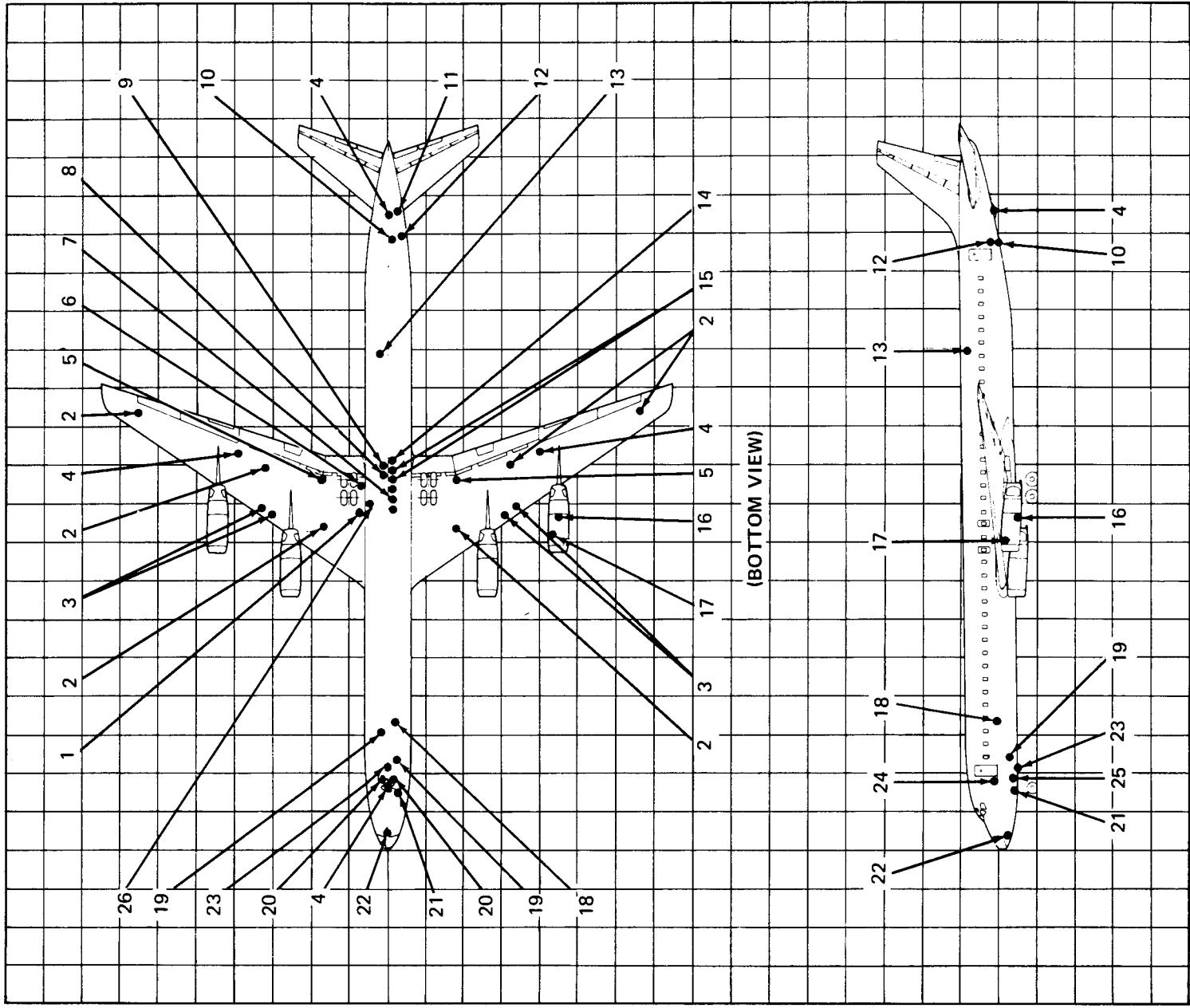

**5.4 GROUND SERVICE CONNECTIONS
MODEL DC-8-63, -63F, -73, -73F**

	DISTANCE AFT OF NOSE		DISTANCE FROM AIRPLANE CENTERLINE				HEIGHT FROM GROUND	
	FEET	METERS	RIGHT SIDE		LEFT SIDE		FEET	METERS
			FEET	METERS	FEET	METERS		
5.4.1 HYDRAULIC SYSTEM 2 SERVICE CONNECTIONS								
A. BASIC SYSTEM FILLER NECK	68.4	20.8	-	-	6.2	1.9	8.2	2.5
B. PRESSURE FILL PORT AND EXTERNAL POWER CONNECTION ACCUMULATORS	68.4	20.8	-	-	6.2	1.9	6.8	2.1
A. NOSE WHEEL STEERING ACCUMULATORS (2 EACH)	LOCATED IN NOSE WHEEL WELL							
B. BRAKE ACCUMULATORS (3 EACH)	LOCATED IN R-H MAIN WHEEL WELL							
C. SPOILER ACCUMULATOR (1 EACH)	LOCATED IN R-H MAIN WHEEL WELL							
D. STANDBY RUDDER ACCUMULATOR (1 EACH)	LOCATED IN L-H MAIN WHEEL WELL							
E. MAIN SYSTEM ACCUMULATOR (1 EACH)	LOCATED IN L-H MAIN WHEEL WELL							
F. AUXILIARY PUMP ACCUMULATOR (1 EACH)	LOCATED IN L-H MAIN WHEEL WELL							
G. EMPENNAGE ACCUMULATOR (1 EACH)	LOCATED IN TAIL SECTION OF FUSELAGE							

5.4 GROUND SERVICE CONNECTION DATA

MODEL DC-8-43, -55, -55F

	DISTANCE AFT OF NOSE		DISTANCE FROM AIRPLANE CENTERLINE				HEIGHT FROM GROUND	
	FEET	METERS	RIGHT SIDE		LEFT SIDE		FEET	METERS
			FEET	METERS	FEET	METERS		
FUEL SYSTEM (CONT)								
	LBS	KG						
FUEL CAPACITY								
INBOARD MAIN	16,800	7,620						
OUTBOARD MAIN	19,350	8,777						
INBOARD AUXILIARY	11,750	5,330						
OUTBOARD AUXILIARY	9,300	4,218						
CENTER AUXILIARY	26,100	11,890						
(OVERWATER)								
TOTAL AIRCRAFT CAPACITY	140,500	63,731						
22 FUEL TANK SUMP DRAINS								
	FEET	METERS						
A. CENTER AUX	63.8	19.4	4.8	1.5			6.3-6.9	1.9-2.1
B. NO. 3 MAIN	61.2	18.7	7.4	2.3			6.5-7.2	2.0-2.2
C. NO. 3 MAIN	63.8	19.4	7.4	2.3			6.5-7.2	2.0-2.2
D. NO. 3 MAIN	65.5	20.0	7.4	2.3			6.5-7.2	2.0-2.2
E. NO. 3 ALTERNATE	70.0	21.3	12.8	3.9			7.6-9.2	2.3-2.8
F. NO. 3 ALTERNATE	64.7	19.7	15.2	4.6			7.6-9.2	2.3-2.8
G. NO. 4 MAIN	73.0	22.3	20.0	6.1			8.3-9.2	2.5-2.8
H. NO. 4 MAIN	70.9	21.6	20.6	6.3			8.3-9.2	2.5-2.8
I. NO. 4 MAIN	68.0	20.7	22.4	6.8			8.3-9.2	2.5-2.8
J. NO. 4 ALTERNATE	76.3	23.3	41.1	12.5			11.3-12.0	3.4-3.7
K. NO. 4 ALTERNATE	79.7	24.3	41.1	12.5			11.3-12.0	3.4-3.7
L. CENTER AUX	63.8	19.4			4.8	1.5	6.3-6.9	1.9-2.1
M. NO. 2 MAIN	61.2	18.7			7.4	2.3	6.5-7.2	2.0-2.2
N. NO. 2 MAIN	63.8	19.4			7.4	2.3	6.5-7.2	2.0-2.2
O. NO. 2 MAIN	65.5	20.0			7.4	2.3	6.5-7.2	2.0-2.2
P. NO. 2 ALTERNATE	70.0	21.3			12.8	3.9	7.6-9.2	2.3-2.8
Q. NO. 2 ALTERNATE	64.7	19.7			15.2	4.6	7.6-9.2	2.3-2.8
R. NO. 1 MAIN	73.0	22.3			20.0	6.1	8.3-9.2	2.5-2.8
S. NO. 1 MAIN	70.9	21.6			20.1	6.1	8.3-9.2	2.5-2.8
T. NO. 1 MAIN	68.0	20.7			20.2	6.2	8.3-9.2	2.5-2.8
U. NO. 1 ALTERNATE	76.3	23.3			41.1	12.5	11.3-12.0	3.4-3.7
V. NO. 1 ALTERNATE	79.7	24.3			41.1	12.5	11.3-12.0	3.4-3.7
5.4.5 PNEUMATIC SYSTEM								
1 PRECONDITIONED AIR CONNECTOR (190 LBS/MIN AT 35-38 PSI)	20.3	6.2	3.8	1.2	-	-	6.7-7.4	2.0-2.3
1 GROUND POWER CONNECTOR FOR ENGINE STARTING (100 LBS/MIN AT 40 PSI AT 130°F AMBIENT)	3.3	1.0	0	0	0	0	6.4-7.3	2.0-2.2

NOTE: ENGINE START CONNECTORS MAY ALSO BE LOCATED ON LOWER R-H SIDE OF NO. 3 AND 4 ENGINE NACELLES OR ALL ENGINE NACELLES DEPENDING ON CUSTOMER CHOICE.

5.4 GROUND SERVICE CONNECTION DATA

MODEL DC-8-43, -55, -55F

	DISTANCE AFT OF NOSE		DISTANCE FROM AIRPLANE CENTERLINE				HEIGHT FROM GROUND	
	FEET	METERS	RIGHT SIDE		LEFT SIDE		FEET	METERS
			FEET	METERS	FEET	METERS		
5.4.6 POTABLE WATER SYSTEM GRAVITY FLOW SYSTEM (10 GPM AT 10 PSI) A. FORWARD (40 GAL CAPACITY) NOTE: DC-8-55F MAY HAVE ONLY A 10 GAL CAPACITY								
	28.4	8.7	5.7	1.7	--	--	11.3-12.2	3.4-3.7
B. AFT (40, 70, OR 80 GAL CAPACITY)	91.5	27.9	5.9	1.8	--	--	12.7-13.6	3.9-4.1
5.4.7 WASTE DISPOSAL SYSTEM 2 SERVICE CONNECTIONS A. FORWARD 1. PRELOADED BAGGAGE CONTAINER CONFIGURATION 2. BULKLOADING CONFIGURATION B. AFT								
	39.2	11.9	--	--	2.8	0.9	6.7-7.4	2.0-2.3
	32.5	9.9	--	--	2.8	0.9	6.7-7.4	2.0-2.3
	112.5	34.3	--	--	1.5	0.5	8.8-9.6	2.7-2.9

5.4. GROUND SERVICE CONNECTION DATA
MODEL DC-8-43, -55, -55F

	DISTANCE AFT OF NOSE		DISTANCE FROM AIRPLANE CENTERLINE				HEIGHT FROM GROUND	
	FEET	METERS	RIGHT SIDE		LEFT SIDE		FEET	METERS
			FEET	METERS	FEET	METERS		
5.4.1 HYDRAULIC SYSTEM								
2 SERVICE CONNECTIONS								
A. BASIC SYSTEM FILLER NECK	88.4	26.9	-	-	6.1	1.9	8.2	2.5
B. PRESSURE FILL PORT AND EXTERNAL POWER CONNECTION	88.4	26.9	-	-	6.2	1.9	6.8	2.1
ACCUMULATORS								
A. NOSE WHEEL STEERING ACCUMULATORS (2 EACH)	LOCATED IN NOSE WHEEL WELL							
B. BRAKE ACCUMULATORS (3 EACH)	LOCATED IN R-H MAIN WHEEL WELL							
C. SPOILER ACCUMULATOR (1 EACH)	LOCATED IN R-H MAIN WHEEL WELL							
D. STANDBY RUDDER ACCUMULATOR (1 EACH)	LOCATED IN L-H MAIN WHEEL WELL							
E. MAIN SYSTEM ACCUMULATOR (1 EACH)	LOCATED IN L-H MAIN WHEEL WELL							
F. AUXILIARY PUMP ACCUMULATOR (1 EACH)	LOCATED IN L-H MAIN WHEEL WELL							
G. EMPENNAGE ACCUMULATOR (1 EACH)	LOCATED IN TAIL SECTION OF FUSELAGE							
5.4.2 ELECTRICAL SYSTEM								
1 GROUND SERVICE CONNECTION 115/200 VAC, 400 CPS, 3 PHASE, 80 KVA	13.7	4.2	2.0	0.6	-	-	5.9-6.3	1.8-1.9

5.4 GROUND SERVICE CONNECTION DATA

MODEL DC-8-61, -61F, -71, -71F

	DISTANCE AFT OF NOSE		DISTANCE FROM AIRPLANE CENTERLINE				HEIGHT FROM GROUND	
	FEET	METERS	RIGHT SIDE		LEFT SIDE		FEET	METERS
			FEET	METERS	FEET	METERS		
5.4.3 OXYGEN SYSTEM CREW 1-111 CU FT BOTTLE PASSENGER 3-111 CU FT BOTTLES 1-74 CU FT BOTTLE NOTE: DATA SHOWN IS FOR A SINGLE POINT SERVICE FWD PANEL	25.9	7.9	-	-	2.1	0.6	6.5	2.0
5.4.4 FUEL SYSTEM 4 PRESSURE FILL SERVICE POINTS (350 GPM INITIAL FLOW AT 50 PSI)								
A. RIGHT INBOARD	87.8	26.8	31.4	9.6			10.4-10.8	3.2-3.3
B. RIGHT OUTBOARD	89.3	27.2	33.6	10.2			10.4-10.8	3.2-3.3
C. LEFT INBOARD	87.8	26.8			31.4	9.6	10.4-10.8	3.2-3.3
D. LEFT OUTBOARD	89.3	27.2			33.6	10.2	10.4-10.8	3.2-3.3
8 GRAVITY FEED FILLER INLETS								
A. NO. 3 MAIN	73.3	22.3	10.2	3.1			10.8-11.1	3.3-3.4
B. NO. 3 ALTERNATE	84.2	25.7	18.1	5.5			11.3-11.8	3.4-3.6
C. NO. 4 MAIN	96.2	29.3	32.8	10.0			12.3-12.7	3.7-3.9
D. NO. 4 ALTERNATE	112.2	34.2	63.2	19.3			14.8-15.3	4.5-4.7
E. NO. 2 MAIN	73.3	22.3			10.2	3.1	10.8-11.1	3.3-3.4
F. NO. 2 ALTERNATE	84.2	25.7			18.1	5.5	11.3-11.8	3.4-3.6
G. NO. 1 MAIN	96.2	29.3			32.8	10.0	12.3-12.7	3.7-3.9
H. NO. 1 ALTERNATE	112.2	34.2			63.2	19.3	14.8-15.3	4.5-4.7
FUEL CAPACITY INBOARD MAIN (EACH) OUTBOARD MAIN (EACH) INBOARD ALTERNATE (EACH) OUTBOARD ALTERNATE (EACH) FORWARD AUXILIARY (TOTAL) CENTER AUXILIARY (TOTAL) TOTAL AIRCRAFT CAPACITY	LBS	KG						
	17,350	7,870						
	19,940	9,045						
	12,370	5,611						
	10,320	4,681						
	8,880	4,028						
27,890	12,651							
156,730	71,093							

5.4 GROUND SERVICE CONNECTION DATA

MODEL DC-8-61, -61F, -71, -71F

	DISTANCE AFT OF NOSE		DISTANCE FROM AIRPLANE CENTERLINE				HEIGHT FROM GROUND	
	FEET	METERS	RIGHT SIDE		LEFT SIDE		FEET	METERS
			FEET	METERS	FEET	METERS		
FUEL SYSTEM (CONT) 22 FUEL TANK SUMP DRAINS								
A. CENTER AUX	83.8	25.5	4.3	1.3			6.4-6.7	2.0
B. NO. 3 MAIN	81.2	24.7	7.5	2.3			6.6-7.1	2.0-2.2
C. NO. 3 MAIN	83.8	25.5	7.5	2.3			6.6-7.1	2.0-2.2
D. NO. 3 MAIN	85.5	26.1	7.5	2.3			6.6-7.1	2.0-2.2
E. NO. 3 ALTERNATE	90.0	27.4	13.4	4.1			7.5-8.2	2.3-2.5
F. NO. 3 LATERNATE	84.7	25.8	15.3	4.7			7.5-8.2	2.3-2.5
G. NO. 4 MAIN	93.0	28.3	20.1	6.1			8.5-9.3	2.6-2.8
H. NO. 4 MAIN	90.7	27.6	21.0	6.4			8.5-9.3	2.6-2.8
I. NO. 4 MAIN	88.0	26.8	22.6	6.9			8.5-9.3	2.6-2.8
J. NO. 4 ALTERNATE	96.3	29.4	41.0	12.5			11.3-11.8	3.4-3.6
K. NO. 4 ALTERNATE	99.7	30.4	41.0	12.5			11.3-11.8	3.4-3.6
L. CENTER AUX	83.8	25.5			4.3	1.3	6.4-6.7	2.0
M. NO. 2 MAIN	81.2	24.7			7.5	2.3	6.6-7.1	2.0-2.2
N. NO. 2 MAIN	83.8	25.5			7.5	2.3	6.6-7.1	2.0-2.2
O. NO. 2 MAIN	85.5	26.1			7.5	2.3	6.6-7.1	2.0-2.2
P. NO. 2 ALTERNATE	90.0	27.4			13.4	4.1	7.5-8.2	2.3-2.5
Q. NO. 2 ALTERNATE	84.7	25.8			15.3	4.7	7.5-8.2	2.3-2.5
R. NO. 1 MAIN	93.0	28.3			20.1	6.1	8.5-9.3	2.6-2.8
S. NO. 1 MAIN	90.7	27.6			21.0	6.4	8.5-9.3	2.6-2.8
T. NO. 1 MAIN	88.0	26.8			22.6	6.9	8.5-9.3	2.6-2.8
W. NO. 1 ALTERNATE	96.3	29.4			41.0	12.5	11.3-11.8	3.4-3.6
X. NO. 1 ALTERNATE	99.7	30.4			41.0	12.5	11.3-11.8	3.4-3.6
5.4.5 PNEUMATIC SYSTEM 1 PRECONDITIONED AIR CONNECTOR (190 LBS/MIN AT 35-38 PSI)	20.4	6.2	3.8	1.2	-	-	6.9-7.3	2.1-2.2
1 GROUND POWER CONNECTOR FOR ENGINE STARTING 100 LBS/MIN AT 40 PSI AT 130°F AMBIENT	3.3	1.0	0	0	0	0	6.7-7.0	2.0-2.1
5.4.6 POTABLE WATER SYSTEMS GRAVITY FLOW SYSTEM (10 GPM AT 10 PSI) A. FORWARD 40 GAL CAPACITY NOTE: THE DC-8-61F MAY HAVE ONLY A 10 GAL CAPACITY B. AFT (80 GAL CAPACITY)	34.2	10.4	5.4	1.6	-	-	11.2-11.6	3.4-3.5
	156.0	47.5	3.7	1.1	-	-	12.7-13.7	3.9-4.2

5.4 GROUND SERVICE CONNECTION DATA

MODEL DC-8-61, -61F, -71, -71F

	DISTANCE AFT OF NOSE		DISTANCE FROM AIRPLANE CENTERLINE				HEIGHT FROM GROUND		
	FEET	METERS	RIGHT SIDE		LEFT SIDE		FEET	METERS	
			FEET	METERS	FEET	METERS			
POTABLE WATER SYSTEMS (CONT) PRESSURIZED SYSTEM (OPTIONAL) 50 PSI MAX 100 GAL CAPACITY									
A. FORWARD	145.8	44.4	1.2	0.4	—	—	8.2–9.1	2.5–2.8	
B. AFT	156.0	47.5	3.7	1.1	—	—	12.8–13.8	3.9–4.2	
5.4.7 WASTE DISPOSAL SYSTEM 3 SERVICE CONNECTIONS									
A. FORWARD	23.3	7.1	SERVICE POINTS MAY BE ON LEFT OR RIGHT SIDE			2.8	0.85	7.5–7.9	2.3–2.4
B. MIDDLE	57.6	17.6	DEPENDENT ON CUSTOMER CHOICE			2.8	0.85	7.9–8.4	2.4–2.6
C. AFT	155.8	47.5			3.8	1.2	10.6–11.6	3.2–3.5	

5.4 GROUND SERVICE CONNECTION DATA

MODEL DC-8-61, -61F, -71, -71F

	DISTANCE AFT OF NOSE		DISTANCE FROM AIRPLANE CENTERLINE				HEIGHT FROM GROUND	
	FEET	METERS	RIGHT SIDE		LEFT SIDE		FEET	METERS
			FEET	METERS	FEET	METERS		
5.4.1 HYDRAULIC SYSTEM								
2 SERVICE CONNECTIONS								
A. BASIC SYSTEM FILLER NECK	71.7	21.8			6.1	1.9	8.2	2.5
B. PRESSURE FILL PORT AND EXTERNAL POWER CONNECTION	71.7	21.8	--	--	6.2	1.9	6.8	2.1
ACCUMULATORS								
A. NOSE WHEEL STEERING ACCUMULATORS (2 EACH)								
B. BRAKE ACCUMULATORS (3 EACH)								
C. SPOILER ACCUMULATOR (1 EACH)								
D. STANDBY RUDDER ACCUMULATOR (1 EACH)								
E. MAIN SYSTEM ACCUMULATOR (1 EACH)								
F. AUXILIARY PUMP ACCUMULATOR (1 EACH)								
G. EMPENNAGE ACCUMULATOR (1 EACH)								
H. THRUST REVERSER ACCUMULATORS (2 EACH)								

LOCATED IN NOSE WHEEL WELL

LOCATED IN R-H MAIN WHEEL WELL

LOCATED IN R-H MAIN WHEEL WELL

LOCATED IN L-H MAIN WHEEL WELL

LOCATED IN L-H MAIN WHEEL WELL

LOCATED IN L-H MAIN WHEEL WELL

LOCATED IN TAIL SECTION OF FUSELAGE

LOCATED IN R-H MAIN WHEEL WELL

5.4 GROUND SERVICE CONNECTION DATA

MODEL DC-8-62, -62F, -72, -72F

	DISTANCE AFT OF NOSE		DISTANCE FROM AIRPLANE CENTERLINE				HEIGHT FROM GROUND	
	FEET	METERS	RIGHT SIDE		LEFT SIDE		FEET	METERS
			FEET	METERS	FEET	METERS		
5.4.2 ELECTRICAL SYSTEM								
1 GROUND SERVICE CONNECTION 115/200 VAC, 400 CPS, 3 PHASE, 80 KVA	13.7	4.2	2.0	0.6	—	—	5.9–6.3	1.8–1.9
5.4.3 OXYGEN SYSTEM								
<u>CREW</u>								
1-74 CU FT BOTTLE	22.5	6.9	4.9	1.5	—	—	10.1–10.8	3.1–3.3
<u>PASSENGER</u>								
2-111 CU FT BOTTLES (EMERG) 1-74 CU FT BOTTLE (FIRST AID)	110.0	33.5	1.9	0.6	—	—	18.3–19.3	5.6–5.9
NOTE: O ₂ BOTTLES MUST BE REMOVED FROM AIRCRAFT FOR SERVICING								
5.4.4 FUEL SYSTEM								
4 PRESSURE FILL SERVICE POINTS (350 GPM INITIAL FLOW @ 50 PSI)								
A. RIGHT INBOARD	71.2	21.7	31.4	9.6			10.5–11.3	3.2–3.4
B. RIGHT OUTBOARD	72.7	22.2	33.6	10.2	31.4	9.6	10.5–11.3	3.2–3.4
C. LEFT INBOARD	71.2	21.7			33.6	10.2	10.5–11.3	3.2–3.4
D. LEFT OUTBOARD	72.7	22.2					10.5–11.3	3.2–3.4
8 GRAVITY FEED FILLER INLETS								
A. 3 MAIN	67.5	20.6	10.2	3.1			11.4–11.8	3.5–3.6
B. 4 MAIN	73.5	22.4	32.8	10.0			12.4–12.9	3.8–3.9
C. 4 ALTERNATE	95.5	29.1	63.2	19.3			15.1–15.7	4.6–4.8
D. 2 MAIN	67.5	20.6			10.2	3.1	11.4–11.8	3.5–3.6
E. 1 MAIN	73.5	22.4			32.8	10.0	12.4–12.9	3.8–3.9
F. 1 ALTERNATE	95.5	29.1			63.2	19.3	15.1–15.7	4.6–4.8

LOCATED ON THE FLOOR OF GALLEY UNIT 5

5.4 GROUND SERVICE CONNECTION DATA MODEL DC-8-62, -62F, -72, -72F

	DISTANCE AFT OF NOSE		DISTANCE FROM AIRPLANE CENTERLINE				HEIGHT FROM GROUND	
	FEET	METERS	RIGHT SIDE		LEFT SIDE		FEET	METERS
			FEET	METERS	FEET	METERS		
FUEL SYSTEM (CONTINUED)								
FUEL CAPACITY	LBS	KG						
INBOARD MAIN (EACH)	29,842	13,536						
OUTBOARD MAIN (EACH)	19,940	9,045						
OUTBOARD ALTERNATE (EACH)	10,800	4,899						
FORWARD ALTERNATE (EACH)	13,447	6,100						
CENTER AUXILIARY (TOTAL)	28,053	12,725						
TOTAL ACFT CAPACITY	162,664	73,784						
8 FUEL TANK SUMP DRAINS	FEET	METERS						
A. CENTER AUXILIARY	67.1	20.5	4.3	1.3			6.4-6.7	2.0
B. 3 MAIN	64.5	19.7	7.5	2.3			6.6-7.1	2.0-2.2
C. 3 MAIN	67.1	20.5	7.5	2.3			6.6-7.1	2.0-2.2
D. 3 MAIN	68.8	21.0	7.5	2.3			6.6-7.1	2.0-2.2
E. 4 MAIN	76.3	23.3	20.1	6.1			8.5-9.3	2.6-2.8
F. 4 MAIN	74.2	22.6	21.0	6.4			8.5-9.3	2.6-2.8
G. 4 MAIN	71.3	21.7	22.6	6.9			8.5-9.3	2.6-2.8
H. 4 ALTERNATE	79.6	24.3	41.0	12.5			11.3-11.8	3.4-3.6
I. 4 ALTERNATE	83.0	25.3	41.0	12.5			11.3-11.8	3.4-3.6
J. CENTER AUXILIARY	67.1	20.5			4.3	1.3	6.4-6.7	2.0
K. 2 MAIN	64.5	19.7			7.5	2.3	6.6-7.1	2.0-2.2
L. 2 MAIN	67.1	20.5			7.5	2.3	6.6-7.1	2.0-2.2
M. 2 MAIN	68.8	21.0			7.5	2.3	6.6-7.1	2.0-2.2
N. 1 MAIN	76.3	23.3			20.1	6.1	8.5-9.3	2.6-2.8
O. 1 MAIN	74.2	22.6			21.0	6.4	8.5-9.3	2.6-2.8
P. 1 MAIN	71.3	21.7			22.6	6.9	8.5-9.3	2.6-2.8
Q. 1 ALTERNATE	79.6	24.3			41.0	12.5	11.3-11.8	3.4-3.6
R. 1 ALTERNATE	83.0	25.3			41.0	12.5	11.3-11.8	3.4-3.6
5.4.5 PNEUMATIC SYSTEM								
1 PRECONDITIONED AIR CONNECTOR								
(190 LB/MIN AT 35-38 PSI)	20.4	6.2	3.8	1.2	-	-	7.1	2.2
1 GROUND POWER CONNECTOR FOR ENGINE STARTING								
100 LB/MIN AT 40 PSI AT 130°F AMBIENT	3.3	1.0	0	0	0	0	6.8	2.1

5.4 GROUND SERVICE CONNECTION DATA

MODEL DC-8-62, -62F, -72, -72F

	DISTANCE AFT OF NOSE		DISTANCE FROM AIRPLANE CENTERLINE				HEIGHT FROM GROUND	
	FEET	METERS	RIGHT SIDE		LEFT SIDE		FEET	METERS
			FEET	METERS	FEET	METERS		
5.4.6 POTABLE WATER SYSTEMS GRAVITY FLOW SYSTEM (10 GPM AT 10 PSI) A. FORWARD (40 GAL CAPACITY) NOTE: THE DC-8-62F MAY HAVE ONLY A 10 GAL CAPACITY B. AFT (40, 70, OR 80 GAL CAPACITY) PRESSURIZED SYSTEM (OPTIONAL) 50 PSI MAX 100 GAL CAPACITY	34.2	10.4	5.4	1.6	—	—	11.2–11.5	3.4–3.5
	126.0	38.4	3.7	1.1	—	—	12.8–14.0	3.9–4.3
A. FORWARD B. AFT WASTE DISPOSAL SYSTEM 3 SERVICE CONNECTIONS	115.8 126.0	35.3 38.4	1.2 3.7	0.4 1.1	—	—	8.2–9.3 12.9–14.0	2.5–2.8 3.9–4.3
	23.3 125.8	7.1 38.3	SERVICE PANELS MAY BE ON LEFT OR RIGHT SIDE OF AIRCRAFT DEPENDING ON CUSTOMER'S CHOICE		2.8 3.8	0.9 1.2	7.5–7.8 11.0–12.2	2.3–2.4 3.4–3.7

5.4 GROUND SERVICE CONNECTION DATA
MODEL DC-8-62, -62F, -72, -72F

	DISTANCE AFT OF NOSE		DISTANCE FROM AIRPLANE CENTERLINE				HEIGHT FROM GROUND	
	FEET	METERS	RIGHT SIDE		LEFT SIDE		FEET	METERS
			FEET	METERS	FEET	METERS		
5.4.1 HYDRAULIC SYSTEM 2 SERVICE CONNECTIONS								
A. BASIC SYSTEM FILLER NECK	88.4	26.9	-	-	6.1	1.9	8.2	2.5
B. PRESSURE FILL PORT AND EXTERNAL POWER CONNECTION ACCUMULATORS	88.4	26.9	-	-	6.2	1.9	6.8	2.1
A. NOSE WHEEL STEERING ACCUMULATORS (2 EACH)	LOCATED IN NOSE WHEEL WELL							
B. BRAKE ACCUMULATORS (3 EACH)	LOCATED IN R-H MAIN WHEEL WELL							
C. SPOILER ACCUMULATOR (1 EACH)	LOCATED IN R-H MAIN WHEEL WELL							
D. STANDBY RUDDER ACCUMULATOR (1 EACH)	LOCATED IN L-H MAIN WHEEL WELL							
E. MAIN SYSTEM ACCUMULATOR (1 EACH)	LOCATED IN L-H MAIN WHEEL WELL							
F. AUXILIARY PUMP ACCUMULATOR (1 EACH)	LOCATED IN L-H MAIN WHEEL WELL							
G. EMPENNAGE ACCUMULATOR (1 EACH)	LOCATED IN TAIL SECTION OF FUSELAGE							
H. THRUST REVERSER ACCUMULATORS (2 EACH)	LOCATED IN R-H MAIN WHEEL WELL							
5.4.2 ELECTRICAL SYSTEM 1 GROUND SERVICE CONNECTION 115/200 VAC, 400 CPS, 3 PHASE, 80 KVA	13.7	4.2	2.0	0.6	-	-	5.9-6.3	1.8-1.9

5.4 GROUND SERVICE CONNECTION DATA

MODEL DC-8-63, -63F, -73, -73F

	DISTANCE AFT OF NOSE		DISTANCE FROM AIRPLANE CENTERLINE				HEIGHT FROM GROUND	
	FEET	METERS	RIGHT SIDE		LEFT SIDE		FEET	METERS
			FEET	METERS	FEET	METERS		
5.4.3 OXYGEN SYSTEM								
CREW 1-74 CU FT BOTTLE	22.5	6.9	4.9	1.5	--	--	10.4-10.8	3.2-3.3
PASSENGER 2-111 CU FT BOTTLES (EMERGENCY)	125.8	38.3	.5	.2	--	--	18.2-19.0	5.5-5.8
1-111 CU FT BOTTLE (FIRST AID)	LOCATED ON FLOOR OF GALLEY UNIT 5							
NOTE: O ₂ BOTTLES MUST BE REMOVED FROM AIRCRAFT FOR SERVICING								
5.4.4 FUEL SYSTEM								
4 PRESSURE FILL SERVICE POINTS (350 GPM INITIAL FLOW AT 50 PSI)								
A. RIGHT INBOARD	87.8	26.8	31.4	9.6	--	--	10.4-11.1	3.2-3.4
B. RIGHT OUTBOARD	89.3	27.2	33.6	10.2	--	--	10.4-11.1	3.2-3.4
C. LEFT INBOARD	87.8	26.8	--	--	31.4	9.6	10.4-11.1	3.2-3.4
D. LEFT OUTBOARD	89.3	27.2	--	--	33.6	10.2	10.4-11.1	3.2-3.4
8 GRAVITY FEED FILLER INLETS								
A. NO. 3 MAIN	84.2	25.7	10.2	3.1			11.4-11.8	3.5-3.6
B. NO. 4 MAIN	96.2	29.3	32.8	10.0			12.3-12.7	3.7-3.9
C. NO. 4 ALTERNATE	112.2	34.2	63.2	19.3			14.8-15.3	4.5-4.7
D. NO. 2 MAIN	84.2	25.7			10.2	3.1	11.4-11.8	3.5-3.6
E. NO. 1 MAIN	96.2	29.3			32.8	10.0	12.3-12.7	3.7-3.9
F. NO. 1 ALTERNATE	112.2	34.2			63.2	19.3	14.8-15.3	4.5-4.7
FUEL CAPACITY	LBS	KG						
INBOARD MAIN (EACH)	29,842	13,536						
OUTBOARD MAIN (EACH)	19,940	9,045						
OUTBOARD ALTERNATE (EACH)	10,800	4,899						
FORWARD AUXILIARY (TOTAL)	13,447	6,100						
CENTER AUXILIARY (TOTAL)	28,053	12,725						
TOTAL AIRCRAFT CAPACITY	162,664	73,784						

5.4 GROUND SERVICE CONNECTION DATA

MODEL DC-8-63, -63F, -73, -73F

	DISTANCE AFT OF NOSE		DISTANCE FROM AIRPLANE CENTERLINE				HEIGHT FROM GROUND	
	FEET	METERS	RIGHT SIDE		LEFT SIDE		FEET	METERS
			FEET	METERS	FEET	METERS		
FUEL SYSTEM (CONT) 18 FUEL TANK SUMP DRAINS								
A. CENTER AUXILIARY	83.8	25.5	4.3	1.3			6.4-6.7	2.0
B. NO. 3 MAIN	81.2	24.7	7.5	2.3			6.6-7.1	2.0-2.2
C. NO. 3 MAIN	83.8	25.5	7.5	2.3			6.6-7.1	2.0-2.2
D. NO. 3 MAIN	85.5	26.1	7.5	2.3			6.6-7.1	2.0-2.2
E. NO. 4 MAIN	93.0	28.3	20.1	6.1			8.5-9.3	2.6-2.8
F. NO. 4 MAIN	90.7	27.6	21.0	6.4			8.5-9.3	2.6-2.8
G. NO. 4 MAIN	88.0	26.8	22.6	6.9			8.5-9.3	2.6-2.8
H. NO. 4 ALTERNATE	96.3	29.4	41.0	12.5			11.3-11.8	3.4-3.6
I. NO. 4 ALTERNATE	99.7	30.4	41.0	12.5			11.3-11.8	3.4-3.6
J. CENTER AUXILIARY	83.8	25.5			4.3	1.3	6.4-6.7	2.0
K. NO. 2 MAIN	81.2	24.7			7.5	2.3	6.6-7.1	2.0-2.2
L. NO. 2 MAIN	83.8	25.5			7.5	2.3	6.6-7.1	2.0-2.2
M. NO. 2 MAIN	85.5	26.1			7.5	2.3	6.6-7.1	2.0-2.2
N. NO. 1 MAIN	93.0	28.3			20.1	6.1	8.5-9.3	2.6-2.8
O. NO. 1 MAIN	90.7	27.6			21.0	6.4	8.5-9.3	2.6-2.8
P. NO. 1 MAIN	88.0	26.8			22.6	6.9	8.5-9.3	2.6-2.8
Q. NO. 1 ALTERNATE	96.3	29.4			41.0	12.5	11.3-11.8	3.4-3.6
R. NO. 1 ALTERNATE	99.7	30.4			41.0	12.5	11.3-11.8	3.4-3.6
5.4.5 PNEUMATIC SYSTEM 1 PRECONDITIONED AIR CONNECTOR								
(190 LBS/MIN AT 35-38 PSI)	20.4	6.2	3.8	1.2			6.9-7.3	2.1-2.2
1 GROUND POWER CONNECTOR FOR ENGINE STARTING								
100 LBS/MIN AT 40 PSI AT 130°F AMBIENT	3.3	1.0	0	0	0	0	6.7-7.0	2.0-2.1
5.4.6 POTABLE WATER SYSTEM GRAVITY FLOW SYSTEM (10 GPM at 10 PSI)								
A. FORWARD (40 GAL CAPACITY)	34.2	10.4	5.4	1.6	-	-	11.2-11.6	3.4-3.5
NOTE: THE DC-8-63F MAY HAVE ONLY A 10 GAL CAPACITY								
B. AFT (40, 70, OR 80 GAL CAPACITY)	156.0	47.5	3.7	1.1	-	-	12.7-13.7	3.9-4.2
PRESSURIZED SYSTEM (OPTIONAL)								
(50 PSI 100 GAL CAPACITY) AFT	156.0	47.5	3.7	1.1	-	-	12.8-13.8	3.9-4.2

5.4 GROUND SERVICE CONNECTION DATA

MODEL DC-8-63, -63F, -73, -73F

	DISTANCE AFT OF NOSE		DISTANCE FROM AIRPLANE CENTERLINE				HEIGHT FROM GROUND	
	FEET	METERS	RIGHT SIDE		LEFT SIDE		FEET	METERS
			FEET	METERS	FEET	METERS		
5.4.7 WASTE DISPOSAL SYSTEM								
2 SERVICE CONNECTIONS								
A. FORWARD	23.3	7.1					7.5-7.9	2.3-2.4
			SERVICE CONNECTIONS MAY BE ON LEFT OR RIGHT SIDE DEPENDING ON CUSTOMER'S CHOICE.					
B. AFT	155.8	47.5			3.8	1.2	10.6-11.6	3.2-3.5

5.4 GROUND SERVICE CONNECTION DATA
MODEL DC-8-63, -63F, -73, -73F

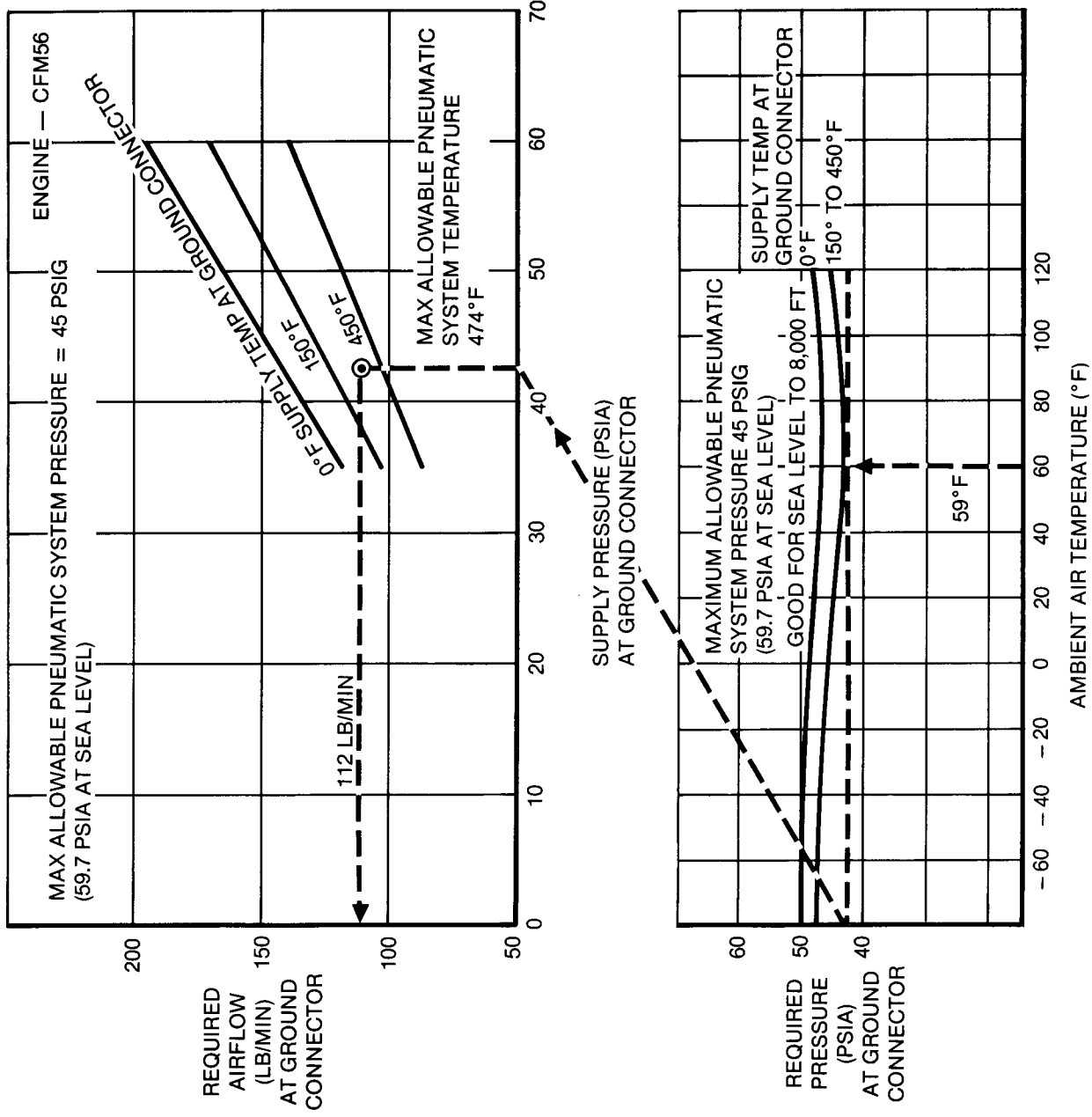

EXAMPLE

AMBIENT TEMPERATURE = 59° F
 GROUND CONNECTOR TEMP = 316° F
 REQUIRED PRESSURE
 AT GROUND CONNECTOR = 42.2 PSIA
 REQUIRED AIRFLOW AT GROUND
 CONNECTOR = 112 LB/MIN

5.5 ENGINE STARTING PNEUMATIC REQUIREMENTS
MODEL DC-8-71, -72, -73

1. INITIAL CABIN TEMPERATURE: 0°F (-17.8°C)
2. OUTSIDE AIR TEMPERATURE: -40°F (-40°C)
3. TEMPERATURE AT GROUND CONN.: 300°F (149°C)
4. PRESSURE AT GROUND CONN.: 25 PSIG
5. NO GALLEY OR OTHER HEAT LOADS IN CABIN

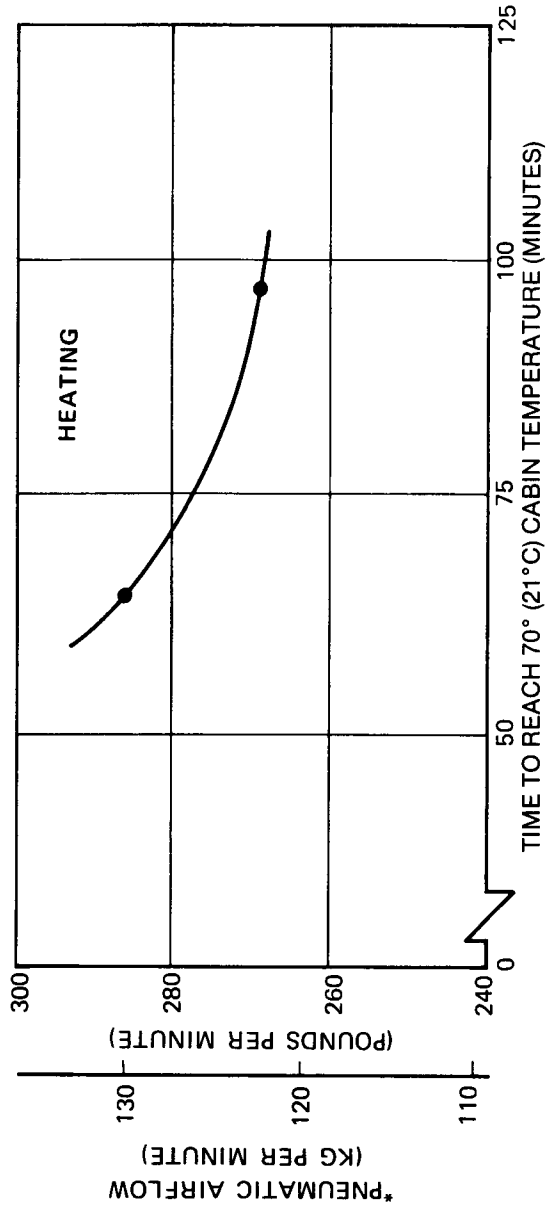

*PNEUMATIC AIR IS EXHAUSTED OVERBOARD AFTER LEAVING TURBO-COMPRESSORS.
 OUTSIDE AIR HEATED BY COMPRESSORS GOES TO THE CABIN

1. INITIAL CABIN TEMPERATURE: 103°F (39.4°C)
2. OUTSIDE AIR TEMPERATURE: 103°F (39.4°C)
3. TEMPERATURE AT GROUND CONN.: 410°F (210°C)
4. NO PASSENGERS OR CREW IN CABIN
5. NO ELECTRIC LOAD
6. MAXIMUM SOLAR RADIATION

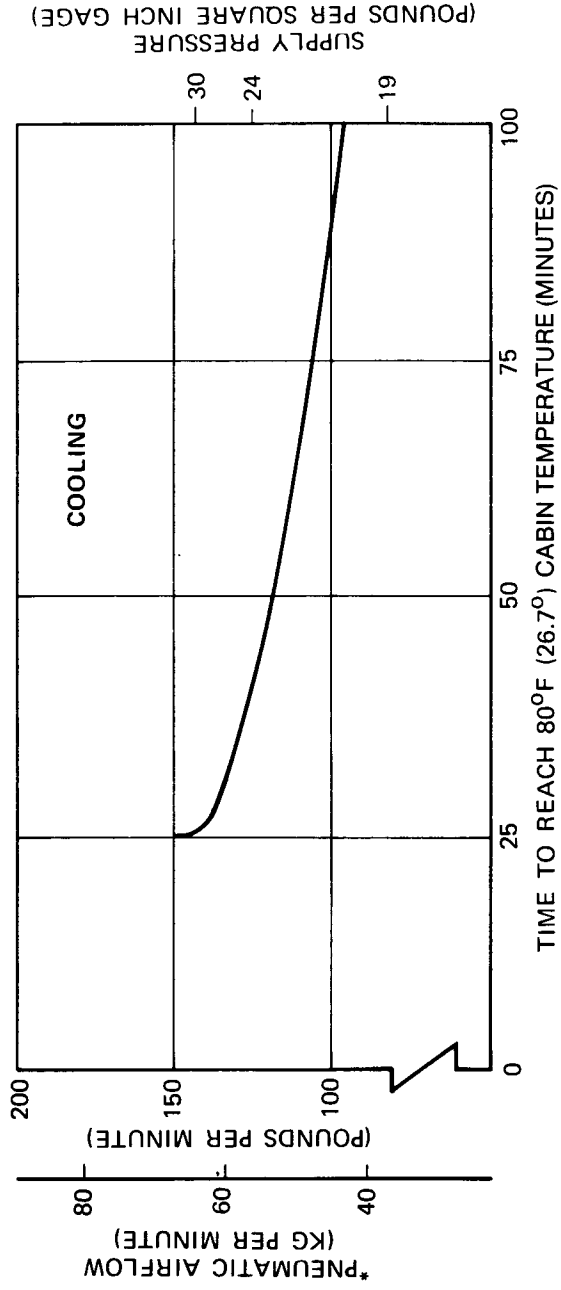

*PNEUMATIC AIR IS EXHAUSTED OVERBOARD AFTER LEAVING FREON COMPRESSORS. CABIN AIR IS RECIRCULATED BY 3 RECIRCULATING FANS

5.6 GROUND PNEUMATIC POWER REQUIREMENTS MODEL DC-8 (ALL SERIES)

1. CABIN AT 75°F, PASS. + ATTN = 257, NO GALLEY LOAD BRIGHT DAY SOLAR & ELECTRIC LOAD.
2. CABIN AT 80°F – OTHERWISE THE SAME AS (1).
3. CABIN AT 70°F, NO PASS. OR ATTN OTHERWISE THE SAME AS (1).

4, 5, & 6. CABIN AT 75°F, NO PASS. OR ATTN TO OTHER HEAT LOADS.

*MAX WITH CABIN DOORS CLOSED
32 IN. H₂O MAX IF DOORS OPEN.

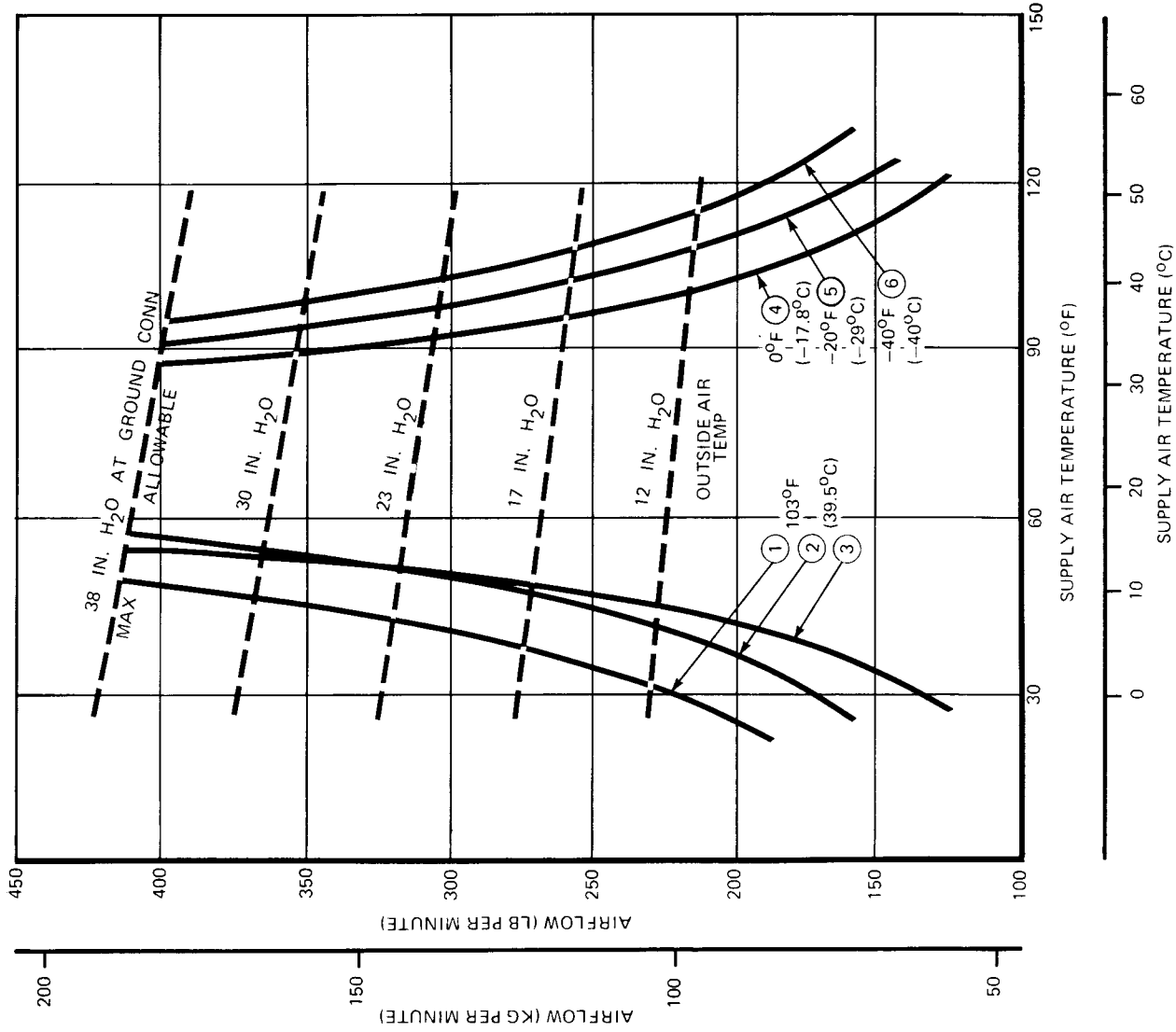

5.7 PRECONDITIONED AIRFLOW REQUIREMENTS MODEL DC-8-61, -63, -71, AND -73

1. CABIN AT 75°F, PASSENGERS AND ATTENDANTS = 194,
NO GALLEY LOAD, BRIGHT DAY SOLAR AND ELECTRIC LOAD
2. CABIN AT 80°F – OTHERWISE THE SAME AS (1).
3. CABIN AT 70°F, NO PASSENGERS OR ATTENDANTS –
OTHERWISE THE SAME AS (1).
- 4, 5, & 6. CABIN AT 75°F, NO PASSENGERS OR ATTENDANTS AND
NO OTHER HEAT LOADS

*MAXIMUM WITH CABIN DOORS CLOSED
27 IN. H₂O MAXIMUM IF DOORS OPEN

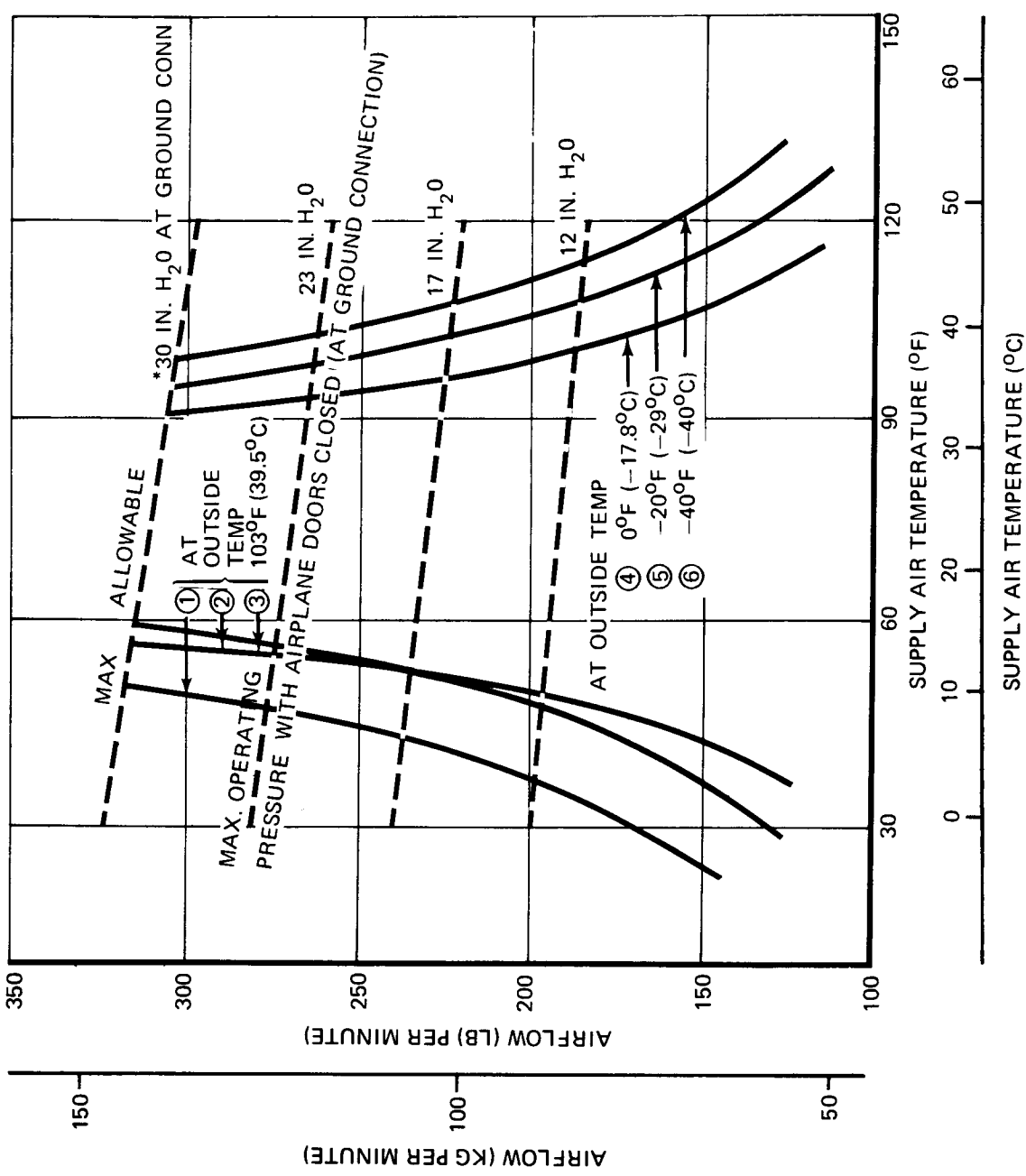

5.7 PRECONDITIONED AIRFLOW REQUIREMENTS MODEL DC-8-43, -55, -62 AND -72

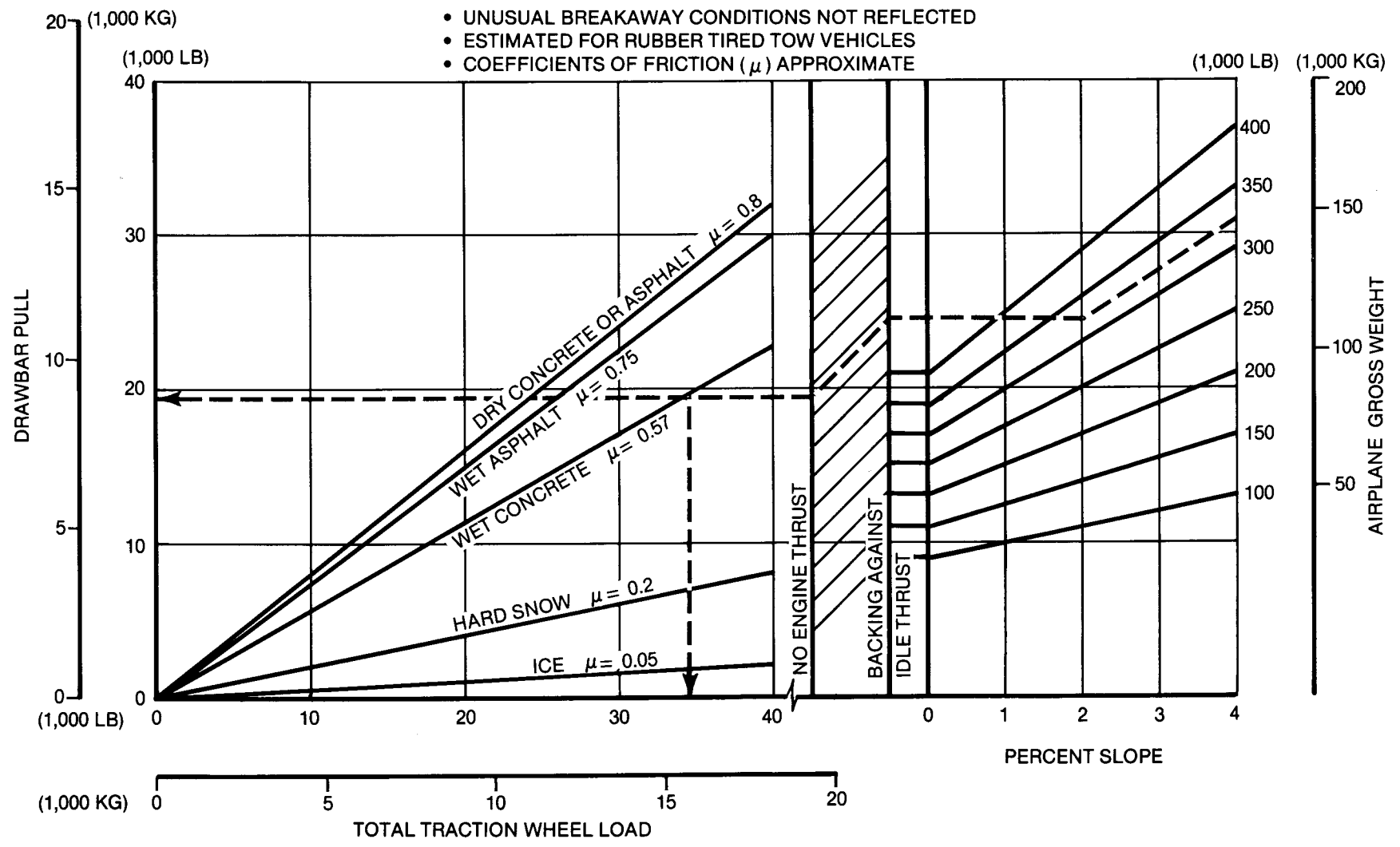

5.8 GROUND TOWING REQUIREMENTS MODEL DC-8

NOTE: SEA LEVEL STATIC, STANDARD DAY, ZERO RAMP GRADIENT, ZERO WIND, JT3D, OR RC₀ ENGINES
 AVERAGE THRUST – JT3D @ 3400 LBS (1542 KG)
 RC₀ 12 – 3150 LBS (1429 KG)
 ALL VELOCITY VALUES ARE MILES PER HR

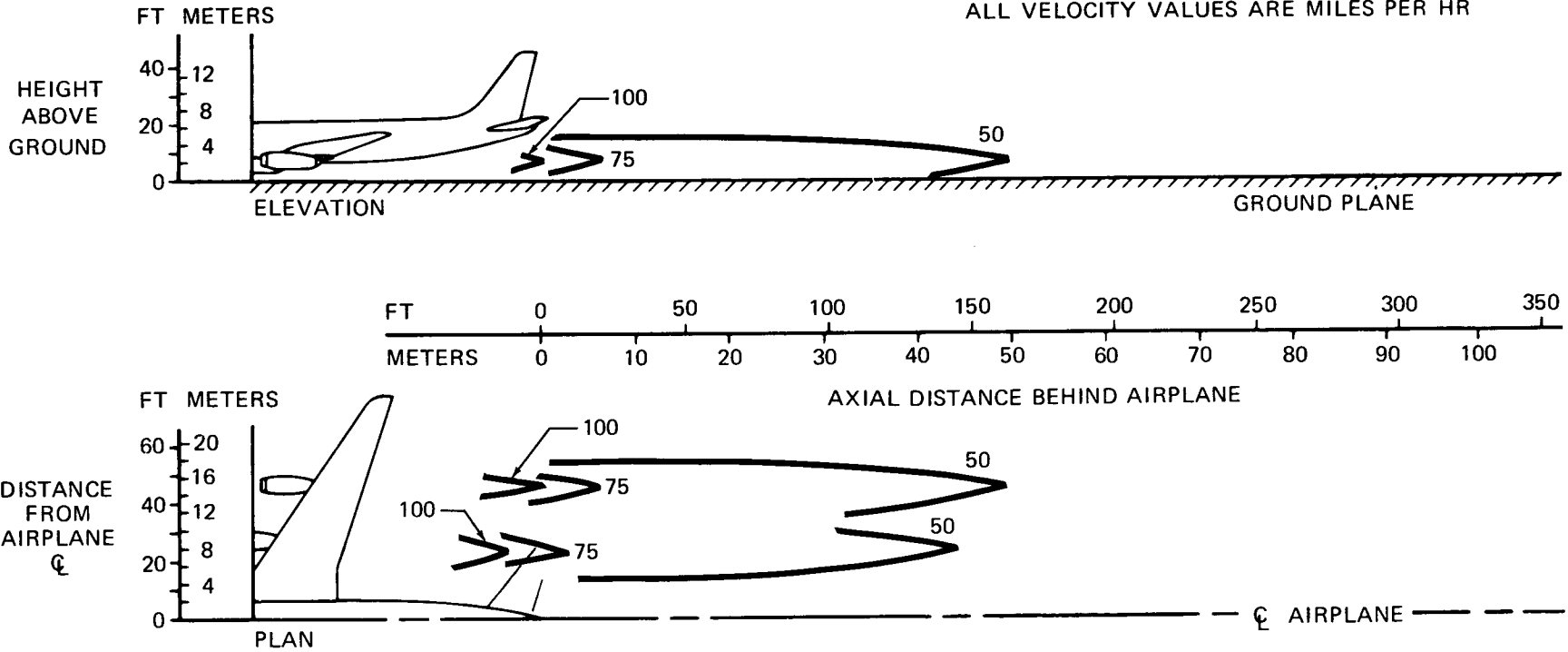

CONVERSION FACTOR: 1 MPH = 1.6 KM PER HR

6.0 OPERATING CONDITIONS

6.1 JET ENGINE EXHAUST VELOCITIES AND TEMPERATURES

6.1.1 JET ENGINE EXHAUST VELOCITY CONTOURS, BREAKAWAY POWER

MODEL DC-8, -43, -55, -61, -62, -63

NOTE: SEA LEVEL STATIC, STANDARD DAY, ZERO RAMP GRADIENT, ZERO WIND, CFM56-2C ENGINE AVERAGE THRUST — 3,400 LB/ENGINE THRUST SETTING TO OVERCOME COLD TIRE CONDITION ALL VELOCITY VALUES ARE MILES PER HR ZERO STEERING ANGLE

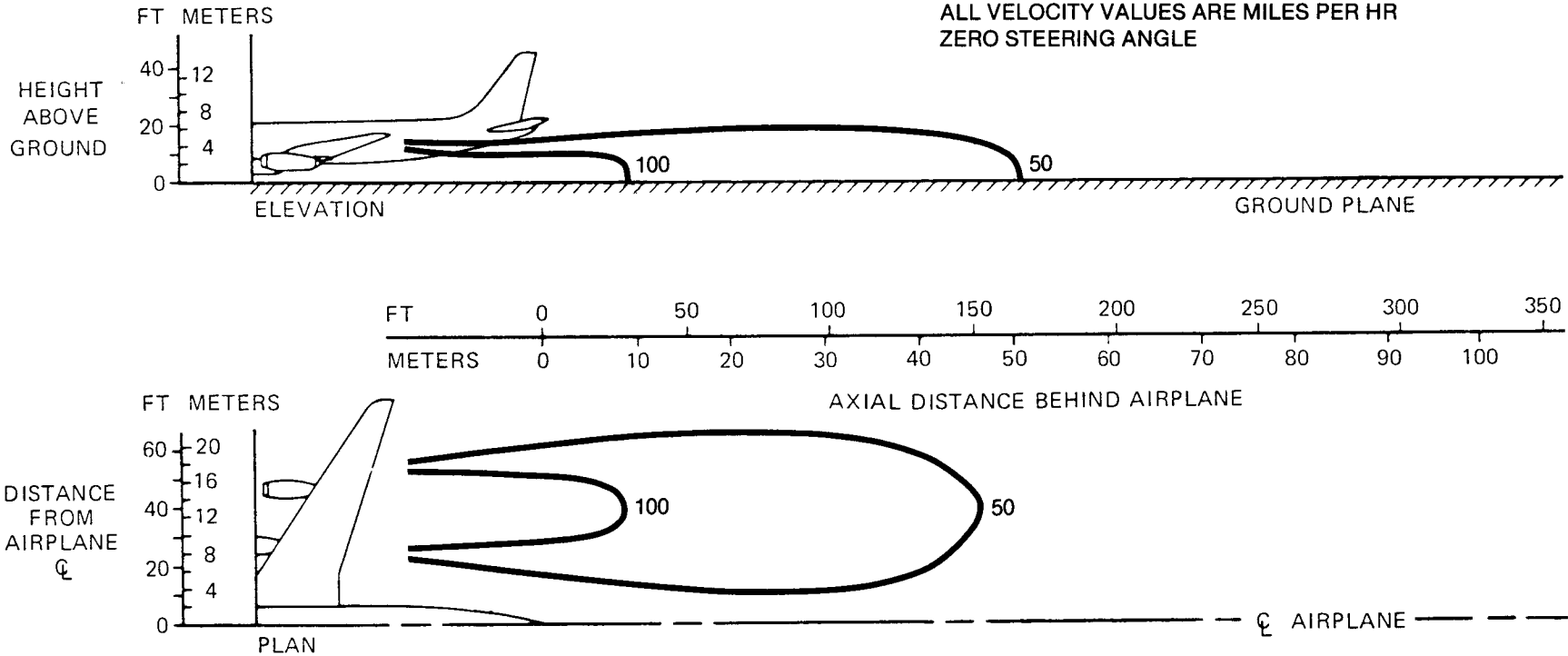

CONVERSION FACTOR: 1 MPH = 1.6 KM PER HR

6.0 OPERATING CONDITIONS

6.1 JET ENGINE EXHAUST VELOCITIES AND TEMPERATURES

6.1.1 JET ENGINE EXHAUST VELOCITY CONTOURS, 4 ENGINE BREAKAWAY POWER

MODEL DC-8, -71, -72, -73

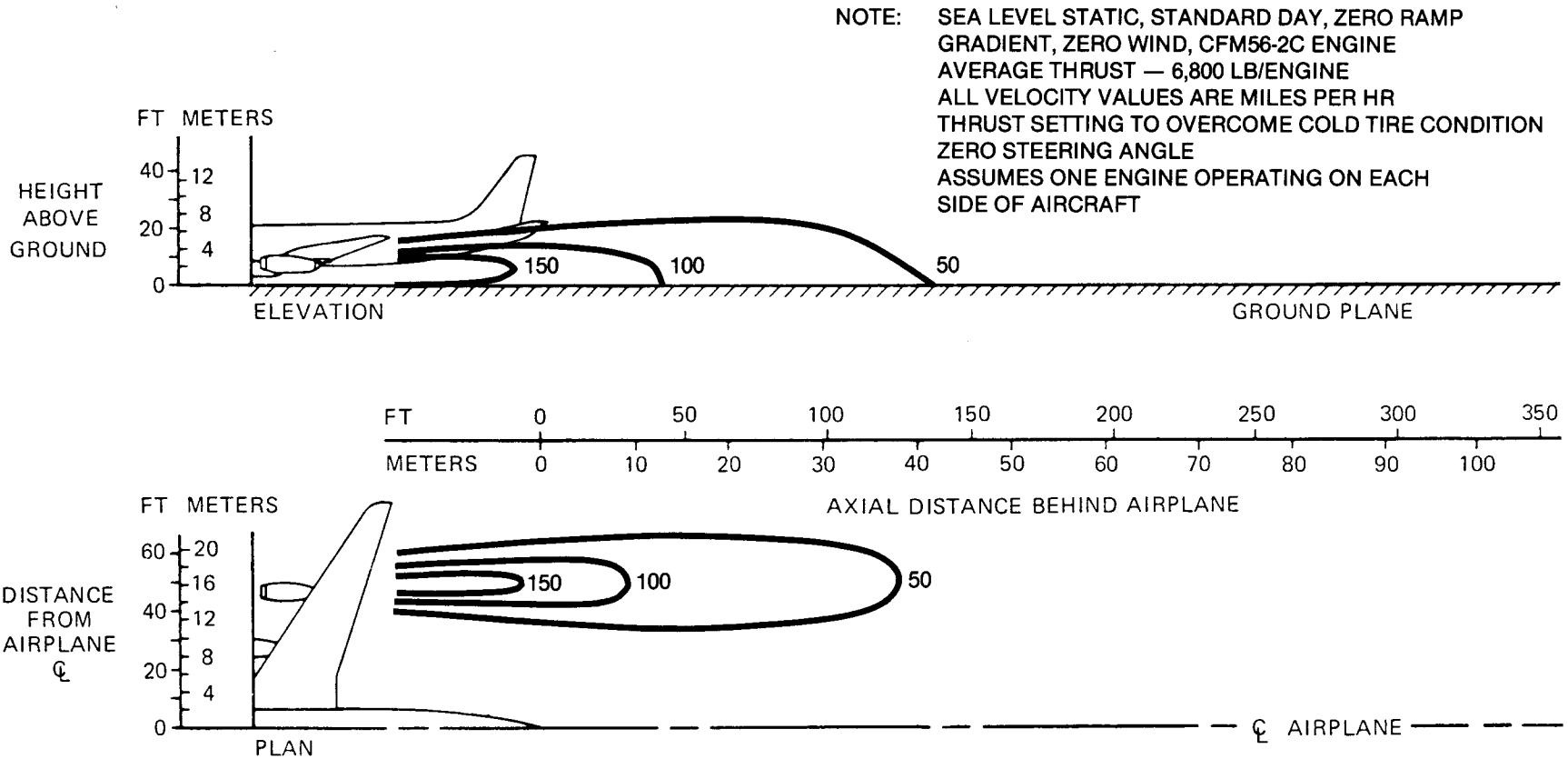

CONVERSION FACTOR: 1 MPH = 1.6 KM PER HR

6.0 OPERATING CONDITIONS

6.1 JET ENGINE EXHAUST VELOCITIES AND TEMPERATURES

6.1.1 JET ENGINE EXHAUST VELOCITY CONTOURS, 2-ENGINE BREAKAWAY POWER

MODEL DC-8, -71, -72, -73

NOTE: SEA LEVEL STATIC, STANDARD DAY, ZERO RAMP GRADIENT, ZERO WIND, JT3D OR RC₁₂ ENGINES
 AVERAGE THRUST — JT3D — 3,400 LB (1,542 KG)
 RC₁₂ — 3,150 LB (1,429 KG)
 ALL TEMPERATURES IN °F
 THRUST SETTING TO OVERCOME COLD TIRE CONDITION
 ZERO STEERING ANGLE

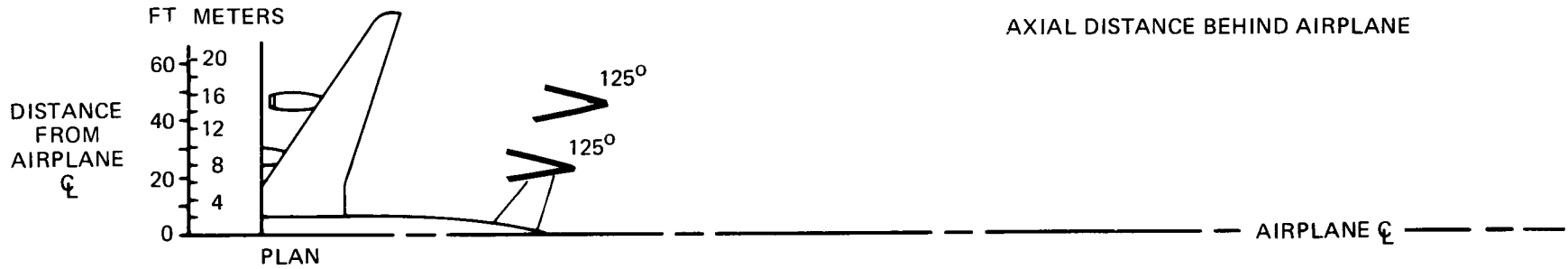
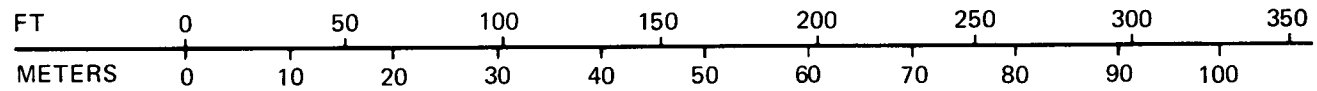
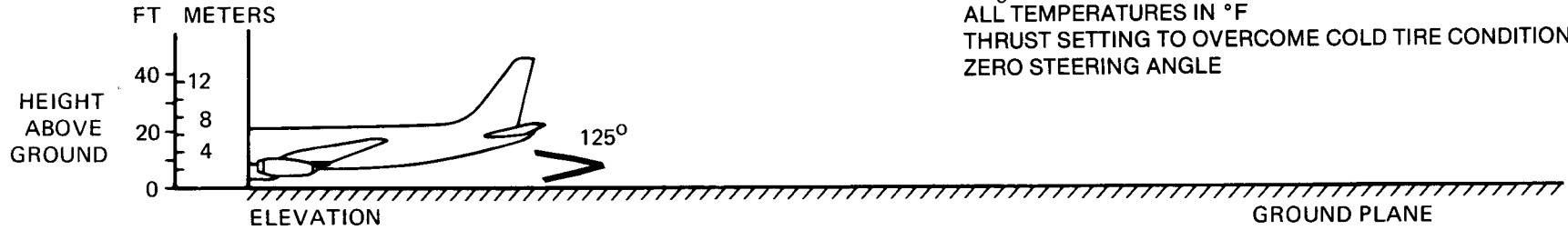

$$\text{CONVERSION: } ^\circ\text{C} = \frac{^\circ\text{F} - 32}{1.8}$$

6.0 OPERATING CONDITIONS

6.1 JET ENGINE EXHAUST VELOCITIES AND TEMPERATURES

6.1.2 JET ENGINE EXHAUST TEMPERATURE CONTOURS, BREAKAWAY POWER

MODEL DC-8, -43, -55, -61, -61F, -62, -62F, -63, -63F

NOTE: SEA LEVEL STATIC, STANDARD DAY, ZERO RAMP GRADIENT, ZERO WIND, CFM56-2C ENGINE
 AVERAGE THRUST — 6,800 LB/ENGINE
 THRUST SETTING TO OVERCOME COLD TIRE CONDITION
 ALL TEMPERATURES IN °F
 ZERO STEERING ANGLE

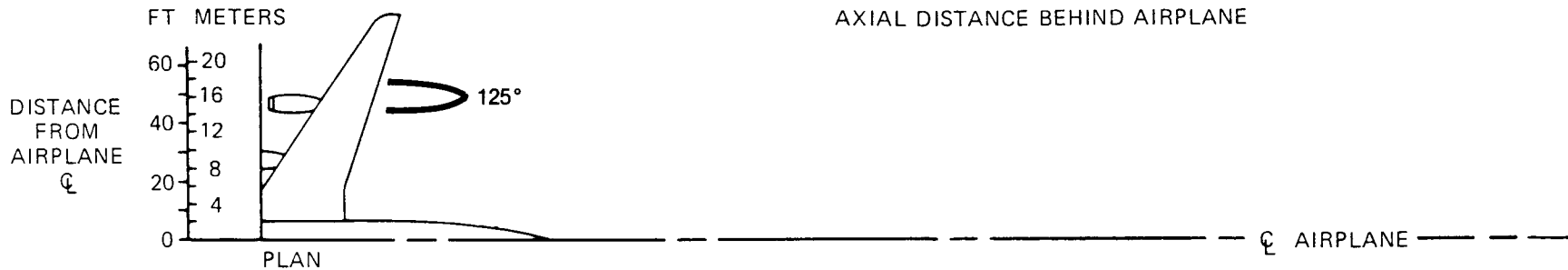
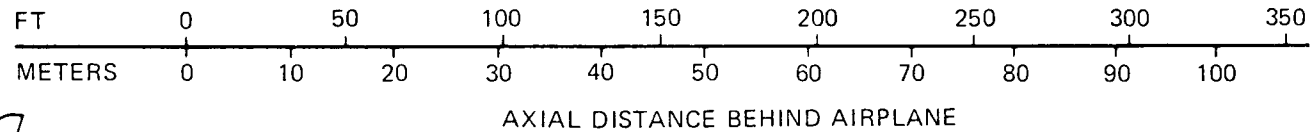
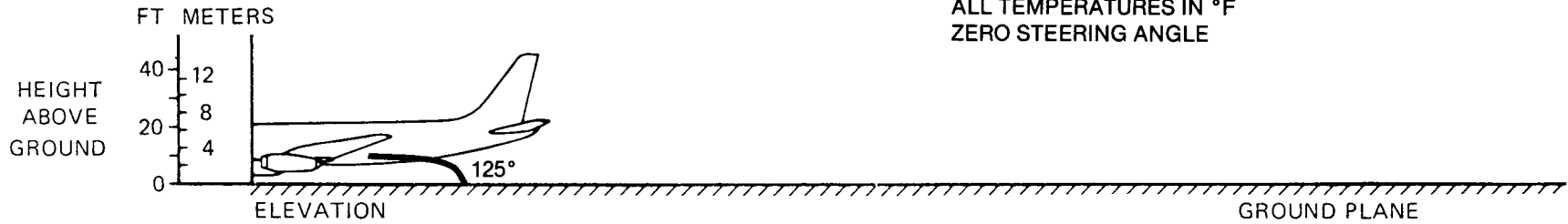

CONVERSION FACTOR: $^{\circ}\text{C} = \frac{^{\circ}\text{F}-32}{1.8}$

6.0 OPERATING CONDITIONS

6.1 JET ENGINE EXHAUST VELOCITIES AND TEMPERATURES

6.1.2 JET ENGINE EXHAUST TEMPERATURE CONTOURS, 2-ENGINE BREAKAWAY POWER

MODEL DC-8, -71, -72, -73

NOTE: SEA LEVEL STATIC, STANDARD DAY, ZERO RAMP
 GRADIENT, ZERO WIND, CFM56-2C ENGINE
 ALL TEMPERATURES IN °F
 AVERAGE THRUST — 3,400 LB/ENGINE
 THRUST SETTING TO OVERCOME COLD TIRE CONDITION
 ZERO STEERING ANGLE

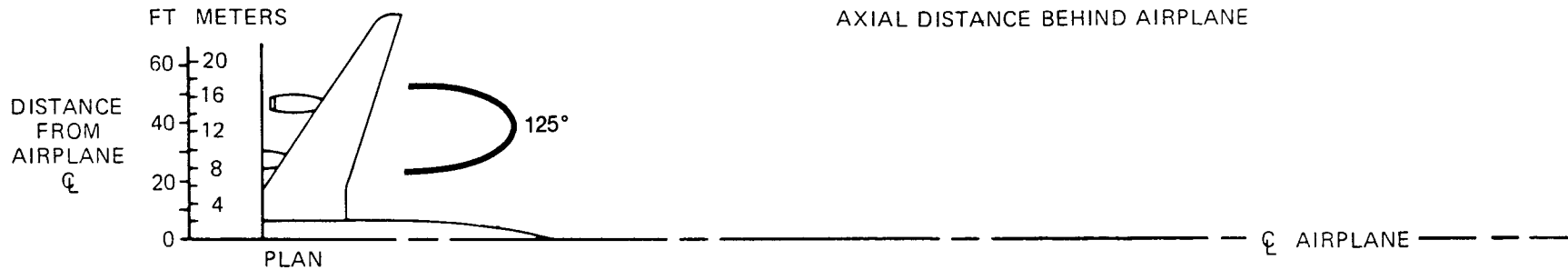
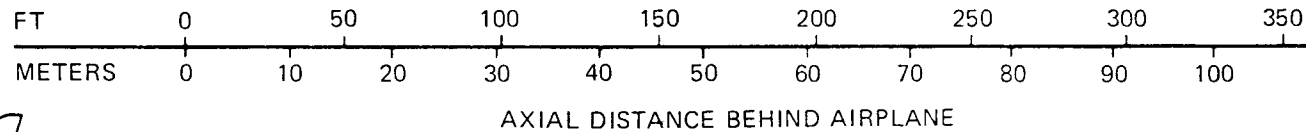
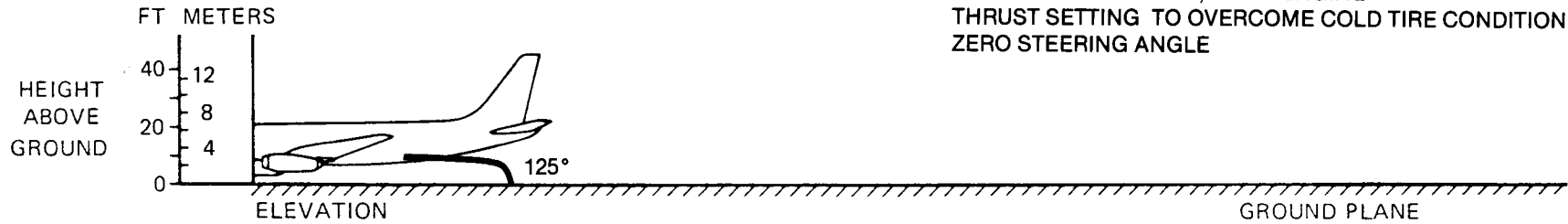

CONVERSION FACTOR: $^{\circ}\text{C} = \frac{^{\circ}\text{F}-32}{1.8}$

6.0 OPERATING CONDITIONS

6.1 JET ENGINE EXHAUST VELOCITIES AND TEMPERATURES

6.1.2 JET ENGINE EXHAUST TEMPERATURE CONTOURS,

4-ENGINE BREAKAWAY POWER

MODEL DC-8, -71, -72, -73

NOTE: SEA LEVEL STATIC, STANDARD DAY, ZERO RAMP GRADIENT, ZERO WIND, JT3D OR RC₀ ENGINES
 AVERAGE THRUST – JT3D – 18,000 LBS (8165 KG)
 RC₀ 12 – 17,300 LBS (7847 KG)
 ALL VELOCITY VALUES ARE MILES PER HR

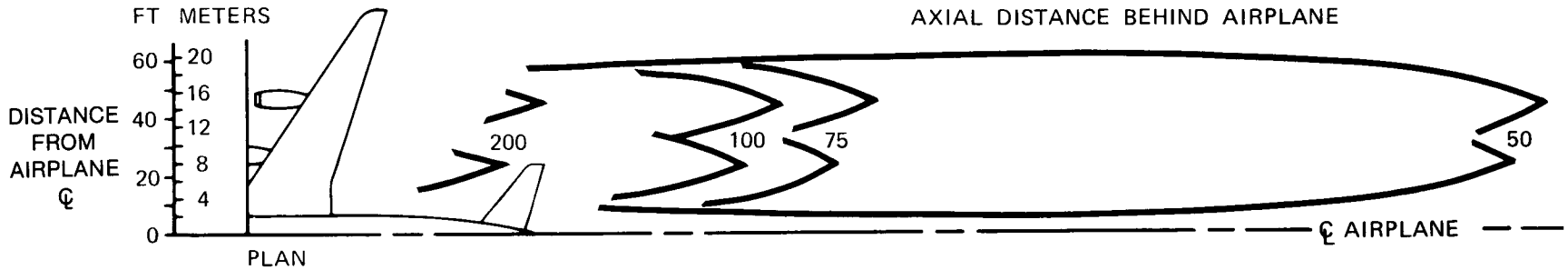
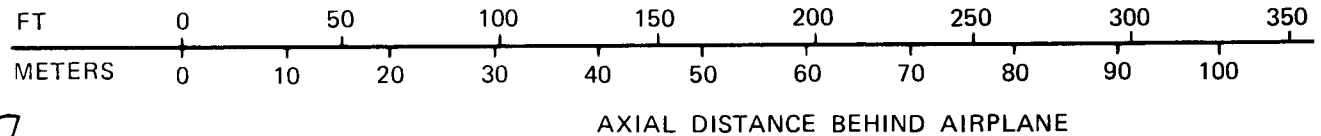
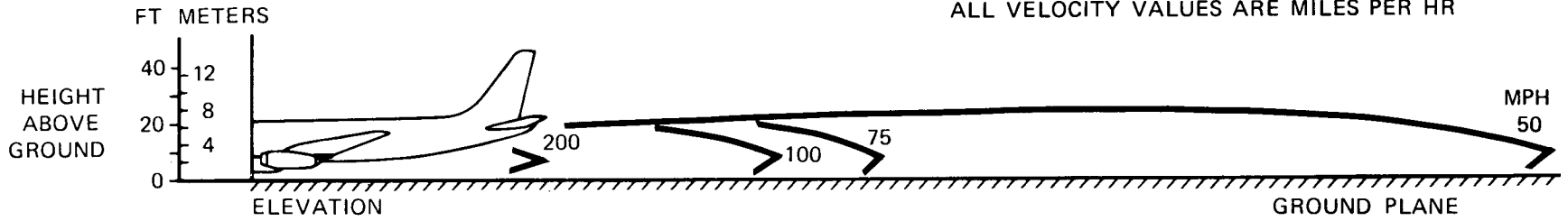

CONVERSION FACTOR: 1 MPH = 1.6 KM PER HR

6.0 OPERATING CONDITIONS

6.1 JET ENGINE EXHAUST VELOCITIES AND TEMPERATURES

6.1.3 JET ENGINE EXHAUST VELOCITY, TAKEOFF POWER

MODEL DC-8, -43, -55, -61, -61F, -62, -62F, -63, -63F

NOTE: SEA LEVEL STATIC, STANDARD DAY, ZERO RAMP GRADIENT, ZERO WIND, CFM56-2C ENGINE AVERAGE THRUST — 22,000 LB/ENGINE ALL VELOCITY VALUES ARE MILES PER HR

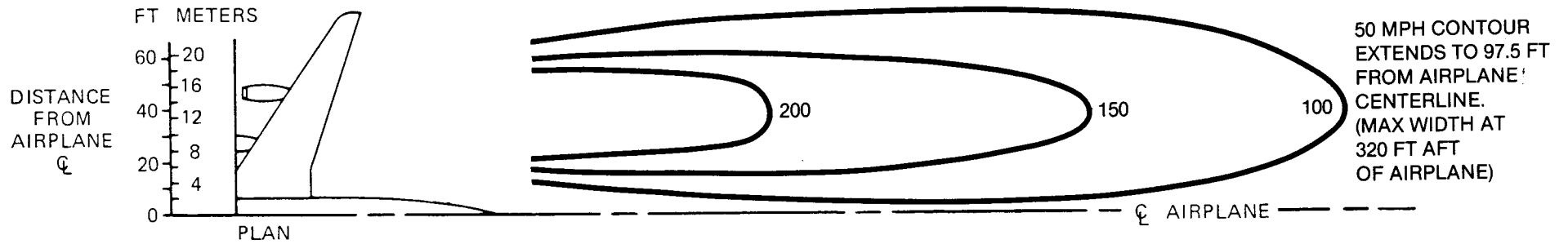
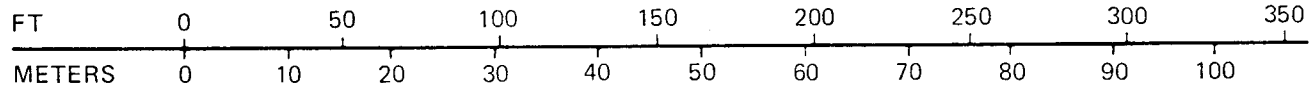
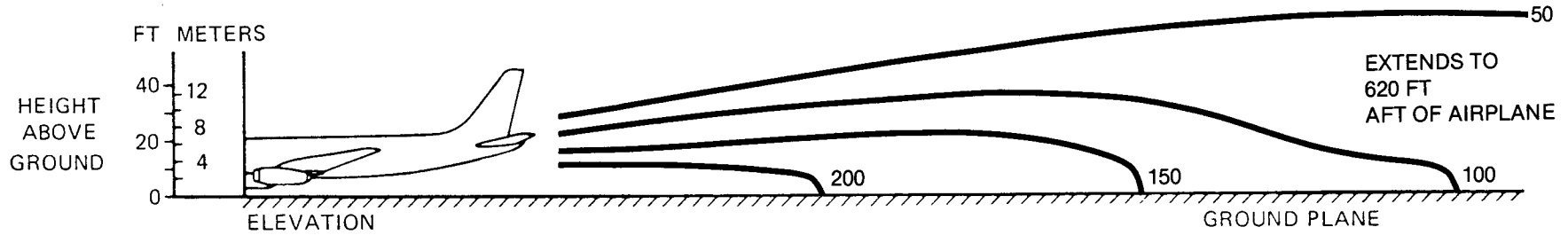

CONVERSION FACTOR: 1 MPH = 1.6 KM PER HR

6.0 OPERATING CONDITIONS

6.1 JET ENGINE EXHAUST VELOCITIES AND TEMPERATURES

6.1.3 JET ENGINE VELOCITY CONTOURS, TAKEOFF POWER MODEL DC-8, -71, -72, -73

NOTE: SEA LEVEL STATIC, STANDARD DAY, ZERO RAMP GRADIENT, ZERO WIND, JT3D OR RC₀ ENGINES
 AVERAGE THRUST – JT3D – 18,000 LBS (8165 KG)
 RC₀ 12 – 17,300 LBS (7847 KG)
 ALL TEMPERATURE ARE °F

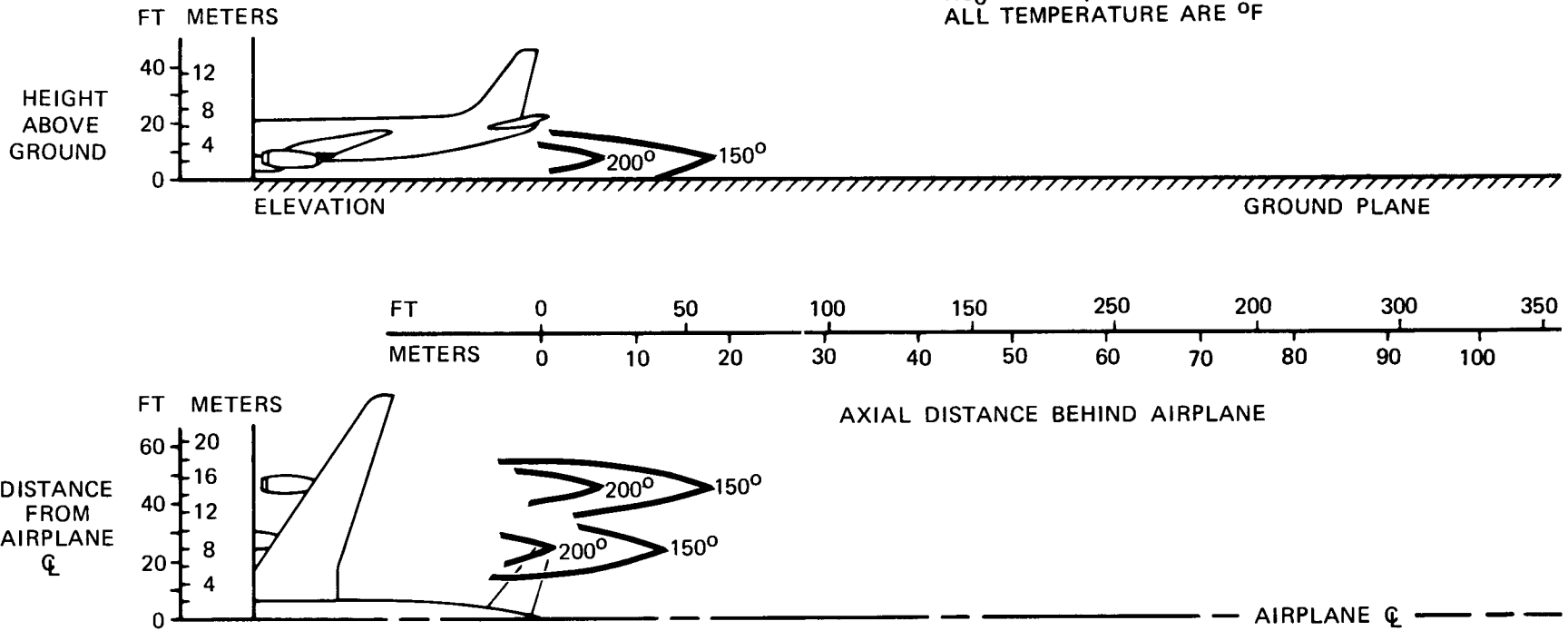

CONVERSION FACTOR: $^{\circ}\text{C} = \frac{^{\circ}\text{F} - 32}{1.8}$

6.0 OPERATING CONDITIONS

6.1 JET ENGINE EXHAUST VELOCITIES AND TEMPERATURES

6.1.4 JET ENGINE EXHAUST TEMPERATURE CONTOURS, TAKEOFF POWER MODEL DC-8, -43, -55, -61, -61F, -62, -62F, -63, -63F

NOTE: SEA LEVEL STATIC, STANDARD DAY, ZERO RAMP GRADIENT, ZERO WIND, CFM56-2C ENGINE AVERAGE THRUST — 22,000 LB/ENGINE ALL TEMPERATURES ARE °F

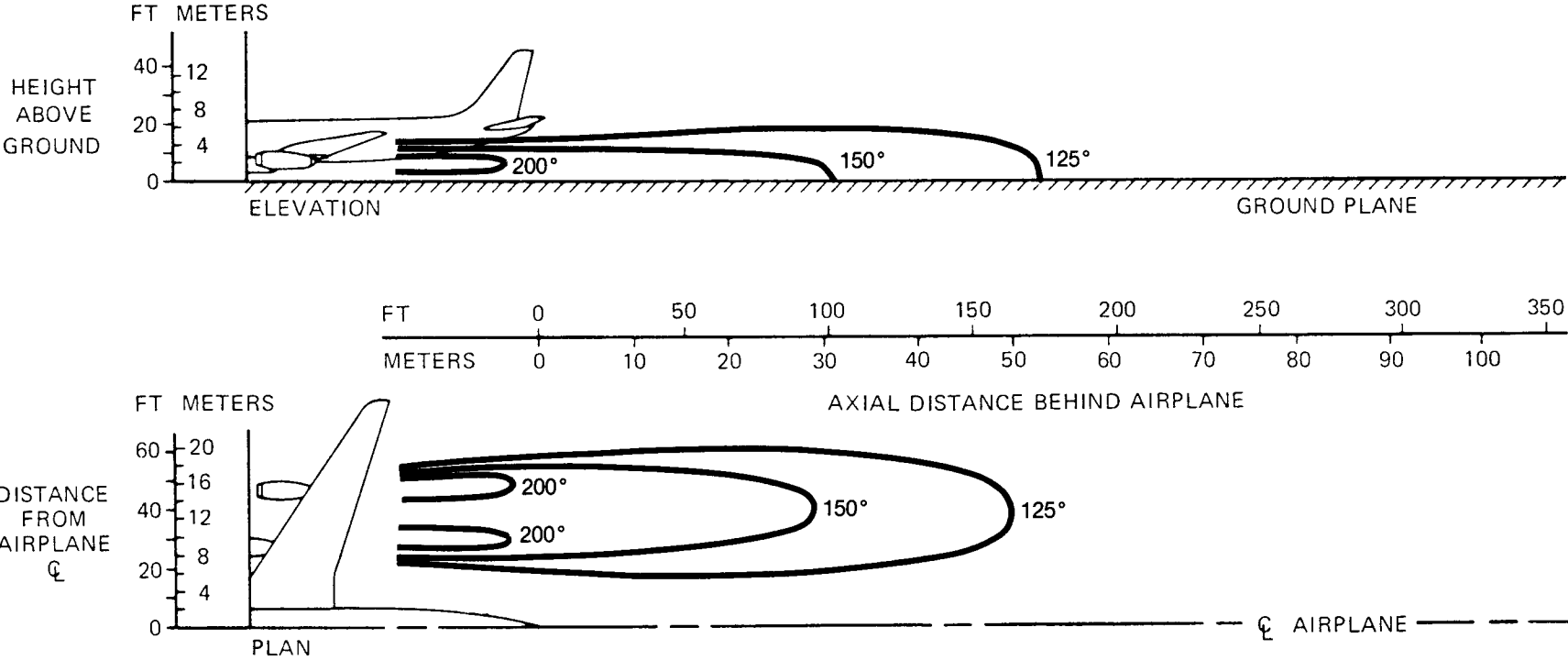

CONVERSION FACTOR: $^{\circ}\text{C} = \frac{^{\circ}\text{F}-32}{1.8}$

6.0 OPERATING CONDITIONS

6.1 JET ENGINE EXHAUST VELOCITIES AND TEMPERATURES

6.1.4 JET ENGINE EXHAUST TEMPERATURE CONTOURS, TAKEOFF POWER MODEL DC-8, -71, -72, -73

NOTE: SEA LEVEL STATIC, STANDARD DAY, ZERO RAMP GRADIENT, JT3D OR RC₀ ENGINES AVERAGE THRUST, JT3D – 900 LBS (408 KG) RC₀ 12 – 760 LBS (345 KG) ALL VELOCITY VALUES ARE MILES PER HR

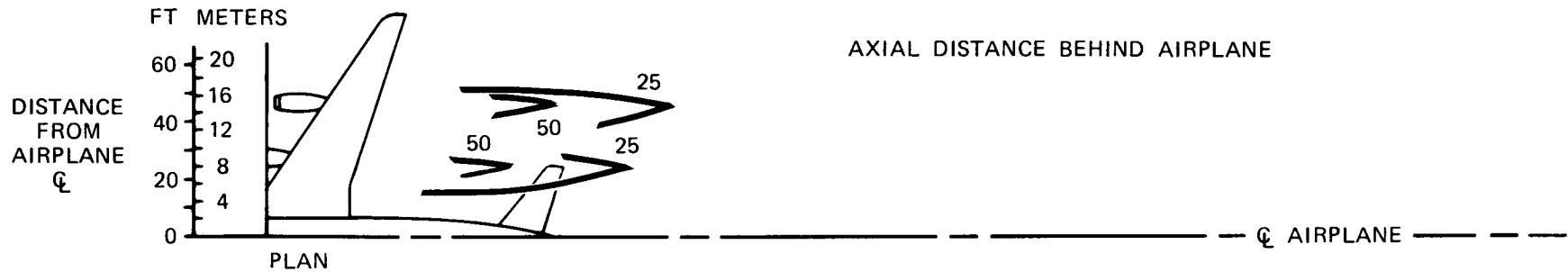
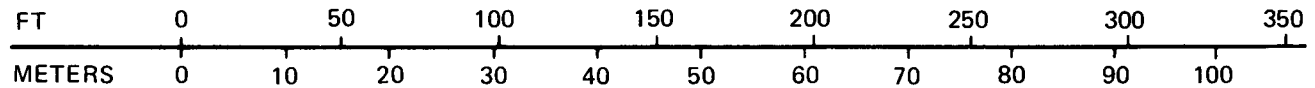
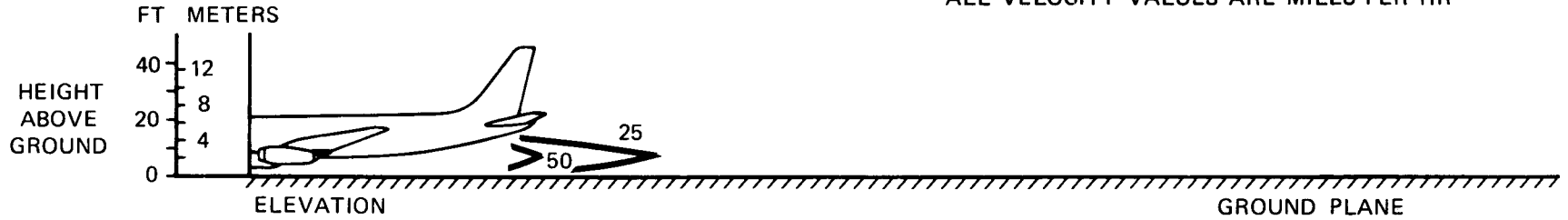

CONVERSION FACTOR: 1 MPH = 1.6 KM PER HR

6.0 OPERATING CONDITIONS

6.1 JET ENGINE EXHAUST VELOCITIES AND TEMPERATURES

6.1.5 JET ENGINE EXHAUST VELOCITY CONTOURS, IDLE POWER MODEL DC-8, -43, -55, -61, -61F, -62, -62F, -63, -63F

NOTE: SEA LEVEL STATIC, STANDARD DAY, ZERO RAMP GRADIENT, ZERO WIND, CFM56-2C ENGINE AVERAGE THRUST — 1,330 LB/ENGINE ALL VELOCITY VALUES ARE IN MILES PER HR

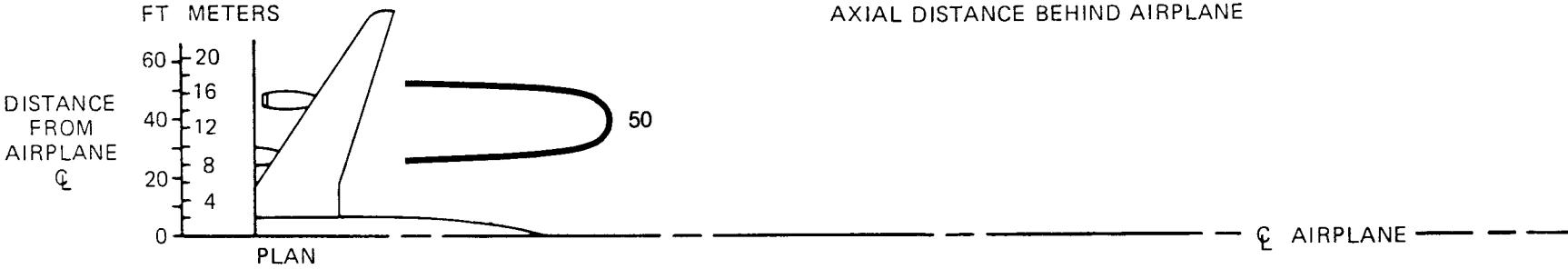
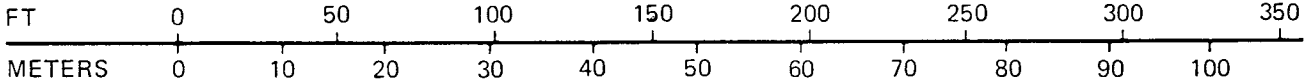
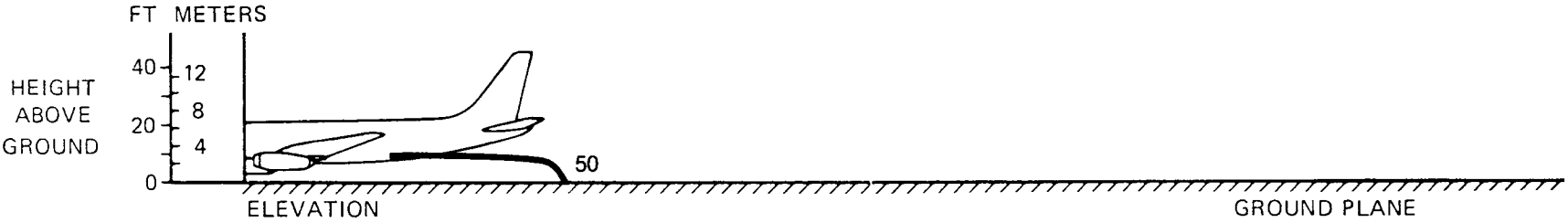

CONVERSION FACTOR: 1 MPH = 1.6 KM PER HR

6.0 OPERATING CONDITIONS

6.1 JET ENGINE EXHAUST VELOCITIES AND TEMPERATURES

6.1.5 JET ENGINE EXHAUST VELOCITY CONTOURS, IDLE POWER MODEL DC-8, -71, -72, -73

NOTE: SEA LEVEL STATIC, STANDARD DAY, ZERO RAMP GRADIENT, ZERO WIND, JT3D OR RC₀ ENGINES
 ALL TEMPERATURES IN °F AVERAGE THRUST
 JT3D @ 900 LBS (408 KG) RC₀ 12 – 760 LBS (345 KG)

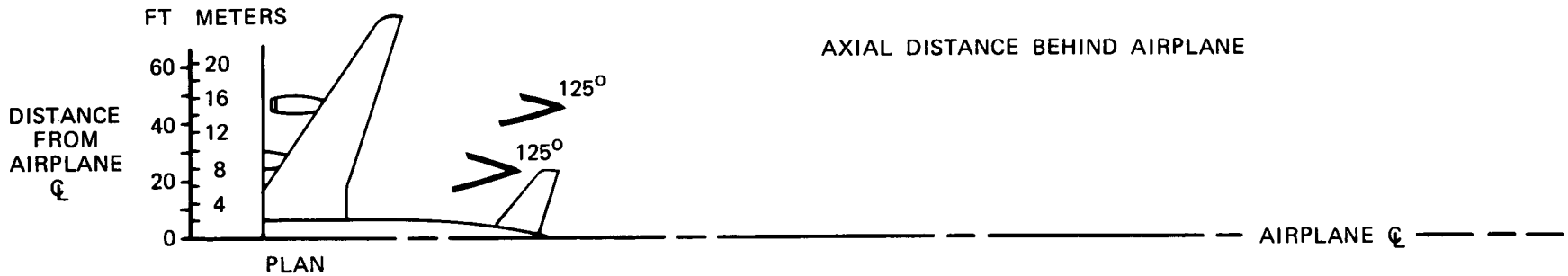
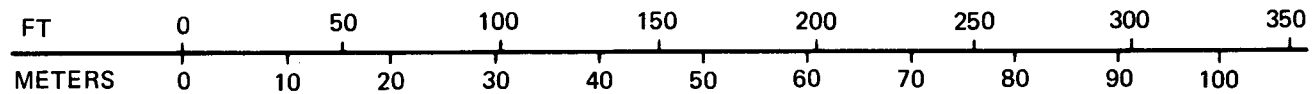
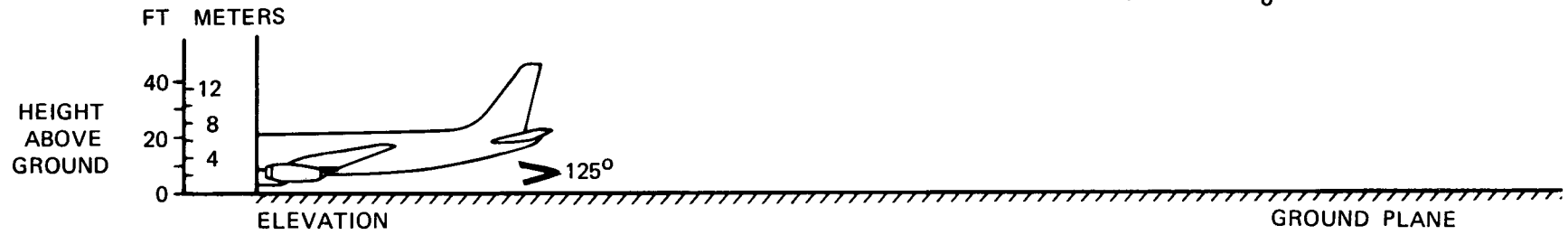

CONVERSION: $^{\circ}\text{C} = \frac{^{\circ}\text{F} - 32}{1.8}$

6.0 OPERATING CONDITIONS

6.1 JET ENGINE EXHAUST VELOCITIES AND TEMPERATURES

6.1.6 JET ENGINE EXHAUST TEMPERATURE CONTOURS, IDLE POWER

MODEL DC-8, -43, -55, -61, -61F, -62, -62F, -63, -63F

NOTE: SEA LEVEL STATIC, STANDARD DAY, ZERO RAMP GRADIENT, ZERO WIND, CFM56-2C ENGINE
 ALL TEMPERATURES IN °F
 AVERAGE THRUST — 1,330 LB/ENGINE

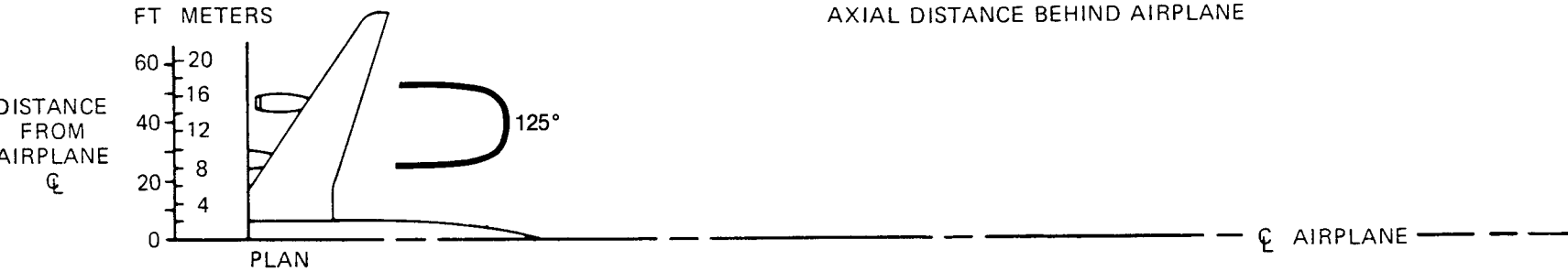
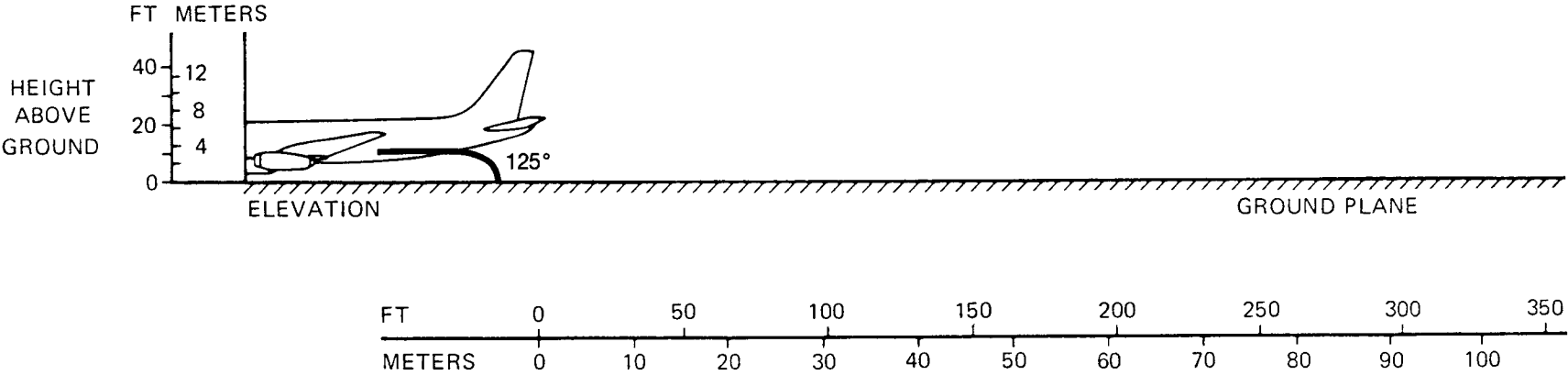

6.0 OPERATING CONDITIONS

6.1 JET ENGINE EXHAUST VELOCITIES AND TEMPERATURES

6.1.6 JET ENGINE EXHAUST TEMPERATURE CONTOURS, IDLE POWER
 MODEL DC-8, -71, -72, -73

CONVERSION FACTOR: $^{\circ}\text{C} = \frac{^{\circ}\text{F}-32}{1.8}$

6.2 Airport and Community Noise

Aircraft noise is of major concern to the airport and community planner. The airport is a major element in the community's transportation system and, as such, is vital to its growth. However, the airport must also be a good neighbor, and this can be accomplished only with proper planning. Since aircraft noise extends beyond the boundaries of the airport, it is vital to consider the impact on surrounding communities. Many means have been devised to provide the planner with a tool to estimate the impact of airport operations. Too often they oversimplify noise to the point where the results become erroneous. Noise is not a simple subject; therefore, there are no simple answers.

The cumulative noise contour is an effective tool. However, care must be exercised to ensure that the contours, used correctly, estimate the noise resulting from aircraft operations conducted at an airport.

The size and shape of the single-event contours, which are inputs into the cumulative noise contours, are dependent upon numerous factors. They include:

1. Operational Factors
 - a. *Aircraft Weight* — Aircraft weight is dependent on distance to be traveled, en route winds, payload, and anticipated aircraft delay upon reaching the destination.
 - b. *Engine Power Settings* — The rates of ascent and descent and the noise levels emitted at the source are influenced by the power setting used.
 - c. *Airport Altitude* — Higher airport altitudes will affect engine performance and thus can influence noise.

(Continued)

2. Atmospheric Conditions — Sound Propagation

- a. *Wind* — With stronger headwinds, the aircraft can take off and climb more rapidly relative to the ground. Also, winds can influence the distribution of noise in surrounding communities.
 - b. *Temperature and Relative Humidity* — The absorption of noise in the atmosphere along the transmission path between the aircraft and the ground observer varies with both temperature and relative humidity.
3. Surface Condition — Shielding, Extra Ground Attenuation (EGA)
- a. *Terrain* — If the ground slopes down after takeoff or up before landing, noise will be reduced since the aircraft will be at a higher altitude above ground. Additionally, hills, shrubs, trees, and large buildings can act as sound buffers.

All of these factors can alter the shape and size of the contours appreciably. To demonstrate the effect of some of these factors, estimated noise level contours for two different operating conditions are shown below. These contours reflect a given noise level upon a ground level plane at runway elevation.

Condition 1

Landing:	Takeoff:
Maximum Design Landing Weight	Maximum Design Takeoff Weight
10-knot Headwind	Zero Wind
3° Approach	84°F
84°F	Humidity 15%
Humidity 15%	

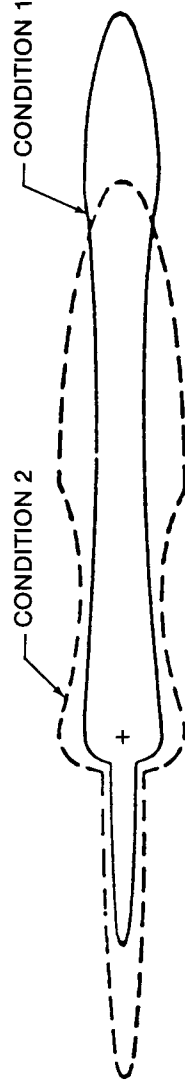

Condition 2

Landing:

85% of Maximum Design
Landing Weight
10-knot Headwind
3° Approach
59°F
Humidity 70%

Takeoff:

80% of Maximum Design
Takeoff Weight
10-knot Headwind
59°F
Humidity 70%

As indicated from these data, the contour size varies substantially with operating and atmospheric conditions. Most aircraft operations are, of course, conducted at less than maximum gross weights because average flight distances are much shorter than maximum aircraft range capability and average load factors are less than 100 percent. Therefore, in developing cumulative contours for planning purposes, it is recommended that the airlines serving a particular city be contacted to provide operational information.

In addition, there are no universally accepted methods for developing aircraft noise contours or for relating the acceptability of specific noise zones to specific land uses. It is therefore expected that noise contour data for particular aircraft and the impact assessment methodology will be changing. To ensure that current available information of this type is used in any planning study, it is recommended that it be obtained directly from the Office of Environmental Quality in the Federal Aviation Administration in Washington, D.C.

It should be noted that the contours shown herein are only for illustrating the impact of operating and atmospheric conditions and do not represent the single-event contour of the family of aircraft described in this document. It is expected that the cumulative contours will be developed as required by planners using the data and methodology applicable to their specific study.

7.0 PAVEMENT DATA

7.1 General Information

A brief description of the pavement charts that follow will help in their use for airport planning. Each airplane configuration is depicted with a minimum range of four loads imposed on the main landing gear to aid in interpolation between the discrete values shown. All curves for any single chart represent data based on rated loads and tire pressures considered normal and acceptable by current aircraft tire manufacturer's standards.

Pages 180 and 181 present basic data on the landing gear footprint configuration, maximum design taxi loads, and tire sizes and pressures.

Maximum pavement loads for certain critical conditions at the tire-to-ground interface are shown on Page 182.

Pavement requirements for commercial airplanes are customarily derived from the static analysis of loads imposed on the main landing gear struts. The charts on Pages 183 through 191 are provided in order to determine these loads throughout the stability limits of the airplane at rest on the pavement. These main landing gear loads are used as the point of entry to the pavement design charts, interpolating load values where necessary.

The flexible pavement design curves (Section 7.5) are based on procedures set forth in Instruction Report No. S-77-1, "Procedures for Development of CBR Design Curves," dated June 1977, and as modified according to the methods described in ICAO Aerodrome Design Manual, Part 3, Pavements, 2nd Edition, 1983, Section 1.1 (The ACN-PCN Method), and utilizing the alpha factors approved by ICAO in October 2007. Instruction Report No. S-77-1 was prepared by the U.S. Army Corps of Engineers Waterways Experiment Station, Soils and Pavements Laboratory, Vicksburg, Mississippi. The line showing 10,000 coverages is used to calculate Aircraft Classification Number (ACN).

Rigid pavement design curves (Section 7.7) have been prepared with the Westergaard equation in general accordance with the procedures outlined in the Design of Concrete Airport Pavement (1955 edition) by Robert G. Packard, published by the American Concrete Pavement Association, 3800 North Wilke Road, Arlington Heights, Illinois 60004-1268. These curves are modified to the format described in the Portland Cement Association publication XP6705-2, Computer Program for Airport Pavement Design (Program PDILB), 1968, by Robert G. Packard.

The following procedure is used to develop rigid pavement design curves such as those shown on Pages 203 through 211.

1. Having established the scale for pavement thickness to the left and the scale for allowable working stress to the right, an arbitrary line is drawn representing the main landing gear maximum weight to be shown.
2. All values of the subgrade modulus (k-values) are then plotted.
3. Additional load lines for the incremental values of weight on the main landing gear are then established on the basis of the curve for $k = 300$, already established.

All LCN curves where shown have been plotted from data in the International Civil Aviation Organization (ICAO) Document 7290-AN/865/2, Aerodrome Manual, Part 2, “Aerodrome Physical Characteristics,” 2nd Edition, 1965.

On the same charts showing LCN versus equivalent single wheel load, there are load plots showing equivalent single wheel load versus pavement thickness for flexible pavements and versus radius of relative stiffness for rigid pavements.

Procedures and curves provided in the ICAO Aerodrome Manual — Part 2, Chapter 4 are used to determine equivalent single wheel loads for use in making LCN conversion of rigid pavement requirements.

Note: Pavement requirements are presented for loads, tires and tire pressures presently certified for commercial usage. All curves represent data at a constant specified tire pressure.

The ACN/PCN system as referenced in Amendment 35 to ICAO Annex 14, “Aerodromes,” 7th Edition, June 1976, provides a standardized international airplane/pavement rating system replacing the various S, T, TT, LCN, AUC, ISWL, etc., rating systems used throughout the world. ACN is the Aircraft Classification Number and PCN is the corresponding Pavement Classification Number. An aircraft having an ACN equal to or less than the PCN can operate without restriction on the pavement. Numerically, the ACN is two times the derived single wheel load expressed in thousands of kilograms where the derived single wheel load is defined as the load on a single tire inflated to 1.25 MPa (181 psi) that would have the same pavement requirements as the aircraft. Computationally, the ACN/PCN system uses a PCA program PDILB for rigid pavements and S-77-1 for flexible pavements to calculate ACN values. The method of pavement evaluation is left up to the airport with the results of their evaluation presented as follows:

PCN -	PAVEMENT TYPE	SUBGRADE CATEGORY	TIREPRESSURE CATEGORY	EVALUATION METHOD
R	Rigid	A - High	W - No Limit	T - Technical
F	Flexible	B - Medium	X - To 1.75 MPa (254 psi)	U - Using aircraft
		C - Low	Y - To 1.25 MPa (181 psi)	
		D - Ultra Low	Z - To 0.5 MPa (73 psi)	

Page 226 shows the aircraft ACN values for flexible pavements. The four subgrade categories are:

- A - High Strength - CBR 15
- B - Medium Strength - CBR 10
- C - Low Strength - CBR 6
- D - Ultra Low Strength - CBR 3

Page 227 shows the aircraft ACN values for rigid pavements. The four subgrade categories are:

- A - High Strength - Subgrade k = 150 MN/m³ (550 pci)
- B - Medium Strength - Subgrade k = 80 MN/m³ (300 pci)
- C - Low Strength - Subgrade k = 40 MN/m³ (150 pci)
- D - Ultra Low Strength - Subgrade k = 20 MN/m³ (75 pci)

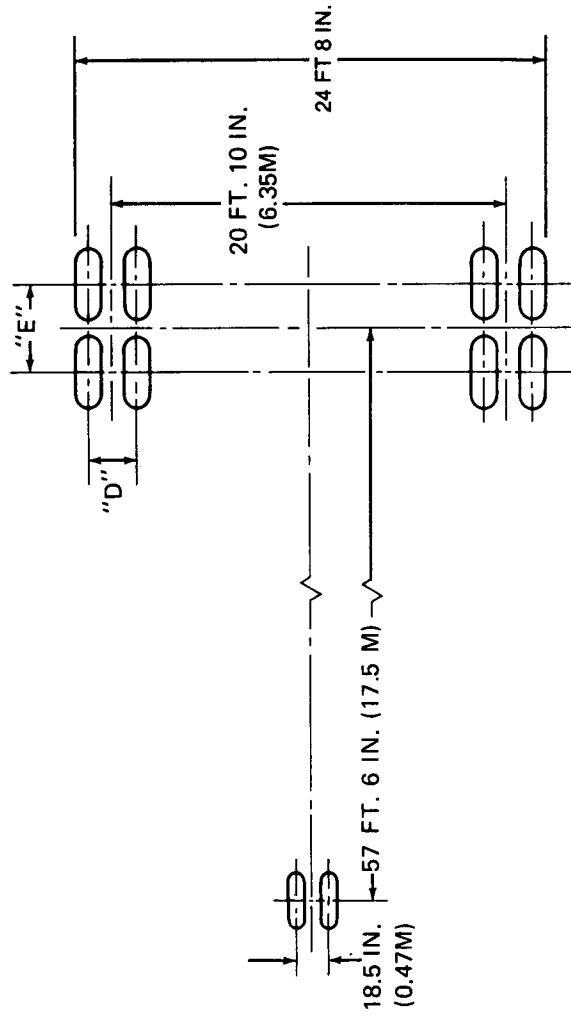

MODEL DC-8			
	-43	-55	-55F
MAXIMUM DESIGN TAXI WEIGHT	318,000 LB 144,245 KG	328,000 LB 148,781 KG	328,000 LB 148,781 KG
PERCENT OF WEIGHT ON MAIN GEAR	SEE GRAPH 7.4		
NOSE TIRE SIZE	34 x 11 TYPE VII	34 x 11 TYPE VII	34 x 11 TYPE VII
NOSE TIRE PRESSURE	162 PSI 11.4 KG/CM ²	171 PSI 12.0 KG/CM ²	171 PSI 12.0 KG/CM ²
MAIN GEAR TIRE SIZE	44 x 16 TYPE VII	44 x 16 TYPE VII	44 x 16 TYPE VII
MAIN GEAR TIRE PRESSURE	177 PSI 12.5 KG/CM ²	186 PSI 13.1 KG/CM ²	186 PSI 13.1 KG/CM ²
MAIN GEAR TIRE SPACING	IN. CM	IN. CM	IN. CM
"D" DIM.	30 76.2	30 76.2	30 76.2
"E" DIM.	55 139.7	55 139.7	55 139.7

7.2 FOOTPRINT

MODEL DC-8-43, -55, -55F

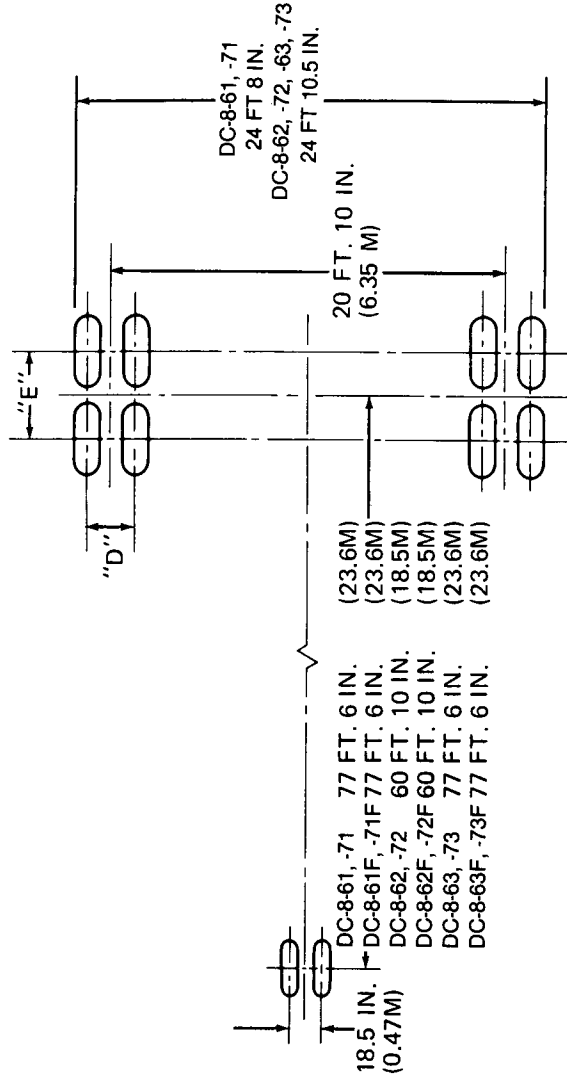

MODEL DC-8						
	-61/-71	-61F/-71F	-62/-72	-62F/-72F	-63/-73	-63F/-73F
MAXIMUM DESIGN TAXI WEIGHT	328,000 LB 148,781 KG	331,000 LB 150,142 KG	353,000 LB 160,121 KG	353,000 LB 160,121 KG	358,000 LB 162,389 KG	358,000 LB 162,389 KG
PERCENT OF WEIGHT ON MAIN GEAR						
NOSE TIRE SIZE	34 x 11 TYPE VII	34 x 11 TYPE VII	34 x 11 TYPE VII	34 x 11 TYPE VII	34 x 11 TYPE VII	34 x 11 TYPE VII
NOSE TIRE PRESSURE	118 PSI 8.3 KG/CM ²	119 PSI 8.4 KG/CM ²	174 PSI 12.2 KG/CM ²	174 PSI 12.2 KG/CM ²	147 PSI 10.3 KG/CM ²	147 PSI 10.3 KG/CM ²
MAIN GEAR TIRE SIZE	44 x 16 TYPE VII	44 x 16 TYPE VII	44.5 x 16.5-18 TYPE VII	44.5 x 16.5-18 TYPE VII	44.5 x 16.5-18 TYPE VII	44.5 x 16.5-18 TYPE VII
MAIN GEAR TIRE PRESSURE	188 PSI 13.2 KG/CM ²	190 PSI 13.4 KG/CM ²	191 PSI 13.4 KG/CM ²	191 PSI 13.4 KG/CM ²	196 PSI 13.8 KG/CM ²	196 PSI 13.8 KG/CM ²
MAIN GEAR TIRE SPACING	IN.	IN.	IN.	IN.	IN.	IN.
"D" DIM	30	30	32	32	32	32
"E" DIM	55	55	55	55	55	55

SEE GRAPH 7.4

7.2 FOOTPRINT

MODEL DC-8-61, -61F, -62, -62F, -63, -63F, -71, -71F, -72, -72F, -73, -73F

LEGEND: V_{NG} = MAXIMUM VERTICAL NOSE GEAR GROUND LOAD AT MOST FORWARD C.G.

V_{MG} = MAXIMUM VERTICAL MAIN GEAR GROUND LOAD AT MOST AFT C.G.

H = MAXIMUM HORIZONTAL GROUND LOAD FROM BRAKING

NOTE: ALL LOADS CALCULATED USING
AIRPLANE MAXIMUM DESIGN TAXI WEIGHT

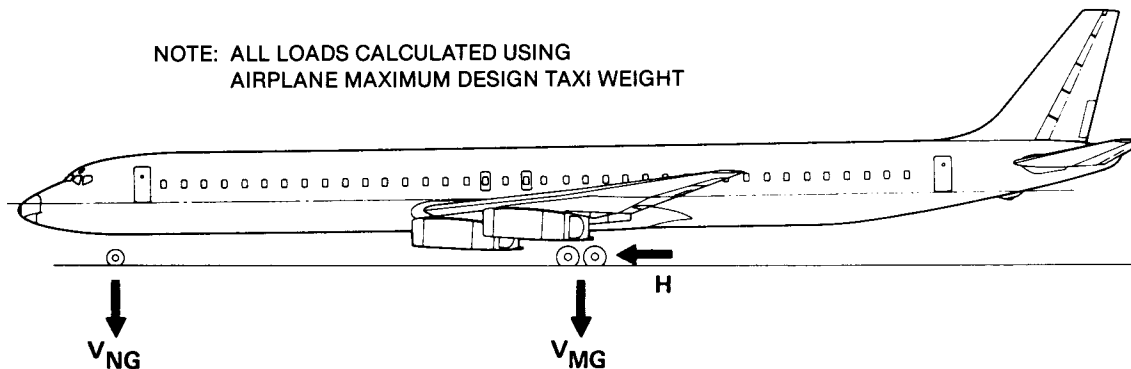

MODEL DC-8	MAXIMUM DESIGN TAXI WEIGHT	V_{NG} , FORWARD C.G.				V_{MG} PER STRUT (2), AFT C.G.				H PER STRUT (2)	
		STATIC		STEADY BRAKING*		STATIC		STEADY BRAKING*		INSTANTANEOUS BRAKING COEFFICIENT OF FRICTION 0.8	
		LB	KG	LB	KG	LB	KG	LB	KG	LB	KG
-43	318,000	32,541	14,761	50,290	22,812	148,029	67,146	139,156	63,121	103,536	46,964
-55	328,000	34,023	15,433	52,331	23,737	155,144	70,373	146,076	66,260	108,571	49,248
-55F	328,000	36,385	16,504	54,692	24,808	155,308	70,448	146,123	66,281	108,605	49,263
-61/-71	328,000	27,431	12,443	41,342	18,753	157,604	71,489	150,573	68,300	113,609	51,533
-61F/-71F	331,000	25,619	11,621	39,770	18,040	158,879	72,068	150,580	68,303	113,661	51,557
-62/-72	353,000	35,219	15,975	72,700	32,977	164,772	74,741	155,600	70,580	116,263	52,737
-62F/-72F	353,000	36,140	16,393	73,514	33,346	167,795	76,112	158,667	71,971	112,319	50,940
-63/-73	358,000	30,448	13,828	64,535	29,273	172,070	78,051	161,954	73,462	121,865	55,278
-63F/-73F	358,000	30,659	13,907	64,723	29,358	172,070	78,051	161,954	73,462	121,865	55,278

*10 FT/SEC² DECELERATION

7.3 MAXIMUM PAVEMENT LOADS MODEL DC-8-ALL SERIES

NOTE: UNSHADED AREAS REPRESENT OPERATIONAL LIMITS

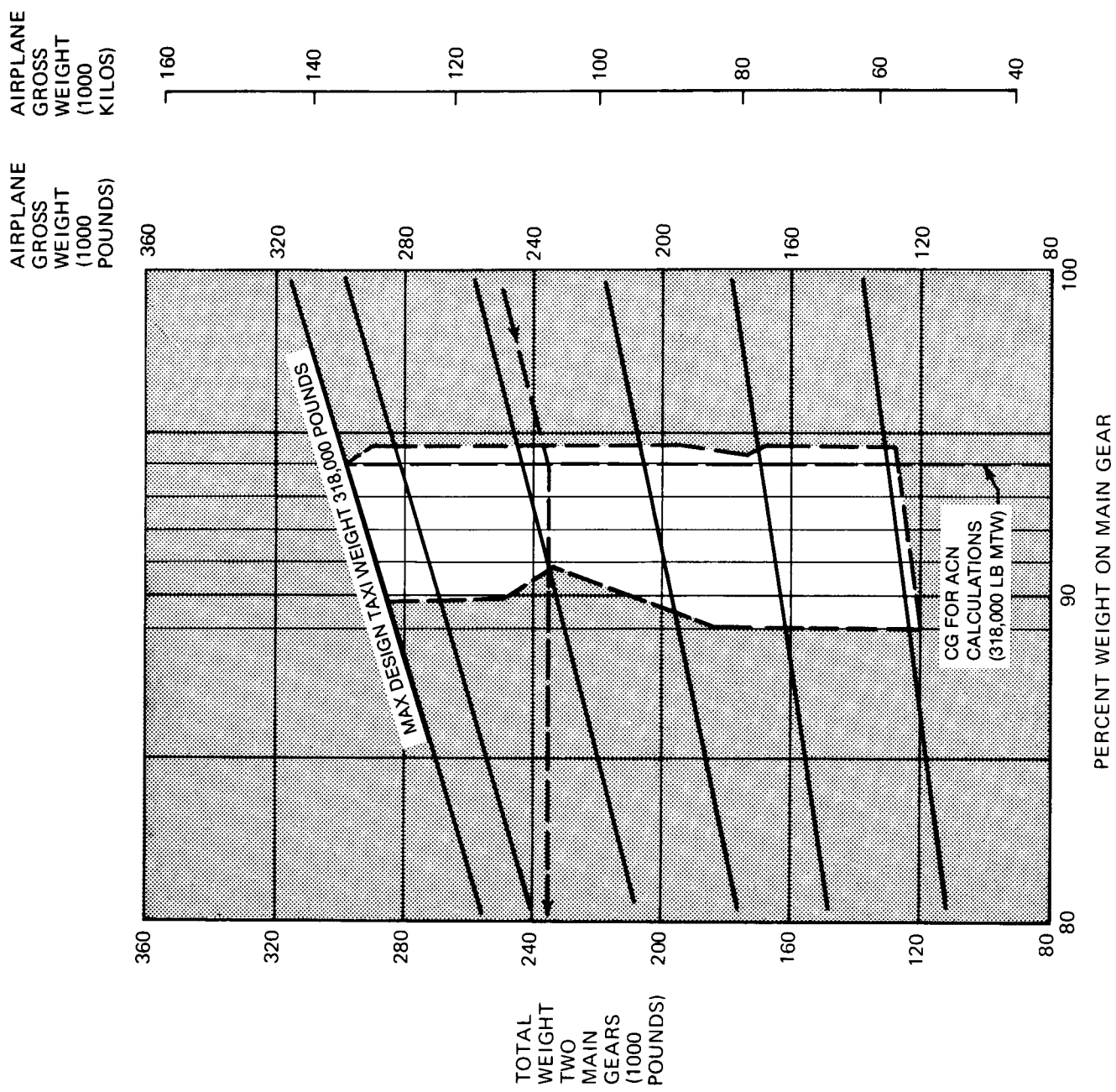

7.4 LANDING GEAR LOADING ON PAVEMENT MODEL DC-8-43

NOTE: UNSHADED AREAS REPRESENT OPERATIONAL LIMITS

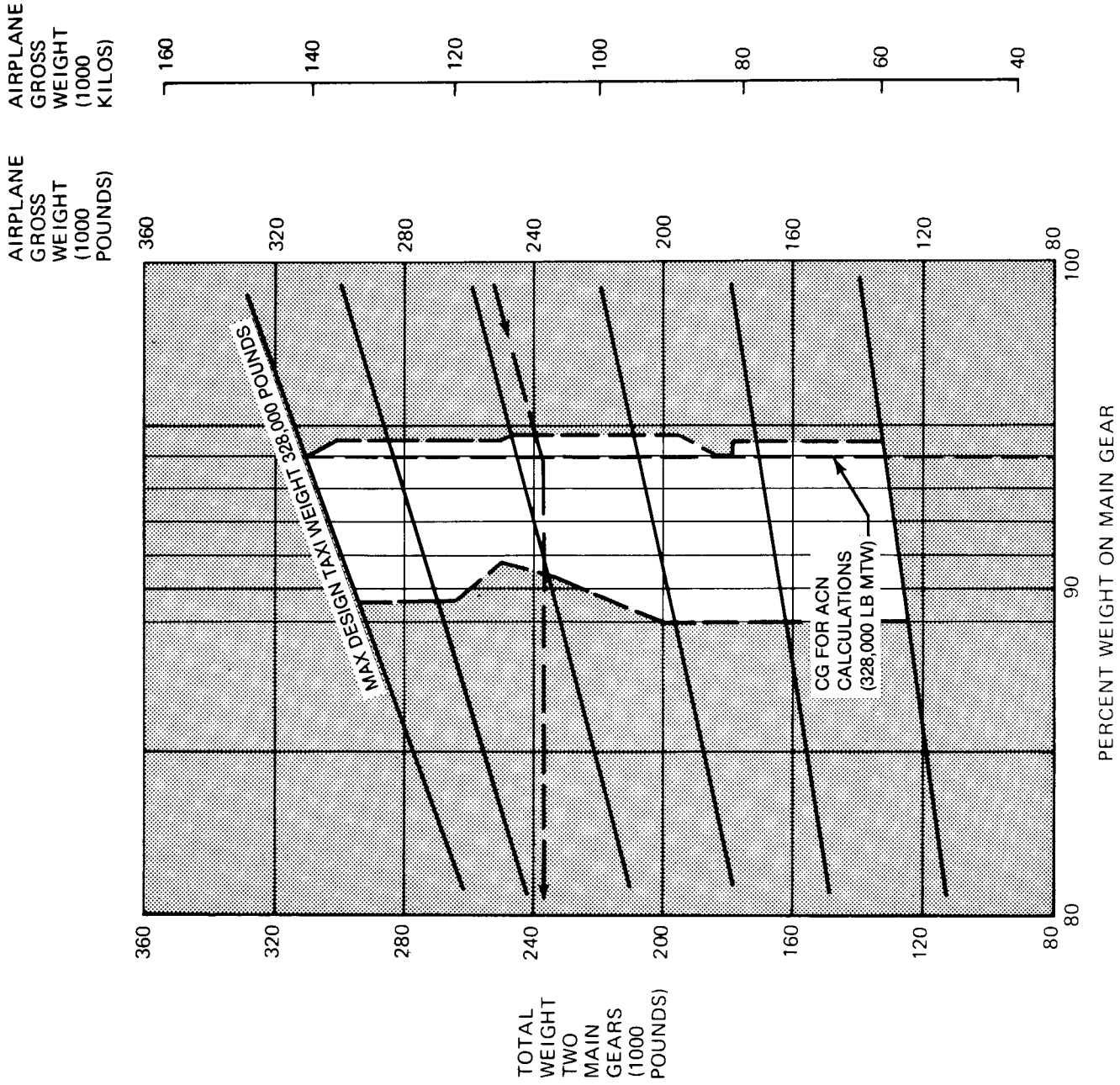

7.4 LANDING GEAR LOADING ON PAVEMENT MODEL DC-8-55

NOTE: UNSHADED AREAS REPRESENT OPERATIONAL LIMITS

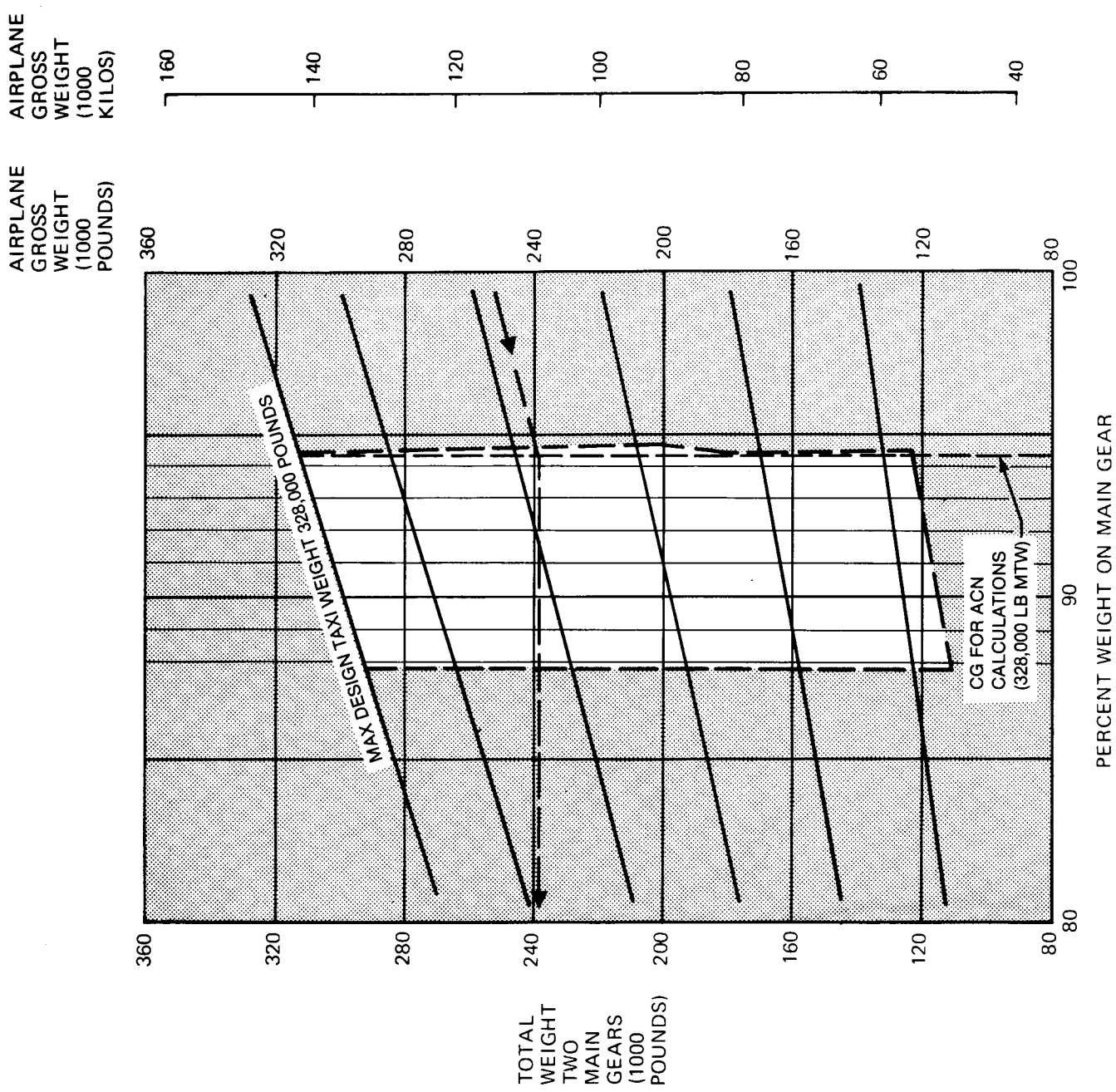

7.4 LANDING GEAR LOADING ON PAVEMENT MODEL DC-8-55F

NOTE: UNSHADED AREAS REPRESENT OPERATIONAL LIMITS

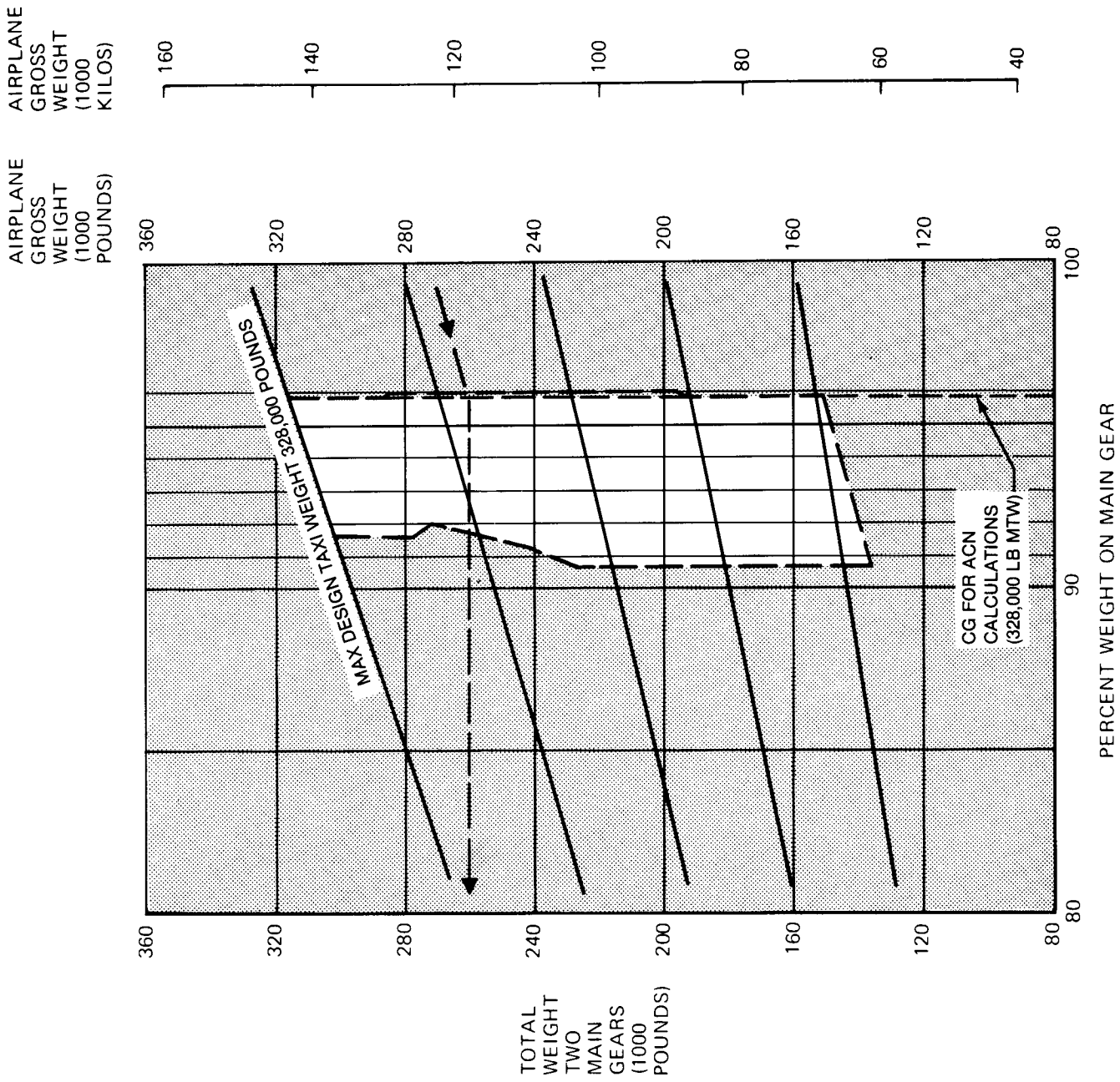

7.4 LANDING GEAR LOADING ON PAVEMENT MODEL DC-8-61, -71

NOTE: UNSHADED AREAS REPRESENT OPERATIONAL LIMITS

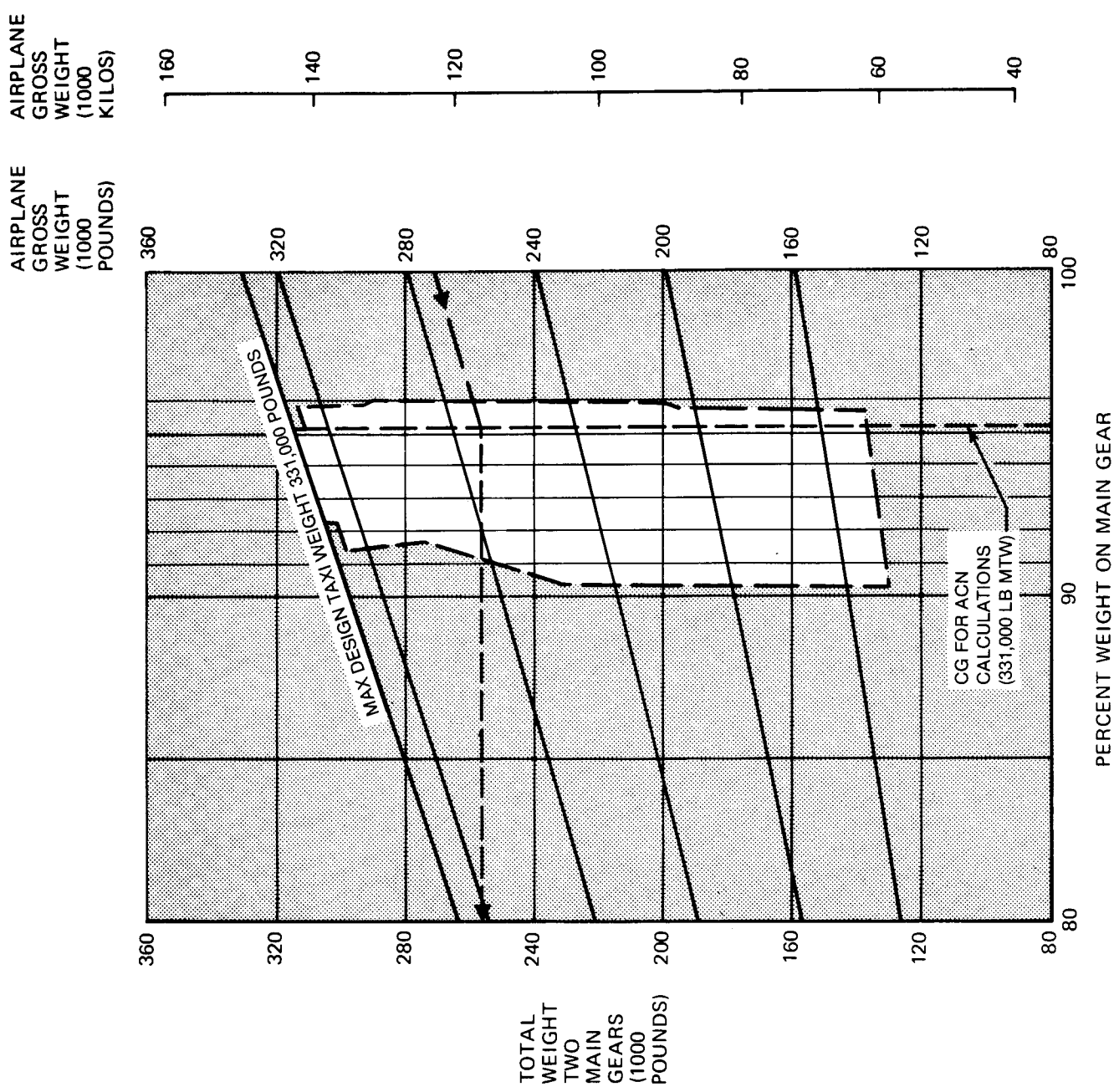

7.4 LANDING GEAR LOADING ON PAVEMENT MODEL DC-8-61F, -71F

NOTE: UNSHADED AREAS REPRESENT OPERATIONAL LIMITS

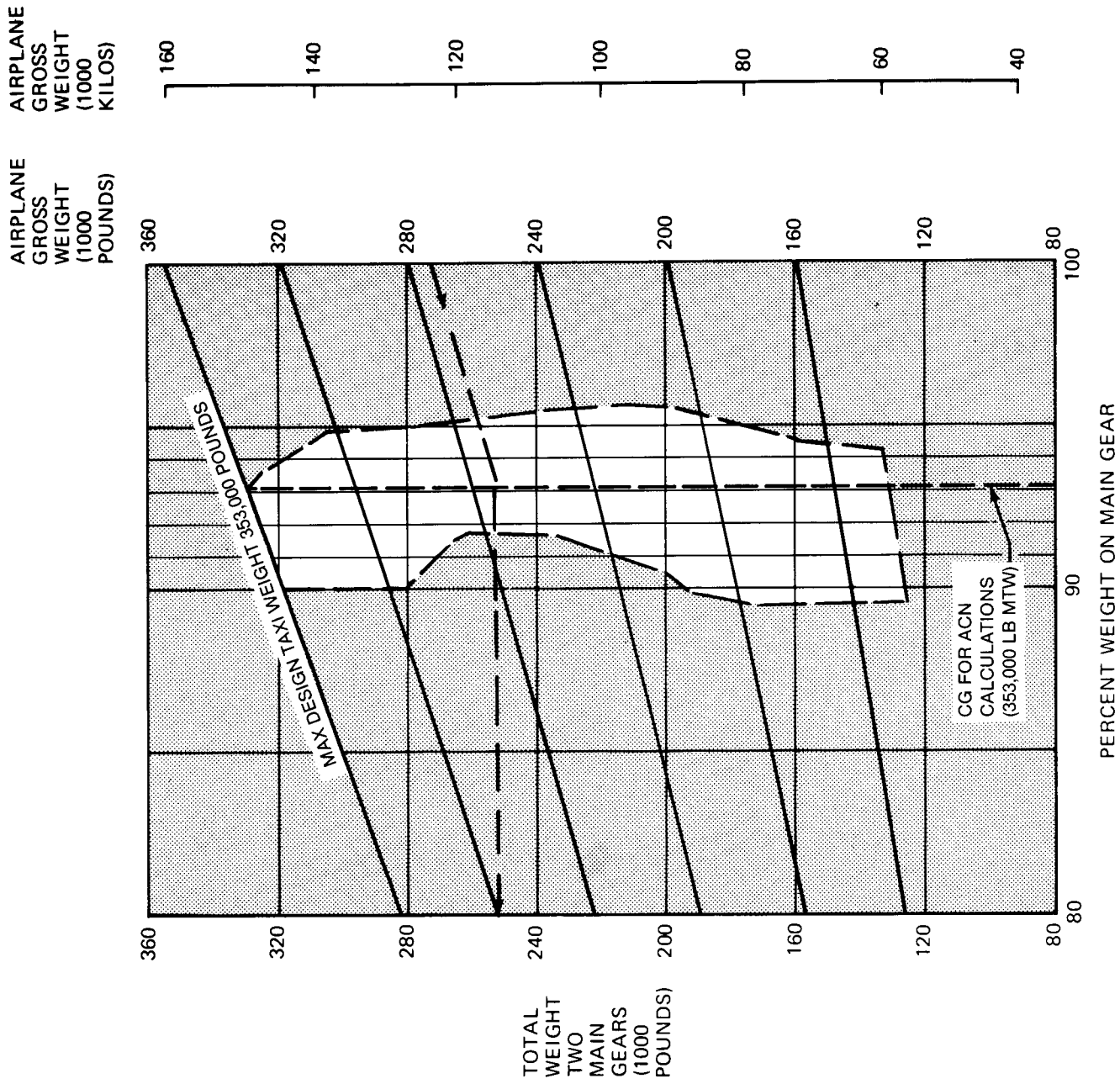

7.4 LANDING GEAR LOADING ON PAVEMENT MODEL DC-8-62, -72

NOTE: UNSHADED AREAS REPRESENT OPERATIONAL LIMITS

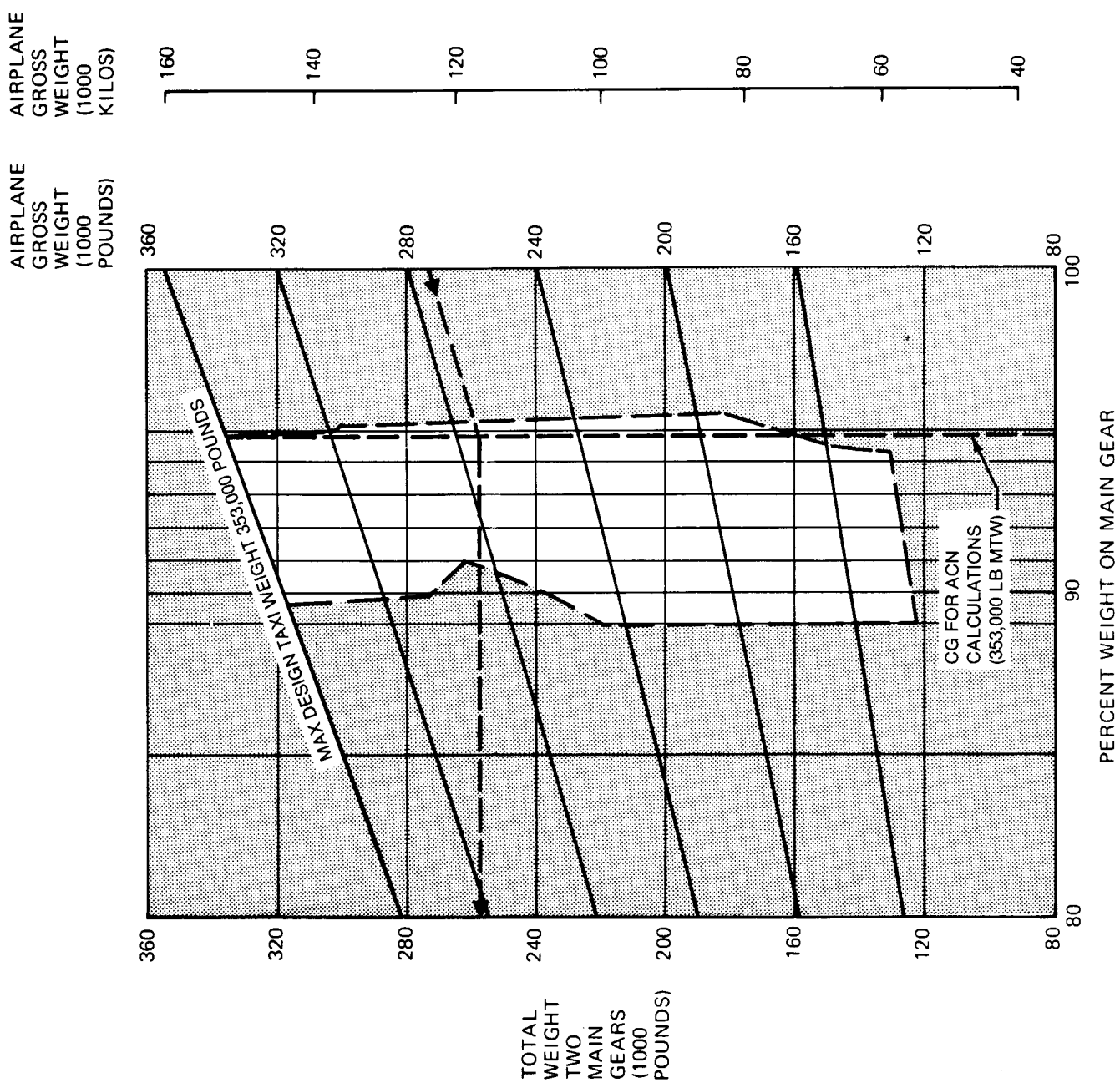

7.4 LANDING GEAR LOADING ON PAVEMENT MODEL DC-8-62F, -72F

NOTE: UNSHADED AREAS REPRESENT OPERATIONAL LIMITS

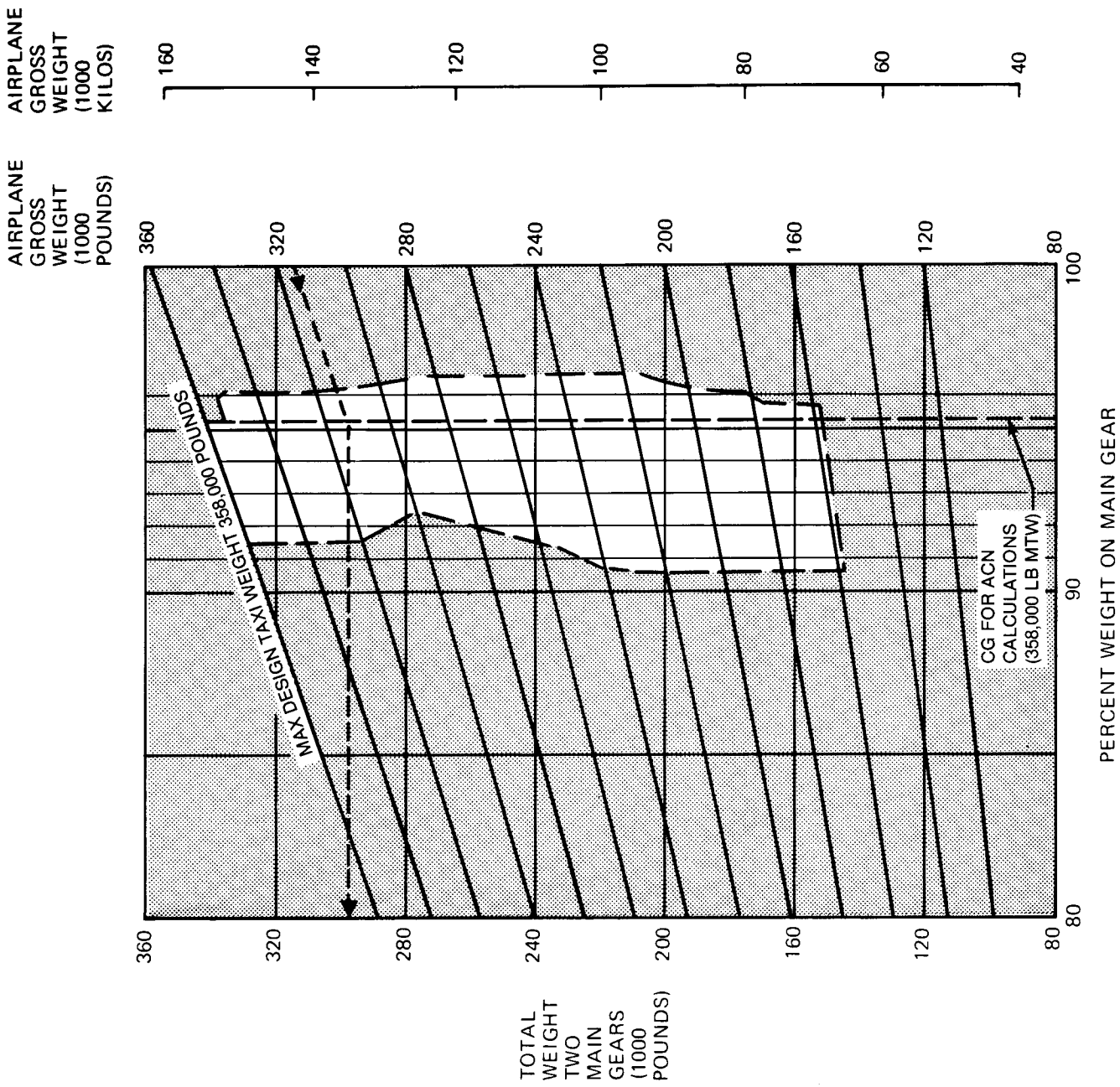

7.4 LANDING GEAR LOADING ON PAVEMENT MODEL DC-8-63, -73

NOTE: UNSHADED AREAS REPRESENT OPERATIONAL LIMITS

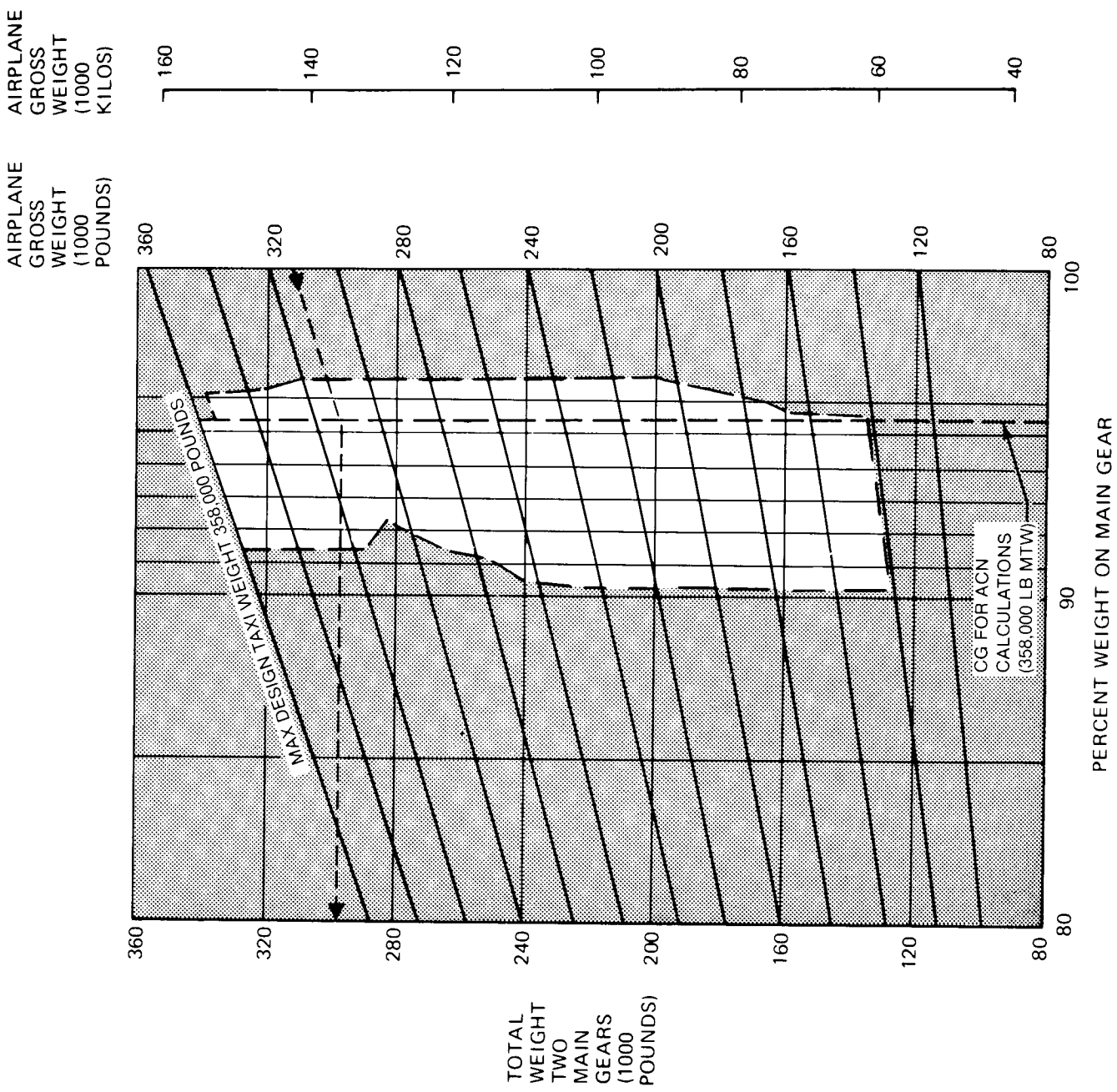

7.4 LANDING GEAR LOADING ON PAVEMENT MODEL DC-8-63F, -73F

TIRES: 44 X 16/44.5 X 16.5
 CONSTANT TIRE PRESSURE RANGE: 177 TO 196 PSI

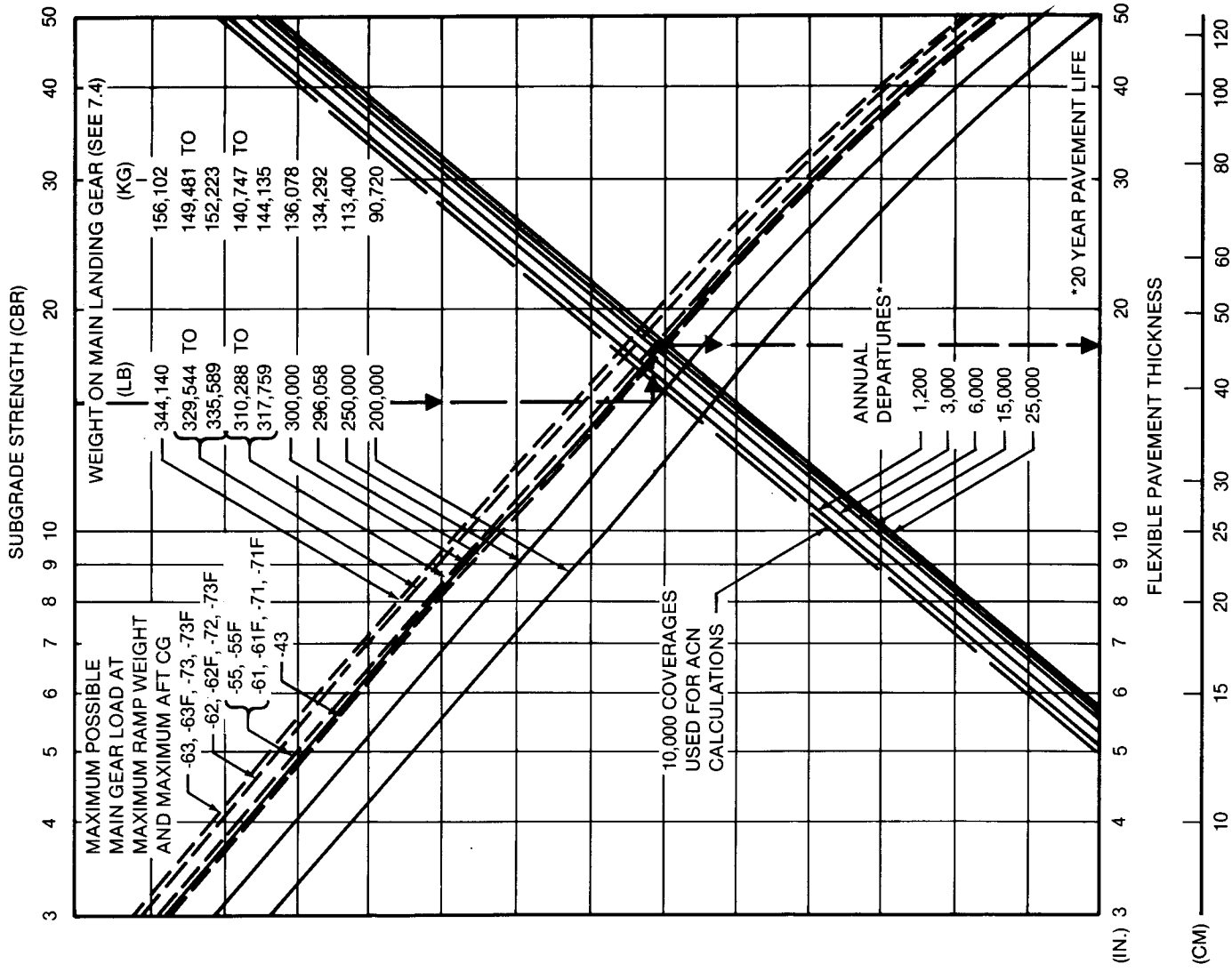

7.5 FLEXIBLE PAVEMENT REQUIREMENTS — U.S. CORPS OF ENGINEERS DESIGN METHOD

MODEL DC-8

7.6 Flexible Pavement Requirements, LCN Conversion

In order to determine the airplane weight that can be accommodated on a particular flexible airport pavement, both the LCN of the pavement and the thickness (h) of the pavement must be known.

In the example for the Model DC-8-43, the flexible pavement thickness is 30 inches, the LCN is 83, and the maximum weight permissible on the main landing gears is 250,000 pounds.

NOTE: EQUIVALENT SINGLE WHEEL LOADS ARE DERIVED BY METHODS SHOWN IN ICAO AERODROME MANUAL, PART 2, PARA 4.1.3

44 x 16 TIRES
TIRE PRESSURE CONSTANT AT 177 PSI

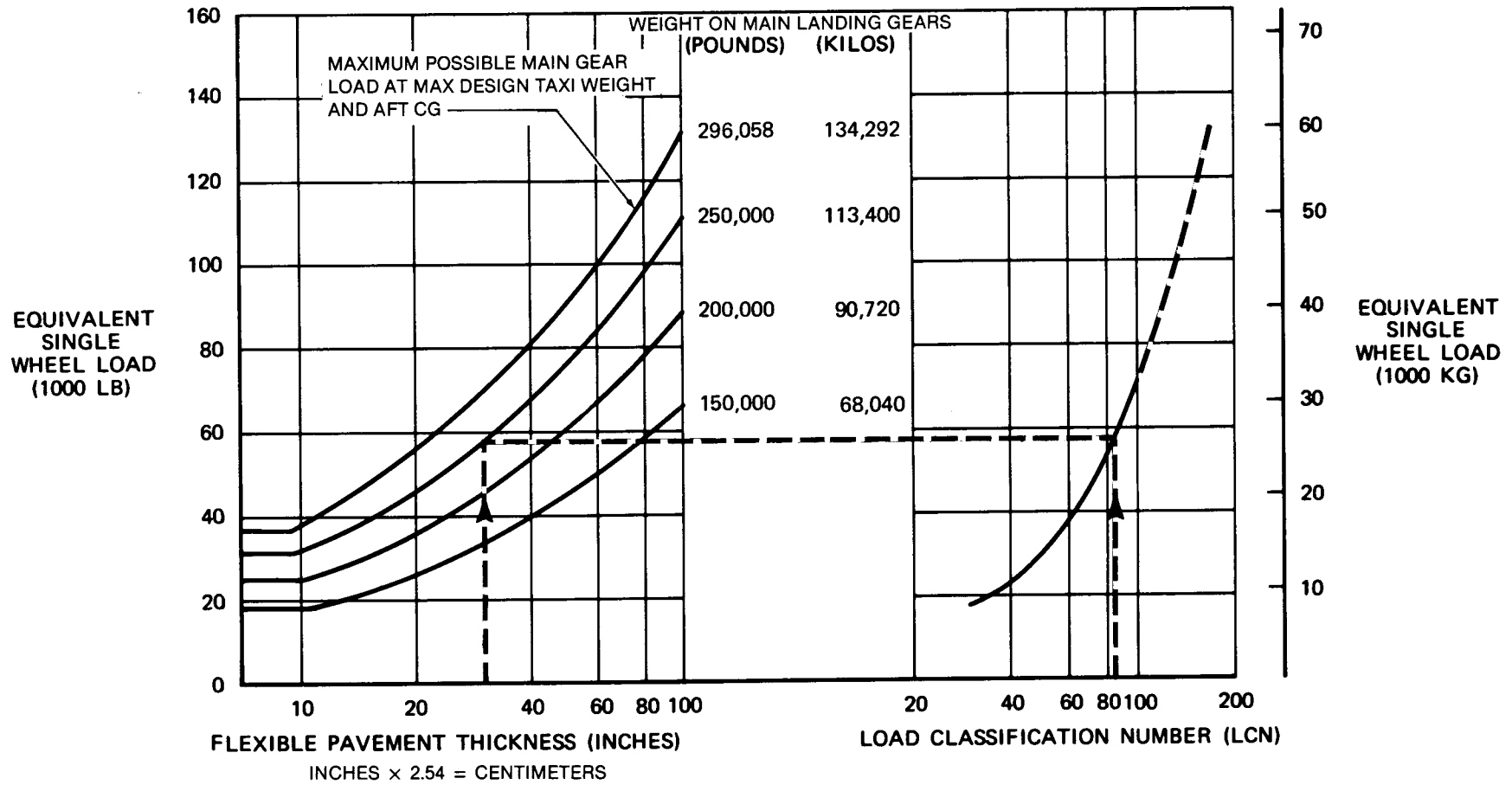

7.6 FLEXIBLE PAVEMENT REQUIREMENTS – LCN CONVERSION MODEL DC-8-43

NOTE: EQUIVALENT SINGLE WHEEL LOADS ARE DERIVED BY METHODS SHOWN IN ICAO AERODROME MANUAL, PART 2, PARA 4.1.3

44 x 16 TIRES
TIRE PRESSURE CONSTANT AT 186 PSI

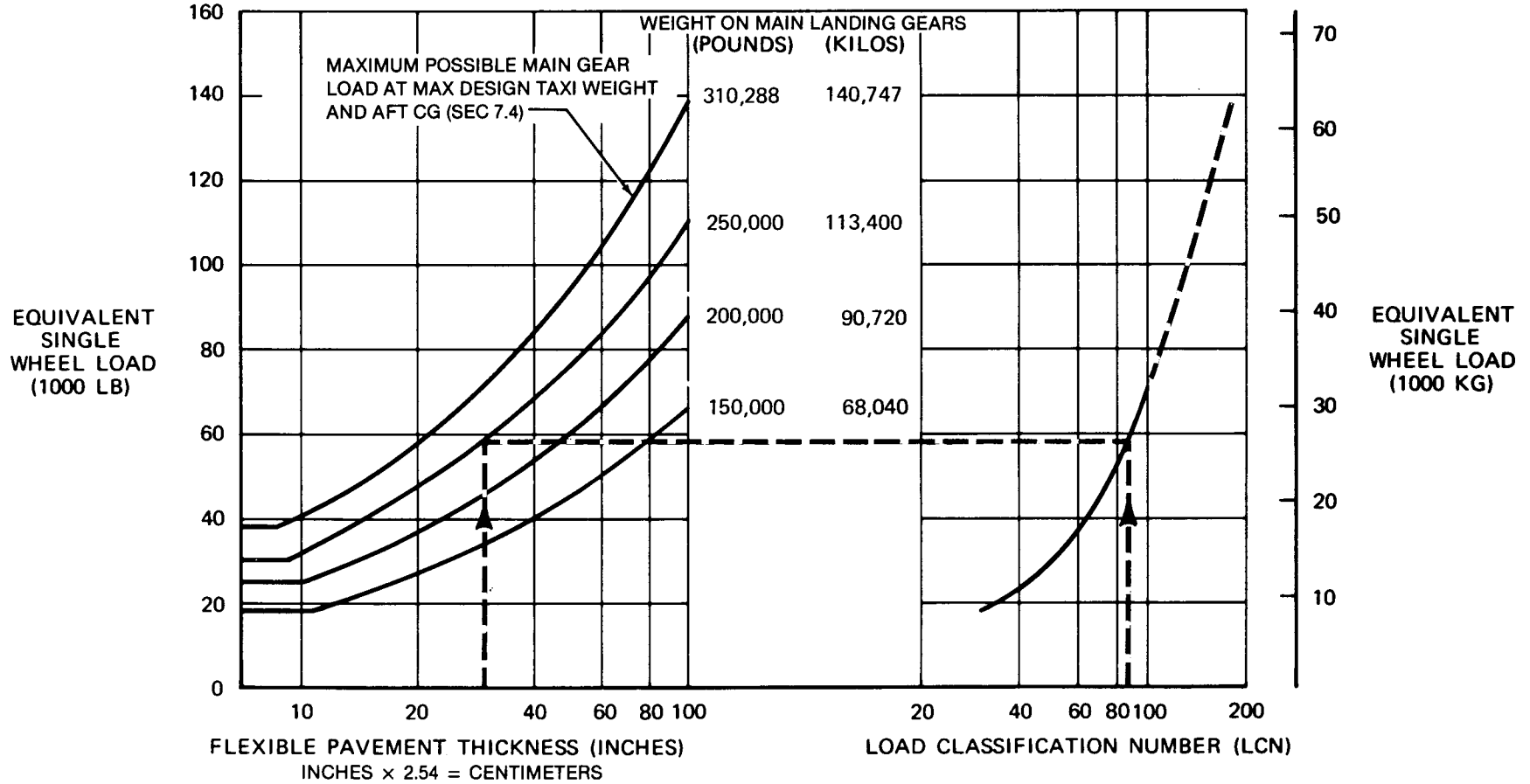

7.6 FLEXIBLE PAVEMENT REQUIREMENTS — LCN CONVERSION MODEL DC-8-55

NOTE: EQUIVALENT SINGLE WHEEL LOADS ARE DERIVED BY METHODS SHOWN IN ICAO AERODROME MANUAL, PART 2, PARA 4.1.3

44 x 16 TIRES
TIRE PRESSURE CONSTANT AT 186 PSI

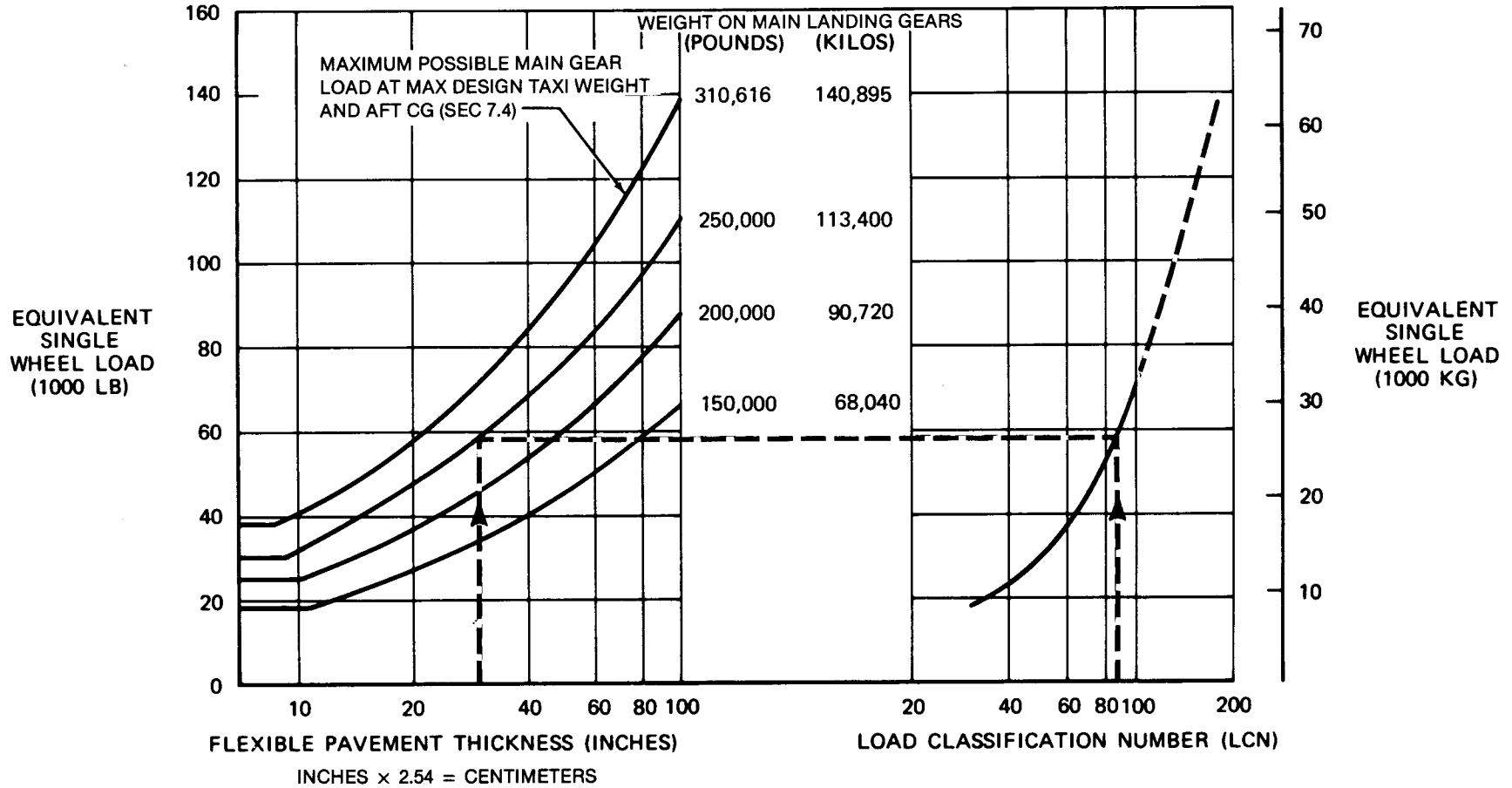

7.6 FLEXIBLE PAVEMENT REQUIREMENTS — LCN CONVERSION MODEL DC-8-55F

NOTE: EQUIVALENT SINGLE WHEEL LOADS ARE DERIVED BY METHODS SHOWN IN ICAO AERODROME MANUAL, PART 2, PARA 4.1.3

**44 x 16 TIRES
TIRE PRESSURE CONSTANT AT 188 PSI**

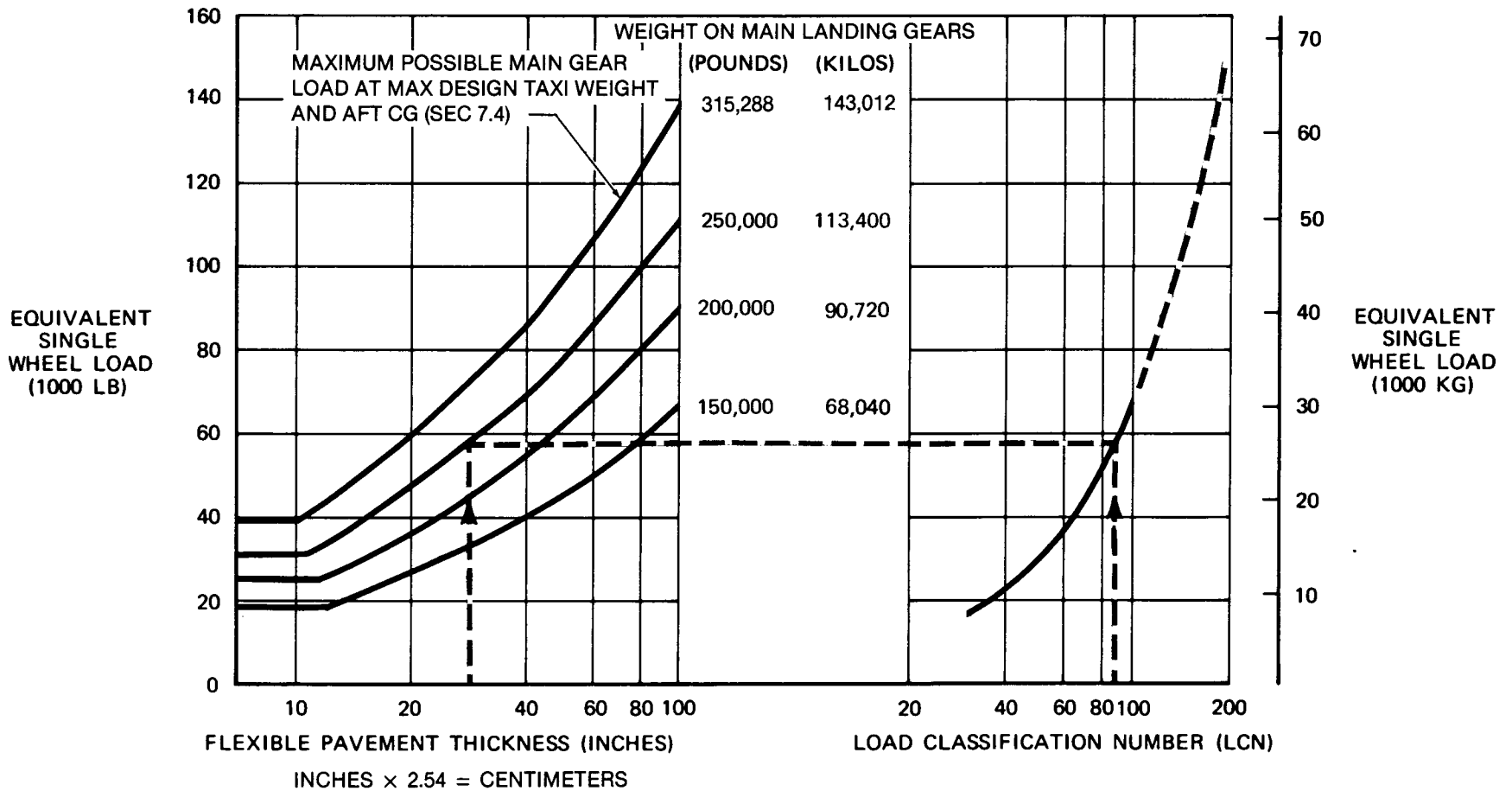

7.6 FLEXIBLE PAVEMENT REQUIREMENTS — LCN CONVERSION MODEL DC-8-61, -71

NOTE: EQUIVALENT SINGLE WHEEL LOADS ARE DERIVED BY METHODS SHOWN IN ICAO AERODROME MANUAL, PART 2, PARA 4.1.3

44 x 16 TIRES
TIRE PRESSURE CONSTANT AT 190 PSI

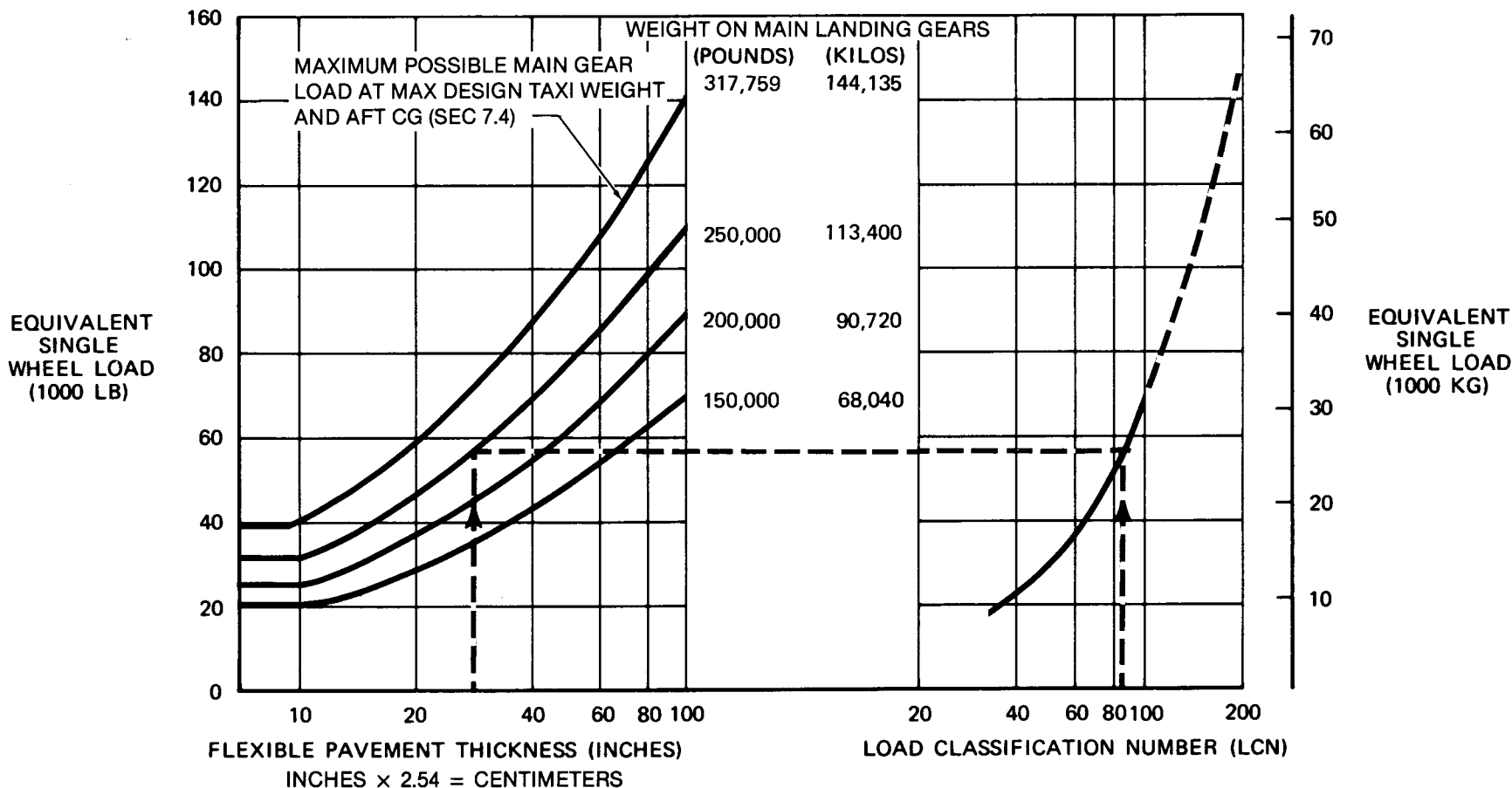

7.6 FLEXIBLE PAVEMENT REQUIREMENTS — LCN CONVERSION MODEL DC-8-61F, -71F

NOTE: EQUIVALENT SINGLE WHEEL LOADS ARE DERIVED BY METHODS SHOWN IN ICAO AERODROME MANUAL, PART 2, PARA 4.1.3

44.5 x 16.5 -18 TIRES
TIRE PRESSURE CONSTANT AT 191 PSI

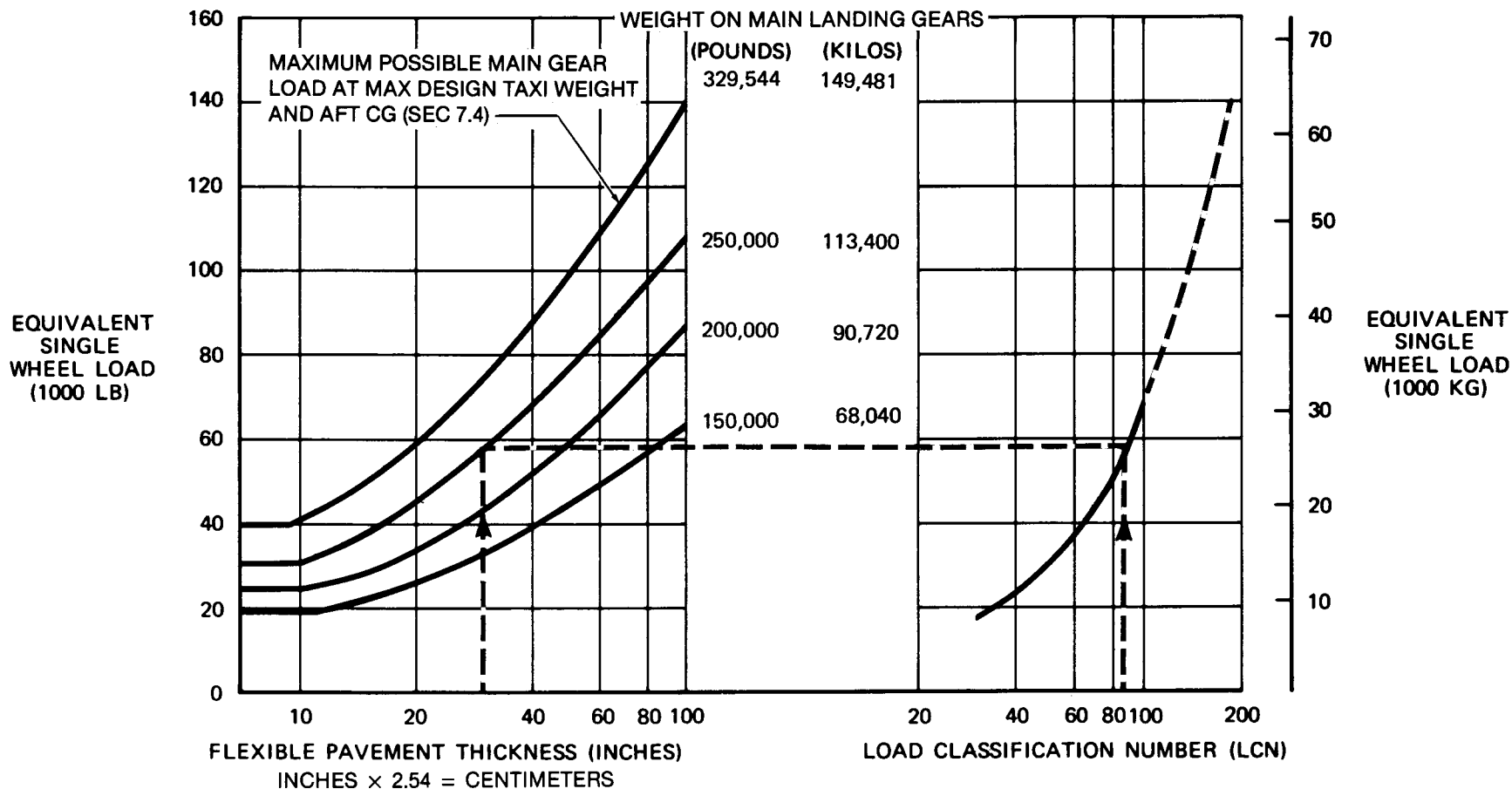

7.6 FLEXIBLE PAVEMENT REQUIREMENTS — LCN CONVERSION MODEL DC-8-62, -72

NOTE: EQUIVALENT SINGLE WHEEL LOADS ARE DERIVED BY METHODS SHOWN IN ICAO AERODROME MANUAL, PART 2, PARA 4.1.3

44.5 x 16.5 - 18 TIRES
TIRE PRESSURE CONSTANT AT 191 PSI

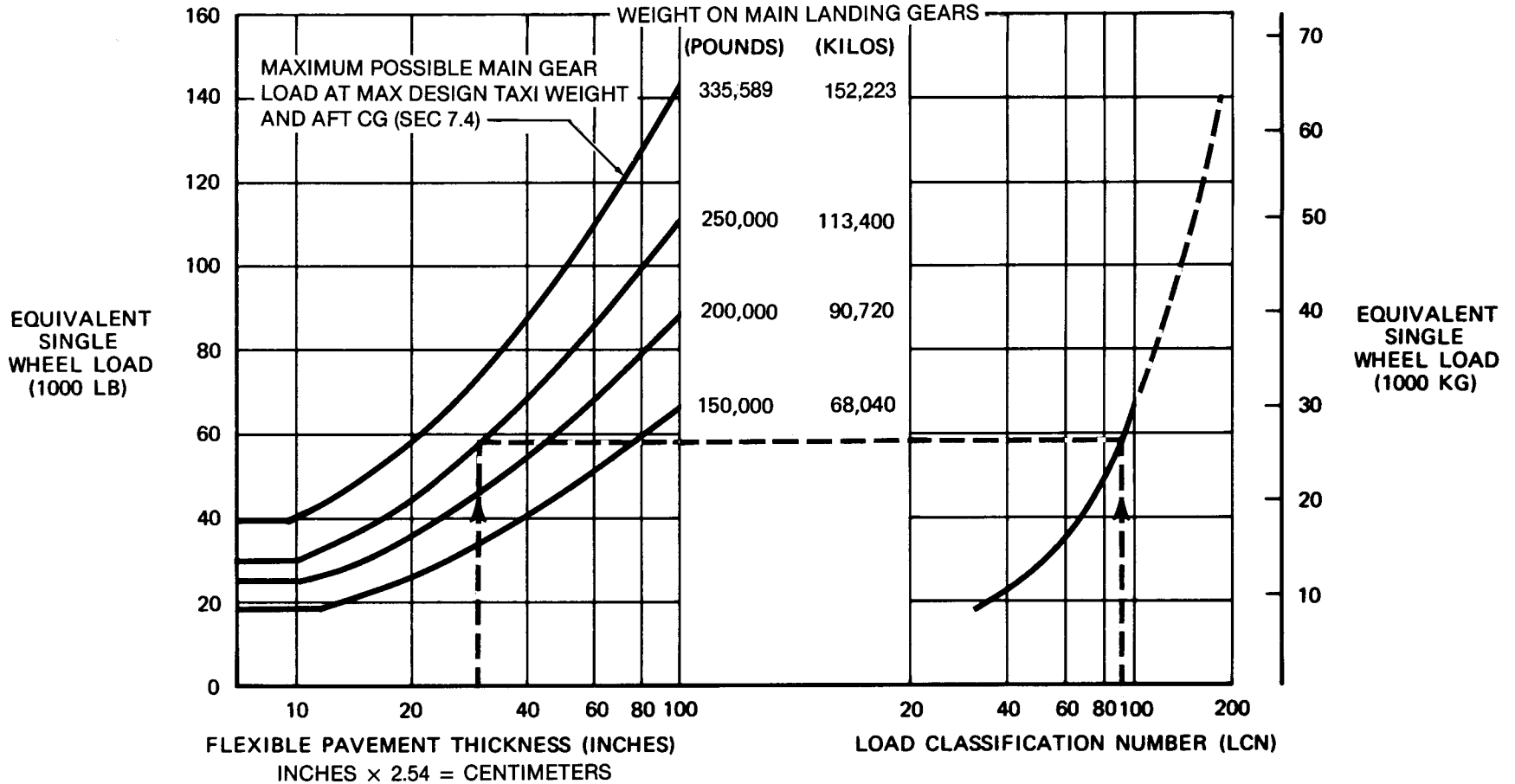

7.6 FLEXIBLE PAVEMENT REQUIREMENTS - LCN CONVERSION MODEL DC-8-62F, -72F

NOTE: EQUIVALENT SINGLE WHEEL LOADS ARE DERIVED BY METHODS SHOWN IN ICAO AERODROME MANUAL, PART 2, PARA 4.1.3

44.5 x 16.5 – 18 TIRES
TIRE PRESSURE CONSTANT AT 196 PSI

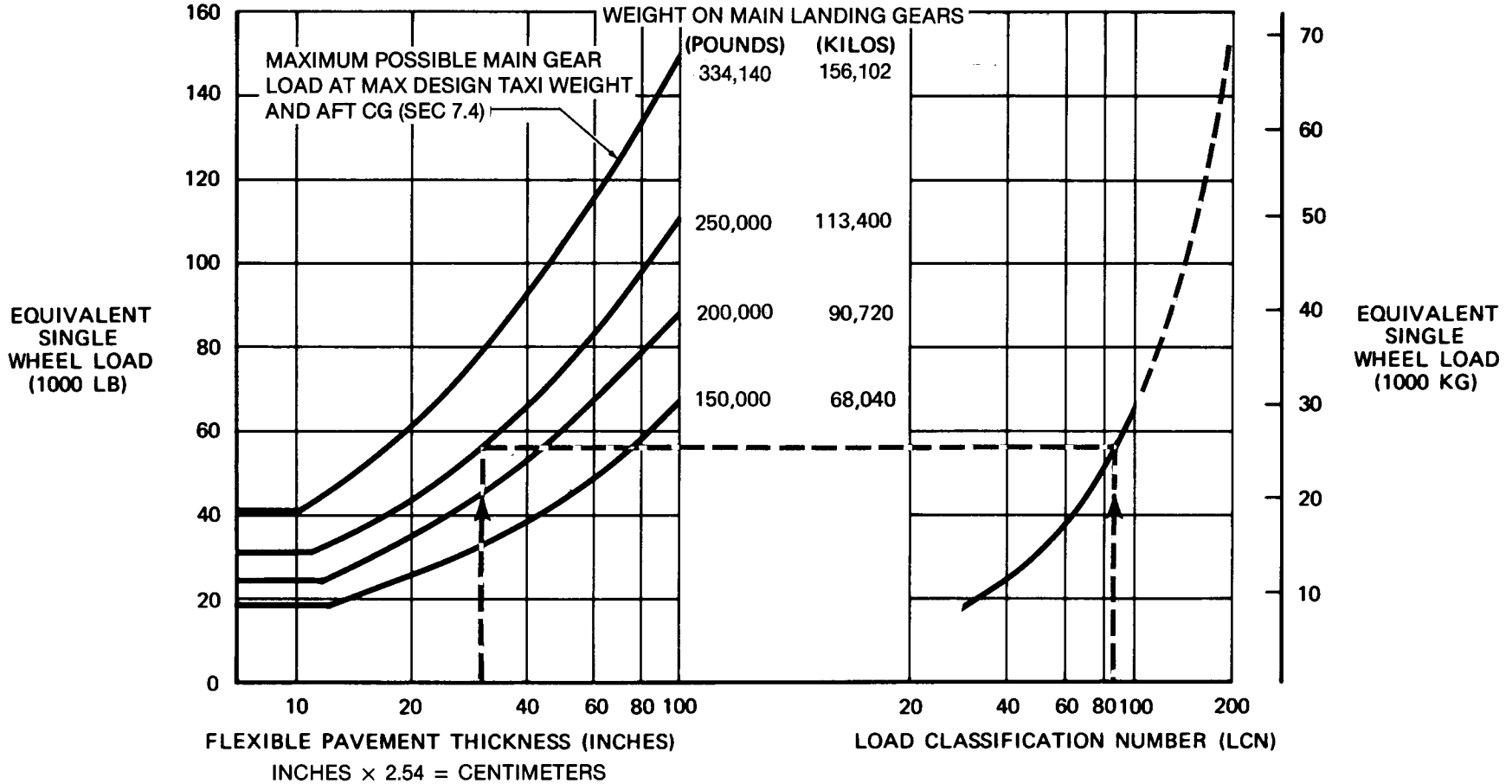

7.6 FLEXIBLE PAVEMENT REQUIREMENTS — LCN CONVERSION MODEL DC-8-63, -73

NOTE: EQUIVALENT SINGLE WHEEL LOADS ARE DERIVED BY METHODS SHOWN IN ICAO AERODROME MANUAL, PART 2, PARA 4.1.3

44.5 x 16.5 - 18 TIRES
TIRE PRESSURE CONSTANT AT 196 PSI

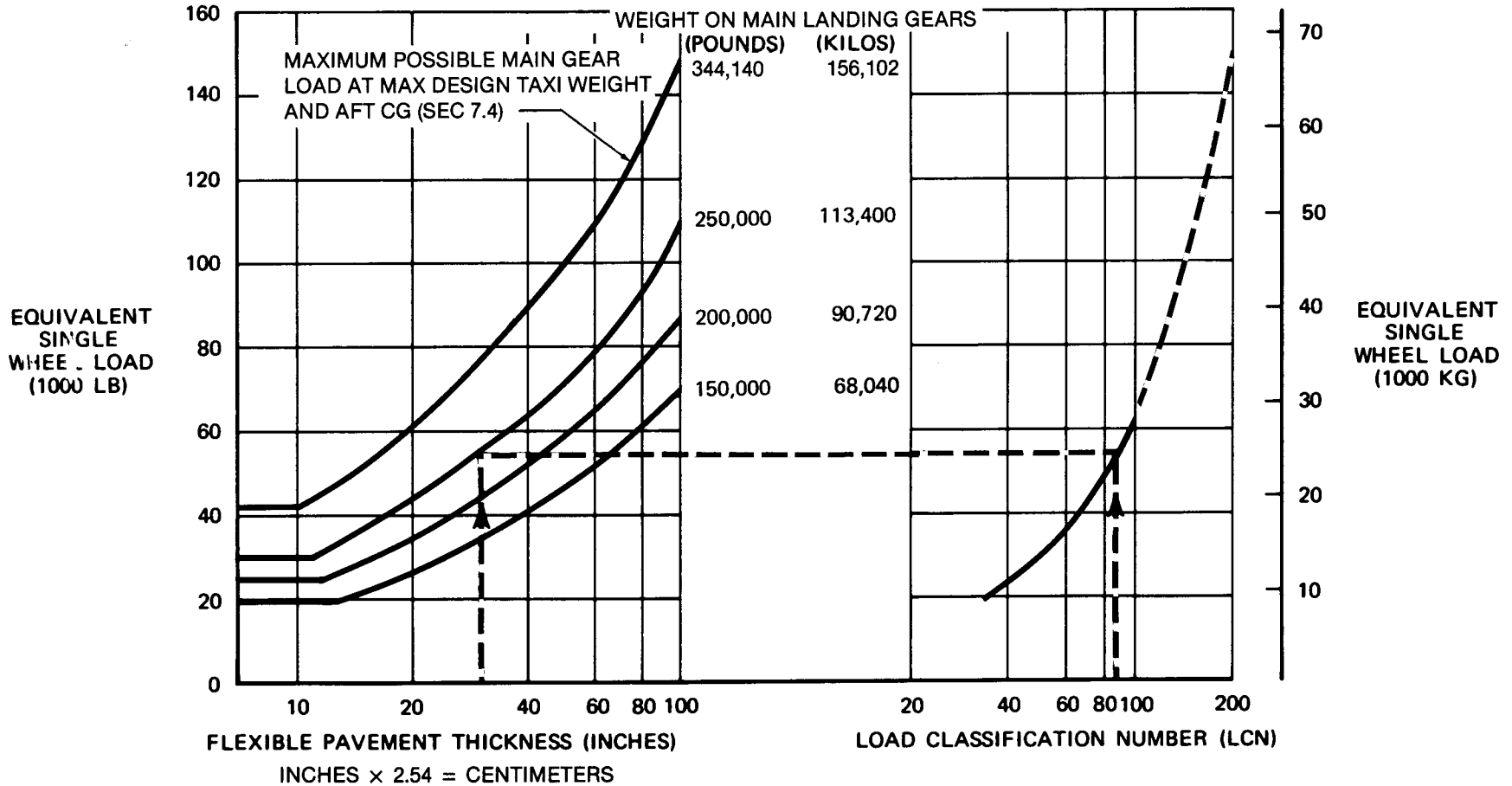

7.6 FLEXIBLE PAVEMENT REQUIREMENTS — LCN CONVERSION MODEL DC-8-63F, -73F

TIRE PRESSURE CONSTANT AT 177 PSI
44 x 16 TIRES

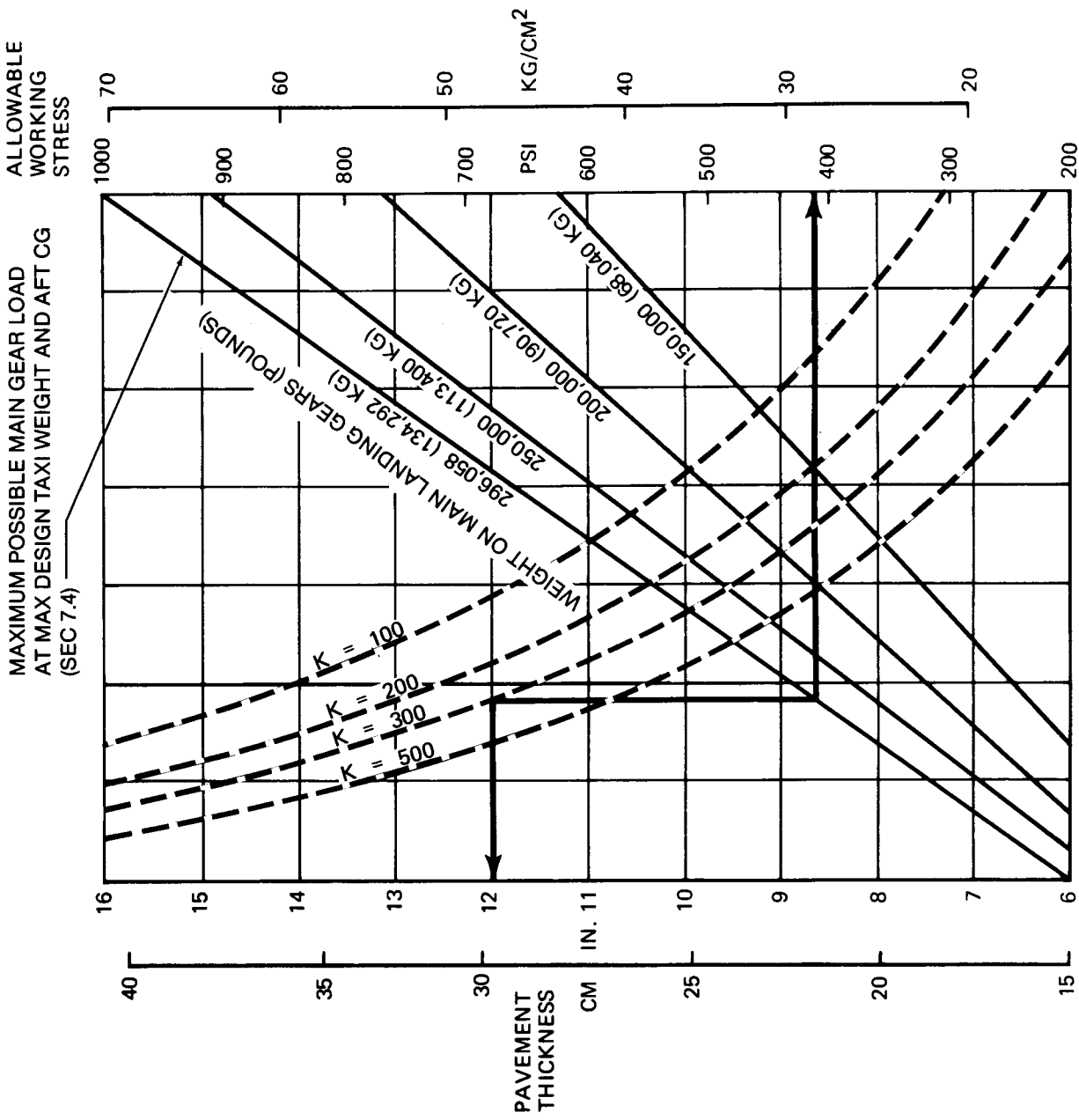

NOTE: THE VALUES OBTAINED BY USING THE
MAXIMUM LOAD REFERENCE LINE AND
ANY VALUE OF K ARE EXACT. FOR
LOADS LESS THAN MAXIMUM, THE CURVES
ARE EXACT FOR $K = 300$, BUT DEVIATE
SLIGHTLY FOR OTHER VALUES OF K.

REFERENCE: "DESIGN OF CONCRETE AIRPORT PAVEMENT" AND "COMPUTER PROGRAM FOR
AIRPORT PAVEMENT DESIGN — PROGRAM PDILB." PORTLAND CEMENT ASSN.

7.7 RIGID PAVEMENT REQUIREMENTS, PORTLAND CEMENT ASSOCIATION DESIGN METHOD

MODEL DC-8-43

TIRE PRESSURE CONSTANT AT 186 PSI
44 x 16 TIRES

MAXIMUM POSSIBLE MAIN GEAR LOAD
AT MAX DESIGN TAXI WEIGHT AND AFT CG
(SEC 7.4)

ALLOWABLE
WORKING
STRESS

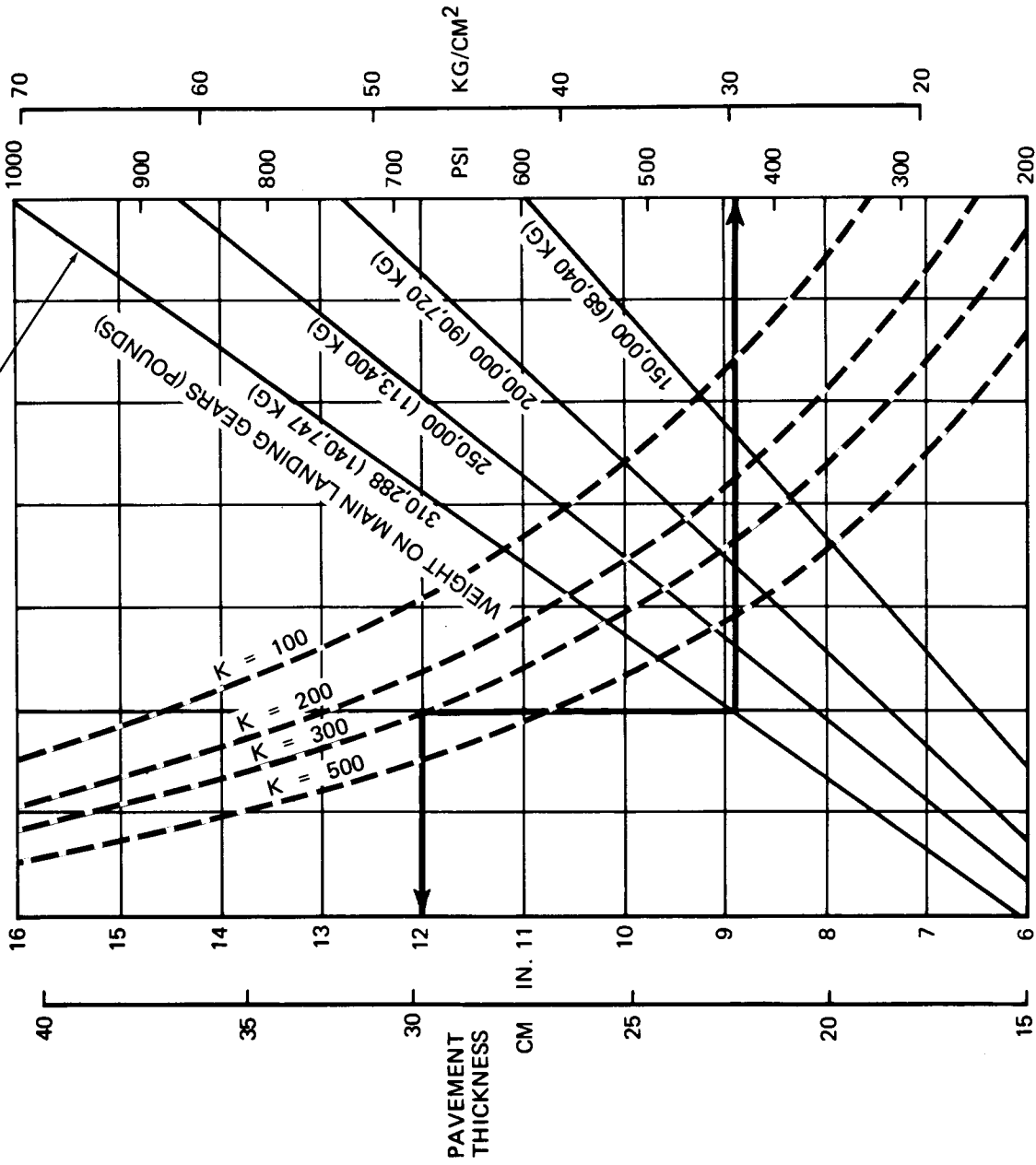

NOTE: THE VALUES OBTAINED BY USING THE
MAXIMUM LOAD REFERENCE LINE AND
ANY VALUE OF K ARE EXACT. FOR
LOADS LESS THAN MAXIMUM, THE CURVES
ARE EXACT FOR K = 300, BUT DEVIATE
SLIGHTLY FOR OTHER VALUES OF K.

REFERENCE: "DESIGN OF CONCRETE AIRPORT PAVEMENT" AND "COMPUTER PROGRAM FOR
AIRPORT PAVEMENT DESIGN — PROGRAM PDILB." PORTLAND CEMENT ASSN.

7.7 RIGID PAVEMENT REQUIREMENTS, PORTLAND CEMENT ASSOCIATION DESIGN METHOD

MODEL DC-8-55

TIRE PRESSURE CONSTANT AT 186 PSI
44 x 16 TIRES

MAXIMUM POSSIBLE MAIN GEAR LOAD
AT MAX DESIGN TAXI WEIGHT AND AFT CG
(SEC 7.4)

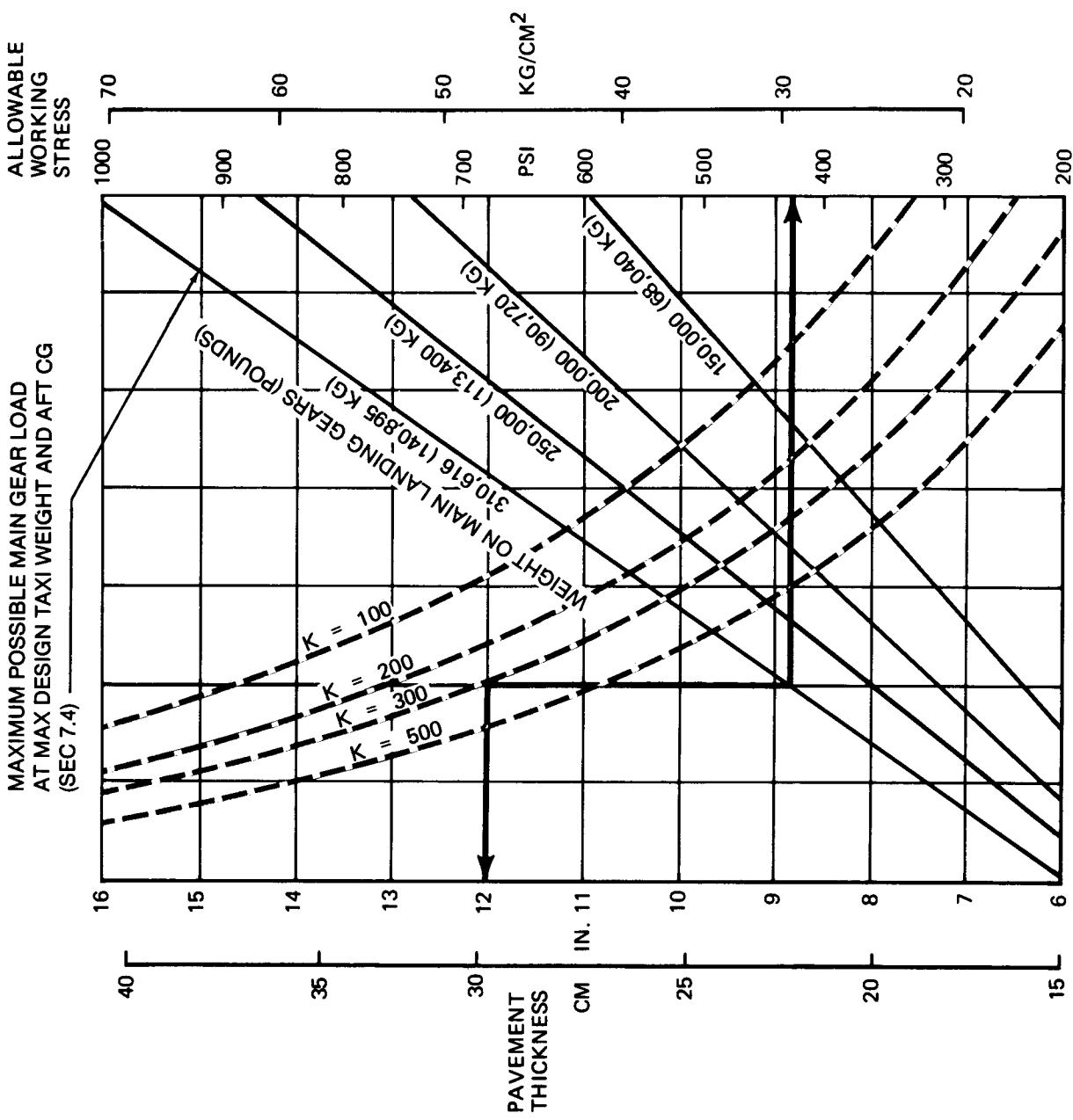

NOTE: THE VALUES OBTAINED BY USING THE
MAXIMUM LOAD REFERENCE LINE AND
ANY VALUE OF K ARE EXACT. FOR
LOADS LESS THAN MAXIMUM, THE CURVES
ARE EXACT FOR $K = 300$, BUT DEVIATE
SLIGHTLY FOR OTHER VALUES OF K.

REFERENCE: "DESIGN OF CONCRETE AIRPORT PAVEMENT" AND "COMPUTER PROGRAM FOR
AIRPORT PAVEMENT DESIGN — PROGRAM PDLB." PORTLAND CEMENT ASSN.

7.7 RIGID PAVEMENT REQUIREMENTS, PORTLAND CEMENT ASSOCIATION DESIGN METHOD

MODEL DC-8-55F

TIRE PRESSURE CONSTANT AT 188 PSI
44 x 16 TIRES

MAXIMUM POSSIBLE MAIN GEAR LOAD
AT MAX DESIGN TAXI WEIGHT AND AFT CG
(SEC 7.4)

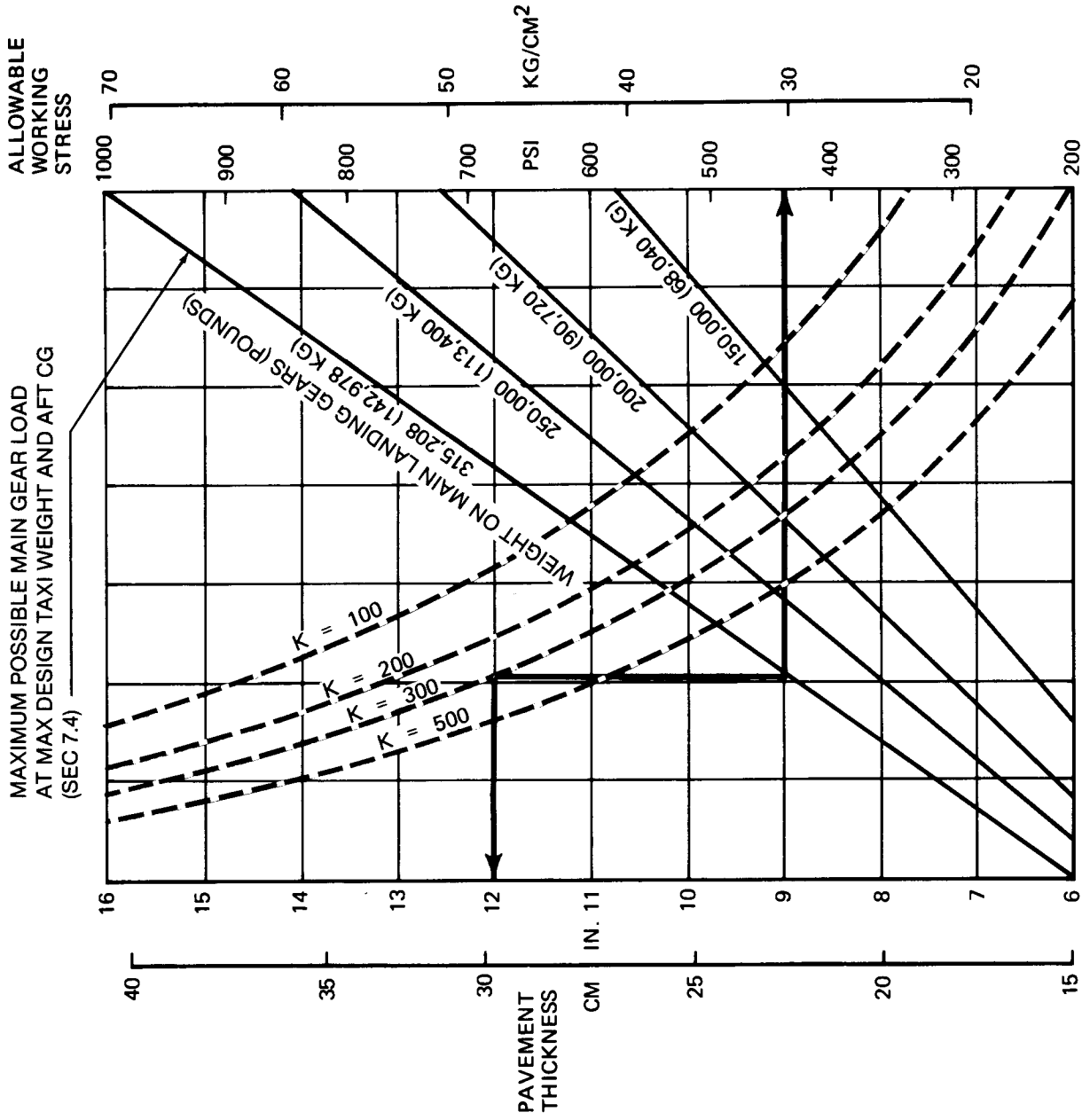

NOTE: THE VALUES OBTAINED BY USING THE
MAXIMUM LOAD REFERENCE LINE AND
ANY VALUE OF K ARE EXACT. FOR
LOADS LESS THAN MAXIMUM, THE CURVES
ARE EXACT FOR K = 300, BUT DEVIATE
SLIGHTLY FOR OTHER VALUES OF K.

REFERENCE: "DESIGN OF CONCRETE AIRPORT PAVEMENT" AND "COMPUTER PROGRAM FOR
AIRPORT PAVEMENT DESIGN — PROGRAM PDILB." PORTLAND CEMENT ASSN.

7.7 RIGID PAVEMENT REQUIREMENTS, PORTLAND CEMENT ASSOCIATION DESIGN METHOD

MODEL DC-8-61, -71

TIRE PRESSURE CONSTANT AT 190 PSI
44 x 16 TIRES

MAXIMUM POSSIBLE MAIN GEAR LOAD
AT MAX DESIGN TAXI WEIGHT AND AFT CG
(SEC 7.4)

ALLOWABLE
WORKING
STRESS

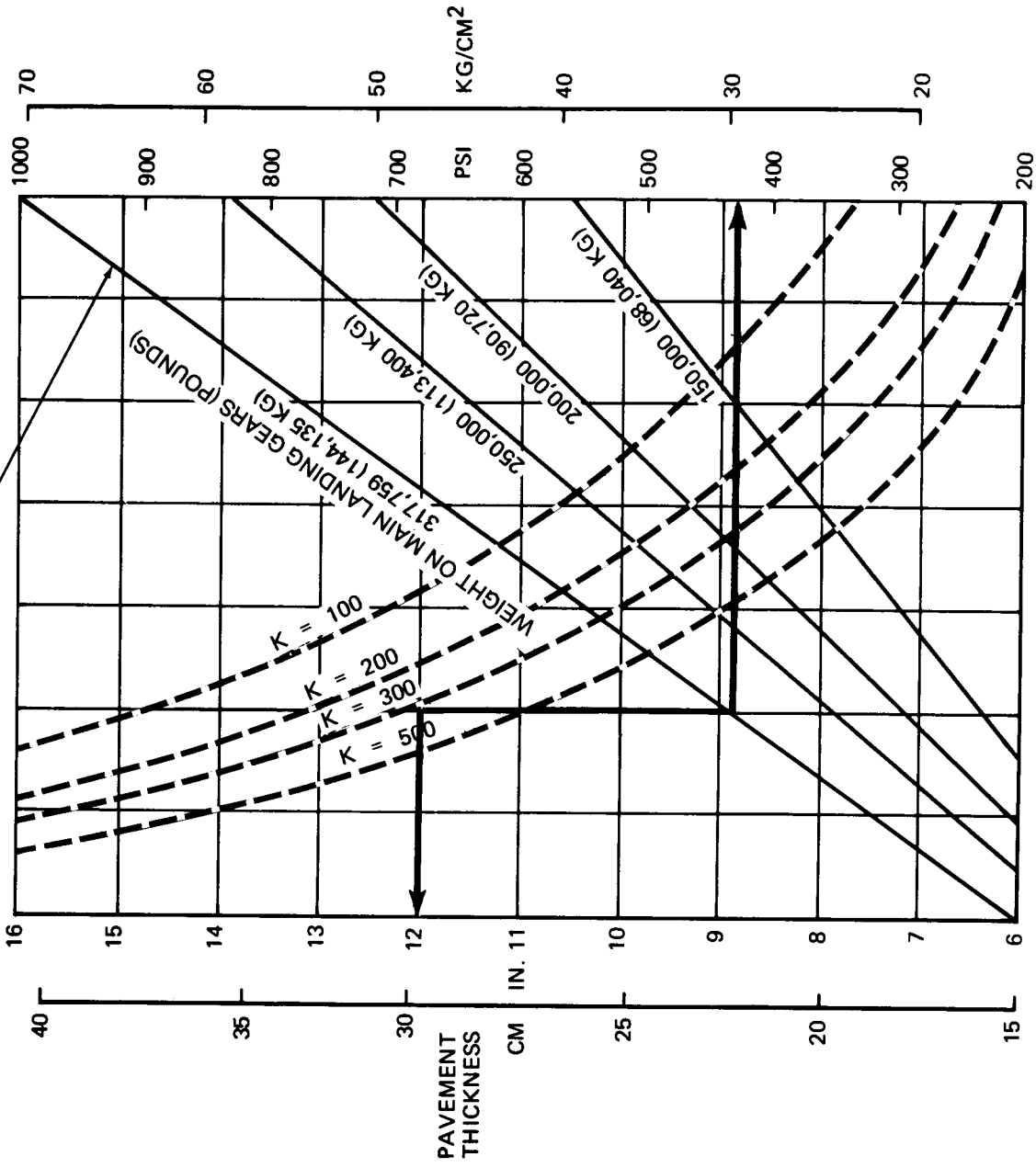

NOTE: THE VALUES OBTAINED BY USING THE
MAXIMUM LOAD REFERENCE LINE AND
ANY VALUE OF K ARE EXACT. FOR
LOADS LESS THAN MAXIMUM, THE CURVES
ARE EXACT FOR $K = 300$, BUT DEVIATE
SLIGHTLY FOR OTHER VALUES OF K.

REFERENCE: "DESIGN OF CONCRETE AIRPORT PAVEMENT" AND "COMPUTER PROGRAM FOR
AIRPORT PAVEMENT DESIGN — PROGRAM PDILB." PORTLAND CEMENT ASSN.

7.7 RIGID PAVEMENT REQUIREMENTS, PORTLAND CEMENT ASSOCIATION DESIGN METHOD

MODEL DC-8-61F, -71F

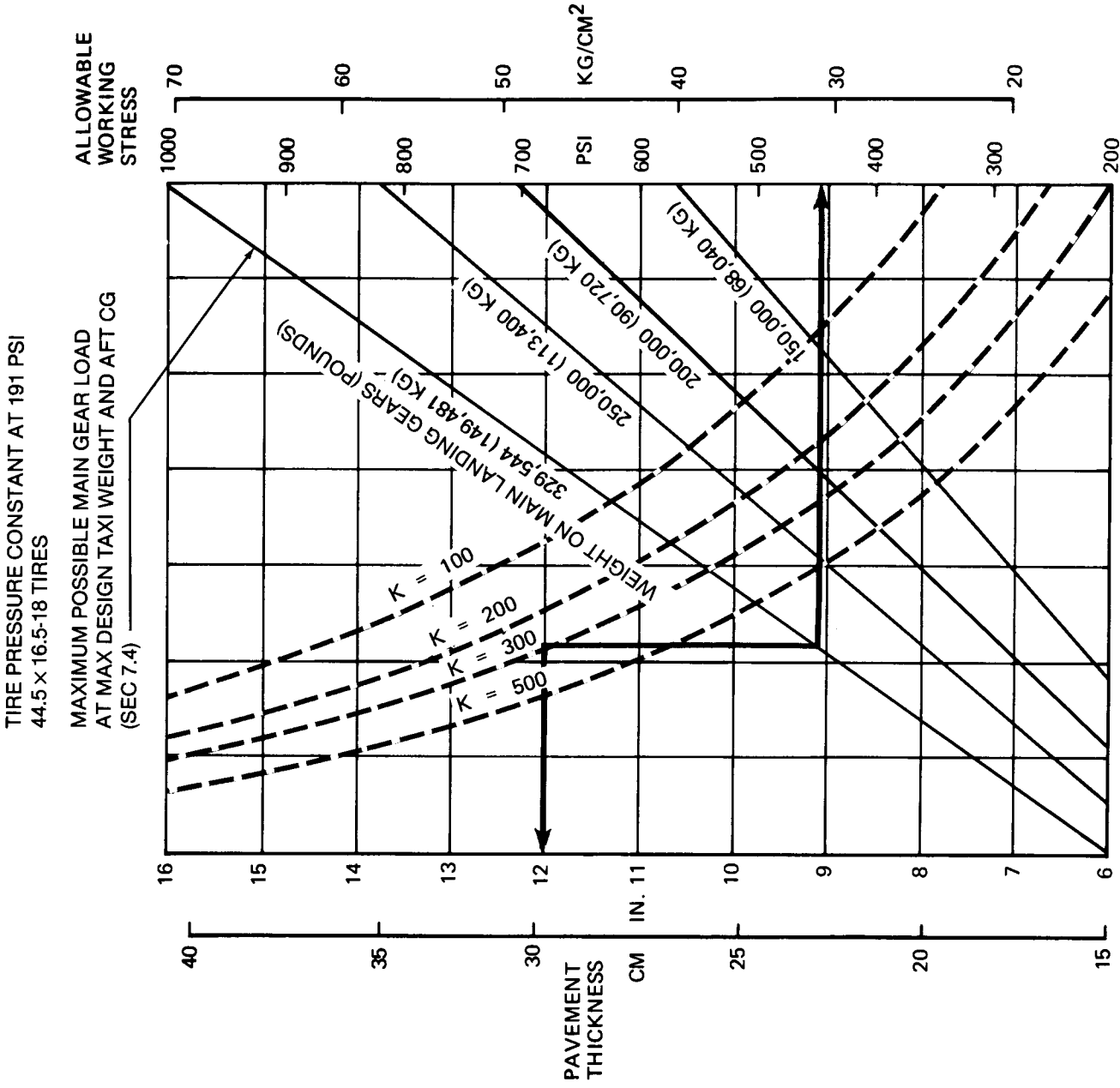

NOTE: THE VALUES OBTAINED BY USING THE
MAXIMUM LOAD REFERENCE LINE AND
ANY VALUE OF K ARE EXACT. FOR
LOADS LESS THAN MAXIMUM, THE CURVES
ARE EXACT FOR K = 300, BUT DEVIATE
SLIGHTLY FOR OTHER VALUES OF K.

REFERENCE: "DESIGN OF CONCRETE AIRPORT PAVEMENT" AND "COMPUTER PROGRAM FOR
AIRPORT PAVEMENT DESIGN — PROGRAM PDILB." PORTLAND CEMENT ASSN.

7.7 RIGID PAVEMENT REQUIREMENTS, PORTLAND CEMENT ASSOCIATION DESIGN METHOD

MODEL DC-8-62, -72

TIRE PRESSURE CONSTANT AT 191 PSI
44.5 x 16.5-18 TIRES

MAXIMUM POSSIBLE MAIN GEAR LOAD
AT MAX DESIGN TAXI WEIGHT AND AFT CG
(SEC 7.4)

ALLOWABLE
WORKING
STRESS

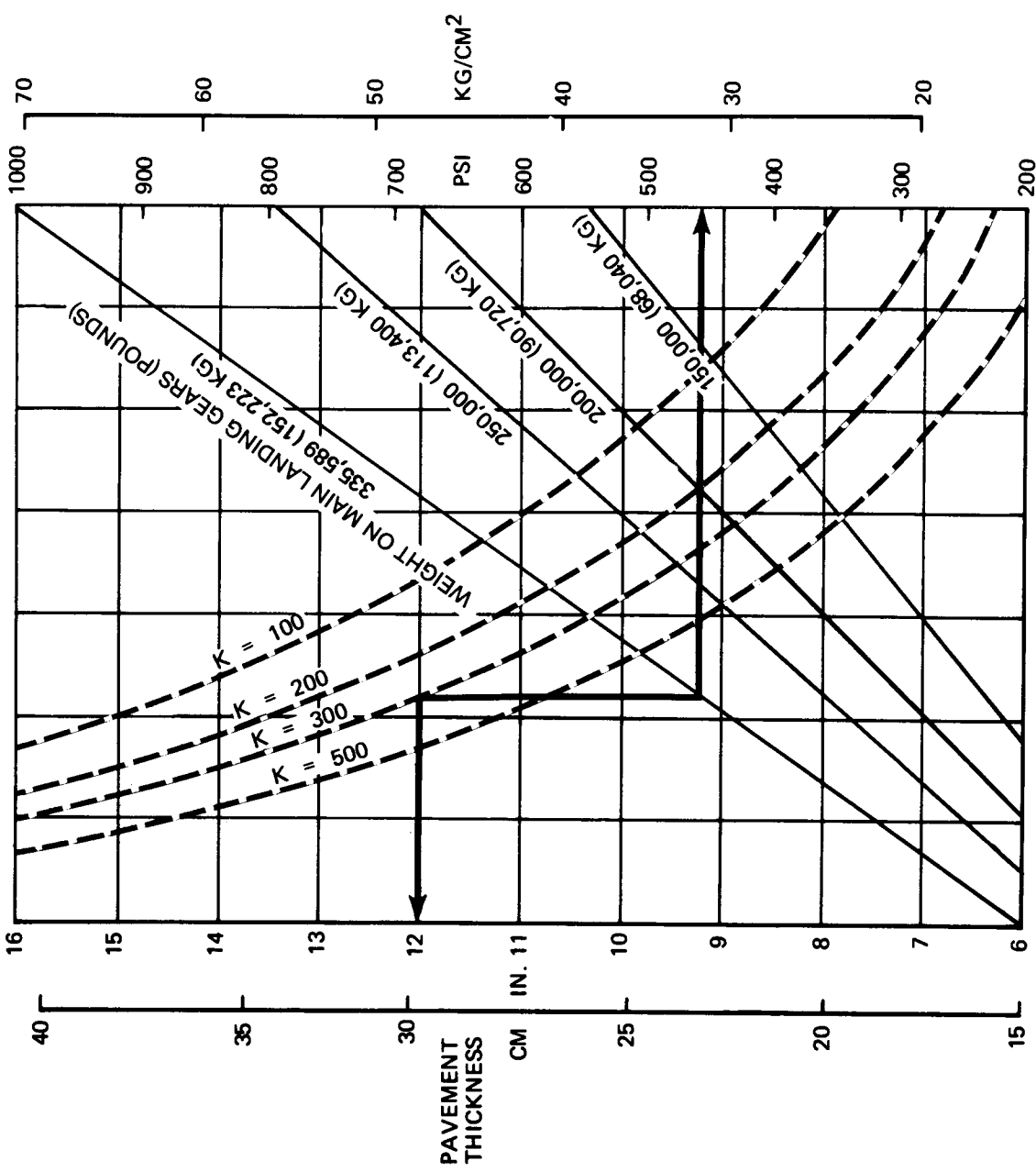

NOTE: THE VALUES OBTAINED BY USING THE
MAXIMUM LOAD REFERENCE LINE AND
ANY VALUE OF K ARE EXACT. FOR
LOADS LESS THAN MAXIMUM, THE CURVES
ARE EXACT FOR K = 300, BUT DEVIATE
SLIGHTLY FOR OTHER VALUES OF K.

REFERENCE: "DESIGN OF CONCRETE AIRPORT PAVEMENT" AND "COMPUTER PROGRAM FOR
AIRPORT PAVEMENT DESIGN — PROGRAM PDILB," PORTLAND CEMENT ASSN.

7.7 RIGID PAVEMENT REQUIREMENTS, PORTLAND CEMENT ASSOCIATION DESIGN METHOD

MODEL DC-8-62F, -72F

TIRE PRESSURE CONSTANT AT 196 PSI
44.5 x 16.5-18 TIRES

MAXIMUM POSSIBLE MAIN GEAR LOAD
AT MAX DESIGN TAXI WEIGHT AND AFT CG
(SEC 7.4)

ALLOWABLE
WORKING
STRESS

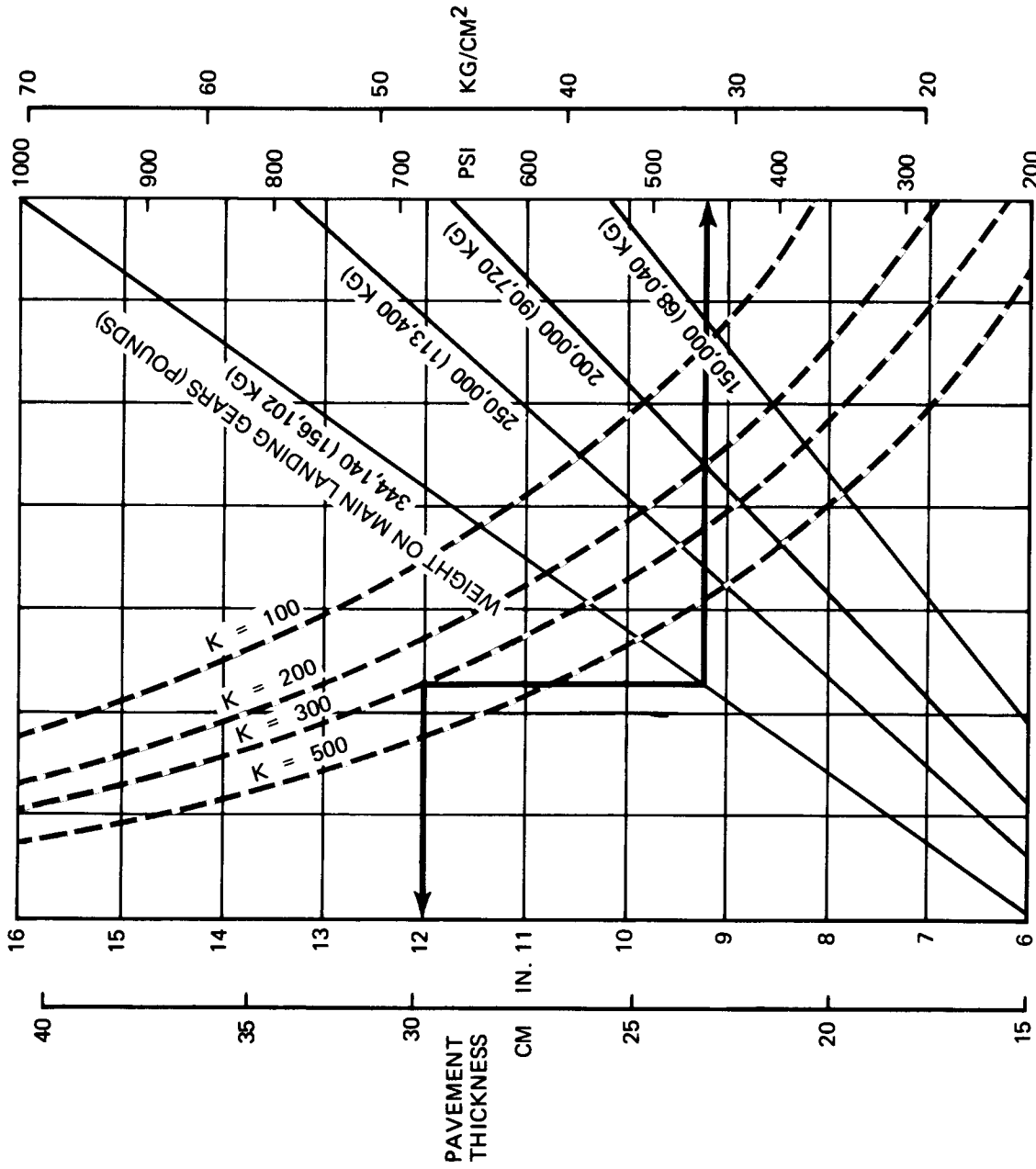

NOTE: THE VALUES OBTAINED BY USING THE
MAXIMUM LOAD REFERENCE LINE AND
ANY VALUE OF K ARE EXACT. FOR
LOADS LESS THAN MAXIMUM, THE CURVES
ARE EXACT FOR K = 300, BUT DEVIATE
SLIGHTLY FOR OTHER VALUES OF K.

REFERENCE: "DESIGN OF CONCRETE AIRPORT PAVEMENT" AND "COMPUTER PROGRAM FOR
AIRPORT PAVEMENT DESIGN — PROGRAM PDILB," PORTLAND CEMENT ASSN.

7.7 RIGID PAVEMENT REQUIREMENTS, PORTLAND CEMENT ASSOCIATION DESIGN METHOD

MODEL DC-8-63, -73

TIRE PRESSURE CONSTANT AT 196 PSI
44.5 x 16.5-18 TIRES

MAXIMUM POSSIBLE MAIN GEAR LOAD
AT MAX DESIGN TAXI WEIGHT AND AFT CG
(SEC 7.4)

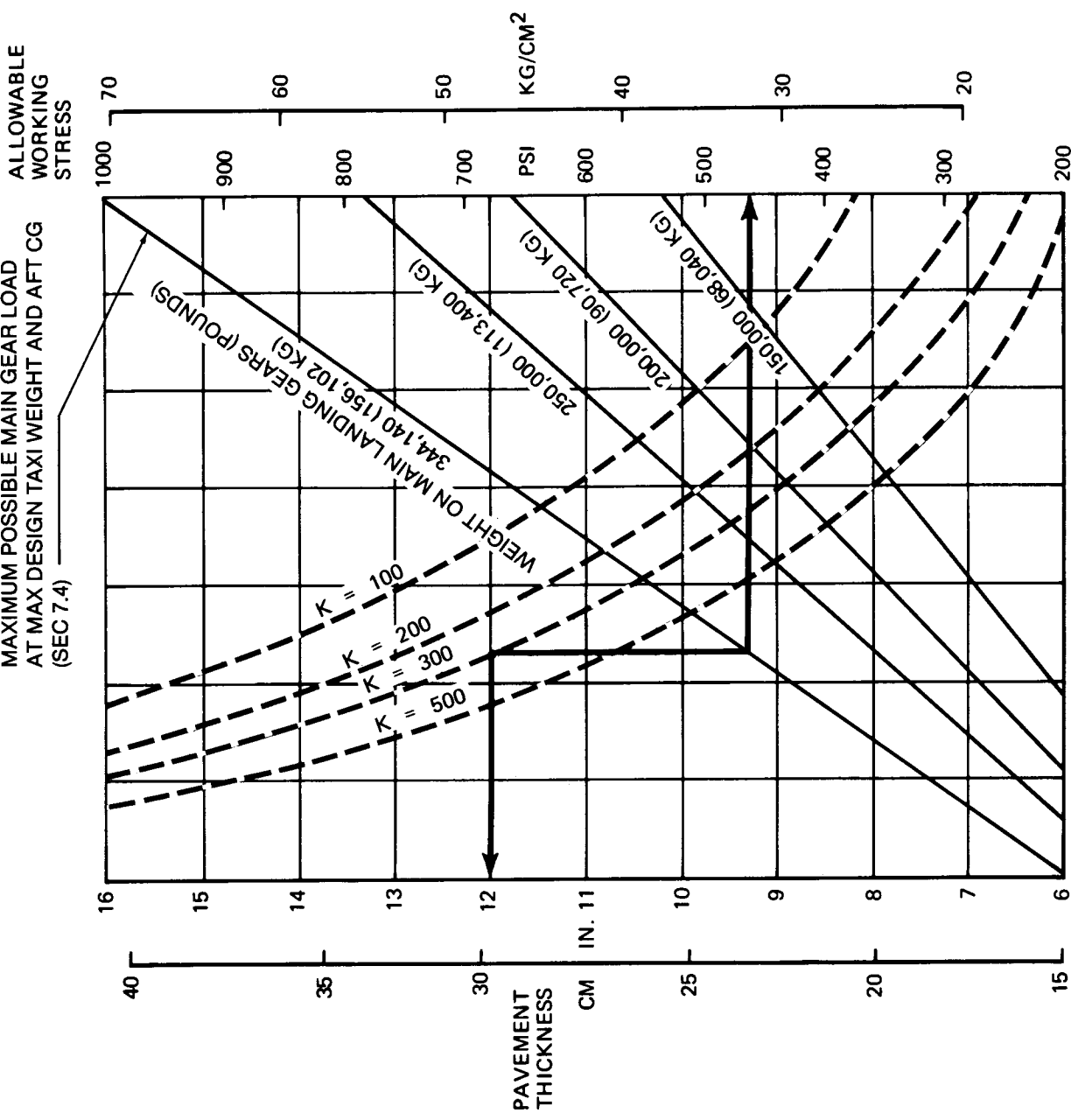

NOTE: THE VALUES OBTAINED BY USING THE
MAXIMUM LOAD REFERENCE LINE AND
ANY VALUE OF K ARE EXACT. FOR
LOADS LESS THAN MAXIMUM, THE CURVES
ARE EXACT FOR K = 300, BUT DEVIATE
SLIGHTLY FOR OTHER VALUES OF K.

REFERENCE: "DESIGN OF CONCRETE AIRPORT PAVEMENT" AND "COMPUTER PROGRAM FOR
AIRPORT PAVEMENT DESIGN — PROGRAM PDILB." PORTLAND CEMENT ASSN.

7.7 RIGID PAVEMENT REQUIREMENTS, PORTLAND CEMENT ASSOCIATION DESIGN METHOD

MODEL DC-8-63F, -73F

7.8 Rigid Pavement Requirements, LCN Conversion

In order to determine the airplane weight that can be accommodated on a particular rigid airport pavement, both the LCN of the pavement and the radius of relative stiffness must be known.

In the example for the Model DC-8-43, the rigid pavement radius of relative stiffness is 54 inches, the maximum weight permissible on the main landing gear is 200,000 pounds, and the LCN is 68.

The chart of Section 7.8.1 presents ℓ -values based on Young's Modulus (E) of 4,000,000 psi and Poisson's Ratio (μ) of 0.15. For convenience in finding ℓ -values based on other values of E and μ , the curves of Section 7.8.2 are included. For example, to find an ℓ -value based on E of 3,000,000 psi, the "E" factor of 0.931 is multiplied by the ℓ -value found in the table of Section 7.8.1. The effect of variations of " μ " on the ℓ -value is treated in a similar manner.

RADIUS OF RELATIVE STIFFNESS (ℓ)

VALUES OF ℓ IN INCHES
 WHERE: E = YOUNG'S MODULUS = 4×10^6 PSI
 k = SUBGRADE MODULUS, LB/IN.³
 d = RIGID-PAVEMENT THICKNESS, IN.
 μ = POISSON'S RATIO = 0.15

$$\text{RADIUS OF RELATIVE STIFFNESS} = \ell = \sqrt[4]{\frac{Ed^3}{12(1-\mu^2)k}} = 24.1652 \sqrt[4]{\frac{d^3}{k}}$$

d Inches	k=50	k=100	k=150	k=200	k=250	k=300	k=350	k=400	k=500
6.0	34.84	29.30	26.47	24.63	23.30	22.26	21.42	20.72	19.59
6.5	36.99	31.11	28.11	26.16	24.74	23.64	22.74	22.00	20.80
7.0	39.11	32.89	29.72	27.65	26.15	24.99	24.04	23.25	21.99
7.5	41.19	34.63	31.29	29.12	27.54	26.32	25.32	24.49	23.16
8.0	43.23	36.35	32.85	30.57	28.91	27.62	26.58	25.70	24.31
8.5	45.24	38.04	34.37	31.99	30.25	28.91	27.81	26.90	25.44
9.0	47.22	39.71	35.88	33.39	31.58	30.17	29.03	28.08	26.55
9.5	49.17	41.35	37.36	34.77	32.89	31.42	30.23	29.24	27.65
10.0	51.10	42.97	38.83	36.14	34.17	32.65	31.42	30.39	28.74
10.5	53.01	44.57	40.28	37.48	35.45	33.87	32.59	31.52	29.81
11.0	54.89	46.16	41.71	38.81	36.71	35.07	33.75	32.64	30.87
11.5	56.75	47.72	43.12	40.13	37.95	36.26	34.89	33.74	31.91
12.0	58.59	49.27	44.52	41.43	39.18	37.44	36.02	34.84	32.95
12.5	60.41	50.80	45.90	42.72	40.40	38.60	37.14	35.92	33.97
13.0	62.22	52.32	47.27	43.99	41.61	39.75	38.25	36.99	34.99
13.5	64.00	53.82	48.63	45.26	42.80	40.89	39.35	38.06	35.99
14.0	65.77	55.31	49.98	46.51	43.98	42.02	40.44	39.11	36.99
14.5	67.53	56.78	51.31	47.75	45.16	43.15	41.51	40.15	37.97
15.0	69.27	58.25	52.63	48.98	46.32	44.26	42.58	41.19	38.95
15.5	70.99	59.70	53.94	50.20	47.47	45.36	43.64	42.21	39.92
16.0	72.70	61.13	55.24	51.41	48.62	46.45	44.70	43.23	40.88
16.5	74.40	62.56	56.53	52.61	49.75	47.54	45.74	44.24	41.84
17.0	76.08	63.98	57.81	53.80	50.88	48.61	46.77	45.24	42.78
17.5	77.75	65.38	59.48	54.98	52.00	49.68	47.80	46.23	43.72
18.0	79.41	66.78	60.35	56.16	53.11	50.74	48.82	47.22	44.66
19.0	82.70	69.54	62.84	58.48	55.31	52.84	50.84	49.17	46.51
20.0	85.95	72.27	65.30	60.77	57.47	54.92	52.84	51.10	48.33
21.0	89.15	74.97	67.74	63.04	59.62	56.96	54.81	53.01	50.13
22.0	92.31	77.63	70.14	65.28	61.73	58.98	56.75	54.89	51.91
23.0	95.44	80.26	72.52	67.49	63.83	60.98	58.68	56.75	53.67
24.0	98.54	82.86	74.87	69.68	65.90	62.96	60.58	58.59	55.41

7.8.1 RADIUS OF RELATIVE STIFFNESS (REFERENCE: PORTLAND CEMENT ASSOCIATION)

NOTE: EQUIVALENT SINGLE WHEEL LOADS ARE DERIVED BY METHODS SHOWN IN ICAO AERODROME MANUAL, PART 2, PARA 4.1.3

LCN REQUIREMENTS ARE BASED ON CENTER OF SLAB LOADING

44 x 16 TIRES
TIRE PRESSURE CONSTANT AT 177 PSI

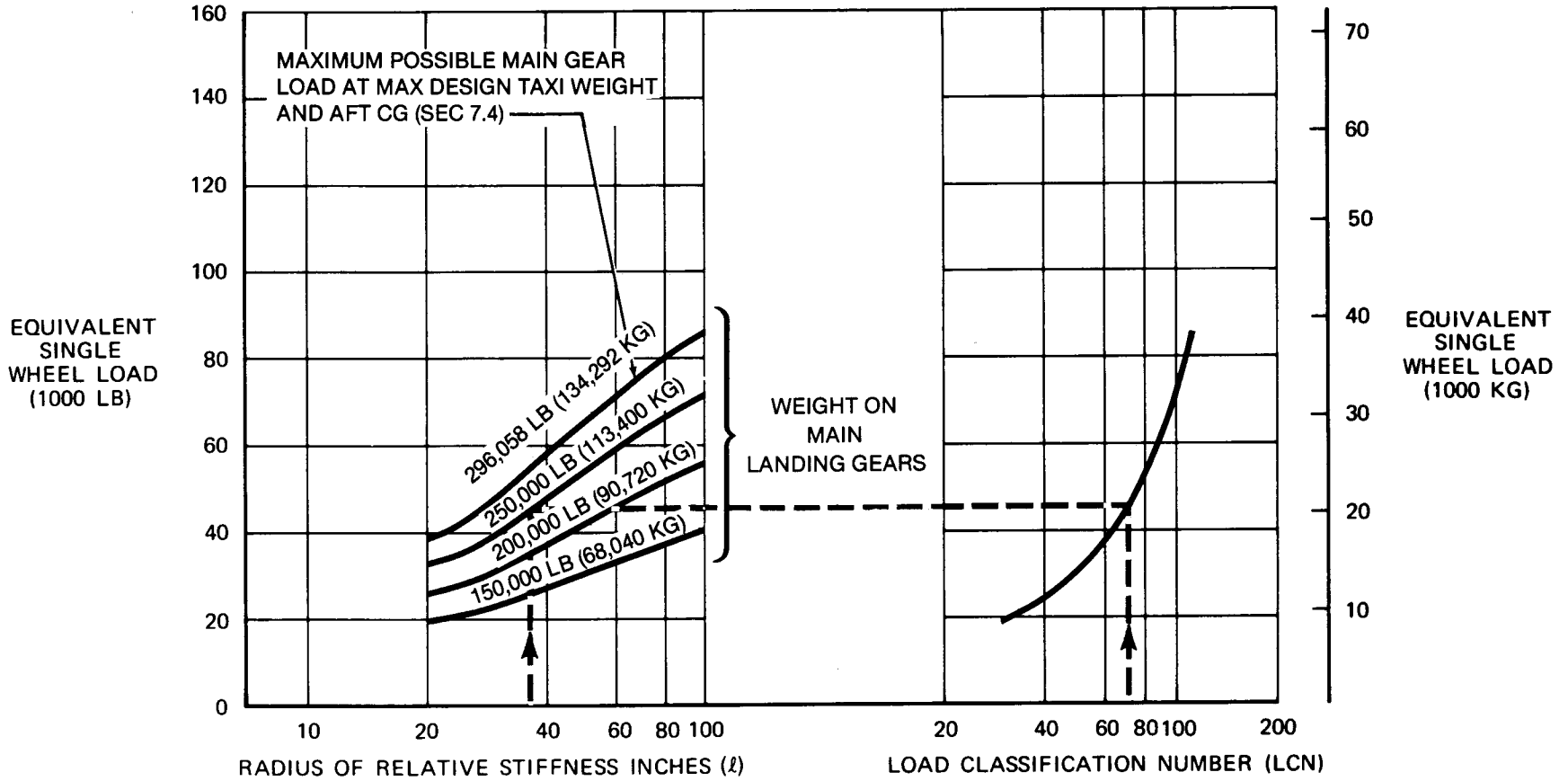

7.8.2 RIGID PAVEMENT REQUIREMENTS, LCN CONVERSION MODEL DC-8-43

NOTE: EQUIVALENT SINGLE WHEEL LOADS ARE DERIVED BY METHODS SHOWN IN ICAO AERODROME MANUAL, PART 2, PARA 4.1.3

LCN REQUIREMENTS ARE BASED ON CENTER OF SLAB LOADING

44 x 16 TIRES
TIRE PRESSURE CONSTANT AT 186 PSI

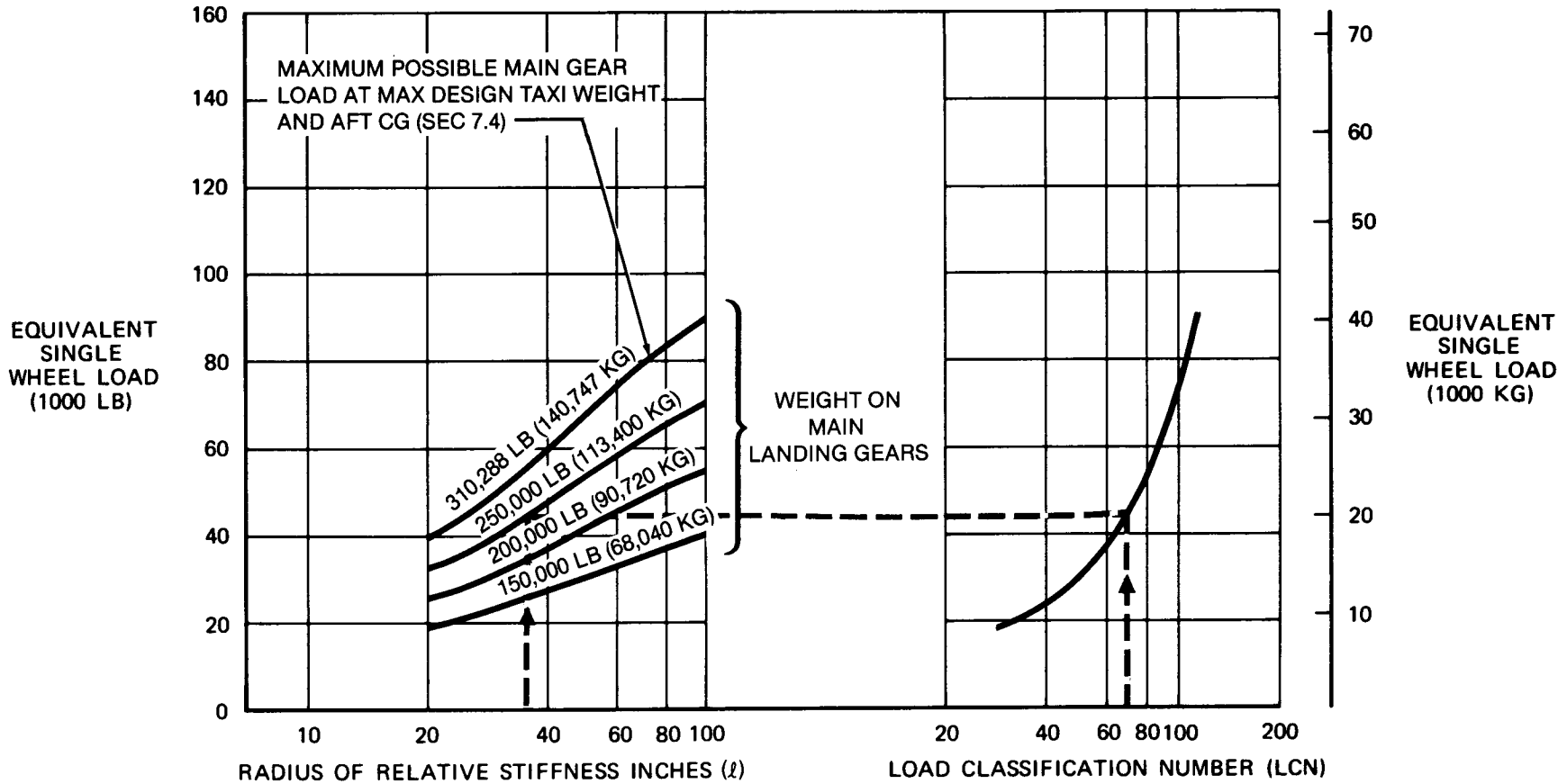

7.8.2 RIGID PAVEMENT REQUIREMENTS, LCN CONVERSION MODEL DC-8-55

NOTE: EQUIVALENT SINGLE WHEEL LOADS ARE DERIVED BY METHODS SHOWN IN ICAO AERODROME MANUAL, PART 2, PARA 4.1.3

LCN REQUIREMENTS ARE BASED ON CENTER OF SLAB LOADING

44 x 16 TIRES
TIRE PRESSURE CONSTANT AT 186 PSI

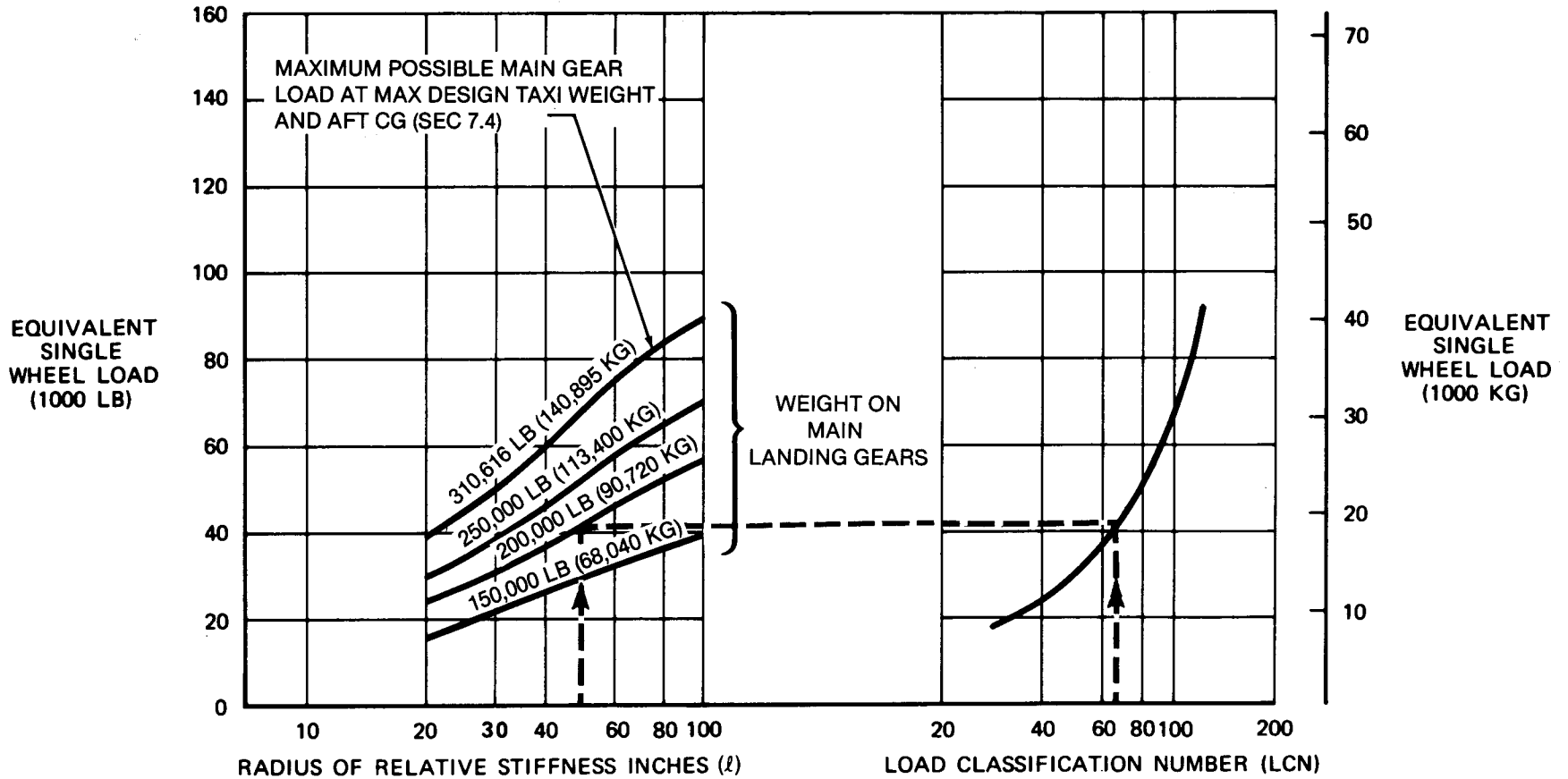

7.8.2 RIGID PAVEMENT REQUIREMENTS, LCN CONVERSION MODEL DC-8-55F

NOTE: EQUIVALENT SINGLE WHEEL LOADS ARE DERIVED BY METHODS SHOWN IN ICAO AERODROME MANUAL, PART 2, PARA 4.1.3

LCN REQUIREMENTS ARE BASED ON CENTER OF SLAB LOADING

44 x 16 TIRES
TIRE PRESSURE CONSTANT AT 188 PSI

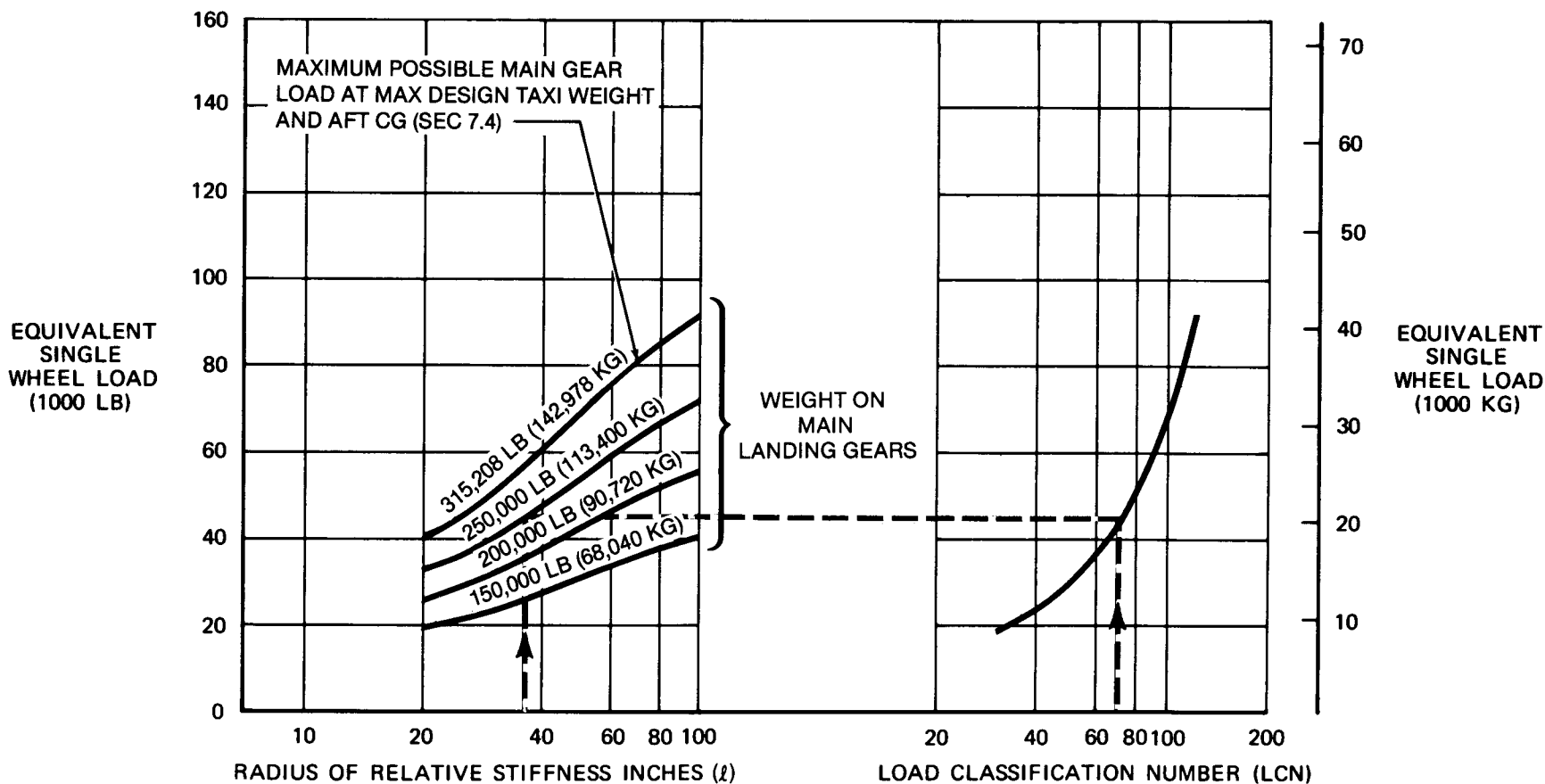

7.8.2 RIGID PAVEMENT REQUIREMENTS LCN CONVERSION MODEL DC-8-61, -71

NOTE: EQUIVALENT SINGLE WHEEL LOADS ARE DERIVED BY METHODS SHOWN IN ICAO AERODROME MANUAL, PART 2, PARA 4.1.3

LCN REQUIREMENTS ARE BASED ON CENTER OF SLAB LOADING

44 x 16 TIRES
TIRE PRESSURE CONSTANT AT 190 PSI

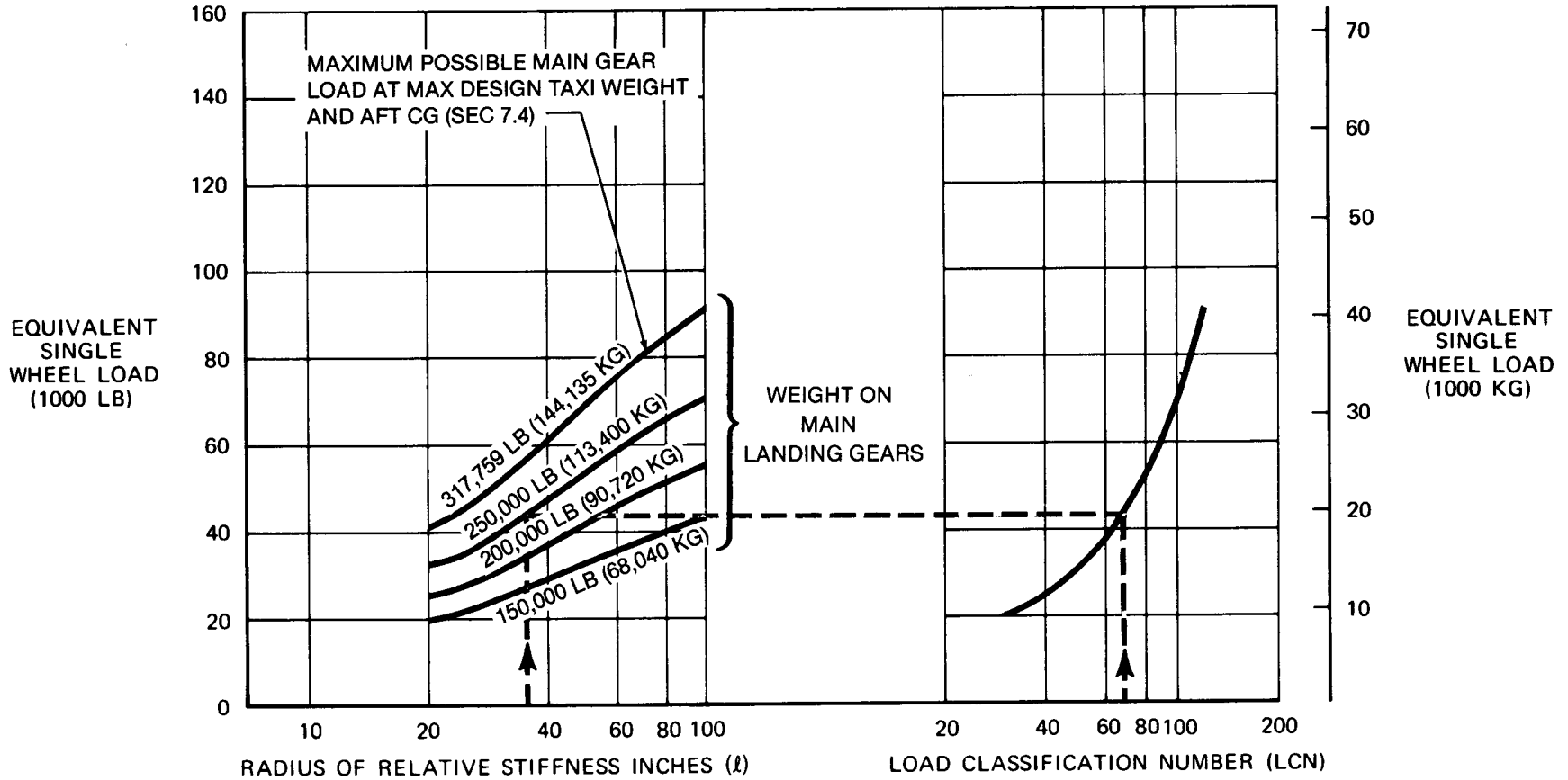

7.8.2 RIGID PAVEMENT REQUIREMENTS LCN CONVERSION MODEL DC-8-61F, -71F

NOTE: EQUIVALENT SINGLE WHEEL LOADS ARE DERIVED BY METHODS SHOWN IN ICAO AERODROME MANUAL, PART 2, PARA 4.1.3

LCN REQUIREMENTS ARE BASED ON CENTER OF SLAB LOADING

44.5 x 16.5 - 18 TIRES
TIRE PRESSURE CONSTANT AT 191 PSI

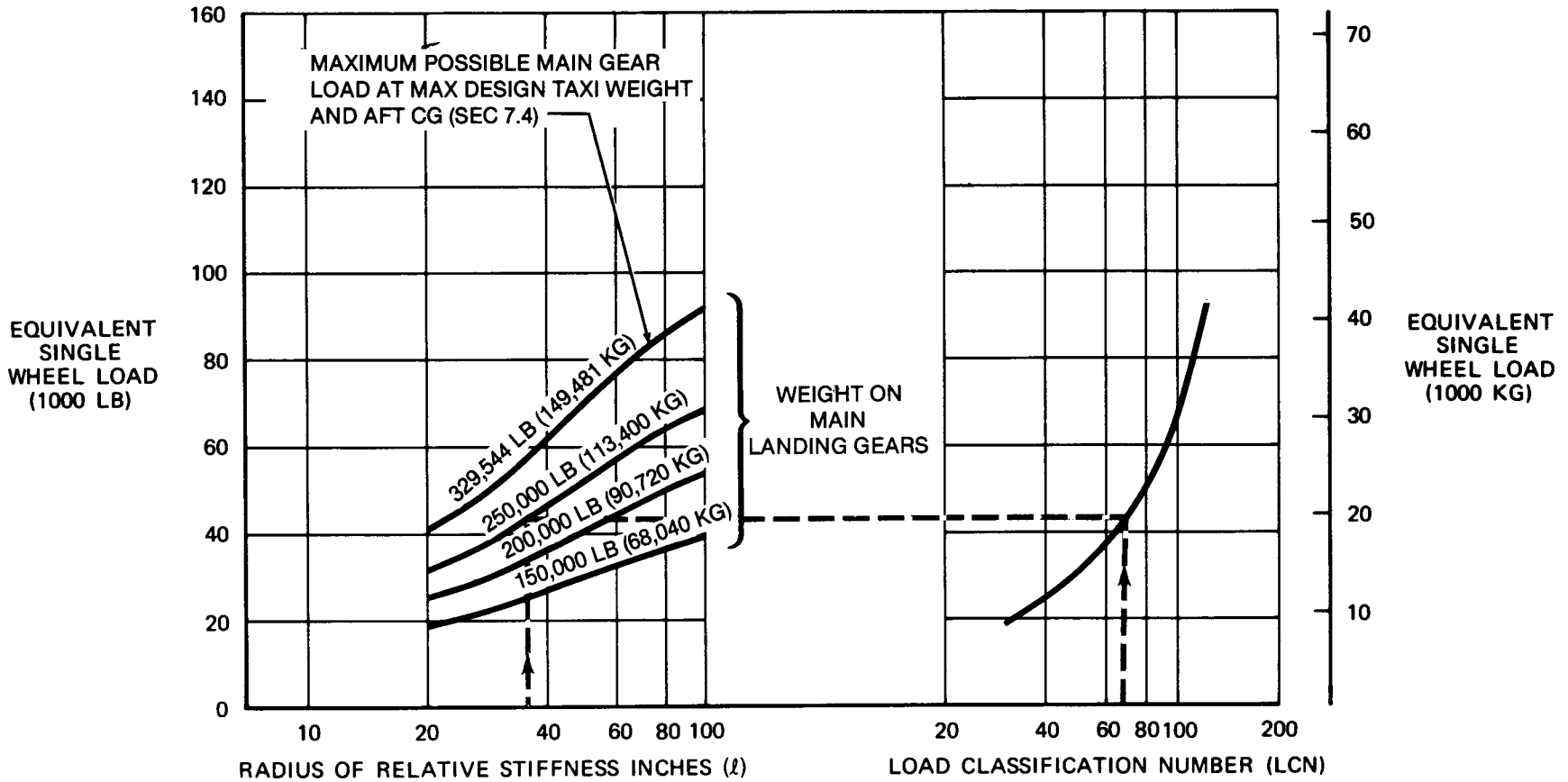

7.8.2 RIGID PAVEMENT REQUIREMENTS LCN CONVERSION MODEL DC-8-62, -72

NOTE: EQUIVALENT SINGLE WHEEL LOADS ARE DERIVED BY METHODS SHOWN IN ICAO AERODROME MANUAL, PART 2, PARA 4.1.3

LCN REQUIREMENTS ARE BASED ON CENTER OF SLAB LOADING

44.5 x 16.5 - 18 TIRES
TIRE PRESSURE CONSTANT AT 191 PSI

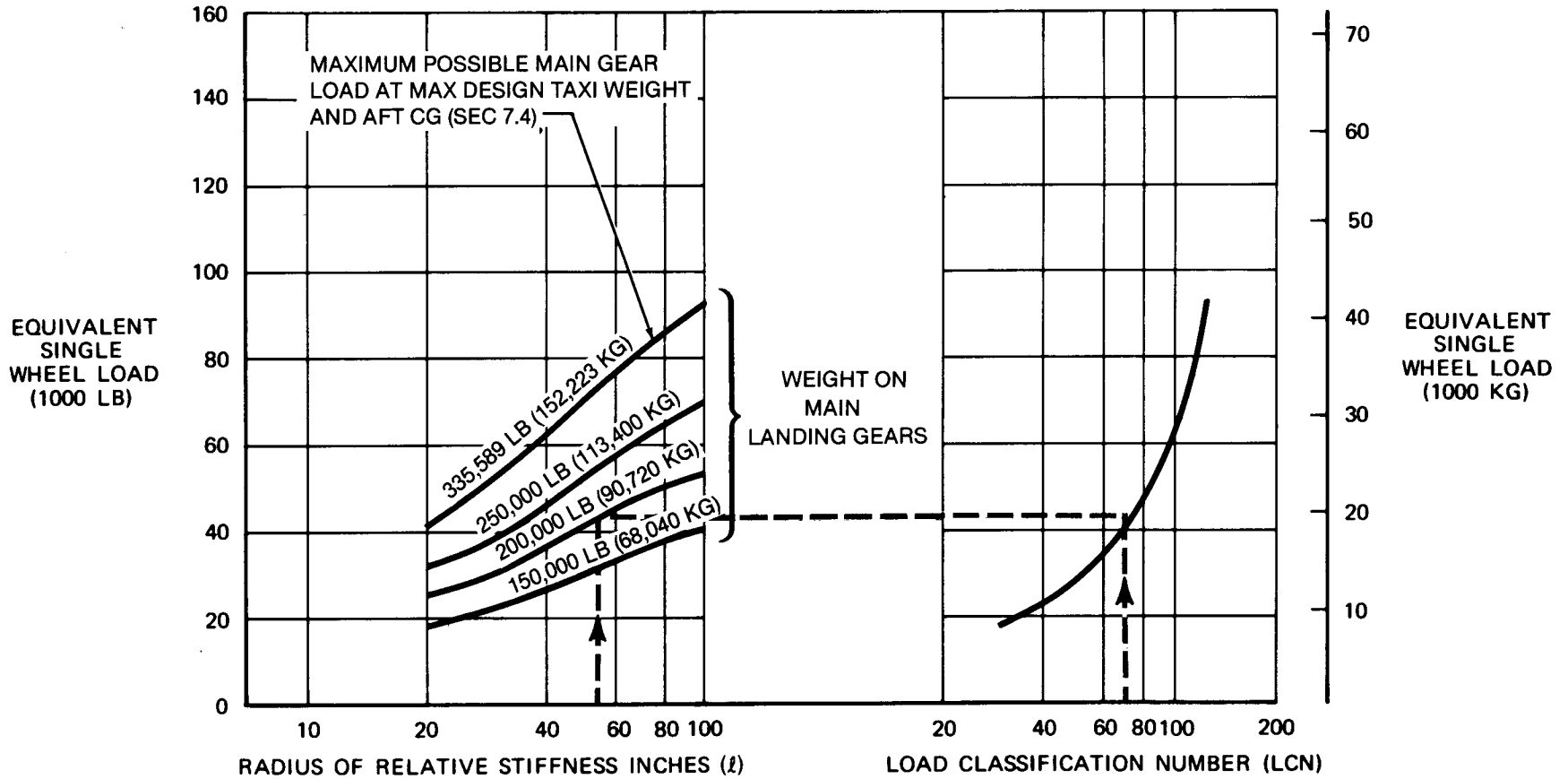

7.8.2 RIGID PAVEMENT REQUIREMENTS LCN CONVERSION MODEL DC-8-62F, -72F

NOTE: EQUIVALENT SINGLE WHEEL LOADS ARE DERIVED BY METHODS SHOWN IN ICAO AERODROME MANUAL, PART 2, PARA 4.1.3

LCN REQUIREMENTS ARE BASED ON CENTER OF SLAB LOADING

44.5 x 16.5 - 18 TIRES
TIRE PRESSURE CONSTANT AT 196 PSI

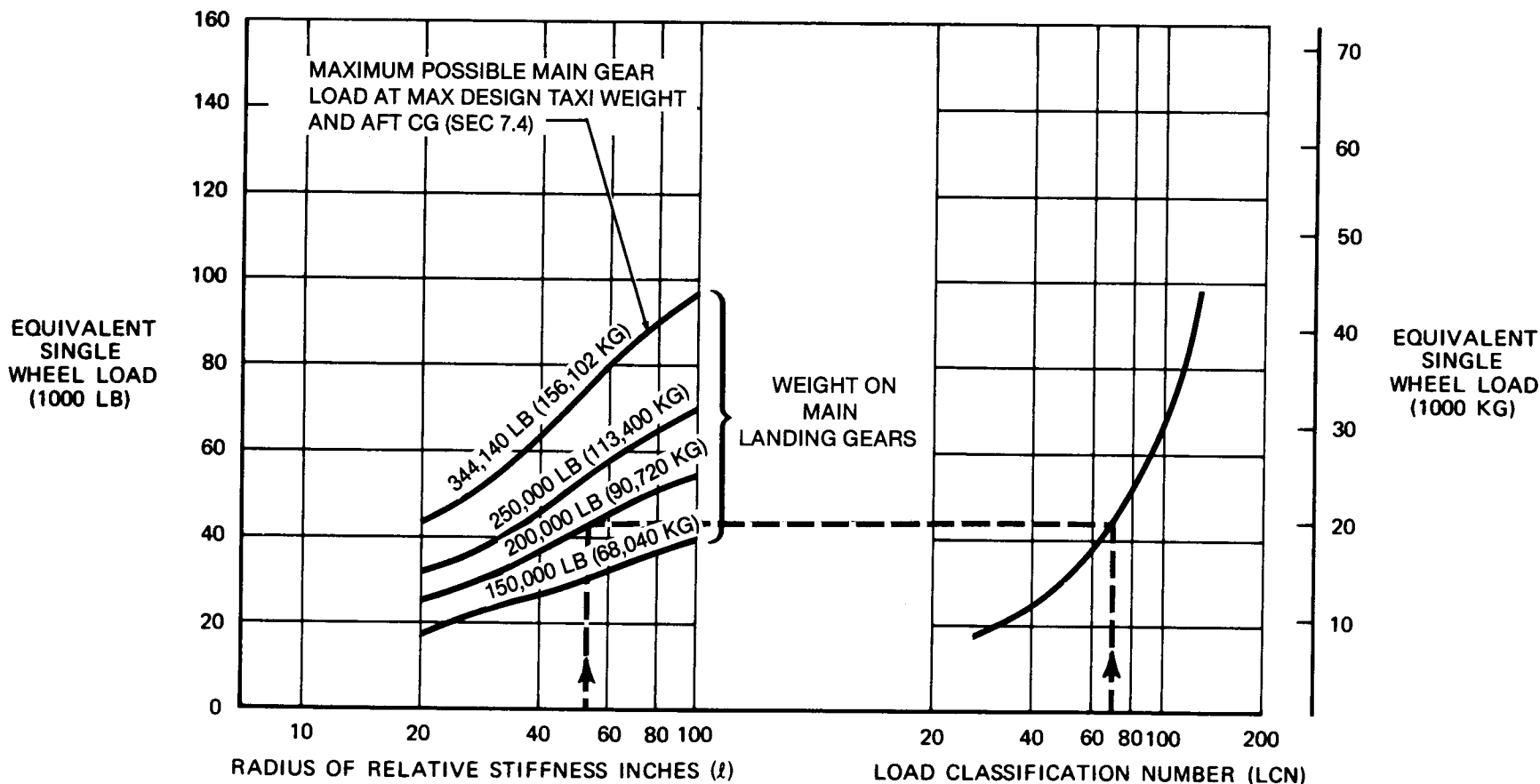

7.8.2 RIGID PAVEMENT REQUIREMENTS LCN CONVERSION MODEL DC-8-63, -73

NOTE: EQUIVALENT SINGLE WHEEL LOADS ARE DERIVED BY METHODS SHOWN IN ICAO AERODROME MANUAL, PART 2, PARA 4.1.3

LCN REQUIREMENTS ARE BASED ON CENTER OF SLAB LOADING

44.5 x 16.5 TIRES
TIRE PRESSURE CONSTANT AT 196 PSI

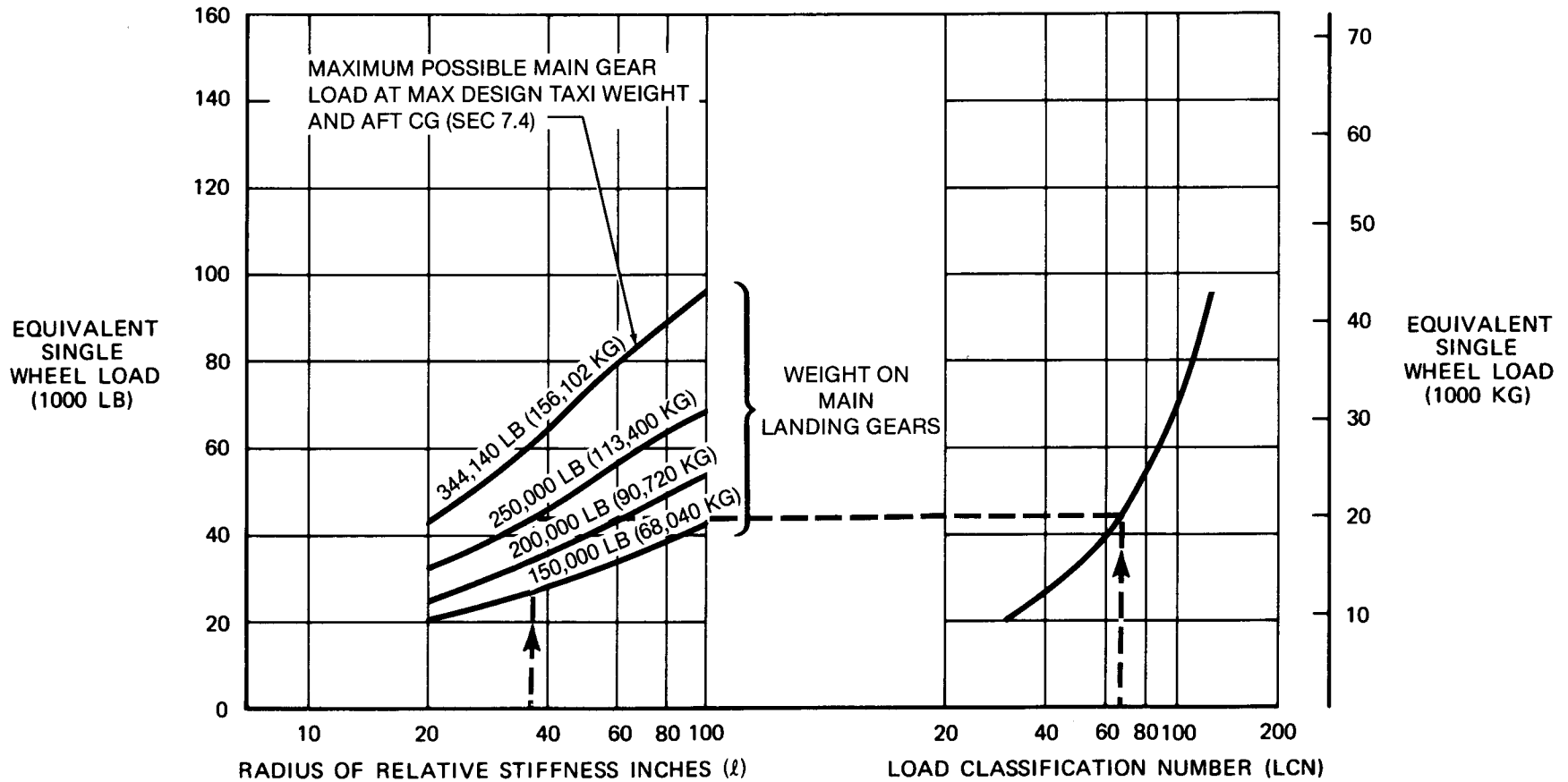

7.8.2 RIGID PAVEMENT REQUIREMENTS LCN CONVERSION MODEL DC-8-63F, -73F

7.8.3 Radius of Relative Stiffness (Other values of E and ℓ)

The chart of Section 7.8.1 presents ℓ -values based on Young's Modulus (E) of 4,000,000 psi and Poisson's Ratio (μ) of 0.15. For convenience in finding ℓ -values based on other values of E and μ , the curves of Section 7.8.3 are included. For example, to find an ℓ -value based on an E of 3,000,000 psi, the "E" factor of 0.931 is multiplied by the ℓ -value found in the table of Section 7.8.1. The effect of variations of μ and the ℓ -value is treated in a similar manner.

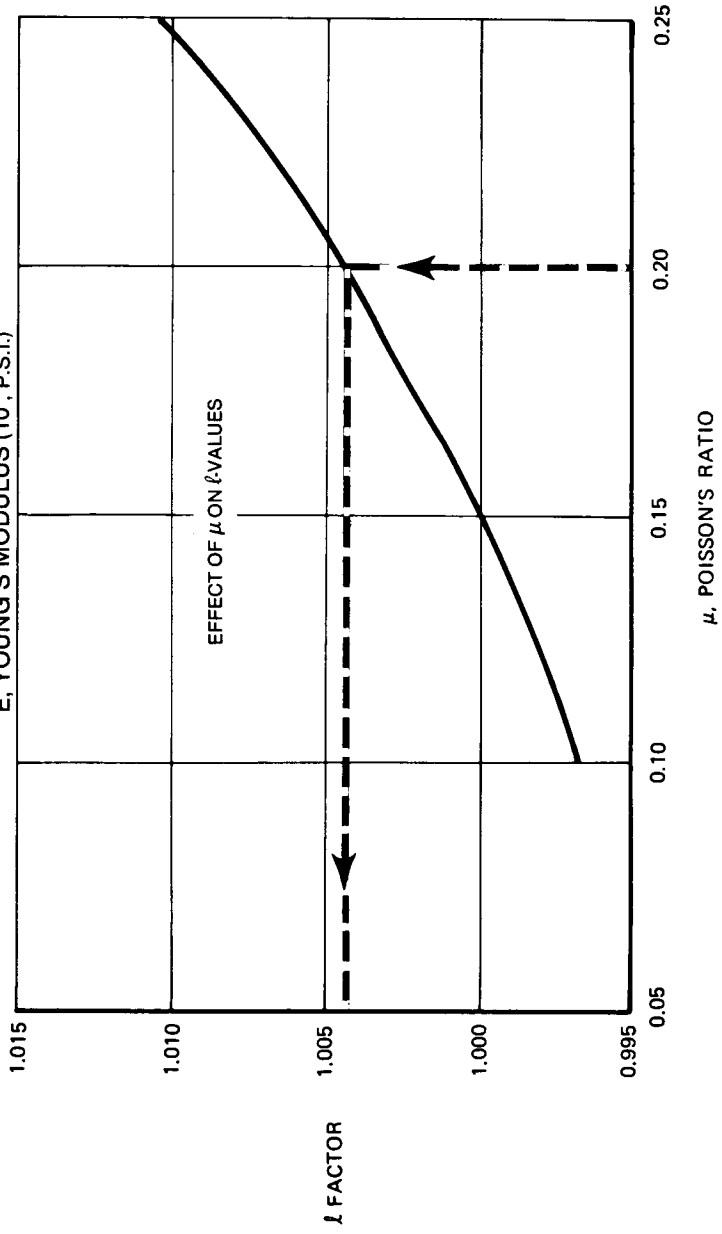
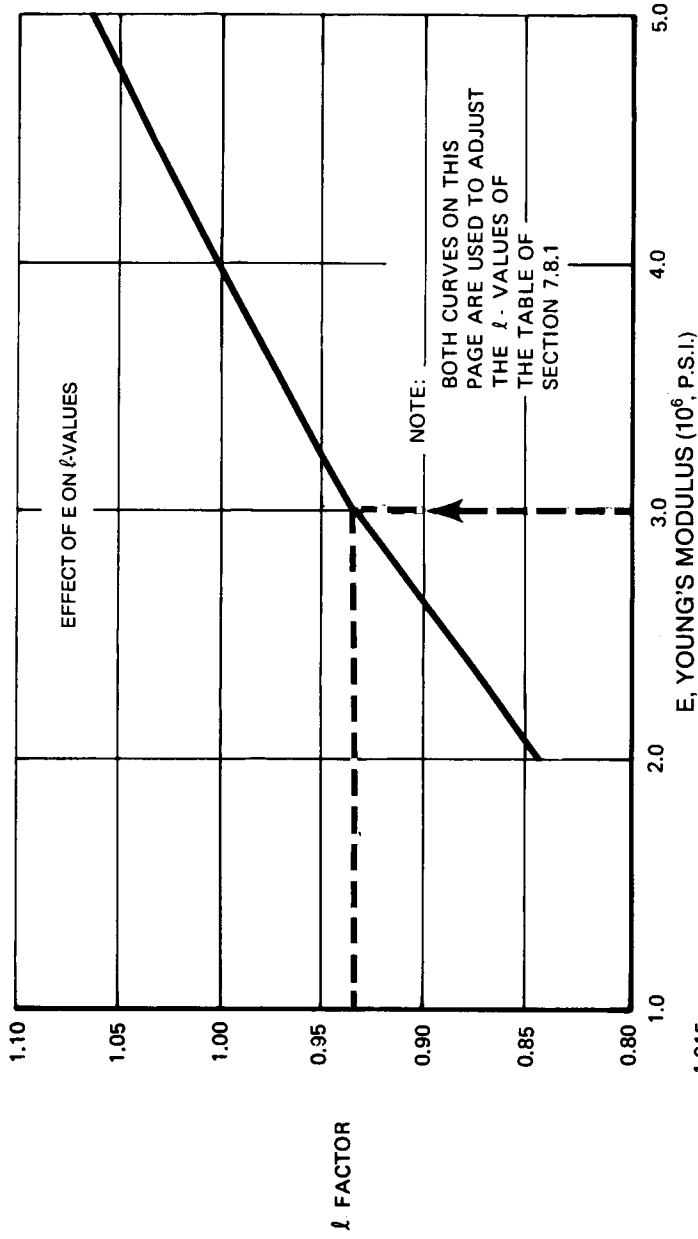

7.8.4 EFFECT ON RADIUS OF RELATIVE STIFFNESS

7.9 ACN/PCN Reporting System - Flexible and Rigid Pavements

To determine the ACN of an aircraft on flexible or rigid pavement, both the aircraft gross weight and the subgrade strength category must be known. In the chart in 7.9.1, for an aircraft with gross weight of 300,000 lb on a (Code C), the flexible pavement ACN is 51. Referring to 7.9.2, the same aircraft on a low strength subgrade rigid pavement has an ACN of 54.4.

The following table provides ACN data in tabular format similar to the one used by ICAO in the “Aerodrome Design Manual Part 3, Pavements.” If the ACN for an intermediate weight between maximum taxi weight and minimum weight of the aircraft is required, Figures 7.9.1 through 7.9.2 should be consulted.

AIRCRAFT TYPE	MAXIMUM TAXI WEIGHT MINIMUM WEIGHT (1) LB (KG)	LOAD ON ONE MAIN GEAR LEG (%)	TIRE PRESSURE PSI (MPa)	ACN FOR RIGID PAVEMENT SUBGRADES – MN/m ³				ACN FOR FLEXIBLE PAVEMENT SUBGRADES – CBR			
				HIGH 150	MEDIUM 80	LOW 40	ULTRA LOW 20	HIGH 15	MEDIUM 10	LOW 6	ULTRA LOW 3
DC-8-63	358,000(162,386) 17,100(7,756)	--	182 (1.25)	48	55	66	81	51	60	69	78
				17	18	21	27	17	19	23	26

(1) Minimum weight used solely as a baseline for ACN curve generation.

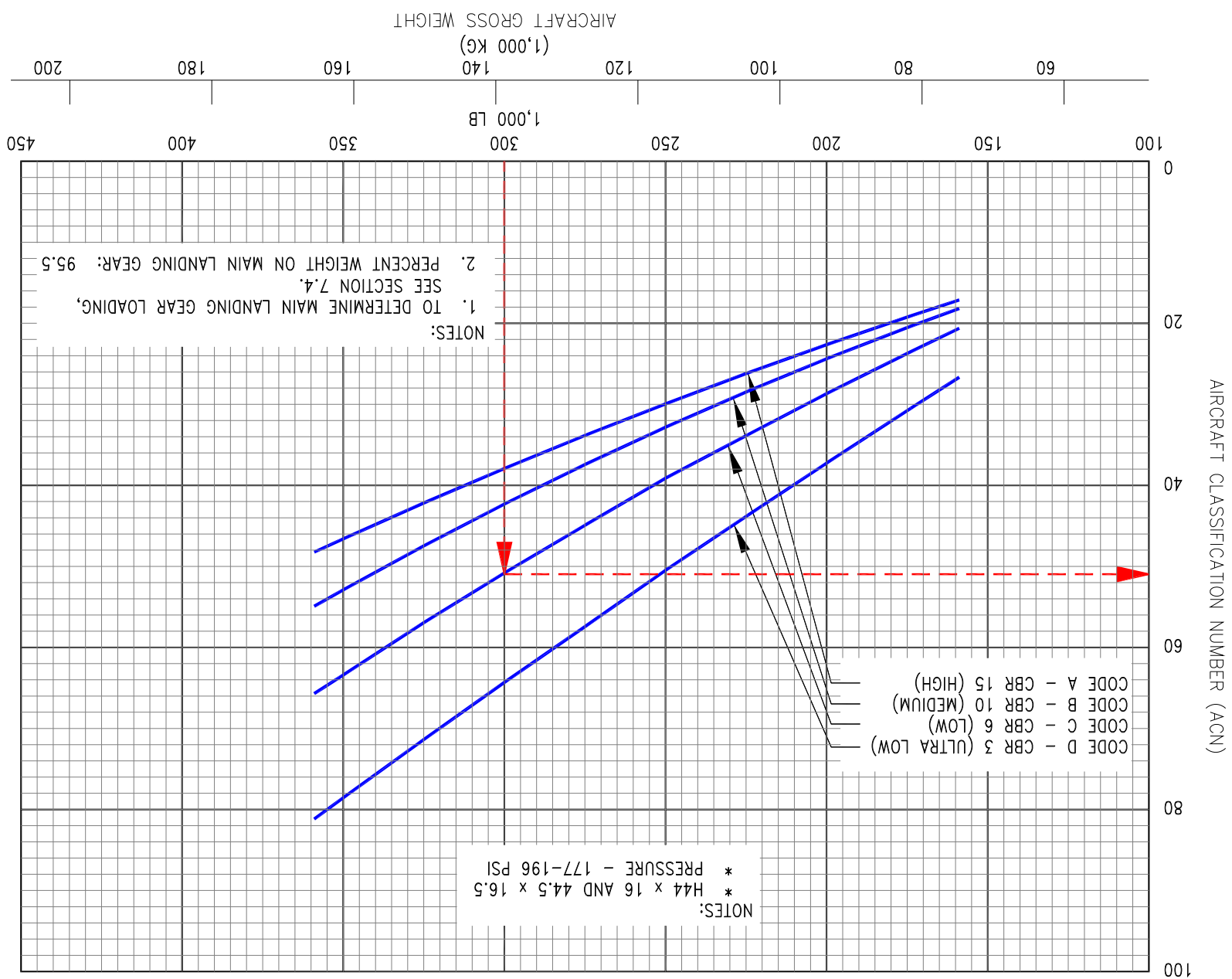

NOTES:
 1. TO DETERMINE MAIN LANDING GEAR LOADING,
 SEE SECTION 7.4.
 2. PERCENT WEIGHT ON MAIN LANDING GEAR: 95.5

NOTES:
 * H44 x 16 AND 44.5 x 16.5
 * PRESSURE - 177-196 PSI

7.9.1 AIRCRAFT CLASSIFICATION NUMBER - FLEXIBLE PAVEMENT
 MODEL DC-8: ALL SERIES

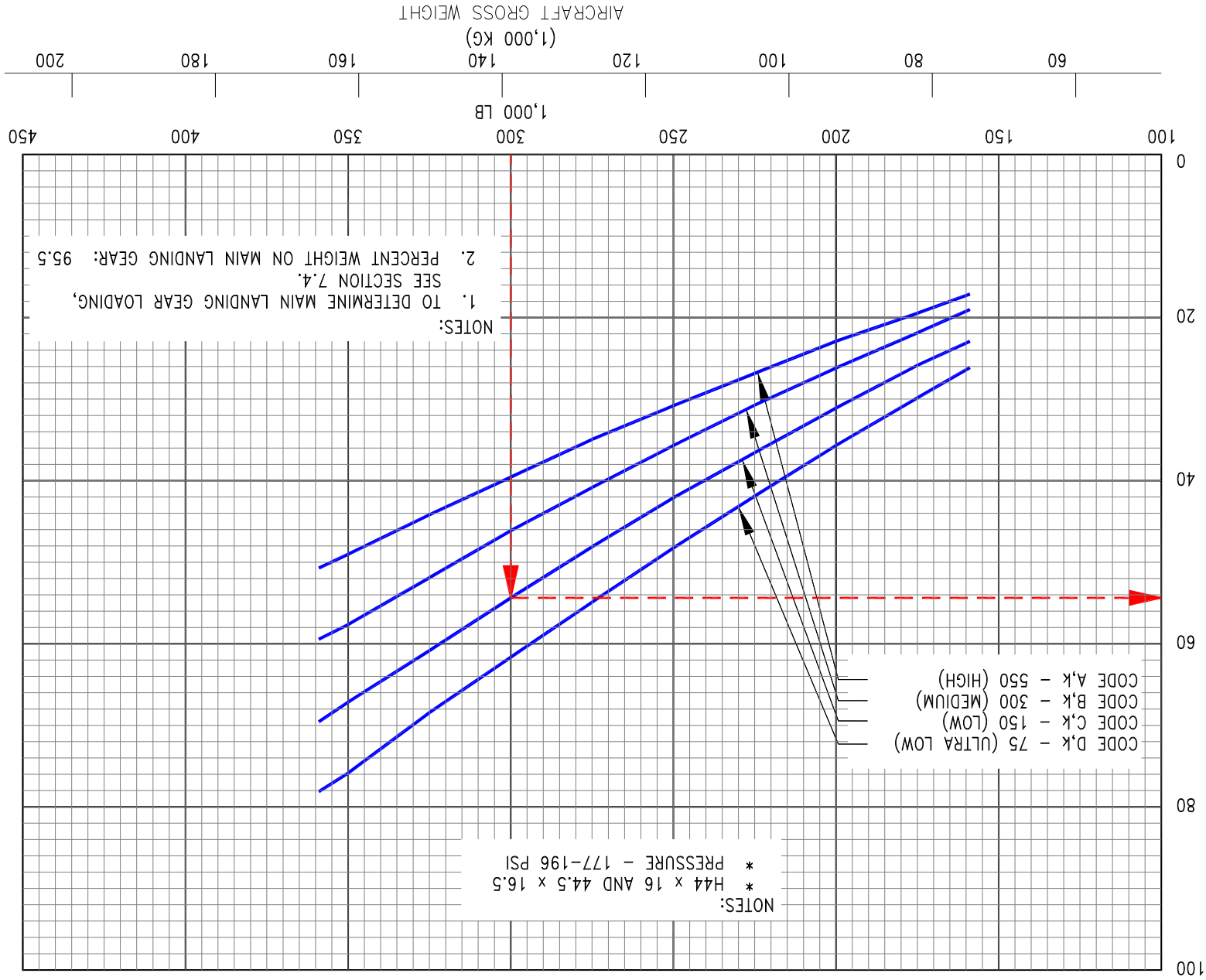

7.9.2 AIRCRAFT CLASSIFICATION NUMBER - RIGID PAVEMENT
 MODEL DC-8: ALL SERIES

7.9.3 Development of ACN Charts

The ACN charts for flexible and rigid pavements as shown on Pages 226 and 227, respectively, were developed by methods referenced in Amendment 35 to ICAO Annex 14. The procedures to develop these charts are also described below.

The following procedure is used to develop the flexible pavement ACN charts such as that shown on Page 226.

1. Determine the percent of weight on the main gear to be used in Steps 2, 3, and 4 below. It is the maximum aft c.g. position which yields the critical loading on the critical gear (see Pages 183 through 191). This c.g. position is used to determine main gear loads at all gross weights of the model being considered.
2. Establish a flexible pavement requirements chart using the S-77-1 design method such as shown on the right-hand side of Page 229. Use standard subgrade strengths of CBR 3, 5, 10, and 15 percent and 10,000 coverages. This chart provides the same thickness values as that of Page 192, but is presented here in different formats.
3. Determine reference thickness values from the pavement requirements chart of Step 2 for each standard subgrade strength and gear loading.
4. Enter the reference thickness values into the ACN Flexible Pavement Conversion Chart shown on the left-hand side of Page 229 to determine ACN. This chart was developed using the S-77-1 design method with a single tire inflated to 1.25 MPa (181 psi) pressure and 10,000 coverages. The ACN is two times the derived single wheel load expressed in thousands of kilograms. These values of ACN are then plotted as a function of aircraft gross weight such as shown on Page 226.

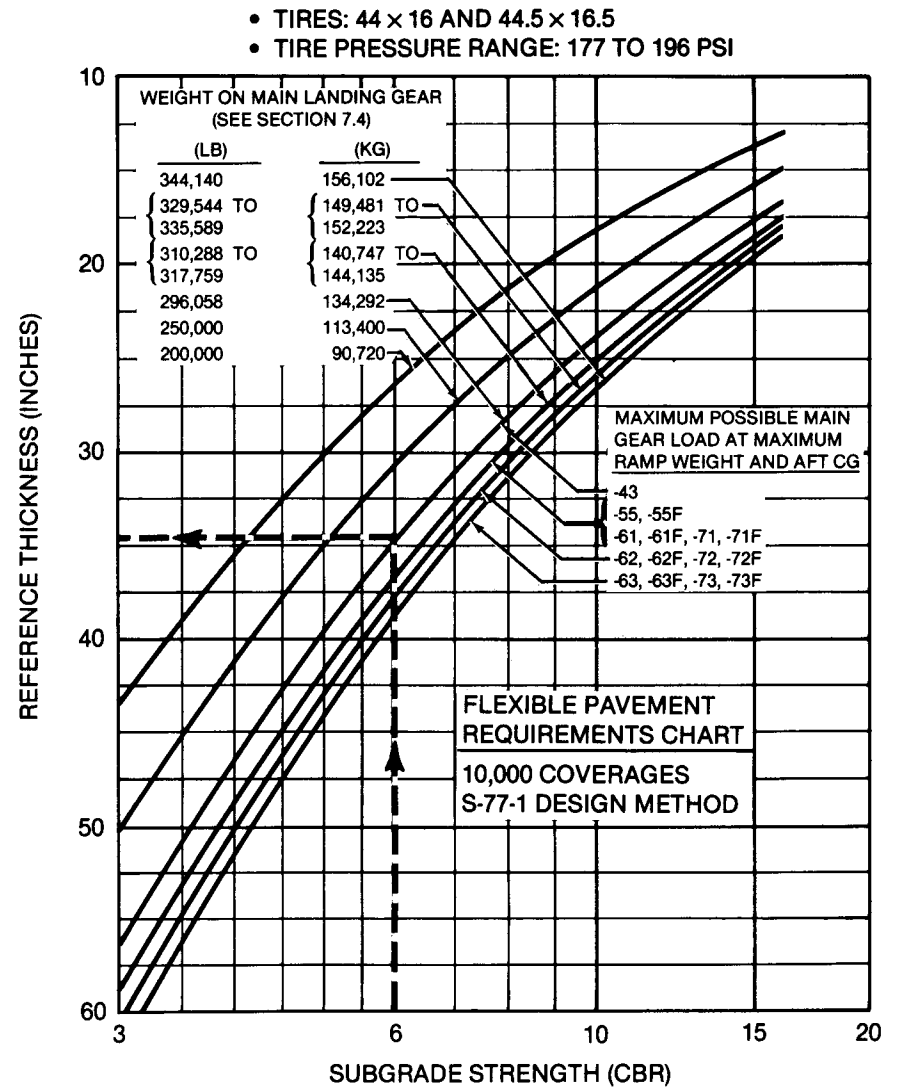
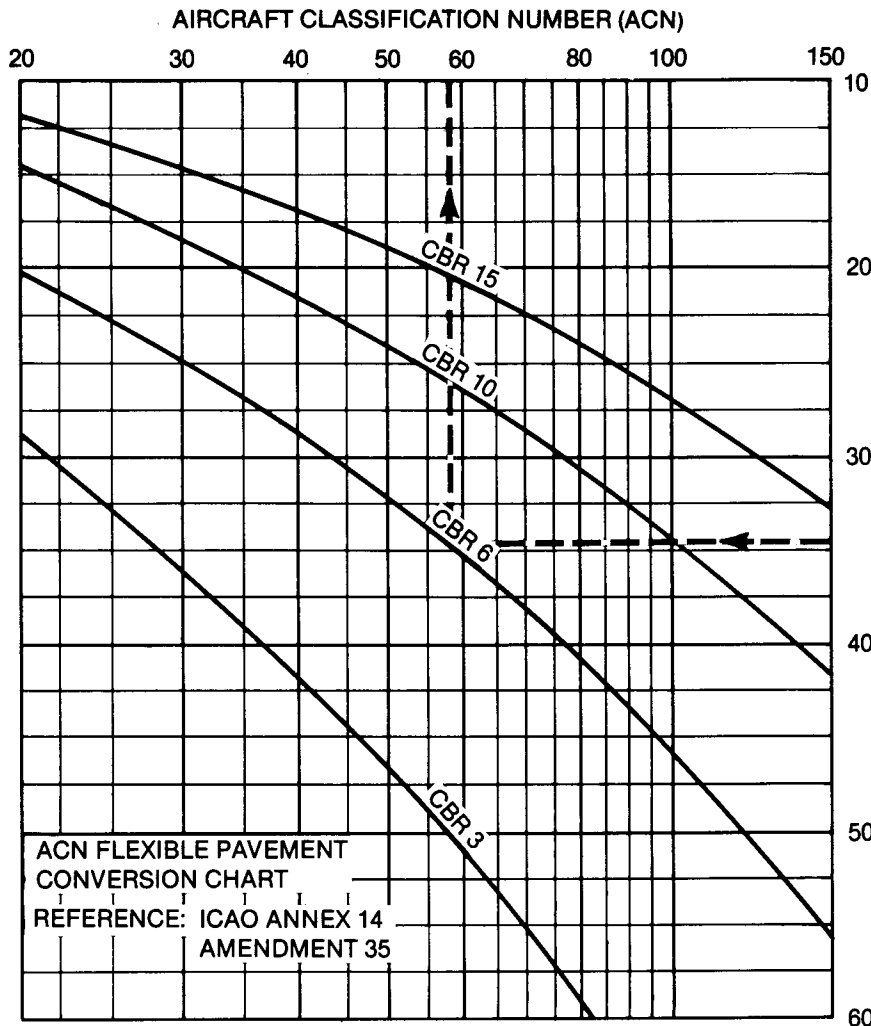

7.9.4 DEVELOPMENT OF AIRCRAFT CLASSIFICATION NUMBER (ACN) — FLEXIBLE PAVEMENT

The following procedure is used to develop the rigid pavement ACN charts such as that shown on Page 227.

1. Determine the percent of weight on the main gear to be used in Steps 2, 3, and 4 below. It is the maximum aft c.g. position which yields the critical loading on the critical gear (see Pages 183 through 191). This c.g. position is used to determine main gear loads at all gross weights of the model being considered.
2. Establish a rigid pavement requirements chart using the PCA computer program PDILB such as shown on the right-hand side of Page 231. Use standard subgrade strengths of $k = 75, 150, 300,$ and 550 pci (nominal values for $k = 20, 40, 80, 150$ MN/m³). This chart provides the same thickness values as that of Pages 203 through 211.
3. Determine reference thickness values from the pavement requirements chart of Step 2 for each standard subgrade strength and gear loading at 400 psi working stress (nominal value for 2.75 MPa working stress).
4. Enter the reference thickness values in the ACN Rigid Pavement Conversion Chart shown on the left-hand side of Page 231 to determine ACN. This chart was developed using the PCA computer program PDILB with a single tire inflated to 1.25 MPa (181 psi) pressure and a working stress of 400 psi. The ACN is two times the derived single wheel load expressed in thousands of kilograms. These values of ACN are then plotted as a function of aircraft gross weight such as shown on Page 227.

AIRCRAFT CLASSIFICATION NUMBER (ACN)

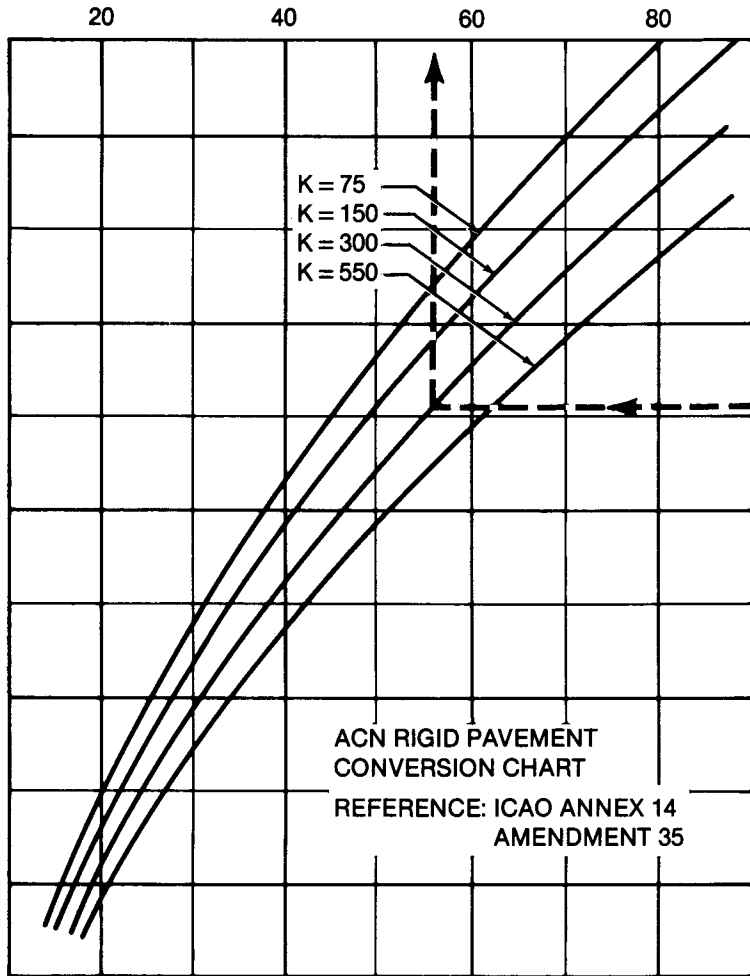

NOTE:

- TIRES: 44 × 16 AND 44.5 × 16.5
- TIRE PRESSURE RANGE: 177 TO 196 PSI

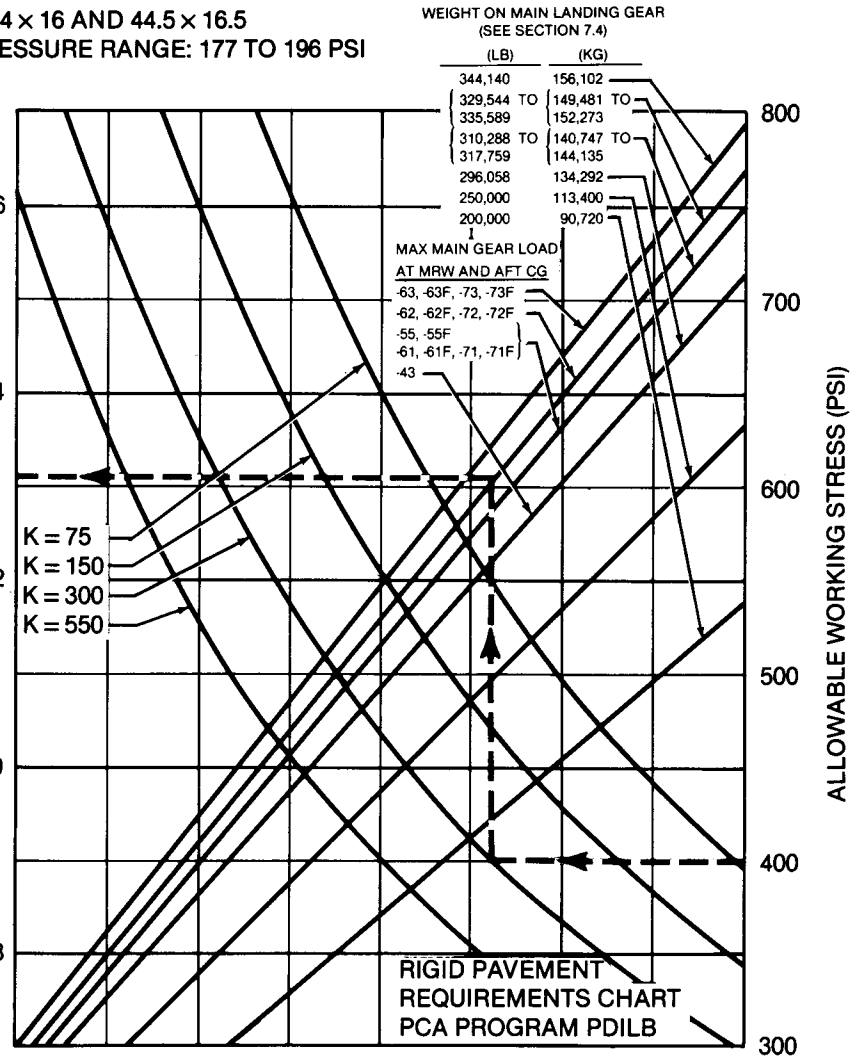

7.9.5 DEVELOPMENT OF AIRCRAFT CLASSIFICATION NUMBER (ACN) — RIGID PAVEMENT

8.0 POSSIBLE DC-8 DERIVATIVE AIRPLANES

No derivative versions of the DC-8 are currently planned.

SCALE: 1 IN. = 32 FT

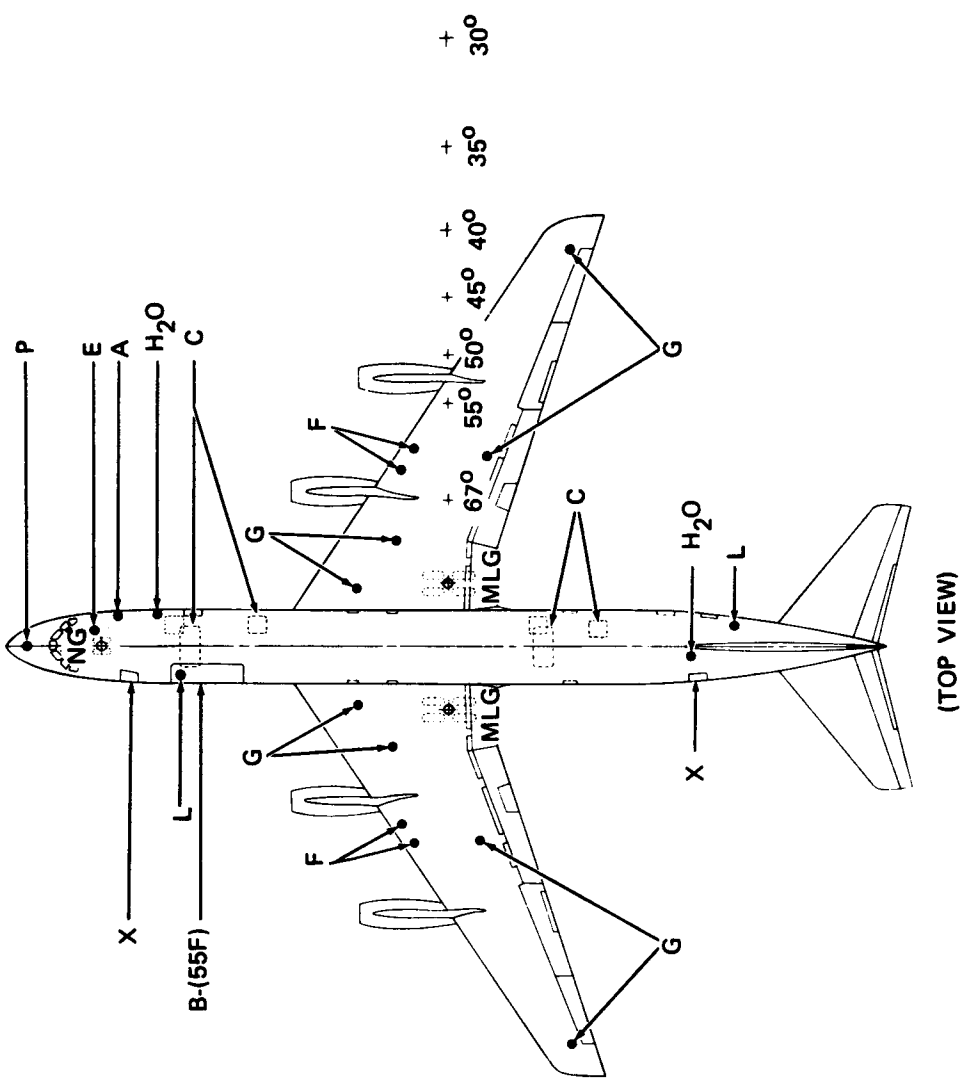

(TOP VIEW)

LEGEND

- | | | | |
|------------------|-------------------------------|-----|-------------------|
| A. | PRECONDITIONED AIR | L. | LAVATORY |
| B. | MAIN CARGO DOOR | MLG | MAIN LANDING GEAR |
| C. | FWD, AFT CARGO DOORS | NG | NOSE LANDING GEAR |
| E. | ELECTRICAL - GROUND POWER | P. | PNEUMATIC POWER |
| F. | PRESSURE REFUELING POINTS (4) | X. | PASSENGER DOOR |
| G. | GRAVITY REFUELING POINTS (6) | | |
| H ₂ O | POTABLE WATER (2) | | |
- TURNING RADIUS POINTS, 67°, 55°, 50°, 45°, 40°, 35°, 30°

9.0 SCALE DRAWINGS
MODEL DC-8-43, -55, -55F

SCALE: 1 IN. = 50 FT

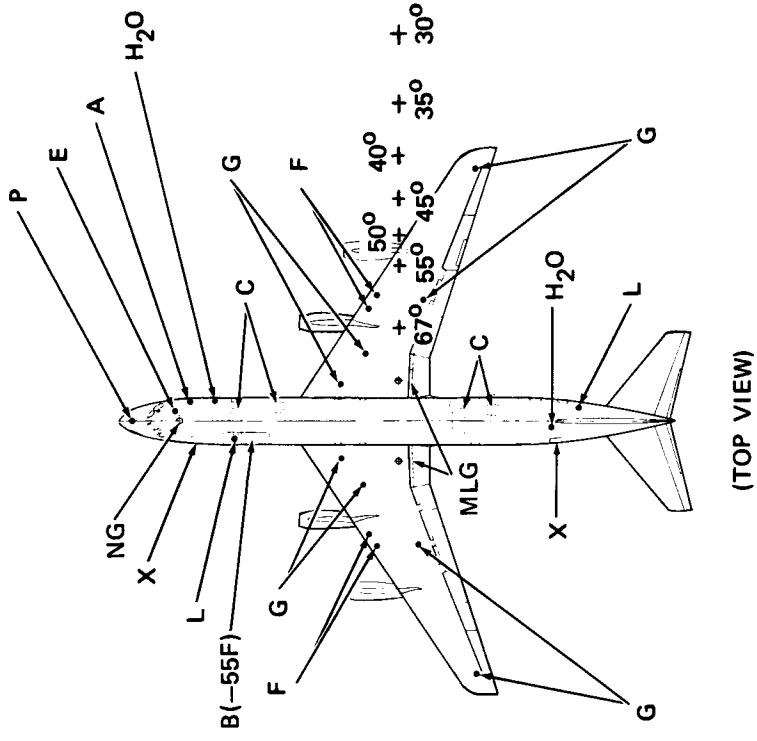

LEGEND

- | | | | |
|------------------|-------------------------------|-----|--|
| A. | PRECONDITIONED AIR | L. | LAVATORY |
| B. | MAIN CARGO DOOR | MLG | MAIN LANDING GEAR |
| C. | FWD, AFT CARGO DOORS | NG | NOSE LANDING GEAR |
| E. | ELECTRICAL - GROUND POWER | P. | PNEUMATIC POWER |
| F. | PRESSURE REFUELING POINTS (4) | X. | PASSENGER DOOR |
| G. | GRAVITY REFUELING POINTS (6) | | |
| H ₂ O | POTABLE WATER (2) | | |
| | | | TURNING RADIUS POINTS, 67°, 55°, 50°, 45°, 40°, 35°, 30° |

9.0 SCALE DRAWINGS
MODEL DC-8-43, -55, -55F

SCALE: 1 IN. = 100 FT

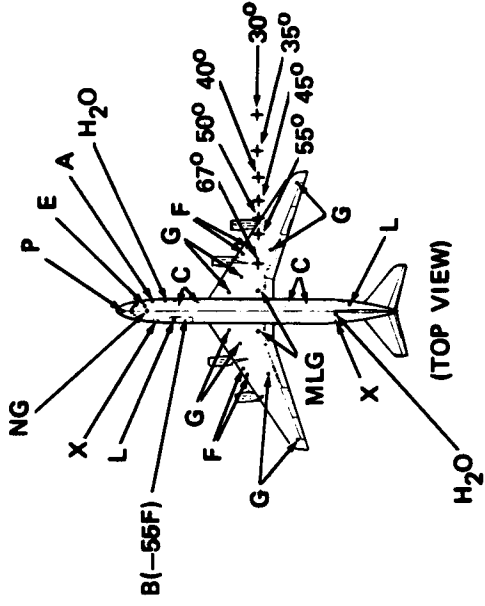

LEGEND

- | | | | |
|------------------|-------------------------------|-----|-------------------|
| A. | PRECONDITIONED AIR | L. | LAVATORY |
| B. | MAIN CARGO DOOR | MLG | MAIN LANDING GEAR |
| C. | FWD, AFT CARGO DOORS | NG | NOSE LANDING GEAR |
| E. | ELECTRICAL - GROUND POWER | P. | PNEUMATIC POWER |
| F. | PRESSURE REFUELING POINTS (4) | X. | PASSENGER DOOR |
| G. | GRAVITY REFUELING POINTS (6) | | |
| H ₂ O | POTABLE WATER (2) | | |
- TURNING RADIUS POINTS, 67°, 55°, 50°, 45°, 40°, 35°, 30°

9.0 SCALE DRAWINGS
MODEL DC-8-43, -55, -55F

SCALE: 1 IN. = 32 FT

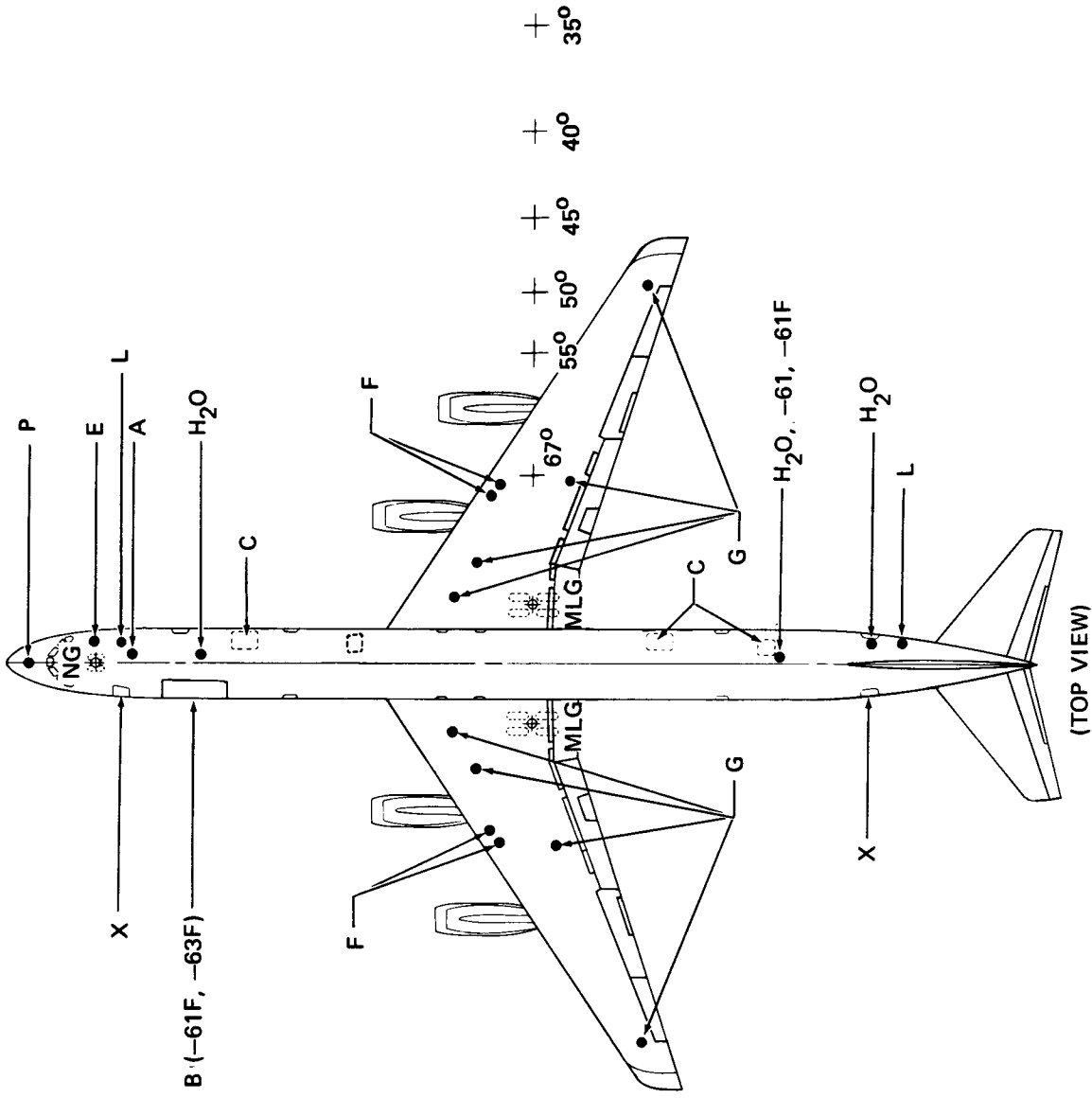

B (-61F, -63F)

- | | |
|---|--|
| <p>A. PRE-CONDITIONED AIR
 B. MAIN CARGO DOOR
 C. FWD, AFT CARGO DOORS
 E. ELECTRICAL - GROUND POWER
 F. PRESSURE REFUELING POINTS (4)
 G. GRAVITY REFUELING POINTS (8)
 H₂O POTABLE WATER</p> | <p>L LAVATORY
 MLG MAINLANDING GEAR
 NG NOSE GEAR
 P PNEUMATIC
 X PASSENGER DOOR
 TURNING RADIUS POINTS, 67°
 55°, 50° 45°, 40° 35°, 30°</p> |
|---|--|

LEGEND

9.0 SCALE DRAWINGS
 MODEL DC-8-61, -61F, -63, -63F, -71, -71F, -73, -73F

SCALE: 1 IN. = 50 FT

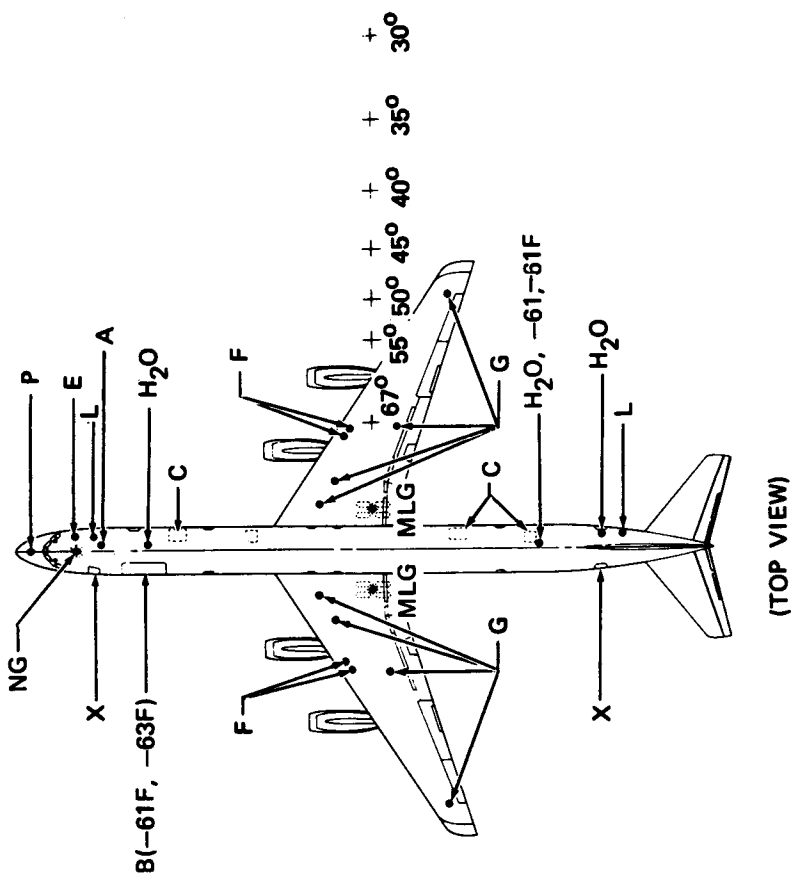

LEGEND

- | | | | |
|------------------|-------------------------------|-----|-------------------|
| A. | PRECONDITIONED AIR | L. | LAVATORY |
| B. | MAIN CARGO DOOR | MLG | MAIN LANDING GEAR |
| C. | FWD, AFT CARGO DOORS | NG | NOSE LANDING GEAR |
| E. | ELECTRICAL - GROUND POWER | P. | PNEUMATIC POWER |
| F. | PRESSURE REFUELING POINTS (4) | X. | PASSENGER DOOR |
| G. | GRAVITY REFUELING POINTS (6) | | |
| H ₂ O | POTABLE WATER (2) | | |
- TURNING RADIUS POINTS, 67°, 55°, 50°, 45°, 40°, 35°, 30°

9.0 SCALE DRAWINGS
 MODEL DC-8-61, -61F, -63, -63F, -71, -71F, -73, -73F

SCALE: 1 IN. = 100 FT

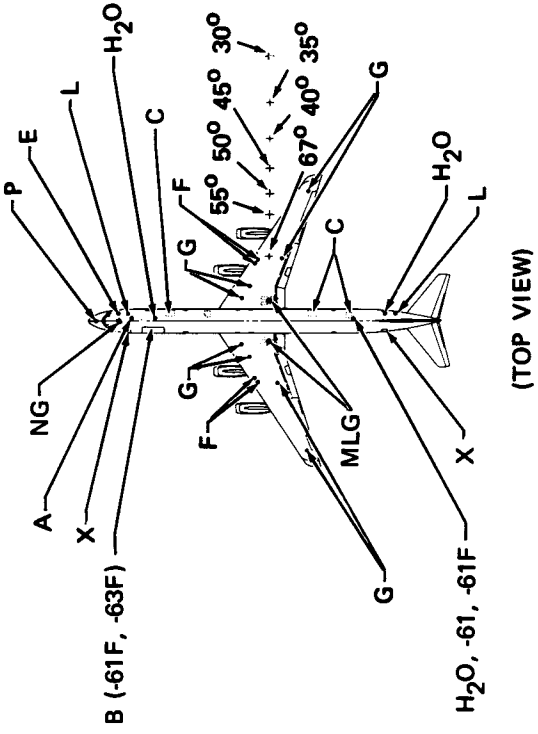

LEGEND

- | | | | |
|-----------------------|-------------------------------|------------|--|
| A. | PRECONDITIONED AIR | L. | LAVATORY |
| B. | MAIN CARGO DOOR | MLG | MAIN LANDING GEAR |
| C. | FWD, AFT CARGO DOORS | NG | NOSE LANDING GEAR |
| E. | ELECTRICAL - GROUND POWER | P. | PNEUMATIC POWER |
| F. | PRESSURE REFUELING POINTS (4) | X. | PASSENGER DOOR |
| G. | GRAVITY REFUELING POINTS (6) | | |
| H₂O | POTABLE WATER (2) | | |
| | | | TURNING RADIUS POINTS, 67°, 55°, 50°, 45°, 40°, 35°, 30° |

9.0 SCALE DRAWINGS
 MODEL DC-8-61, -61F, -63, -63F, -71, -71F, -73, -73F

SCALE: 1 IN. = 32 FT

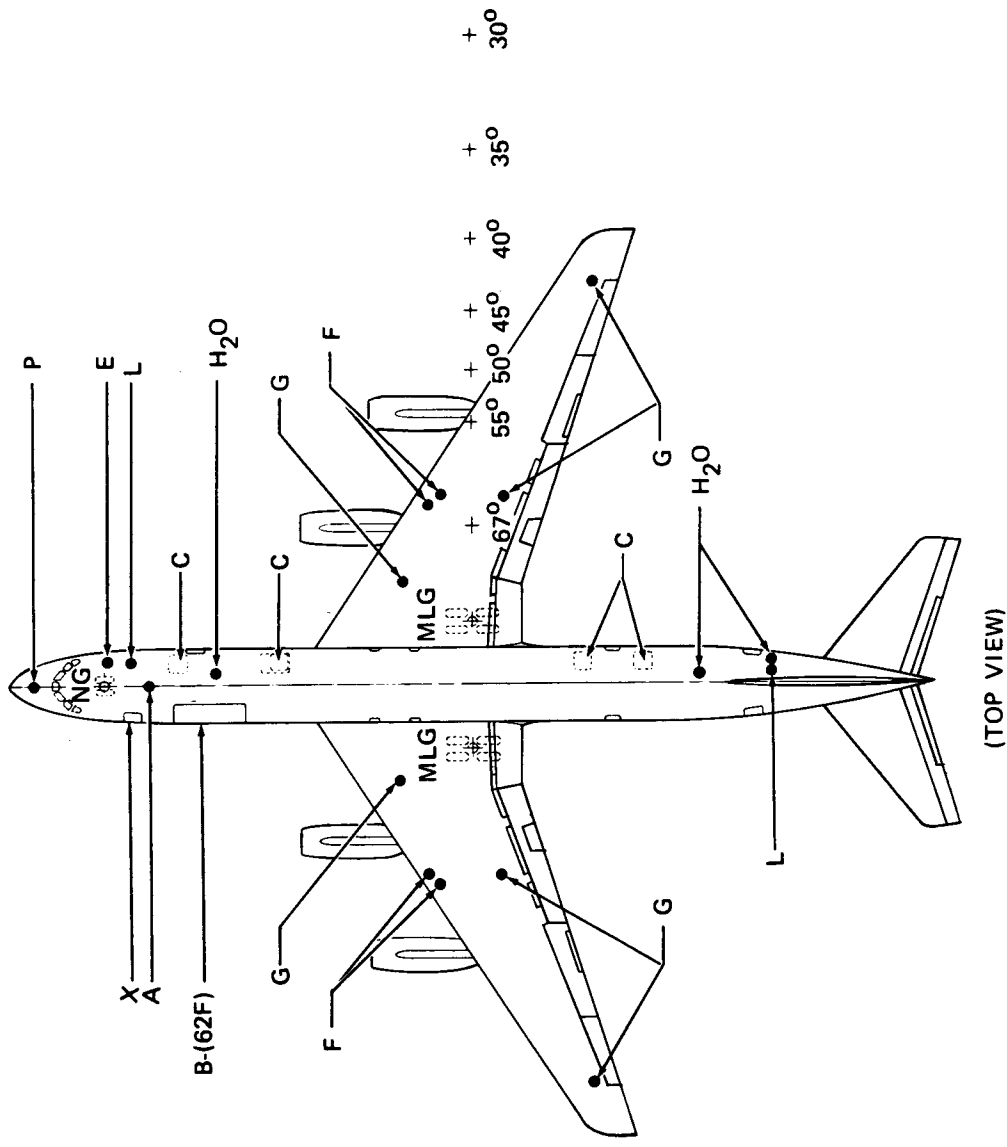

LEGEND

- A. PRECONDITIONED AIR
- B. MAIN CARGO DOOR
- C. FWD, AFT CARGO DOORS
- E. ELECTRICAL - GROUND POWER
- F. PRESSURE REFUELING POINTS (4)
- G. GRAVITY REFUELING POINTS (6)
- H₂O POTABLE WATER (2)

- L. LAVATORY
 - MLG MAIN LANDING GEAR
 - NG NOSE LANDING GEAR
 - P. PNEUMATIC POWER
 - X. PASSENGER DOOR
- TURNING RADIUS POINTS, 67°, 55°, 50°, 45°, 40°, 35°, 30°

9.0 SCALE DRAWINGS
MODEL DC-8-62, -62F, -72, -72F

SCALE: 1 IN. = 50 FT

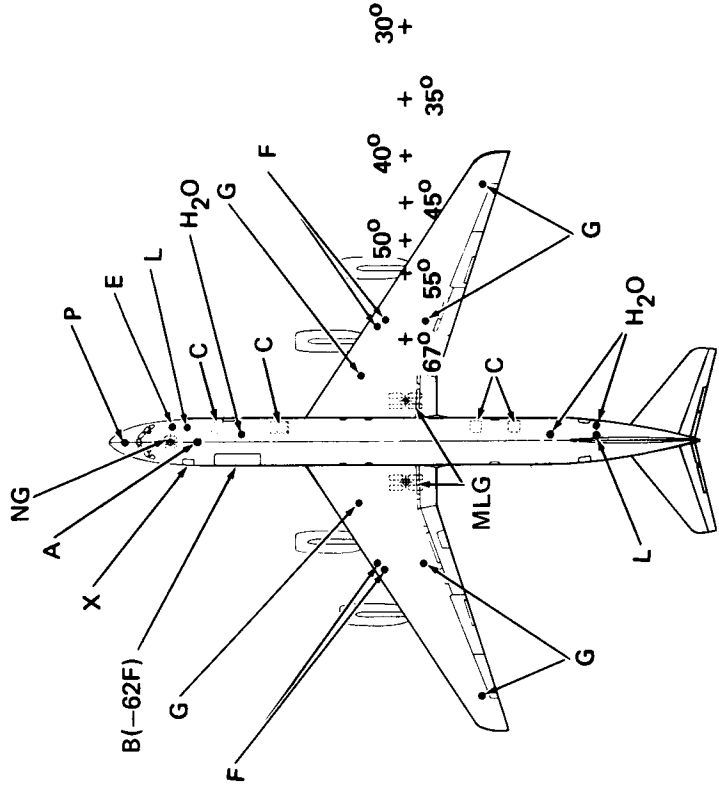

(TOP VIEW)

LEGEND

- | | | | |
|------------------|-------------------------------|-----|-------------------|
| A. | PRECONDITIONED AIR | L. | LAVATORY |
| B. | MAIN CARGO DOOR | MLG | MAIN LANDING GEAR |
| C. | FWD, AFT CARGO DOORS | NG | NOSE LANDING GEAR |
| E. | ELECTRICAL - GROUND POWER | P. | PNEUMATIC POWER |
| F. | PRESSURE REFUELING POINTS (4) | X. | PASSENGER DOOR |
| G. | GRAVITY REFUELING POINTS (6) | | |
| H ₂ O | POTABLE WATER (2) | | |
- TURNING RADIUS POINTS, 67°, 55°, 50°, 45°, 40°, 35°, 30°

9.0 SCALE DRAWINGS
MODEL DC-8-62, -62F, -72, -72F

SCALE: 1 IN. = 100 FT

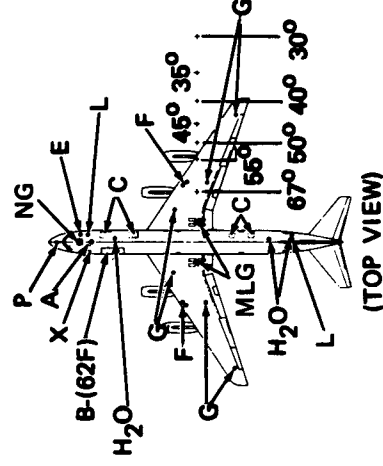

LEGEND

- | | | | |
|------------------|-------------------------------|-----|-------------------|
| A. | PRECONDITIONED AIR | L. | LAVATORY |
| B. | MAIN CARGO DOOR | MLG | MAIN LANDING GEAR |
| C. | FWD, AFT CARGO DOORS | NG | NOSE LANDING GEAR |
| E. | ELECTRICAL - GROUND POWER | P. | PNEUMATIC POWER |
| F. | PRESSURE REFUELING POINTS (4) | X. | PASSENGER DOOR |
| G. | GRAVITY REFUELING POINTS (6) | | |
| H ₂ O | POTABLE WATER (2) | | |
- TURNING RADIUS POINTS, 67°, 55°, 50°, 45°, 40°, 35°, 30°

9.0 SCALE DRAWINGS
MODEL DC-8-62, -62F, -72, -72F