

DC-9

**AIRPLANE
CHARACTERISTICS
FOR
AIRPORT PLANNING
JUNE 1984**

DOUGLAS AIRCRAFT COMPANY

Not Subject to US Export Administration Regulations (EAR), (15 C.F.R. Parts 730-774)
or US International Traffic in Arms Regulations (ITAR), (22 C.F.R. Parts 120-130).

Copyright © 2023 Boeing. All Rights Reserved.

CONTENTS

	Page
1.0 SCOPE	1
1.1 Purpose	1
1.2 Introduction	2
2.0 AIRPLANE DESCRIPTION	3
2.1 General Airplane Characteristics	4
2.2 General Airplane Dimensions	5
2.3 Ground Clearances	10
2.4 Interior Arrangements	15
2.4.1 Passengers	15
2.4.2 Cargo	19
2.4.3 Pallet Envelopes	21
2.5 Passenger Cabin Cross Section	23
2.5.1 Coach	23
2.5.2 First Class	24
2.6 Lower Compartment (No Containers)	25
2.7 Door Clearances	26
2.7.1 Lower Forward Cargo Door Clearances	26
2.7.2 Lower Aft Cargo Door Clearances	27
2.7.3 Upper Cargo Door Clearances	28
2.7.4 Passenger Entrance and Service Door Clearances	29
2.7.5 Main Entrance Stairway Clearances	30
2.7.6 Forward Passenger Door Opening Clearances	31
2.7.8 Ventral Stair Clearances	33
3.0 AIRPLANE PERFORMANCE	35
3.1 General Information	35
3.2 Payload Range	36
3.3 FAR Takeoff Runway Length Requirements	47
3.4 FAR Landing Runway Length Requirements	51

CONTENTS
(Continued)

	Page
4.0 GROUND MANEUVERING	59
4.1 General Information	59
4.2 Turning Radii, No Slip Angle	60
4.3 Minimum Turning Radii	65
4.4 Runway and Taxiway Turn Paths	66
4.4.1 More Than 90 Deg Turn – Runway To Taxiway	66
4.4.2 90 Deg Turn – Runway to Taxiway	71
4.4.3 90 Deg Turn – Taxiway to Taxiway – Nose Gear Tracking Beyond Taxiway Centerline	76
4.4.4 90 Deg Turn – Taxiway to Taxiway – Cockpit Tracks Centerline to Centerline	81
4.5 Runway Holding Bay (Apron)	86
5.0 TERMINAL SERVICING	91
5.1 Airplane Servicing Arrangement (Typical)	91
5.2 Terminal Operations, Turnaround Station	96
5.3 Terminal Operations, En Route Station	100
5.4 Ground Service Connections	104
5.4.1 Hydraulic System	109
5.4.2 Electrical System	109
5.4.3 Oxygen System	109
5.4.4 Fuel System	109
5.4.5 Pneumatic System	110
5.4.6 Potable Water System	110
5.4.7 Lavatory System	110
5.4.8 Engine Service System	111
5.5 Engine Starting Pneumatic Requirements	121
5.6 Ground Pneumatic Power Requirements	122
5.7 Preconditioned Airflow Requirements	126
5.8 Ground Towing Requirements	130

CONTENTS
(Continued)

	Page
6.0 OPERATING CONDITIONS	133
6.1 Jet Engine Exhaust Velocities and Temperatures	133
6.1.1 Jet Engine Exhaust Velocity Contours, Breakaway Power	133
6.1.2 Jet Engine Exhaust Temperature Contours, Breakaway Power	134
6.1.3 Jet Engine Exhaust Velocity Contours, Takeoff Power	135
6.1.4 Jet Engine Exhaust Temperature Contours, Takeoff Power	136
6.1.5 Jet Engine Exhaust Velocity Contours, Idle Power	137
6.1.6 Jet Engine Exhaust Temperature Contours, Idle Power	138
6.2 Airport and Community Noise	139
7.0 PAVEMENT DATA	141
7.1 General Information	141
7.2 Footprint	143
7.3 Maximum Pavement loads	145
7.4 Landing Gear Loading on Pavement	146
7.5 Flexible Pavement Requirements, U.S. Corps of Engineers Design Method	151
7.6 Flexible Pavement Requirements, LCN Conversion	153
7.7 Rigid Pavement Requirements, Portland Cement Association Design Method	159
7.8 Rigid Pavement Requirements, LCN Conversion	165
7.8.1 Radius of Relative Stiffness	171
7.9 ACN-PCN Reporting System: Flexible and Rigid Pavements	174
8.0 POSSIBLE DC-9 DERIVATIVE AIRPLANES	181
9.0 SCALE DRAWINGS	183

REVISION DATA
DC-9 AIRPLANE CHARACTERISTICS - AIRPORT PLANNING

LIST OF CURRENT PAGES. (New is original printing)

NO.	REV	DATE	NO.	REV	DATE	NO.	REV	DATE	NO.	REV	DATE
i	F	5/84	39	F	5/84	84	F	5/84	129	F	5/84
ii	F	5/84	40	F	5/84	85	F	5/84	130	F	5/84
iii	F	5/84	41	F	5/84	86	F	5/84	131	F	5/84
iv	F	5/84	42	F	5/84	87	F	5/84	132	Blank	
v	F	5/84	43	F	5/84	88	F	5/84	133	F	5/84
vi	F	5/84	44	F	5/84	89	F	5/84	134	F	5/84
vii	F	5/84	45	F	5/84	90	F	5/84	135	F	5/84
1	F	5/84	46	F	5/84	91	F	5/84	136	F	5/84
2	F	5/84	47	F	5/84	92	F	5/84	137	F	5/84
3	F	5/84	48	F	5/84	93	F	5/84	138	F	5/84
4	F	5/84	49	F	5/84	94	F	5/84	139	F	5/84
5	F	5/84	50	F	5/84	95	F	5/84	140	F	5/84
6	F	5/84	51	F	5/84	96	F	5/84	141	F	5/84
7	F	5/84	52	F	5/84	97	F	5/84	142	F	5/84
8	F	5/84	53	F	5/84	98	F	5/84	143	F	5/84
9	F	5/84	54	F	5/84	99	F	5/84	144	F	5/84
10	F	5/84	55	F	5/84	100	F	5/84	145	F	5/84
11	F	5/84	56	F	5/84	101	F	5/84	146	F	5/84
12	F	5/84	57	F	5/84	102	F	5/84	147	F	5/84
13	F	5/84	58	F	5/84	103	F	5/84	148	F	5/84
14	F	5/84	59	F	5/84	104	F	5/84	149	F	5/84
15	F	5/84	60	F	5/84	105	F	5/84	150	F	5/84
16	F	5/84	61	F	5/84	106	F	5/84	151	F	5/84
17	F	5/84	62	F	5/84	107	F	5/84	152	New	
18	F	5/84	63	F	5/84	108	F	5/84	153	F	5/84
19	F	5/84	64	F	5/84	109	F	5/84	154	F	5/84
20	F	5/84	65	F	5/84	110	F	5/84	155	F	5/84
21	F	5/84	66	F	5/84	111	F	5/84	156	F	5/84
22	F	5/84	67	F	5/84	112	F	5/84	157	F	5/84
23	F	5/84	68	F	5/84	113	F	5/84	158	F	5/84
24	F	5/84	69	F	5/84	114	F	5/84	159	F	5/84
25	F	5/84	70	F	5/84	115	F	5/84	160	F	5/84
26	F	5/84	71	F	5/84	116	F	5/84	161	F	5/84
27	F	5/84	72	F	5/84	117	F	5/84	162	F	5/84
28	F	5/84	73	F	5/84	118	F	5/84	163	F	5/84
29	F	5/84	74	F	5/84	119	F	5/84	164	F	5/84
30	F	5/84	75	F	5/84	120	F	5/84	165	F	5/84
31	F	5/84	76	F	5/84	121	F	5/84	166	F	5/84
32	F	5/84	77	F	5/84	122	F	5/84	167	F	5/84
33	F	5/84	78	F	5/84	123	F	5/84	168	F	5/84
34	Blank		79	F	5/84	124	F	5/84	169	F	5/84
35	F	5/84	80	F	5/84	125	F	5/84	170	F	5/84
36	F	5/84	81	F	5/84	126	F	5/84	171	F	5/84
37	F	5/84	82	F	5/84	127	F	5/84	172	F	5/84
38	F	5/84	83	F	5/84	128	F	5/84	173	F	5/84

REVISION DATA (Cont)

NO.	REV	DATE
174	New	5/84
175	New	5/84
176	New	5/84
177	New	5/84
178	New	5/84
179	New	5/84
180	New	5/84
181	F	5/84
182	Blank	5/84
183	F	5/84
184	F	5/84
185	F	5/84
186	F	5/84
187	F	5/84
188	F	5/84
189	F	5/84
190	F	5/84
191	F	5/84
192	F	5/84
193	F	5/84
194	F	5/84
195	F	5/84
196	F	5/84
197	F	5/84
198	F	5/84
199	F	5/84
200	F	5/84
201	F	5/84
202	F	5/84
203	F	5/84
204	F	5/84
205	F	5/84
206	F	5/84
207	F	5/84
208	Blank	

1.0 SCOPE

1.1 Purpose

1.2 Introduction

1.0 SCOPE

1.1 Purpose

This document provides, in a standardized format, airplane characteristics data for general airport planning information. There are numerous versions of the model DC-9.* The DC-9 data in this document are for the most critical model in each series considering airport operations. Since operational practices vary among airlines, specific data should be coordinated with the using airlines prior to facility design. The Douglas Aircraft Company should be contacted for any additional information required.

Content of the document reflects the results of a coordinated effort by representatives from the following organizations:

Aerospace Industries Association of America
Airport Operators' Council International
Air Transport Association of America
International Air Transport Association

*The following DC-9 models have been certified by the FAA to date: DC-9-11, DC-9-12, DC-9-13, DC-9-14, DC-9-15, DC-9-15F, DC-9-21, DC-9-31, DC-9-32, DC-9-32F, DC-9-33F, DC-9-41, and DC-9-51.

1.2 Introduction

This document conforms to NAS 3601. It provides Model DC-9 characteristics for airport operators, airlines, and engineering consultant organizations. Since airplane changes and available options may alter the information, the data presented herein must be regarded as subject to change. Similarly, for airplanes not yet certified, changes can be expected to occur.

For further information, contact:

Boeing Commercial Airplane Group
P.O. Box 3707
Seattle, Washington 98124-2207
USA

Attention: Manager, Airport Technology
Mail Code 67-KR

or

Phone: 425-237-0126
FAX: 425-237-0860
<http://www.boeing.com/assocproducts/aircompat/index.htm>

Note, this document is available electronically at the following website:
<http://www.boeing.com/assocproducts/aircompat/index.htm>

2.0 AIRPLANE DESCRIPTION

- 2.1 General Airplane Characteristics**
- 2.2 General Airplane Dimensions**
- 2.3 Ground Clearances**
- 2.4 Interior Arrangements**
- 2.5 Passenger Cabin Cross Section**
- 2.6 Lower Compartments (No Containers)**
- 2.7 Door Clearances**

2.0 AIRPLANE DESCRIPTION

2.1 General Airplane Characteristics – Douglas DC-9 (Definitions Refer to Items in Figure 2.1)

Maximum Ramp Weight. Maximum weight authorized for ground maneuver by applicable government regulations, including taxi and runup fuel. Also designated in some manuals as maximum design taxi weight.

Maximum Landing Weight. Maximum weight authorized at touchdown by the applicable government regulations.

Maximum Takeoff Weight. Maximum weight authorized at takeoff brake release by the applicable government regulations and excludes taxi and runup fuel.

Operating Weight Empty. Weight of structure, power plant, furnishings, systems, unusable fuel and other unusable propulsion agents, and other items of equipment that are considered an integral part of a particular aircraft configuration. Also included are certain standard items, personnel, equipment, and supplies necessary for full operation, excluding fuel and payload. Described as “Operating Empty Weight” in some manuals.

Zero Fuel Weight. Maximum airplane weight less usable fuel, engine injection fluid, and other consumable propulsion agents. It may include usable fuel in specified tanks when carried in lieu of payload. The addition of usable and consumable items to the Zero Fuel Weight must be in accordance with the applicable government regulations so that airplane structure and airworthiness requirements are not exceeded.

Maximum Structural Payload. Consists of the maximum design payload weight of passengers, passenger baggage and/or cargo.

Maximum Seating Capacity. The maximum number of passengers specifically certified or anticipated for certification.

Maximum Cargo Volume. The maximum space available for cargo.

Usable Fuel Capacity. The volume of fuel carried for a particular operation, less drainable unusable fuel and trapped fuel remaining after a fuel runout test has been accomplished.

		MODEL DC-9-15	MODEL DC-9-15F	MODEL DC-9-21	MODEL DC-9-32	MODEL DC-9-33F	MODEL DC-9-41	MODEL DC-9-51
MAXIMUM RAMP WEIGHT	POUNDS	91,500	91,500	101,000	109,000	109,000	115,000	122,000
	KILOGRAMS	41,504	41,504	45,813	49,442	49,442	52,163	55,338
MAXIMUM LANDING WEIGHT	POUNDS	81,700	81,700	95,300	99,000	99,000	102,000	110,000
	KILOGRAMS	37,059	37,059	43,227	44,906	44,906	46,266	49,895
MAXIMUM TAKEOFF WEIGHT	POUNDS	90,700	90,700	98,000	108,000	108,000	114,000	121,000
	KILOGRAMS	41,141	41,141	45,359	48,988	48,988	51,710	54,885
OPERATING WEIGHT EMPTY	POUNDS	49,162	53,200	52,644	56,855	56,430	61,335	64,675
	KILOGRAMS	22,300	24,131	23,879	25,789	25,596	27,821	29,336
ZERO FUEL WEIGHT	POUNDS	74,000	74,000	84,000	87,000	90,000	93,000	98,500
	KILOGRAMS	33,566	33,566	38,102	39,463	40,823	42,184	44,679
MAXIMUM STRUCTURAL PAYLOAD	POUNDS	24,838	20,800	25,356	30,145	13,530	31,665	33,825
	KILOGRAMS	11,266	9,435	11,501	13,674	6,137	14,363	15,343
MAXIMUM SEATING CAPACITY SEE PAGES 17 THROUGH 21	PASSENGERS	90	—	90	115	—	125	135
MAXIMUM CARGO VOLUME SEE PAGES 22, 23, AND 28	CUBIC FEET	600	2,762	600	895	4,195	1,019	1,174
	CUBIC METERS	17.0	78.2	17.0	25.3	119.0	28.9	33.2
USABLE FUEL CAPACITY	U.S. GALLONS	3,693	3,699	3,679	3,679	3,679	3,679	3,679
	LITERS	13,979	13,926	13,926	13,926	13,926	13,926	13,926
	POUNDS	24,743	24,649	24,649	24,649	24,649	24,649	24,649
	KILOGRAMS	11,223	11,181	11,181	11,181	11,181	11,181	11,181

2.1 GENERAL AIRPLANE CHARACTERISTICS MODEL DC-9

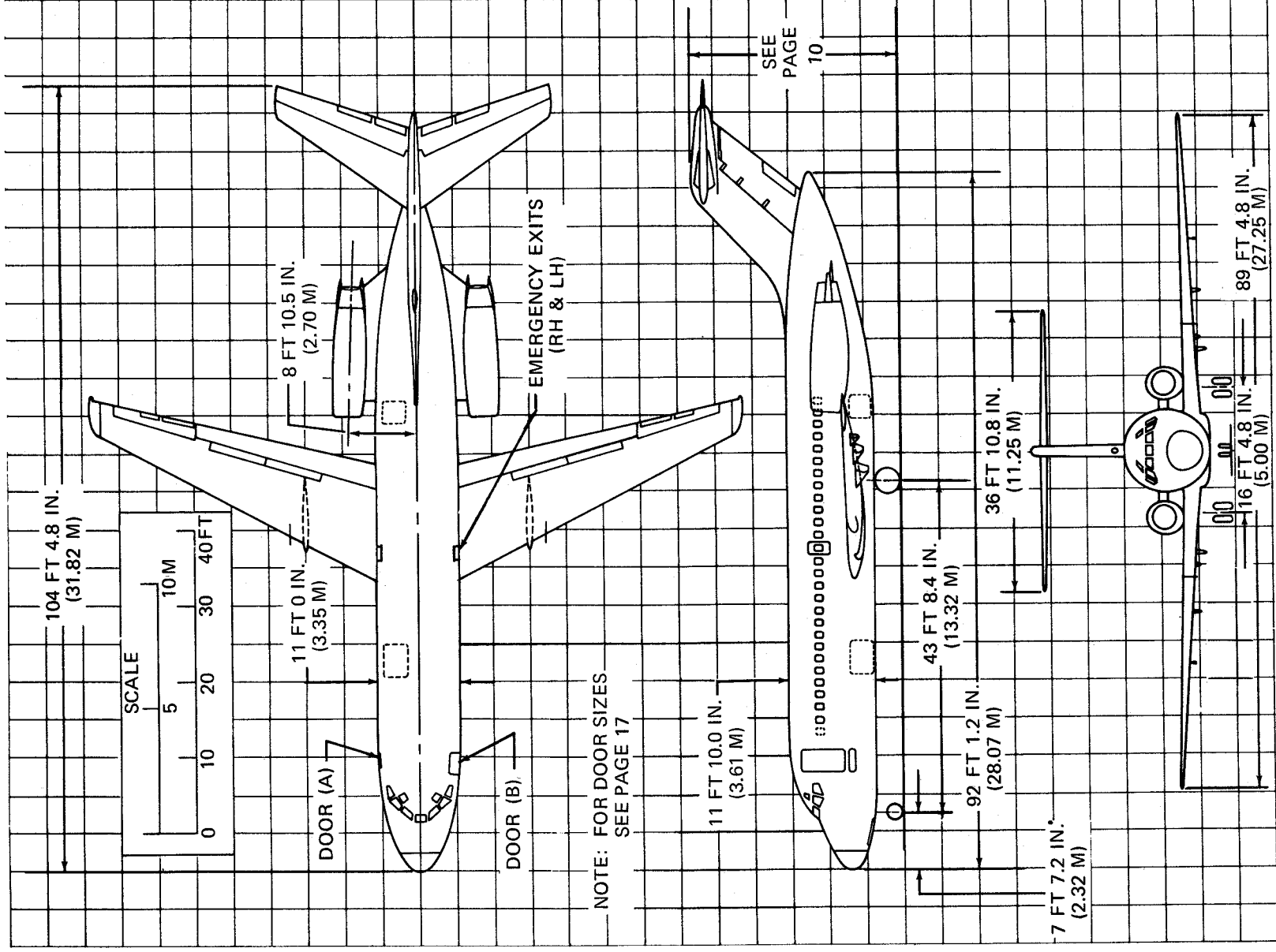

2.2 GENERAL AIRPLANE DIMENSIONS

MODEL DC-9-15

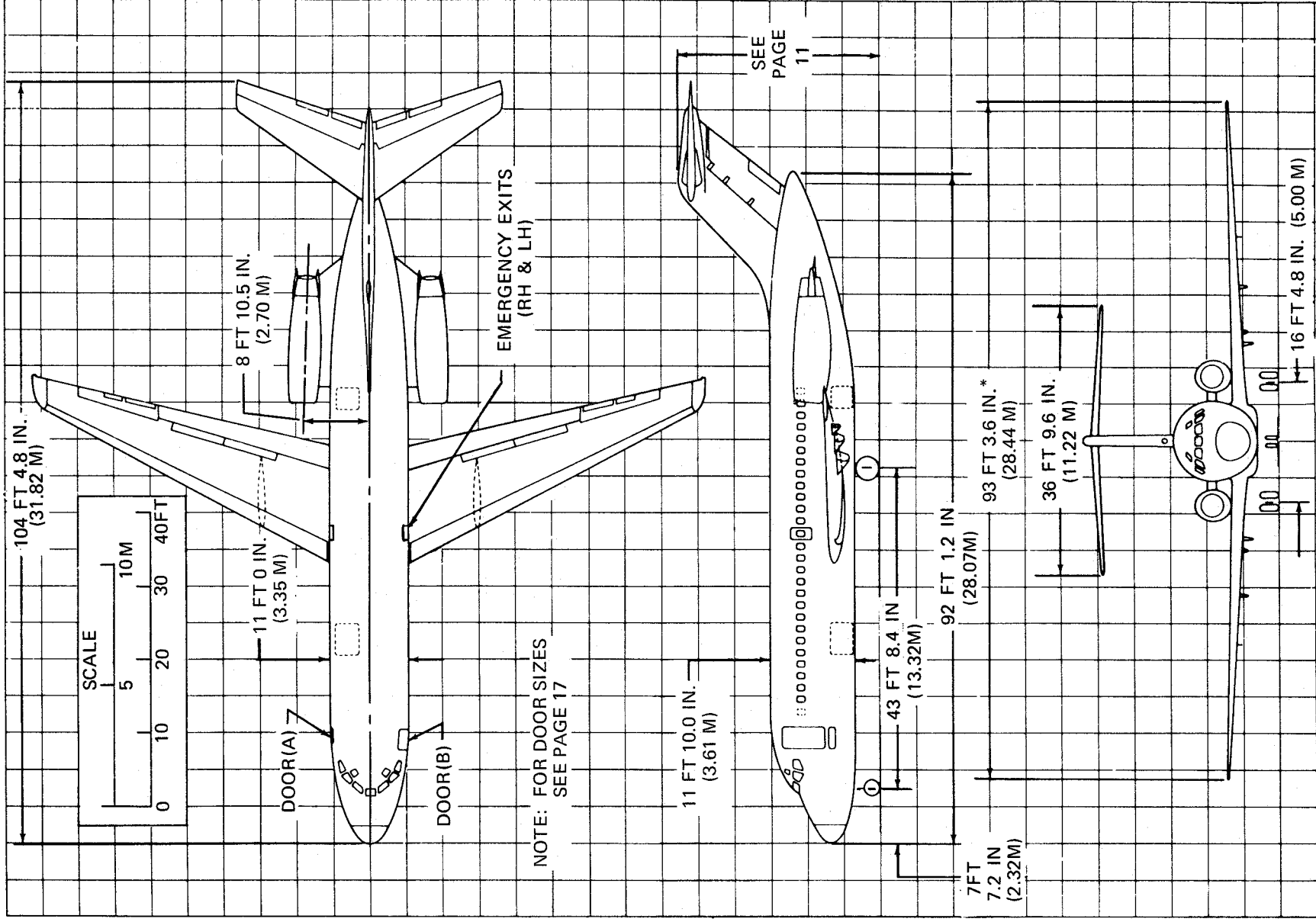

2.2 GENERAL AIRPLANE DIMENSIONS

MODEL DC-9-21

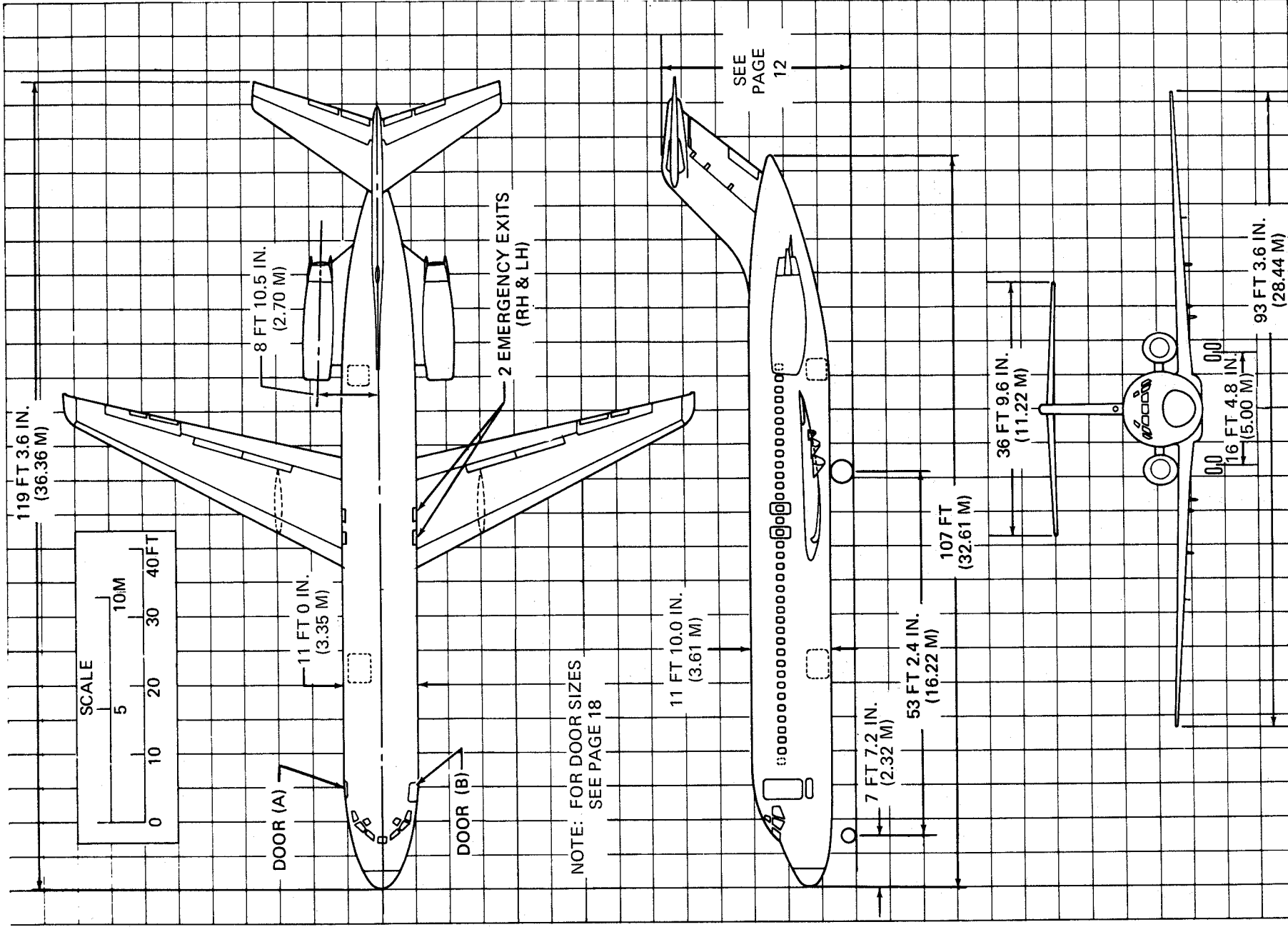

REV F5/84

2.2 GENERAL AIRPLANE DIMENSIONS

MODEL DC-9-32
7

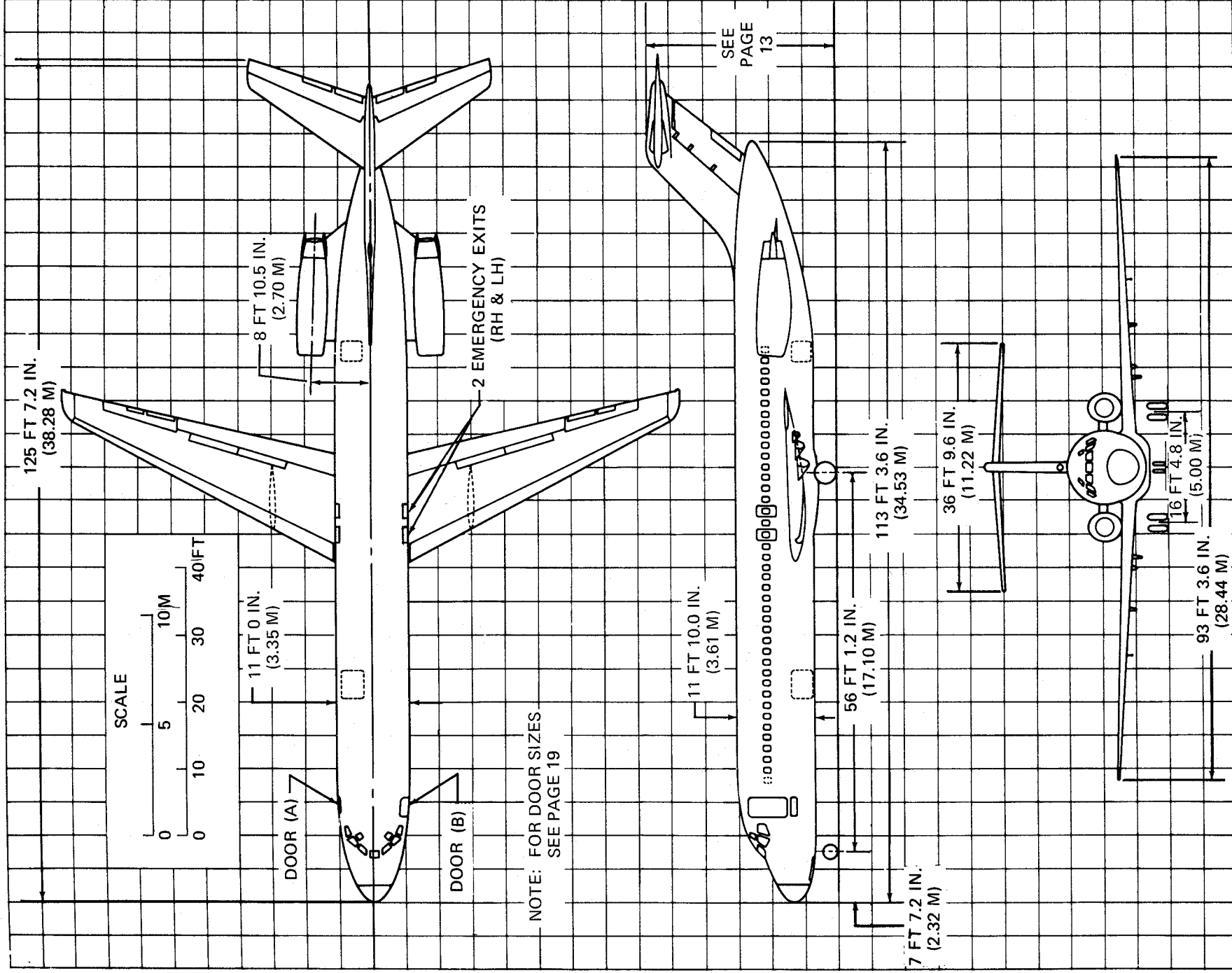

2.2 GENERAL AIRPLANE DIMENSIONS MODEL DC-9-41

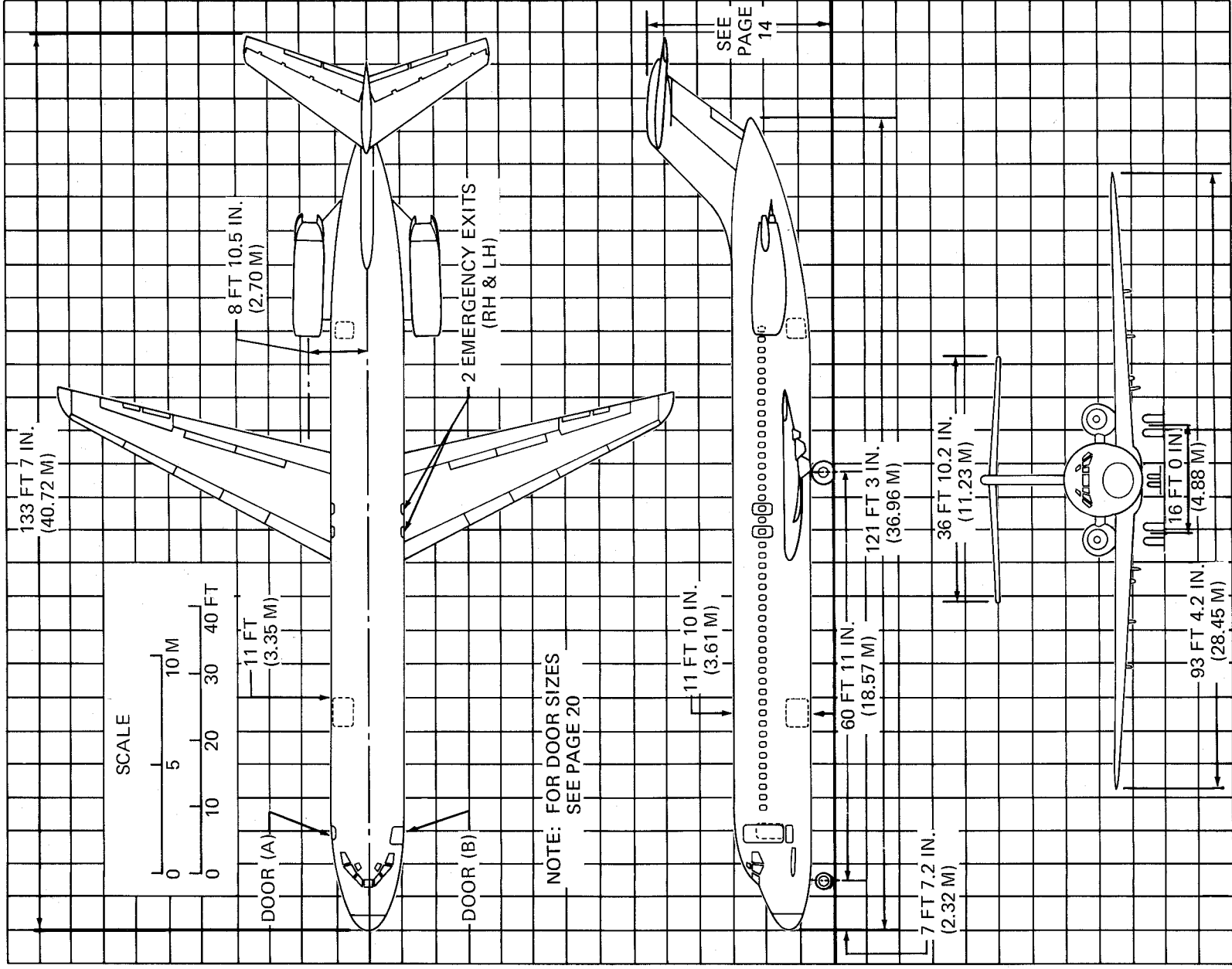

2.2 GENERAL AIRPLANE DIMENSIONS MODEL DC-9-51

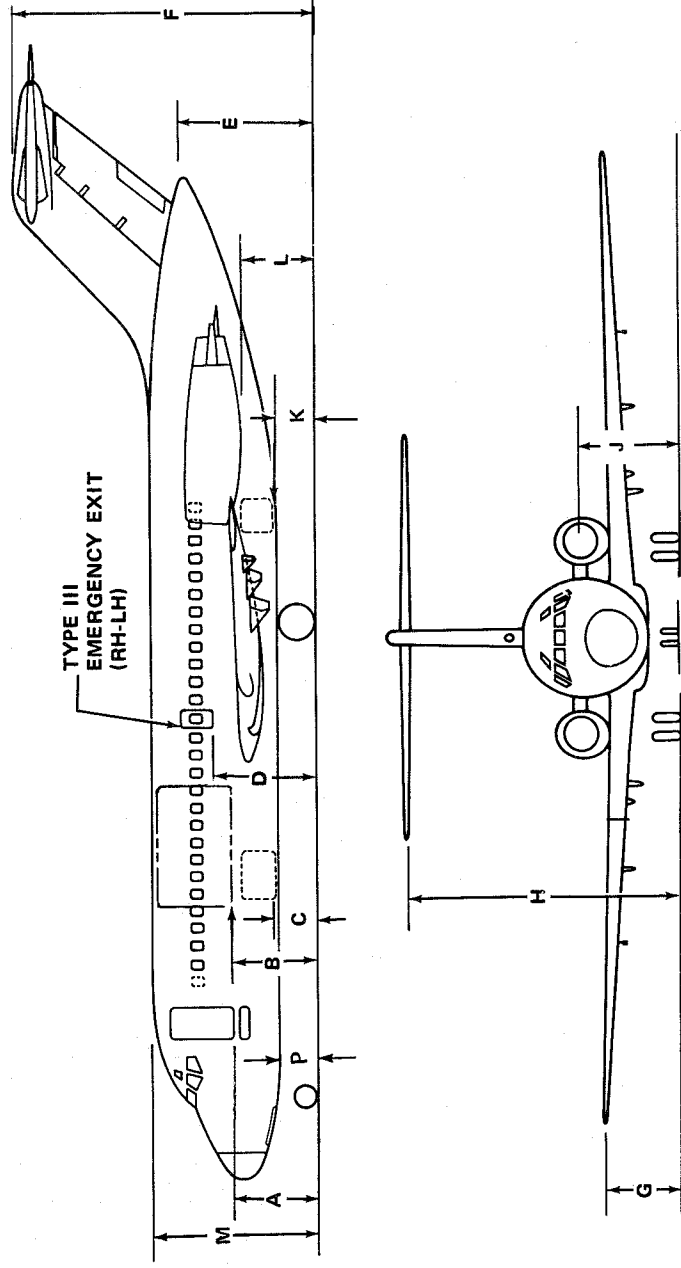

VERTICAL CLEARANCES				
	MAXIMUM		MINIMUM	
	FT - IN.	METERS	FT - IN.	METERS
A	7-9	2.4	7-2	2.2
B	7-4	2.2	7-0	2.1
C	3-8	1.1	3-3	1.0
D	9-4	2.8	9-5	2.9
E	11-6	3.5	11-8	3.6
F	27-7	8.4	27-5	8.4
G	7-6	2.3	7-2	2.2
H	24-8	7.5	24-6	7.5
J	9-10	3.0	9-7	2.9
K	3-8	1.1	3-3	1.0
L	6-8	2.0	6-5	2.0
M	15-5	4.7	14-9	4.5
P	3-4	1.0	3-0	0.9

IT IS RECOMMENDED THAT APPROXIMATELY ±3 INCHES (±8 cm) BE ALLOWED FOR VERTICAL EXCURSIONS DUE TO LOADING, VARYING STRUT AND TIRE INFLATIONS, PAVEMENT UNEVENNESS, ETC.

2.3 GROUND CLEARANCES MODEL DC-9-15

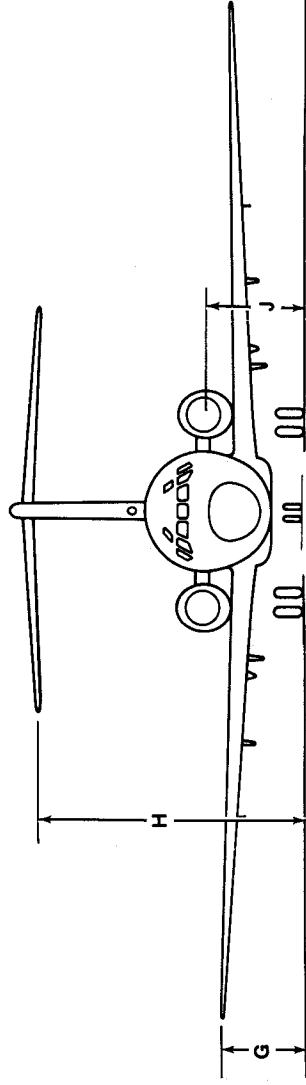
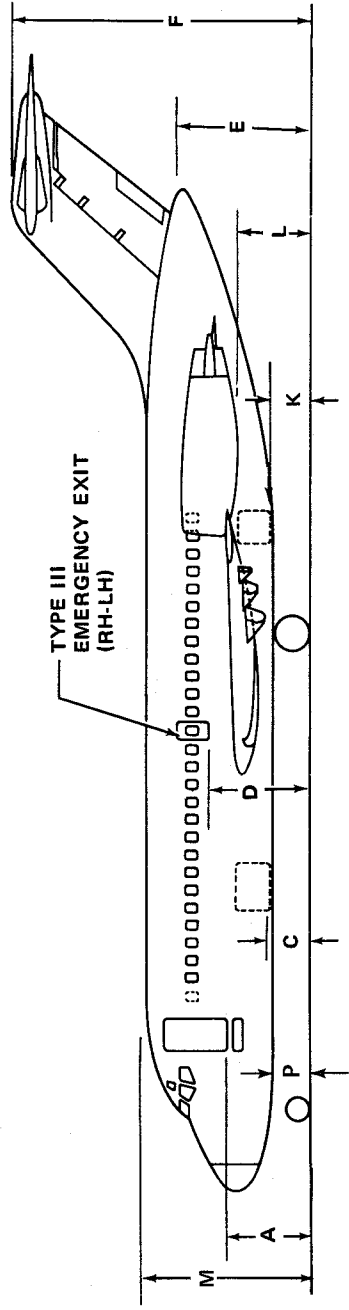

VERTICAL CLEARANCES				
	MAXIMUM		MINIMUM	
	FT - IN.	METERS	FT - IN.	METERS
A	7 - 10	2.4	7 - 2	2.2
B	-	-	-	-
C	3 - 7	1.1	3 - 3	1.0
D	9 - 3	2.8	8 - 11	2.7
E	11 - 4	3.5	11 - 8	3.6
F	27 - 5	8.4	27 - 5	8.4
G	7 - 8	2.3	7 - 3	2.2
H	24 - 5	7.4	24 - 6	7.5
J	9 - 10	3.0	9 - 6	2.9
K	3 - 9	1.1	9 - 3	1.0
L	6 - 8	2.0	6 - 5	2.0
M	15 - 7	4.7	14 - 9	4.5
P	3 - 4	1.0	3 - 0	0.9

IT IS RECOMMENDED THAT APPROXIMATELY ±3 INCHES (±8 cm) BE ALLOWED FOR VERTICAL EXCURSIONS DUE TO LOADING, VARYING STRUT AND TIRE INFLATIONS, PAVEMENT UNEVENNESS, ETC.

2.3 GROUND CLEARANCES MODEL DC-9-21

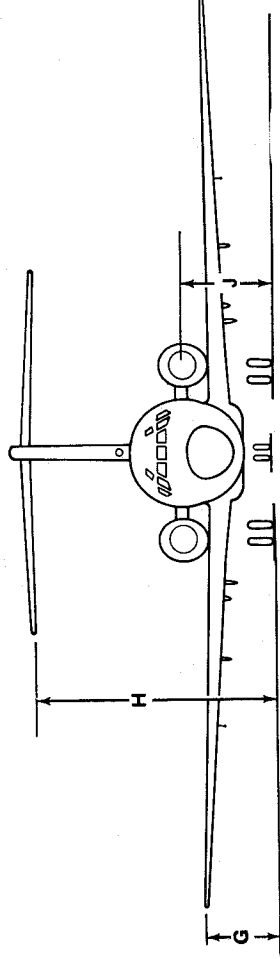
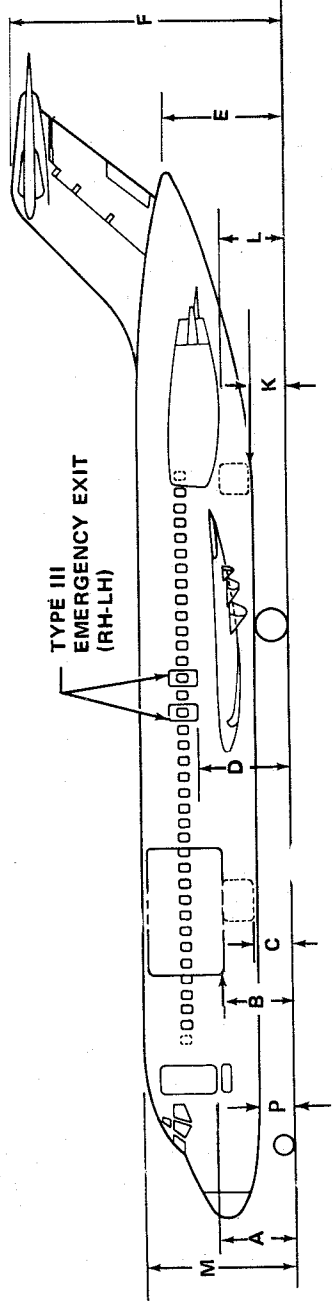

VERTICAL CLEARANCES				
	MAXIMUM		MINIMUM	
	FT - IN.	METERS	FT - IN.	METERS
A	7-8	2.3	7-2	2.2
B	7-5	2.3	7-0	2.1
C	3-4	1.0	3-1	0.9
D	8-10	2.7	8-7	2.6
E	11-7	3.5	11-7	3.5
F	27-9	8.5	27-6	8.4
G	7-8	2.3	7-3	2.2
H	24-8	7.5	24-6	7.5
J	9-11	3.0	9-8	2.9
K	3-8	1.1	3-5	1.0
L	6-9	2.1	6-5	2.0
M	15-4	4.7	14-9	4.5
P	3-4	1.0	3-0	0.9

IT IS RECOMMENDED THAT APPROXIMATELY ± 3 INCHES (± 8 cm) BE ALLOWED FOR VERTICAL EXCURSIONS DUE TO LOADING, VARYING STRUT AND TIRE INFLATIONS, PAVEMENT UNEVENNESS, ETC.

2.3 GROUND CLEARANCES MODEL DC-9-32

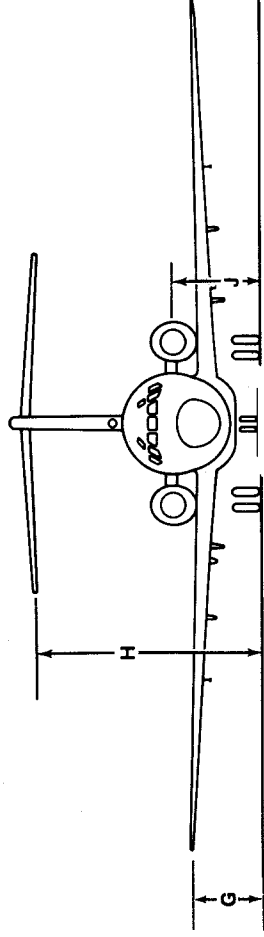
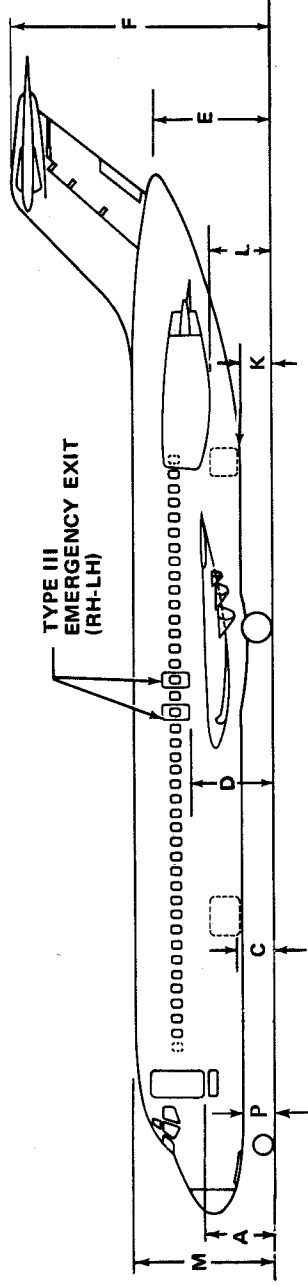

VERTICAL CLEARANCES				
	MAXIMUM		MINIMUM	
	FT - IN.	METERS	FT - IN.	METERS
A	7 - 7	2.3	7 - 2	2.2
B	-	-	-	-
C	3 - 7	1.1	3 - 3	1.0
D	9 - 6	2.9	9 - 1	2.8
E	12 - 2	3.7	12 - 2	3.7
F	28 - 5	8.7	28 - 0	8.5
G	7 - 7	2.3	7 - 2	2.2
H	25 - 3	7.7	25 - 0	7.6
J	10 - 5	3.2	10 - 1	3.1
K	4 - 5	1.3	4 - 1	1.2
L	7 - 4	2.2	6 - 11	2.1
M	15 - 6	4.7	14 - 9	4.5
P	3 - 5	1.0	3 - 0	0.9

IT IS RECOMMENDED THAT APPROXIMATELY ± 3 INCHES (± 8 cm) BE ALLOWED FOR VERTICAL EXCURSIONS DUE TO LOADING, VARYING STRUT AND TIRE INFLATIONS, PAVEMENT UNEVENNESS, ETC.

2.3 GROUND CLEARANCES MODEL DC-9-41

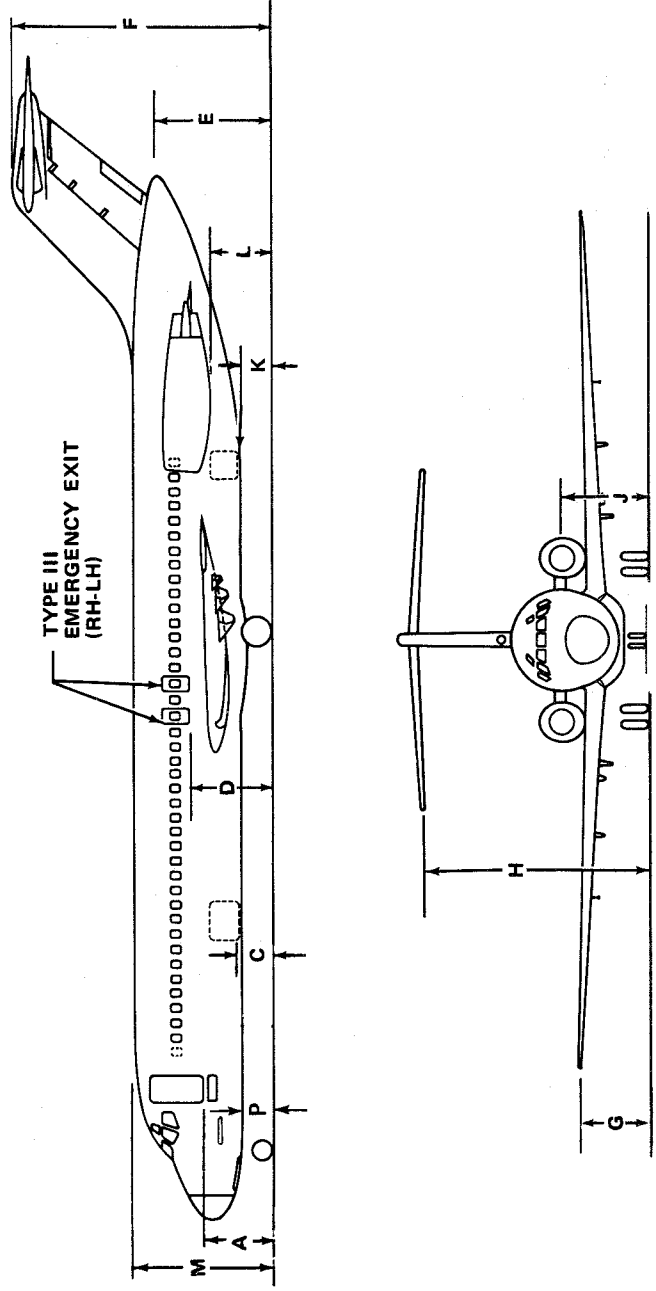

VERTICAL CLEARANCES				
	MAXIMUM		MINIMUM	
	FT - IN.	METERS	FT - IN.	METERS
A	7-8	2.3	7-3	2.2
B	-	-	-	-
C	3-8	1.1	3-4	1.0
D	9-4	2.8	9-0	2.7
E	12-5	3.8	12-4	3.8
F	28-9	8.8	28-3	8.6
G	7-5	2.3	7-1	2.2
H	25-7	7.8	25-3	7.7
J	10-5	3.2	10-1	3.1
K	4-5	1.3	4-1	1.2
L	7-3	2.2	6-10	2.1
M	15-4	4.7	14-8	4.5
P	3-5	1.0	3-0	0.9

IT IS RECOMMENDED THAT APPROXIMATELY +3 INCHES (+8 cm) BE ALLOWED FOR VERTICAL EXCURSIONS DUE TO LOADING, VARYING STRUT AND TIRE INFLATIONS, PAVEMENT UNEVENNESS, ETC.

2.3 GROUND CLEARANCES MODEL DC-9-51

90 PASSENGERS, 5-ABREAST SEATING

50 SEATS ON 32 IN. (81.3 CM) PITCH
40 SEATS ON 31 IN. (78.7 CM) PITCH

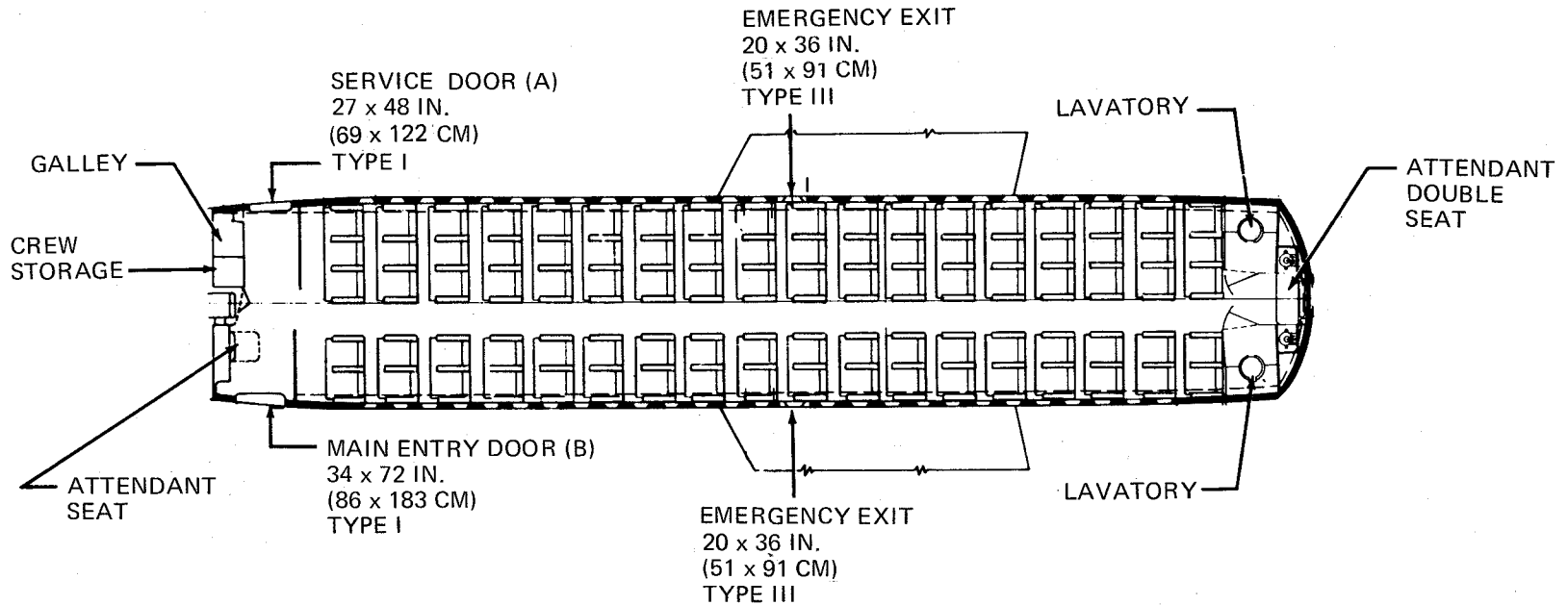

NOTE: MAXIMUM OF 90 PASSENGERS, 5-ABREAST SEATING AVAILABLE

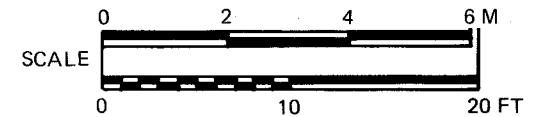

2.4 INTERIOR ARRANGEMENTS
2.4.1 PASSENGERS
MODEL DC-9-15 AND -21

115 PASSENGERS, 5-ABREAST SEATING

55 SEATS ON 33 IN. (83.8 CM) PITCH
10 SEATS ON 36 IN. (91.4 CM) PITCH
50 SEATS ON 31 IN. (78.7 CM) PITCH

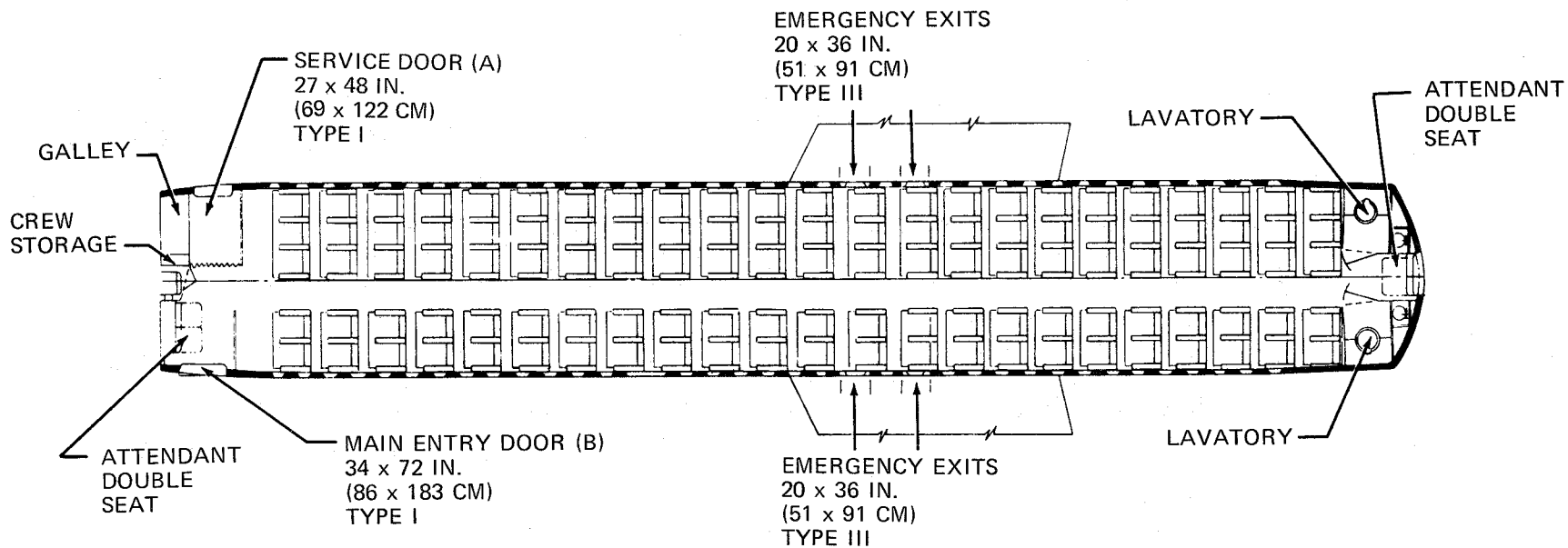

NOTE: MAXIMUM OF 127
PASSENGERS, 5-ABREAST
SEATING AVAILABLE

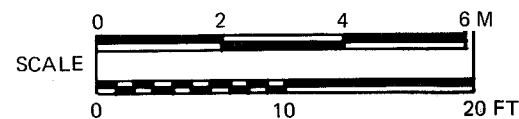

2.4 INTERIOR ARRANGEMENTS
2.4.1 PASSENGERS
MODEL DC-9-32

125 PASSENGERS, 5-ABREAST SEATING

65 SEATS ON 34 IN. (86.4 CM) PITCH
5 SEATS ON 33 IN. (83.8 CM) PITCH
30 SEATS ON 32 IN. (81.3 CM) PITCH
25 SEATS ON 31 IN. (78.7 CM) PITCH

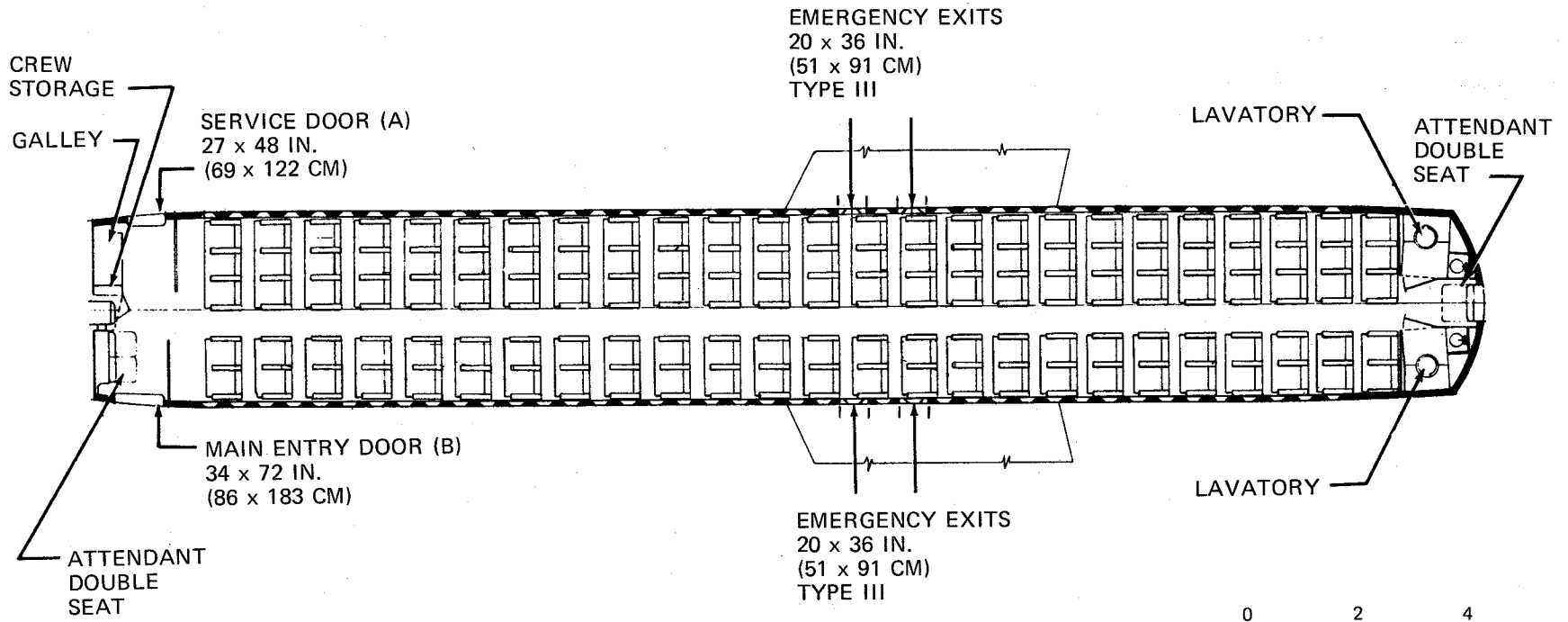

NOTE: MAXIMUM OF 128 PASSENGERS, 5-ABREAST SEATING AVAILABLE

2.4 INTERIOR ARRANGEMENTS
2.4.1 PASSENGERS
MODEL DC-9-41

135 PASSENGERS, 5-ABREAST SEATING

- 5 SEATS ON 35-IN. (88.9 CM) PITCH
- 5 SEATS ON 34-IN. (86.4 CM) PITCH
- 65 SEATS ON 33-IN. (83.8 CM) PITCH
- 60 SEATS ON 32-IN. (81.3 CM) PITCH

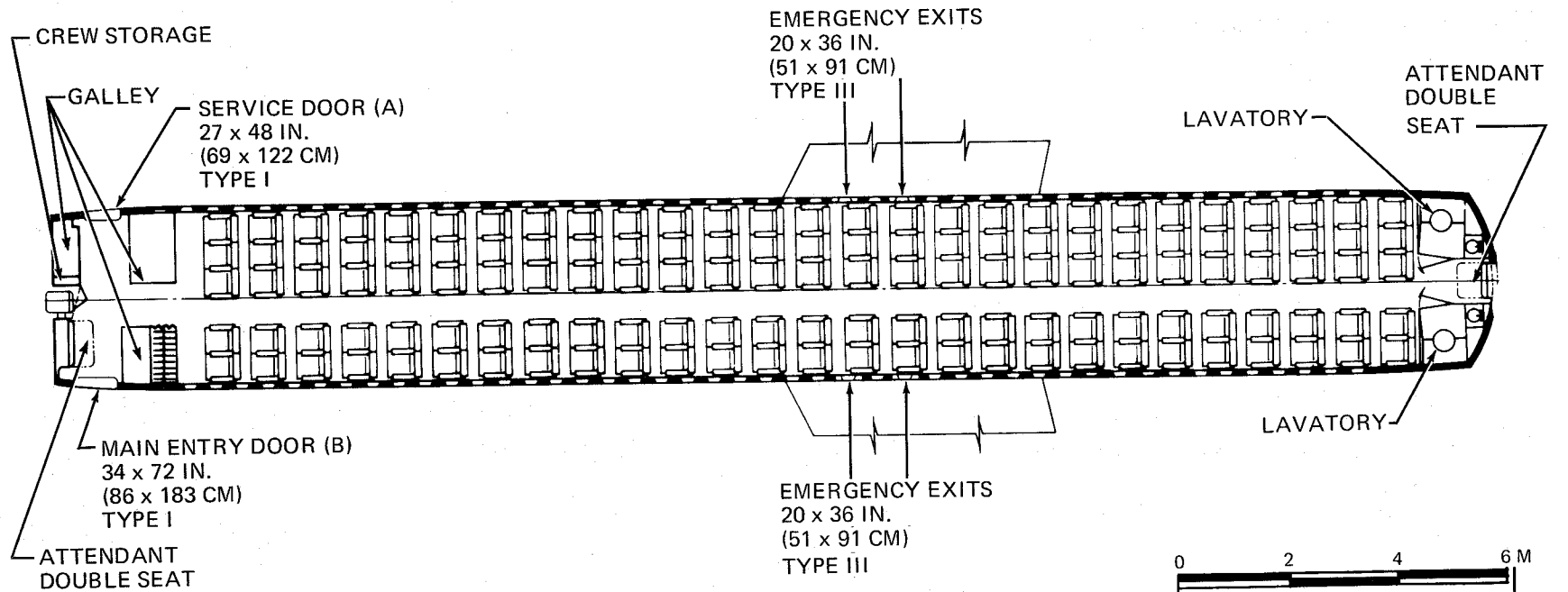

NOTE: MAXIMUM OF 139 PASSENGERS, 5- ABREAST SEATING AVAILABLE

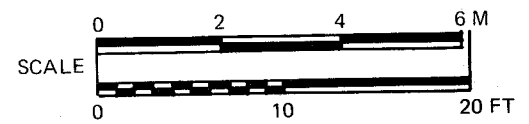

2.4 INTERIOR ARRANGEMENTS
2.4.1 PASSENGERS
MODEL DC-9-51

SERVICE DOOR (A)
27 x 48 IN.
(68.6 x 121.9 CM)
TYPE I

FORWARD CARGO
BARRIER NET

GALLEY

LAVATORY

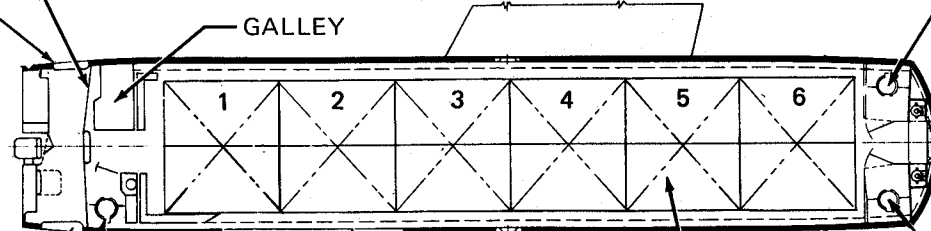

FWD ENTRY DOOR (B)
34 x 72 IN.
(86.2 x 182.9 CM)
TYPE I

CARGO DOOR (C)
81 x 136 IN.
(205.7 x 345.4 CM)

CARGO PALLETS
6 PLACES
360 FT³
(10.2 M³)
TYP

LAVATORY

LAVATORY

CARGO VOLUMES		
PALLET SIZE	NO. 1 THROUGH 6	88 x 108 IN. (224 x 274 CM)
PALLET 1 THROUGH 6		2161 FT ³ (61.2 M ³)
LOWER DECK CARGO		600 FT ³ (17.0 M ³)
TOTAL CARGO		2761 FT ³ (78.2 M ³)

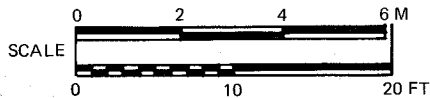

2.4 INTERIOR ARRANGEMENTS

2.4.2 CARGO

MODEL DC-9-15F

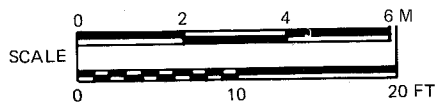
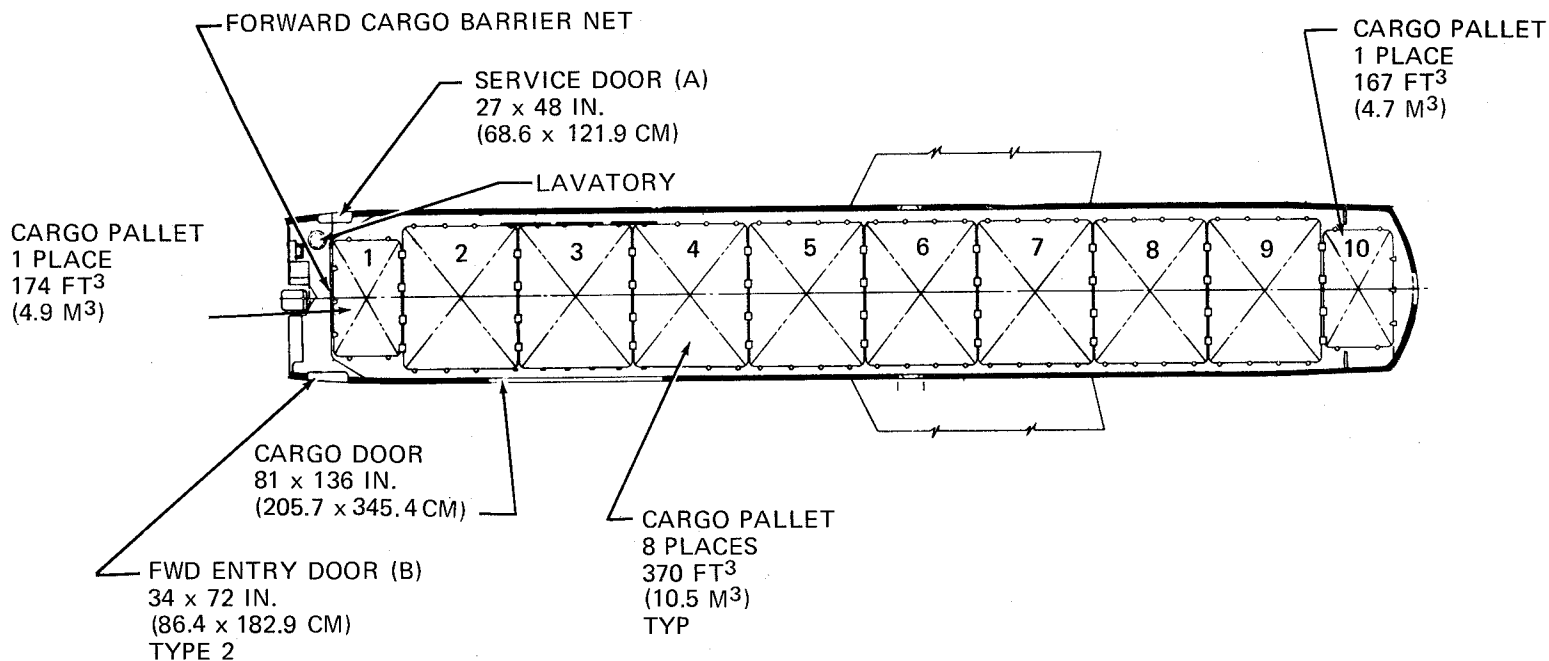

CARGO VOLUMES		
PALLET SIZES	NO. 1 AND 10,	54 x 88 IN. (137 x 224 CM)
	NO. 2 THROUGH 9	88 x 108 IN. (224 x 274 CM)
PALLET 1		174 FT ³ (4.9 M ³)
PALLETS 2 THROUGH 9		2959 FT ³ (83.8 M ³)
PALLET 10		167 FT ³ (4.7 M ³)
LOWER DECK CARGO		895 FT ³ (25.3 M ³)
TOTAL CARGO		4195 FT ³ (118.8 M ³)

2.4 INTERIOR ARRANGEMENTS

2.4.2 CARGO MODEL DC-9-32F

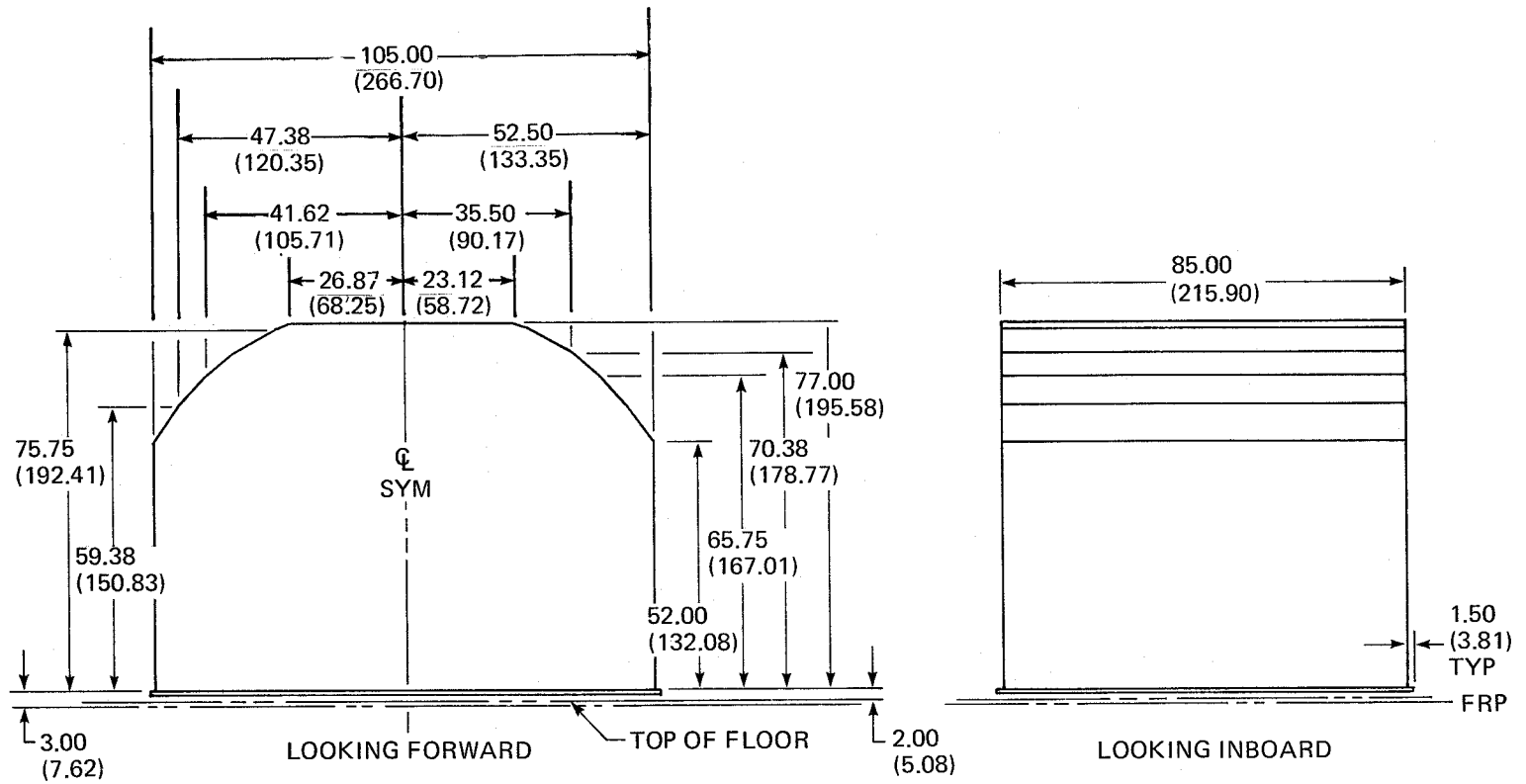

CARGO CLEARANCE 1.00 INCH (2.54 CM)
 PALLET DOUGLAS 88 x 108 IN. (223.5 x 274.3 CM)
 VOLUME 369.83 CU FT (10.47 CU M)

NOTE: MEASUREMENTS ARE IN INCHES, AND MEASUREMENTS IN PARENTHESES ARE IN CENTIMETERS

2.4 INTERIOR ARRANGEMENTS

2.4.3 PALLET ENVELOPE - CONSTANT SECTION

DC-9-15 FREIGHTER

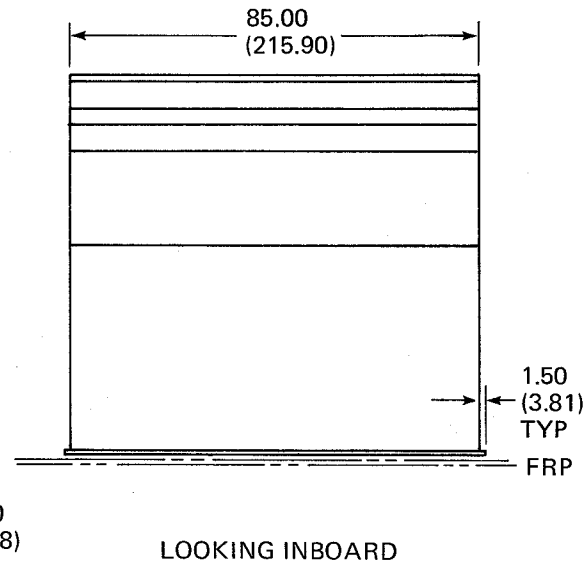
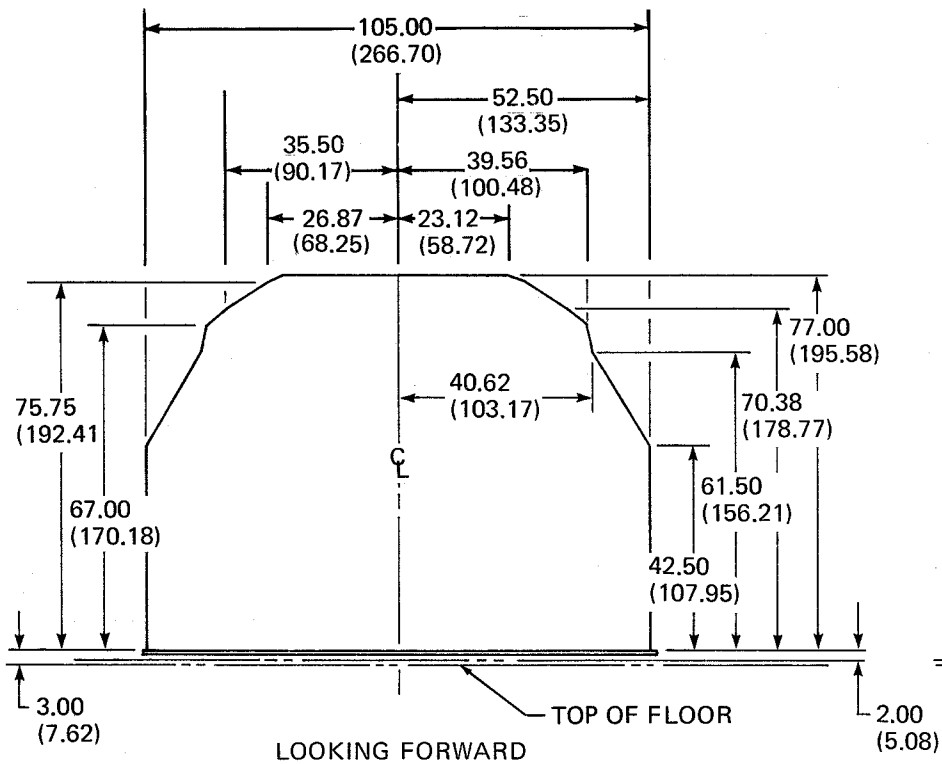

CARGO CLEARANCE 1.00 INCH (2.54 CM)
 PALLET DOUGLAS 88 x 108 IN. (223.5 x 274.3 CM)
 VOLUME 360.26 CU FT (10.20 CU M)

NOTE: MEASUREMENTS ARE IN INCHES, AND MEASUREMENTS IN PARENTHESES ARE IN CENTIMETERS

2.4 INTERIOR ARRANGEMENTS

2.4.3 PALLET ENVELOPE - CONSTANT SECTION

DC-9-32 FREIGHTER

DEEP BAGGAGE RACK – STANDARD SERIES 51 AND 80
 OPTIONAL ALL OTHER MODELS

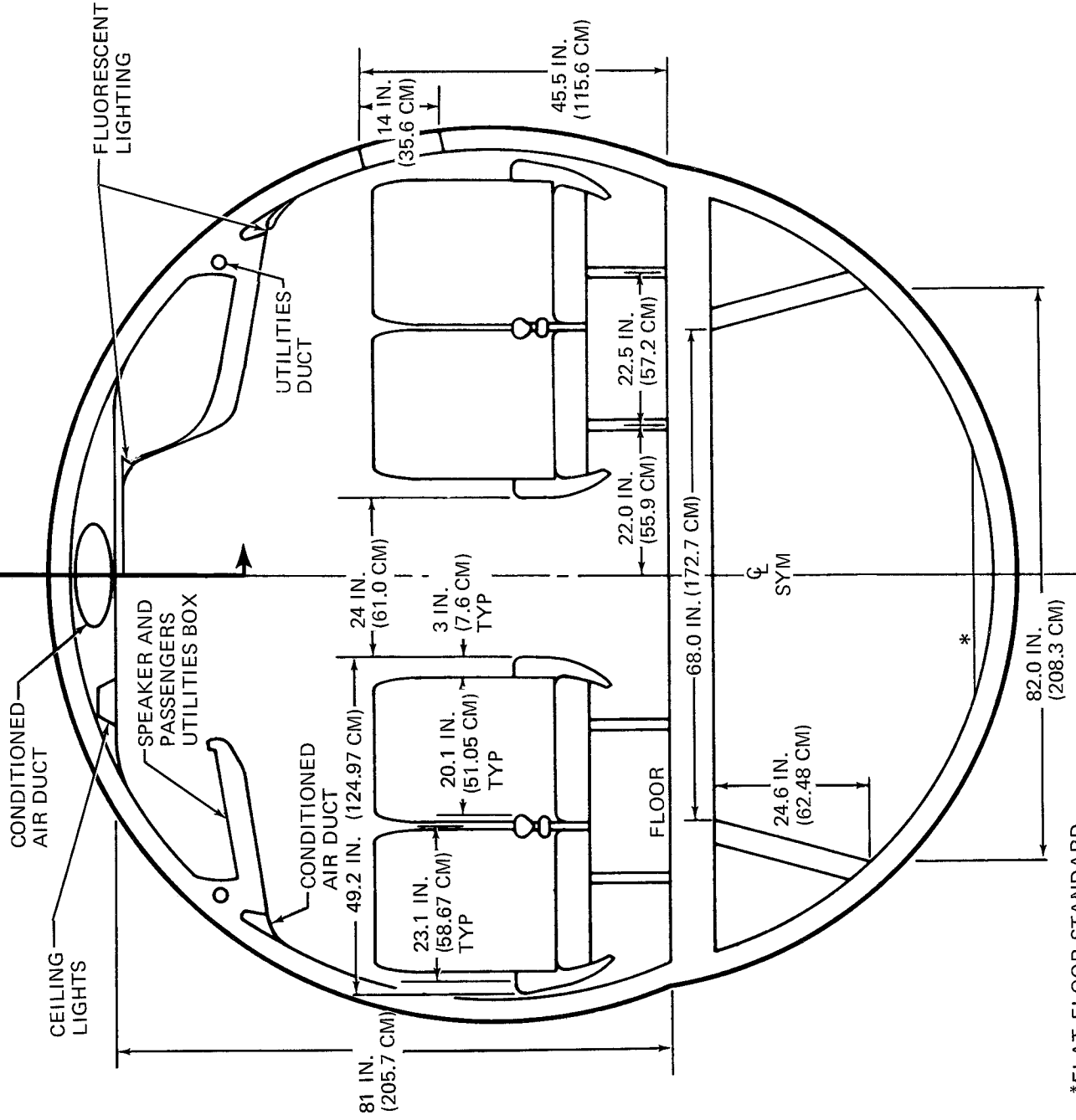

* FLAT FLOOR STANDARD
 ON DC-9-80, OPTIONAL ON
 ALL OTHER SERIES

2.5 PASSENGER CABIN CROSS SECTION 2.5.2 FIRST CLASS - MODEL DC-9

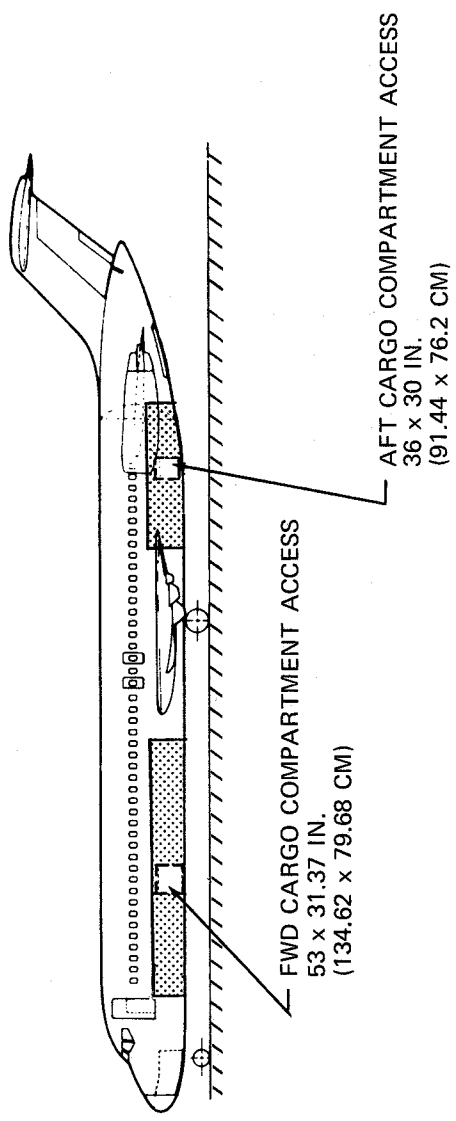

MODEL DC-9	FORWARD CARGO COMPARTMENT	AFT CARGO COMPARTMENT	TOTAL CARGO
-15	373 CU FT (10.56 CU M)	227 CU FT (6.43 CU M)	600 CU FT (17.00 CU M)
-21	373 CU FT (10.56 CU M)	227 CU FT (6.43 CU M)	600 CU FT (17.00 CU M)
-32	562 CU FT (15.91 CU M)	333 CU FT (9.43 CU M)	895 CU FT (25.34 CU M)
-41	624 CU FT (17.67 CU M)	395 CU FT (11.19 CU M)	1019 CU FT (28.86 CU M)
-51	717 CU FT (20.30 CU M)	457 CU FT (12.94 CU M)	1174 CU FT (33.24 CU M)

*WITHOUT FUSELAGE AUXILIARY FUEL TANKS

2.6 LOWER COMPARTMENTS (NO CONTAINERS) MODEL DC-9 (SERIES 15 THROUGH 51)

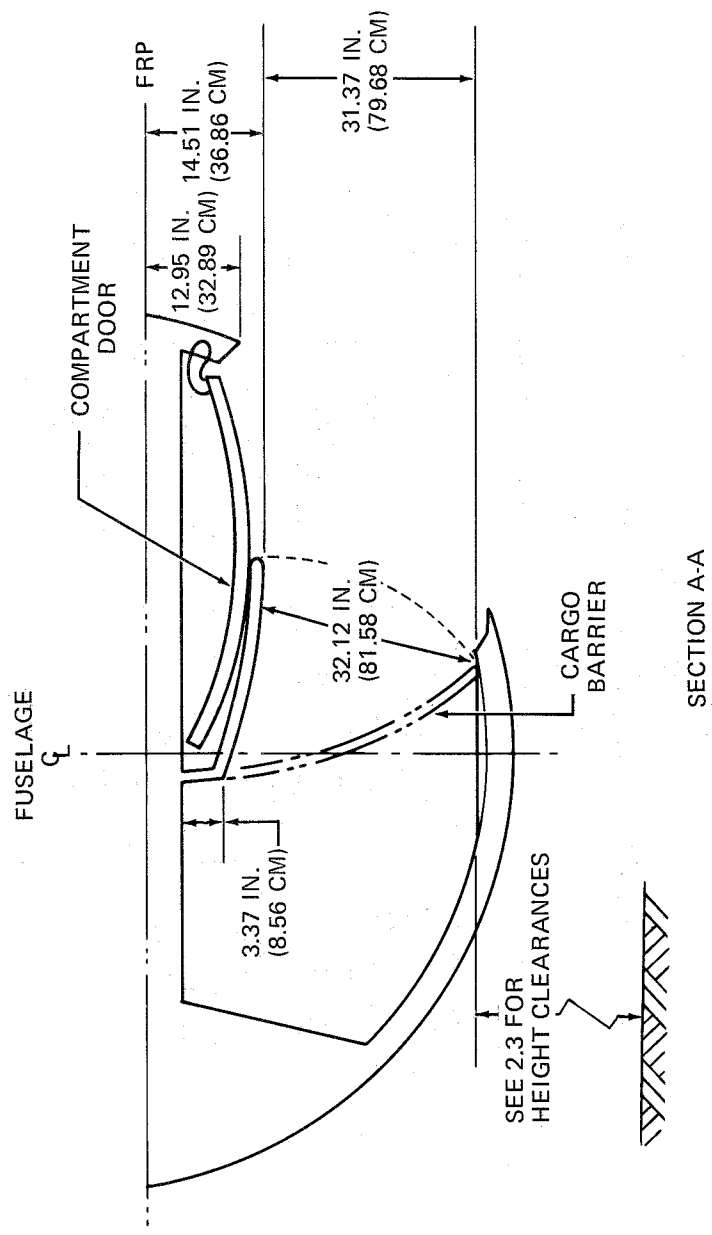
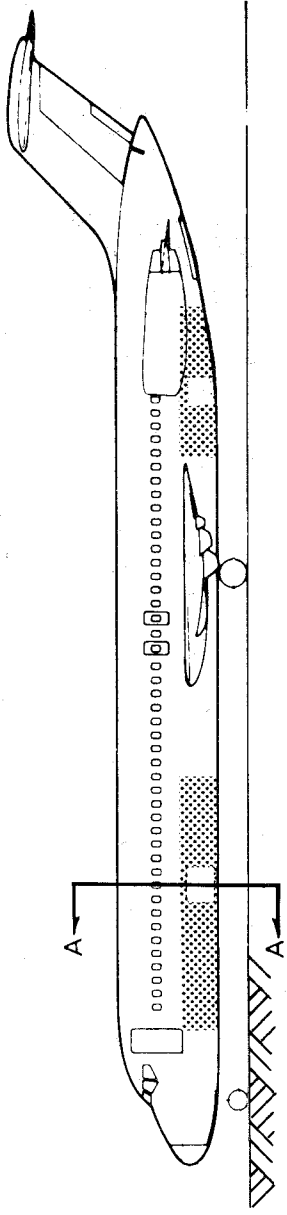

2.7 DOOR CLEARANCES

2.7.1 LOWER FORWARD CARGO DOOR CLEARANCES

MODEL DC-9 (SERIES 15 THROUGH 51)

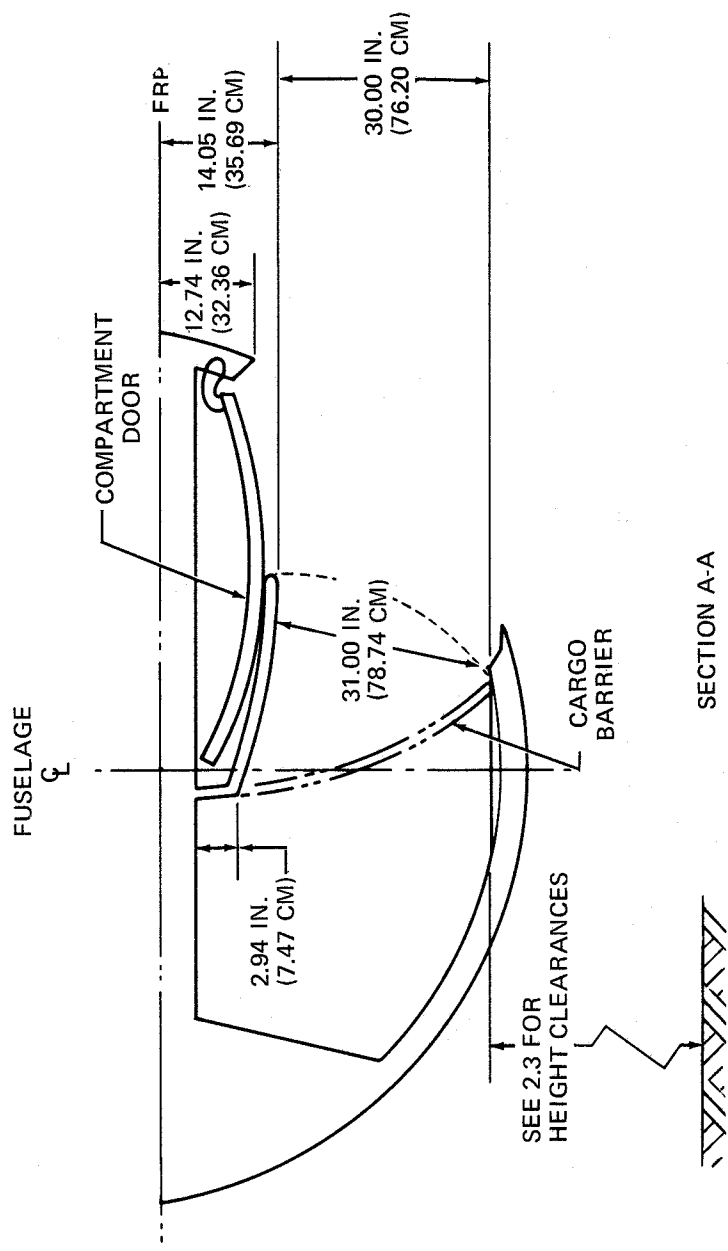
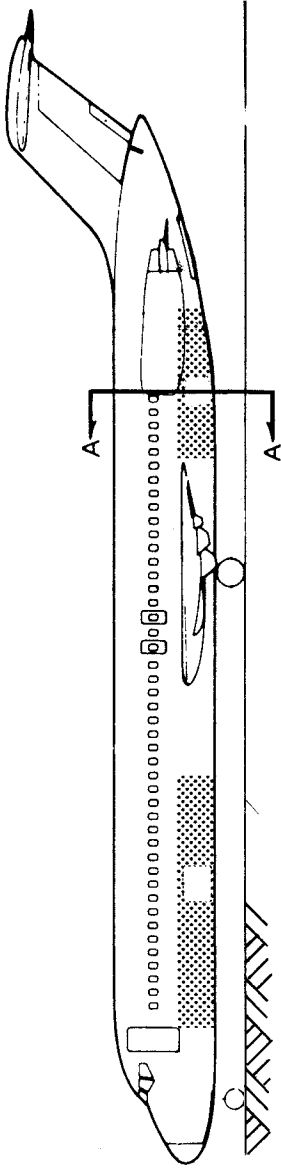

2.7 DOOR CLEARANCES

2.7.2 LOWER AFT CARGO DOOR CLEARANCES

MODEL DC-9

(SERIES 15 THROUGH 51)

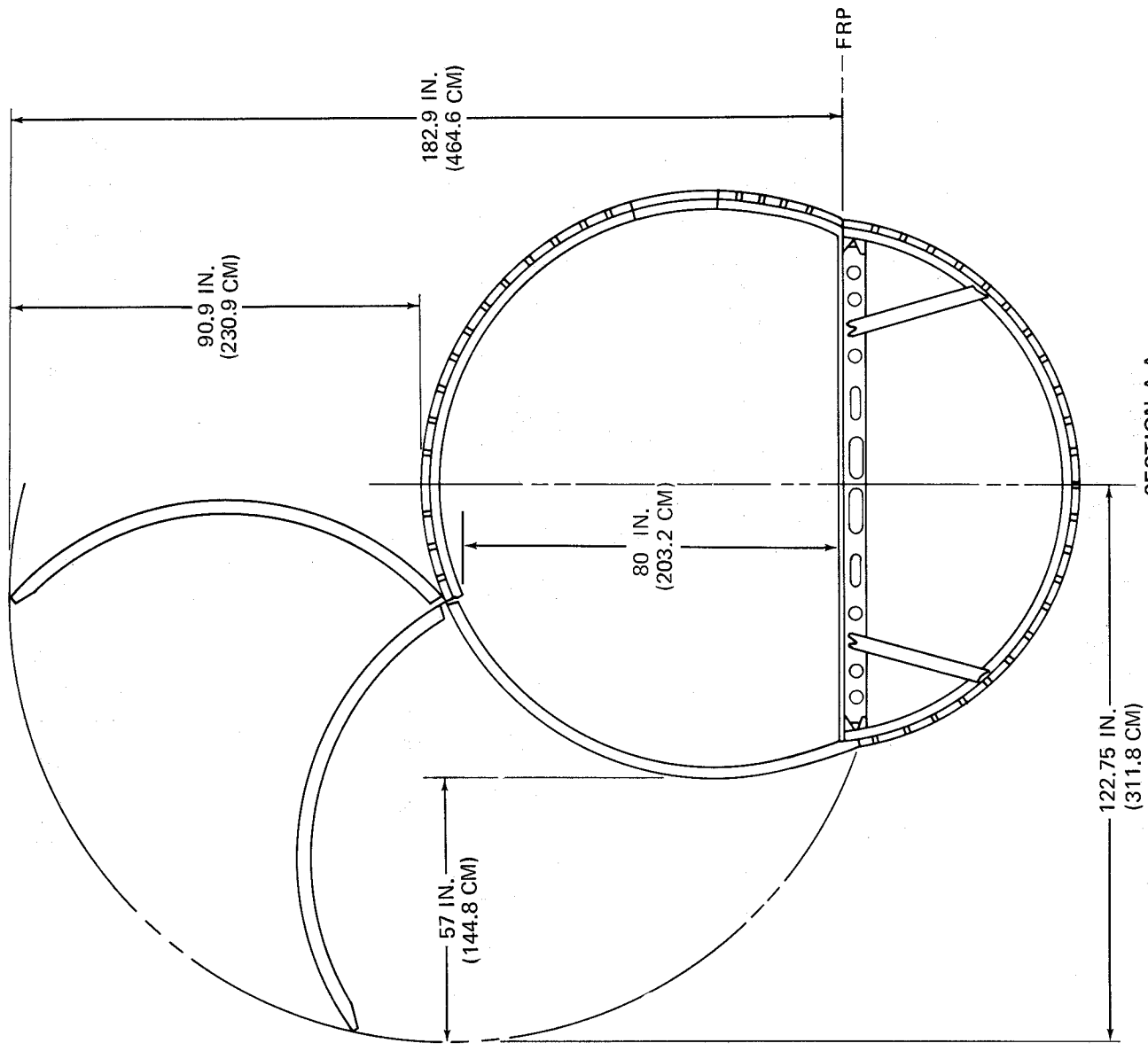
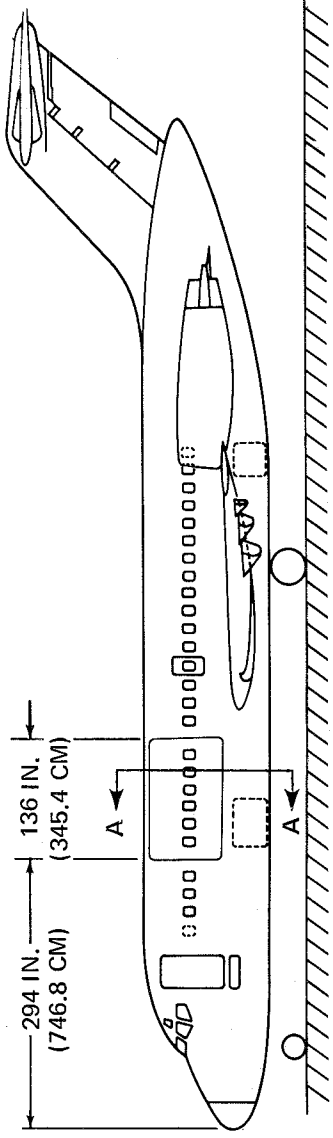

2.7 DOOR CLEARANCES
2.7.3 UPPER CARGO DOOR CLEARANCES
(MODEL DC-9-15 AND -32)

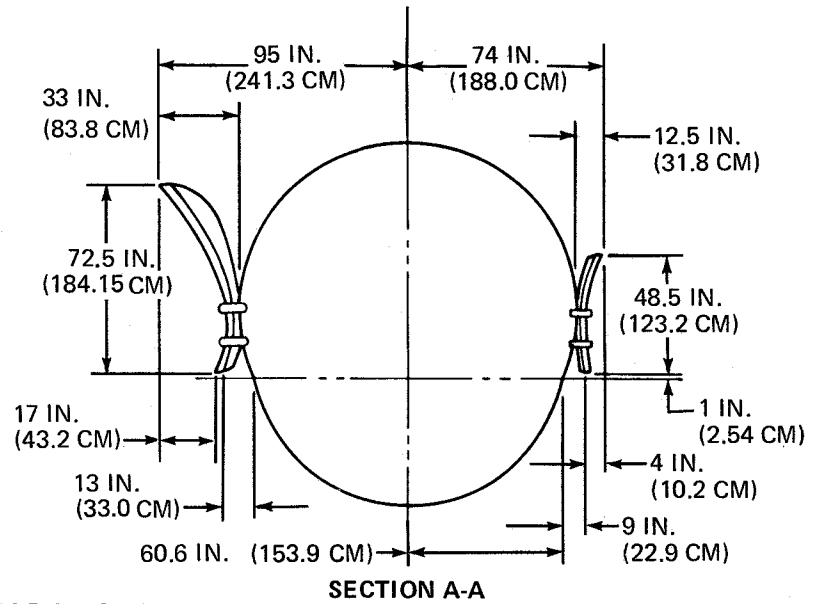
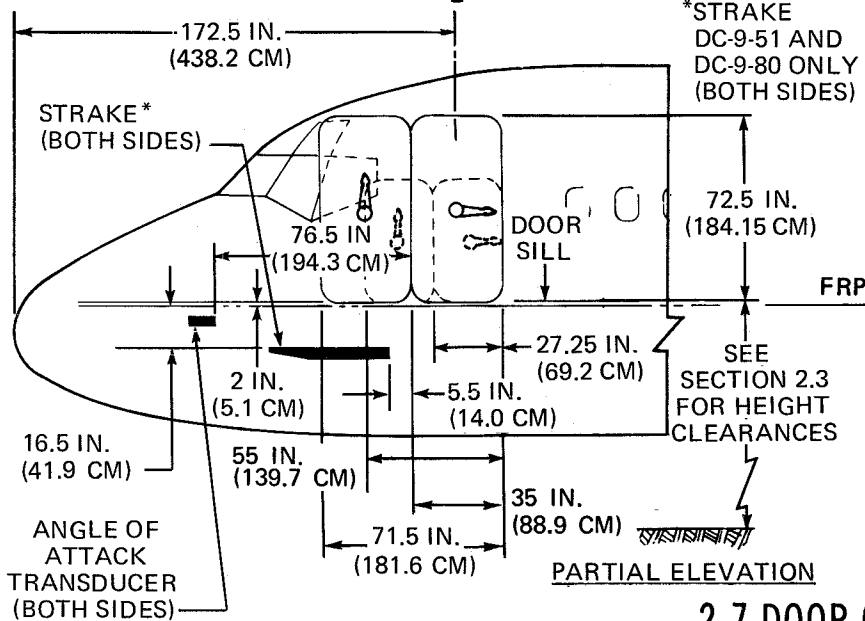
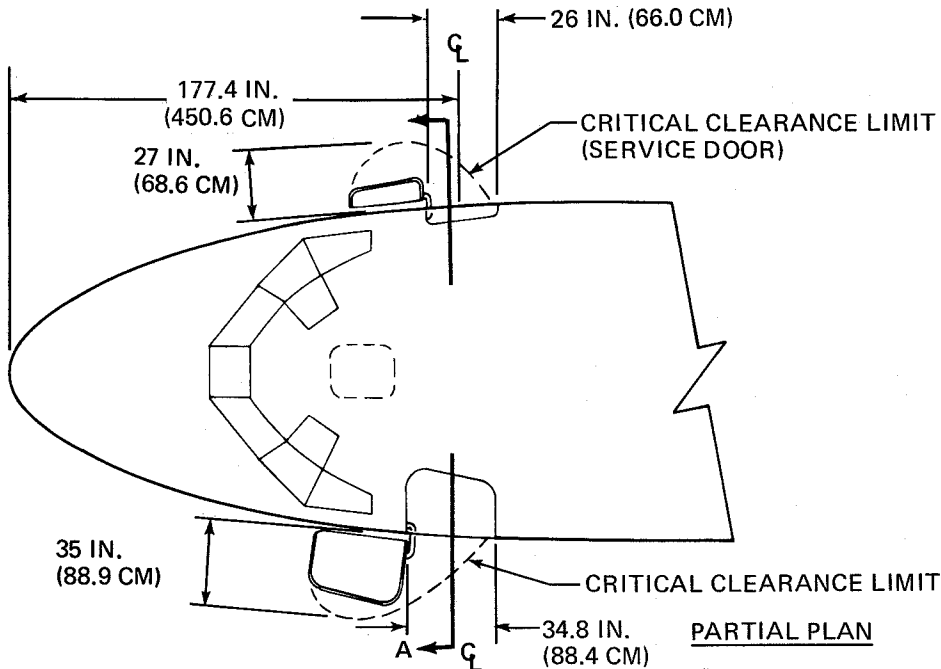

2.7 DOOR CLEARANCES
2.7.4 PASSENGER ENTRANCE AND SERVICE DOOR CLEARANCES
MODEL DC-9

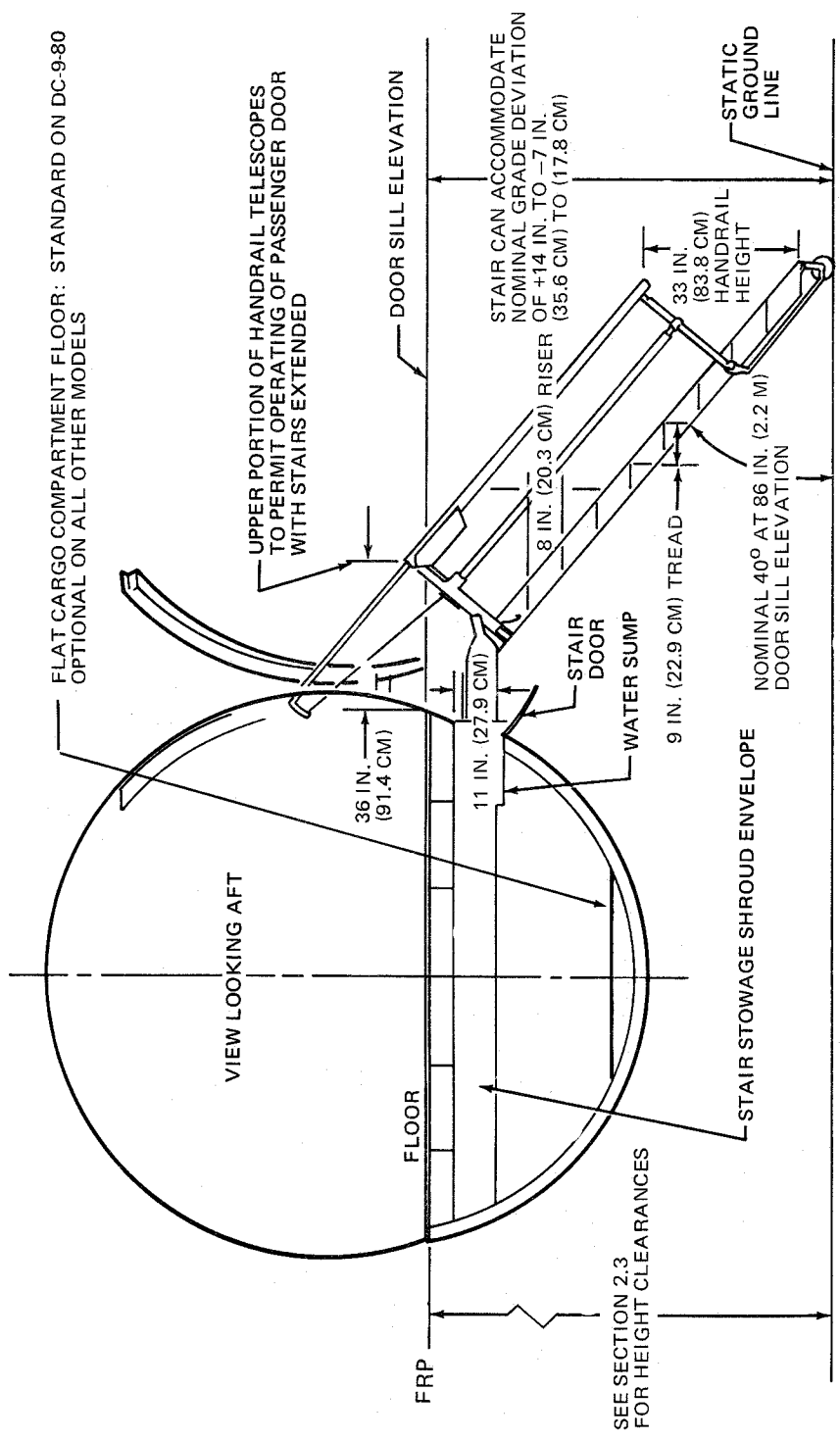

2.7 DOOR CLEARANCES

2.7.5 MAIN ENTRANCE STAIRWAY CLEARANCES MODEL DC-9

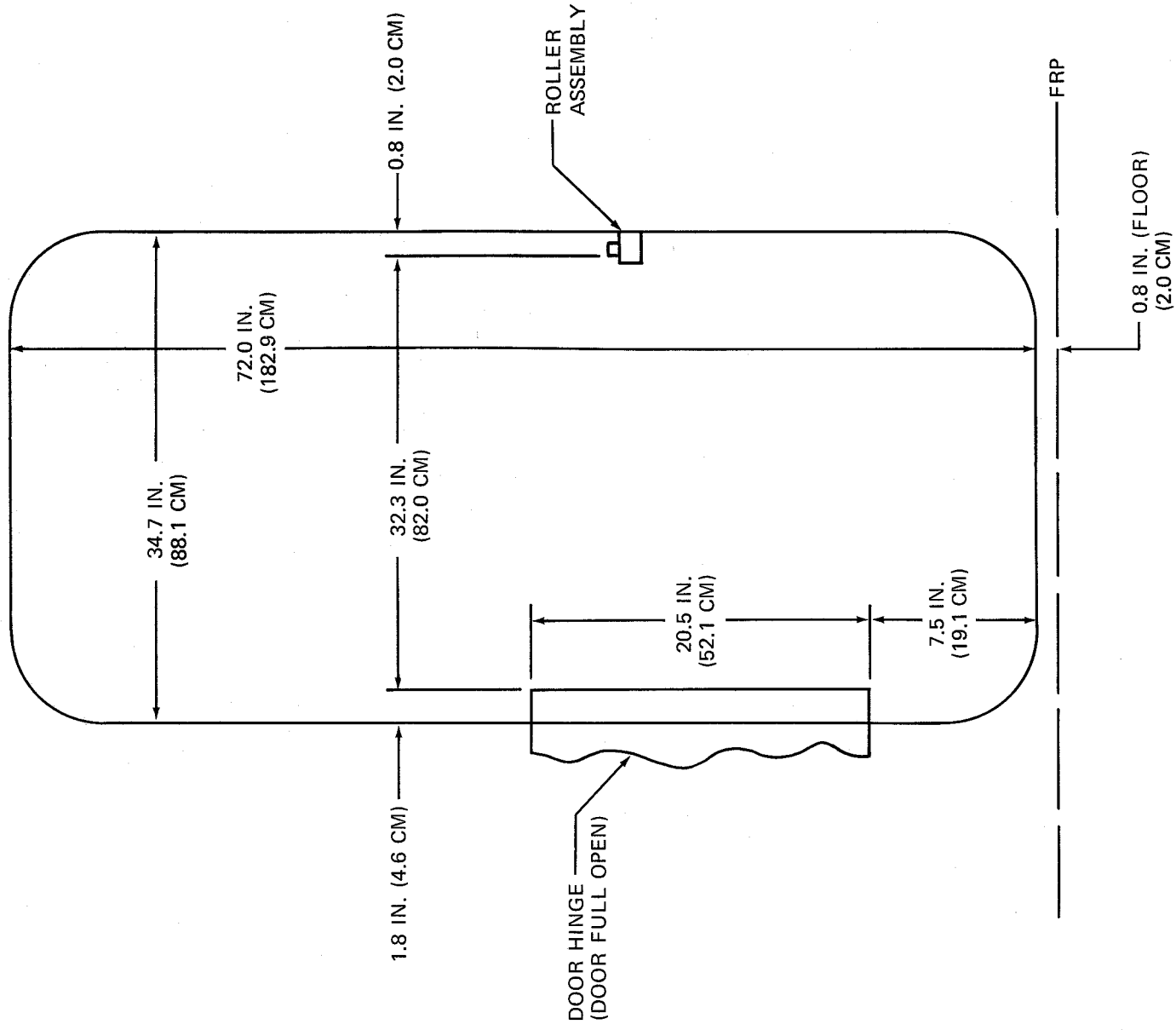

2.7 DOOR CLEARANCES
2.7.6 FORWARD PASSENGER DOOR OPENING
CLEARANCES
MODEL DC-9

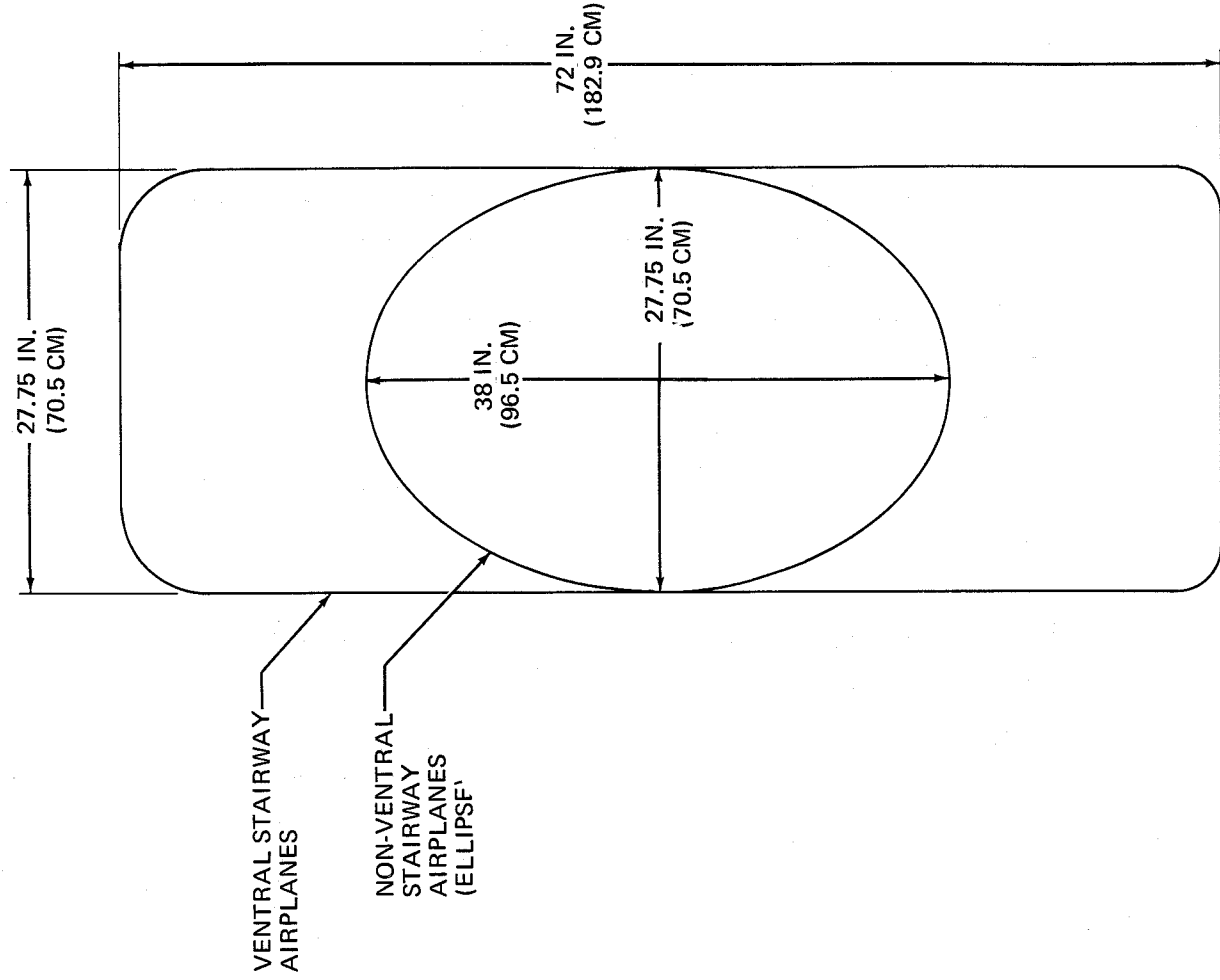

2.7 DOOR CLEARANCES
 2.7.6 FORWARD PASSENGER DOOR OPENING CLEARANCES
 MODEL DC-9

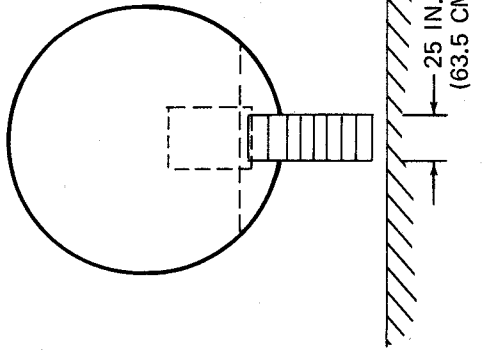
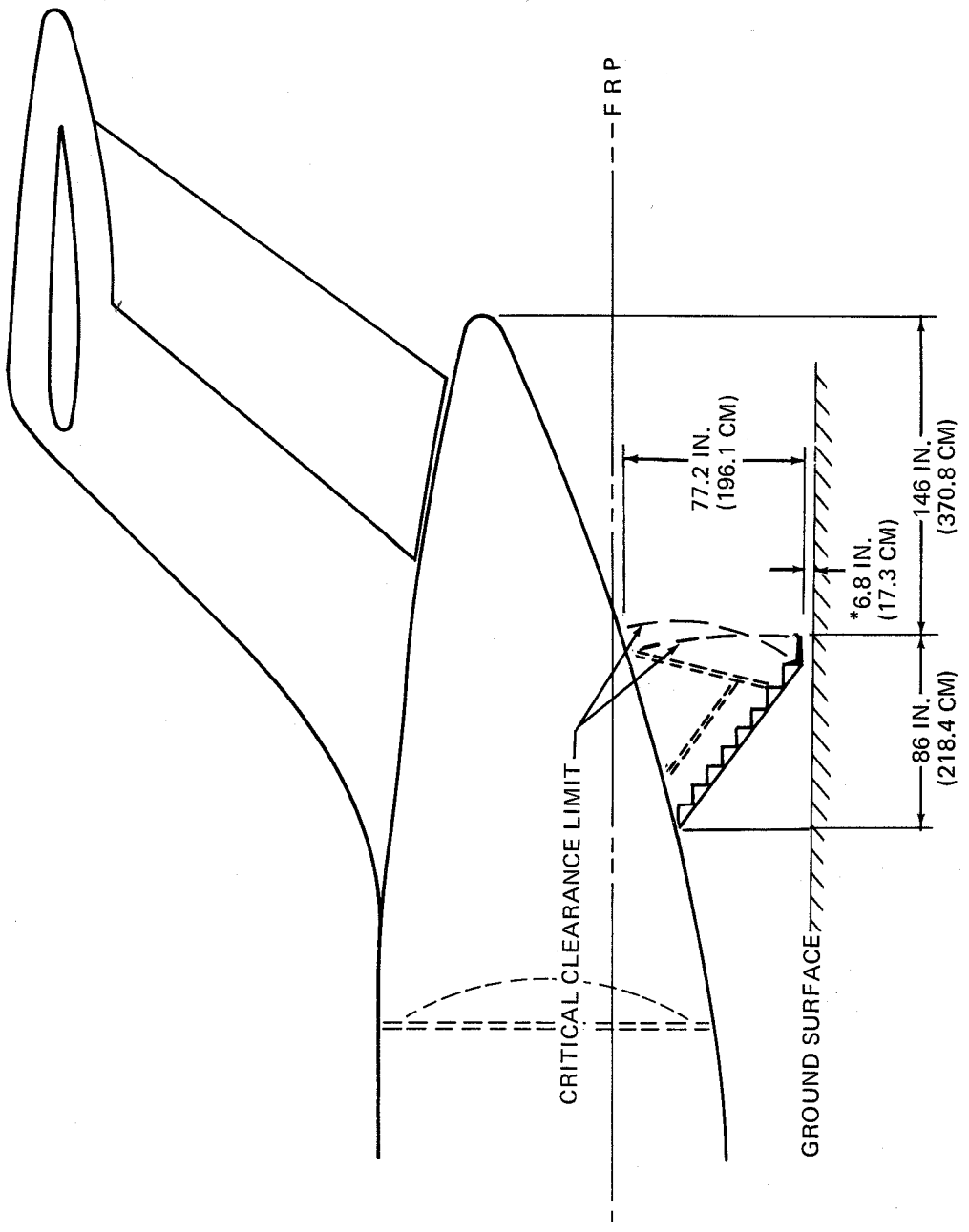

*VARIES WITH MODEL, WEIGHT, CG LOCATION, AND LANDING GEAR STRUT COMPRESSION.

2.7 DOOR CLEARANCES
2.7.8 VENTRAL STAIR CLEARANCES
MODEL DC-9
(SERIES 15 THROUGH 51)

3.0 AIRPLANE PERFORMANCE

- 3.1 General Information**
- 3.2 Payload Range**
- 3.3 FAR Takeoff Runway Length Requirements**
- 3.4 FAR Landing Runway Length Requirements**

3.0 TAKEOFF AND LANDING REQUIREMENTS

3.1 General Information

Figure 3.2 presents payload-range information for a specific long-range cruise altitude and at the fuel reserve condition shown.

Figures 3.3 and 3.4 represent FAR takeoff and landing field length requirements for FAA certification.

Standard day temperatures for the altitudes shown are tabulated below:

ELEVATION		STANDARD DAY TEMP	
FEET	METERS	°F	°C
0	0	59.0	15.0
2000	610	51.9	11.1
4000	1219	44.7	7.1
6000	1829	37.6	3.1
8000	2438	30.5	-0.8

NOTE: Information presented for standard engines for given model. Engine options are available.

NOTE: DOMESTIC RESERVES AT
200 NAUTICAL MILES ALTERNATE
PLUS 45 MINUTES AT LRC

- STANDARD DAY
- NO WIND
- OEW = 49,162 POUNDS
- JT8D - 1 ENGINE

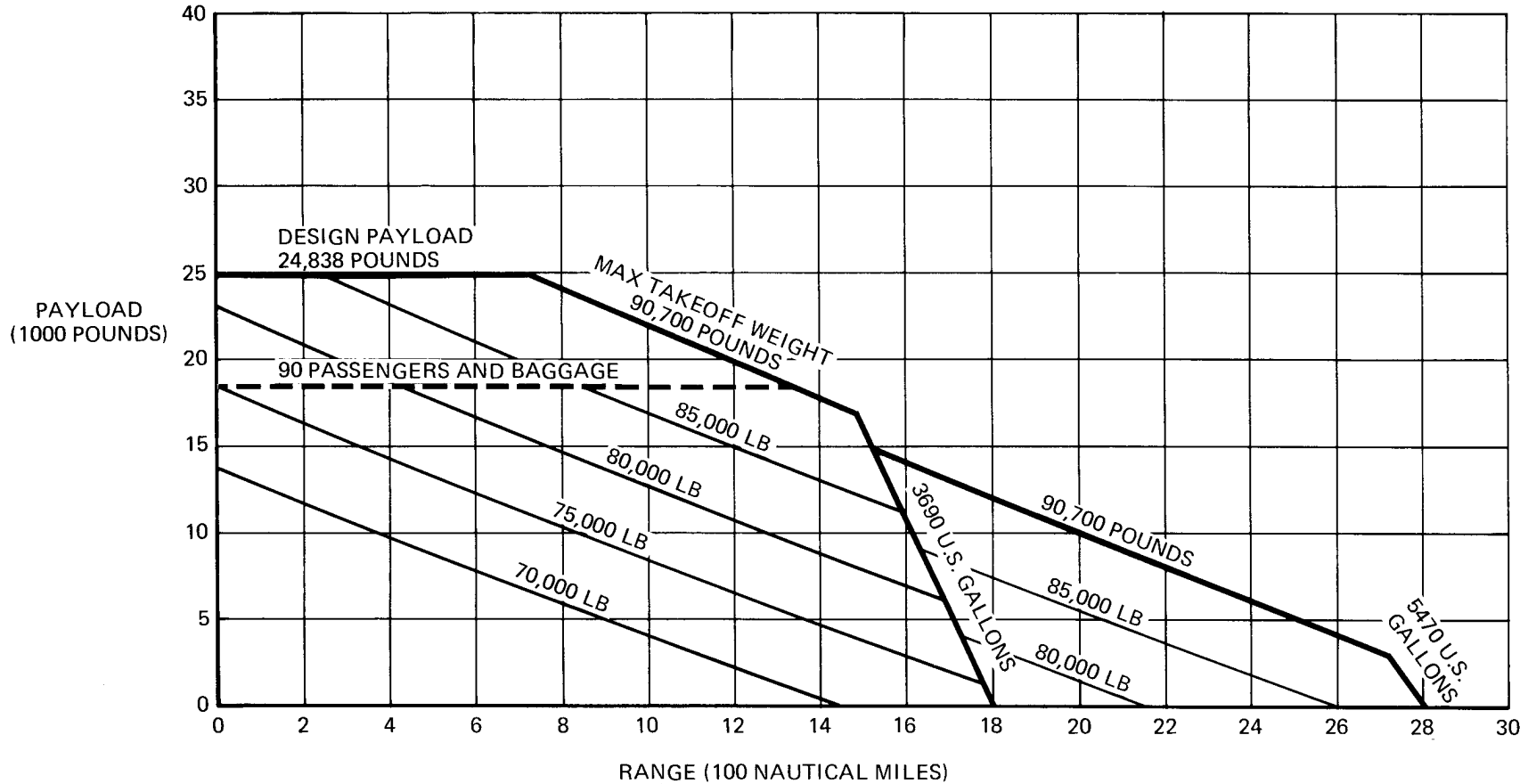

3.2 PAYLOAD-RANGE
PAYLOAD-RANGE FOR LONG-RANGE CRUISE AT 30,000 FT
MODEL DC-9-15

NOTE: DOMESTIC RESERVES AT
200 NAUTICAL MILES ALTERNATE
PLUS 45 MINUTES AT LRC

- STANDARD DAY
- NO WIND
- OEW = 22,300 KG
- JT8D - 1 ENGINE

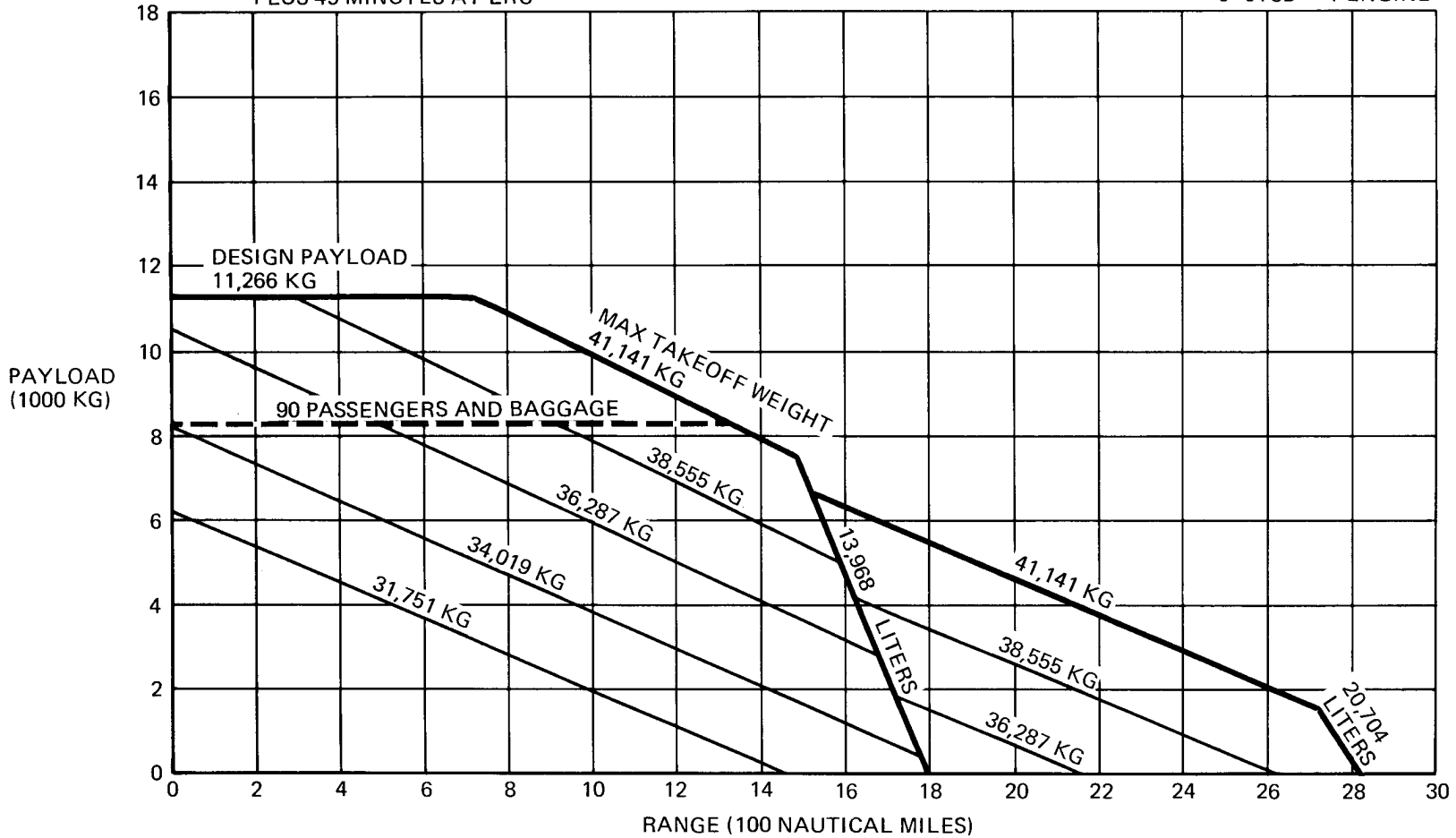

3.2 PAYLOAD-RANGE
PAYLOAD-RANGE FOR LONG-RANGE CRUISE AT 9,150 METERS
DC-9-15

NOTE: DOMESTIC RESERVES AT
200 NAUTICAL MILES ALTERNATE
PLUS 45 MINUTES AT LRC

- STANDARD DAY
- NO WIND
- OEW = 22,300 KG
- JT8D - 1 ENGINE

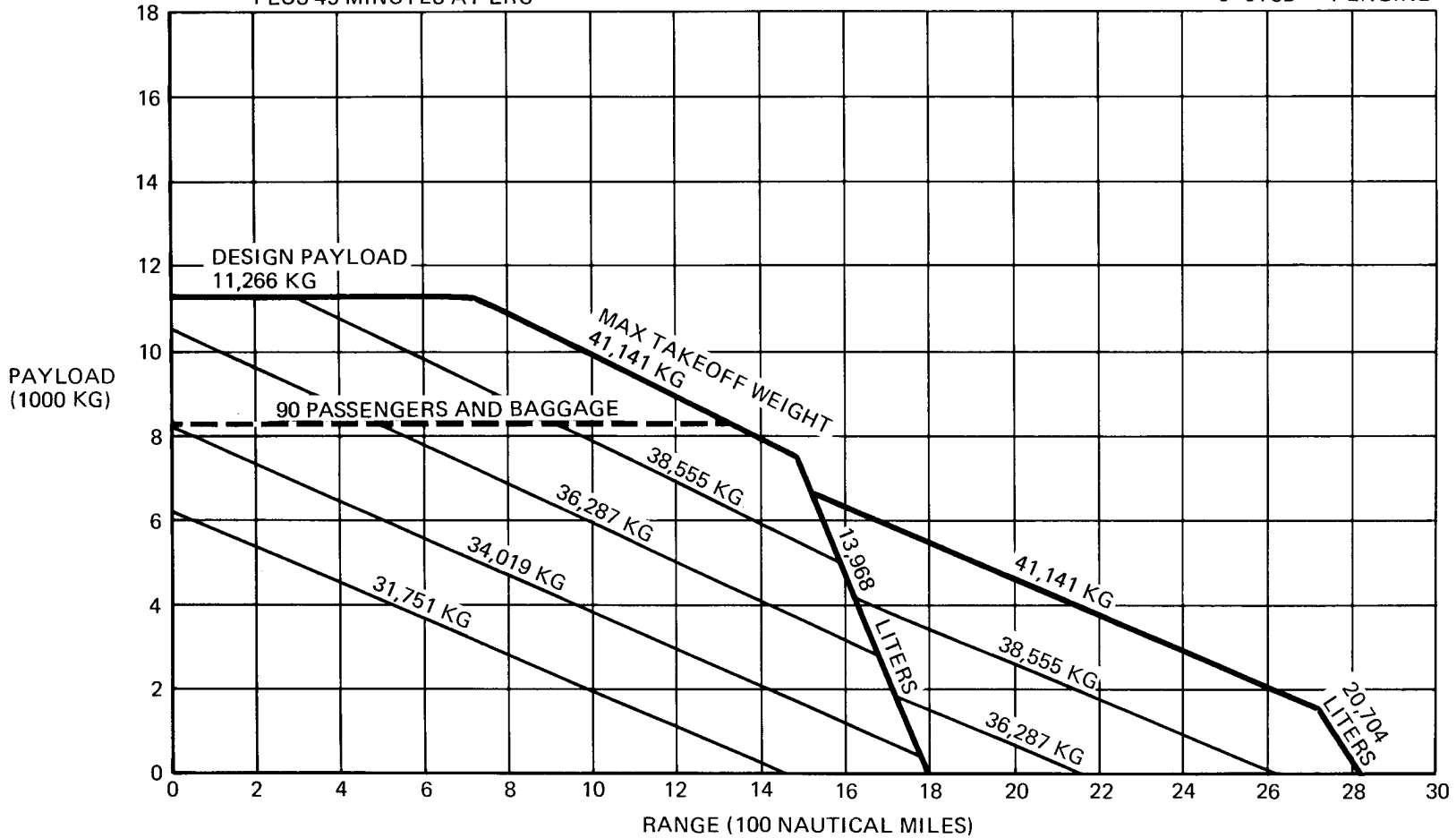

3.2 PAYLOAD-RANGE
PAYLOAD-RANGE FOR LONG-RANGE CRUISE AT 9,150 METERS
DC-9-15

NOTE: DOMESTIC RESERVES AT
200 NAUTICAL MILES ALTERNATE
PLUS 45 MINUTES AT LRC

- STANDARD, DAY
- NO WIND
- OEW = 52,644 POUNDS
- JT8D - 11 ENGINES

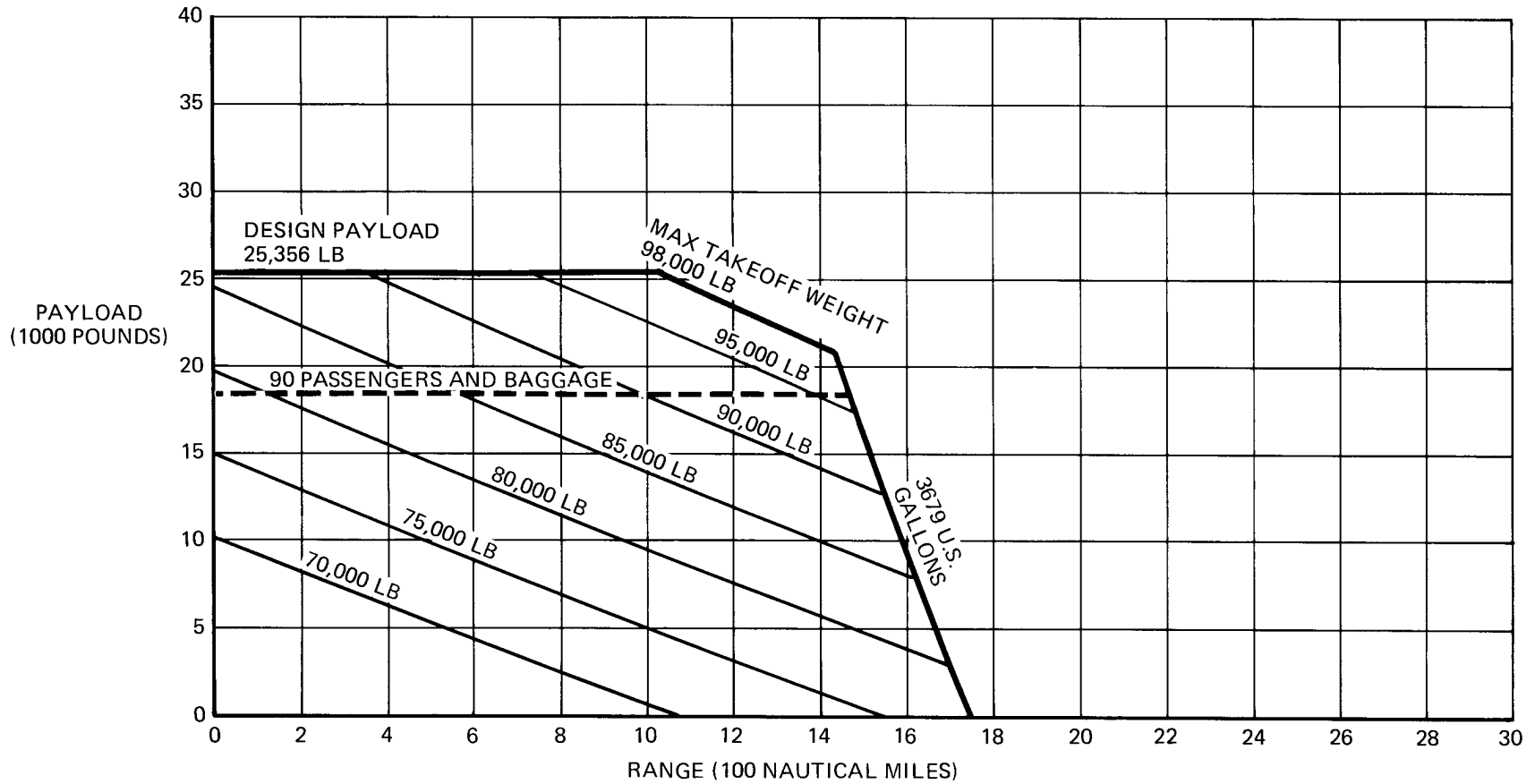

3.2 PAYLOAD-RANGE
PAYLOAD-RANGE FOR TYPICAL LONG-RANGE CRUISE AT 30,000 FT
MODEL DC-9-21

NOTE: DOMESTIC RESERVES AT
200 NAUTICAL MILES ALTERNATE
PLUS 45 MINUTES AT LRC

- STANDARD DAY
- NO WIND
- OEW = 23,879 KG
- JT8D – 11 ENGINES

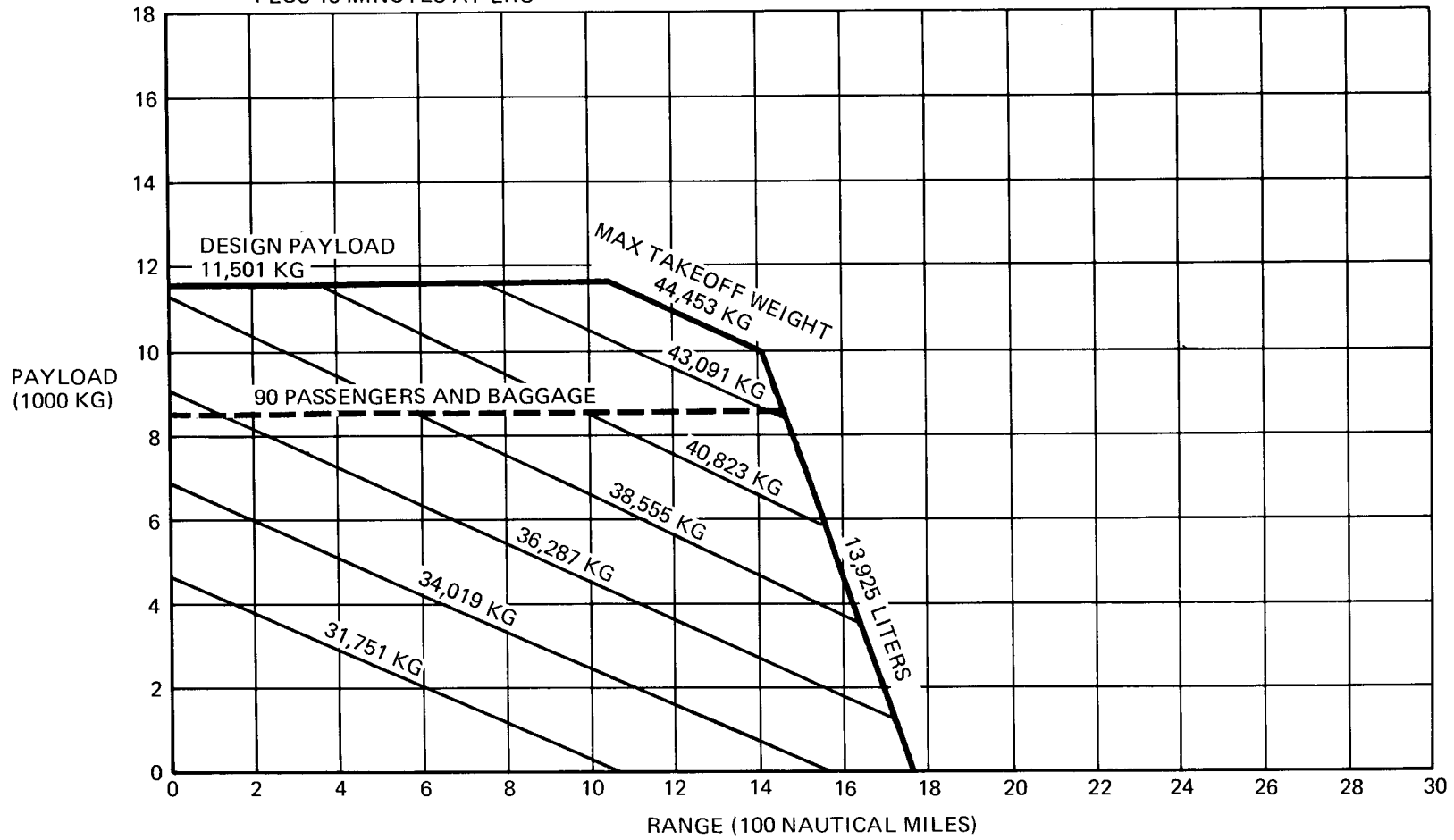

3.2 PAYLOAD-RANGE
PAYLOAD-RANGE FOR TYPICAL LONG-RANGE CRUISE AT 9150 METERS
MODEL DC-9-21

NOTE: DOMESTIC RESERVES AT
200 NAUTICAL MILES ALTERNATE
PLUS 45 MINUTES AT LRC

- STANDARD DAY
- NO WIND
- OEW = 25,789 KG
- JT8D-7 ENGINES

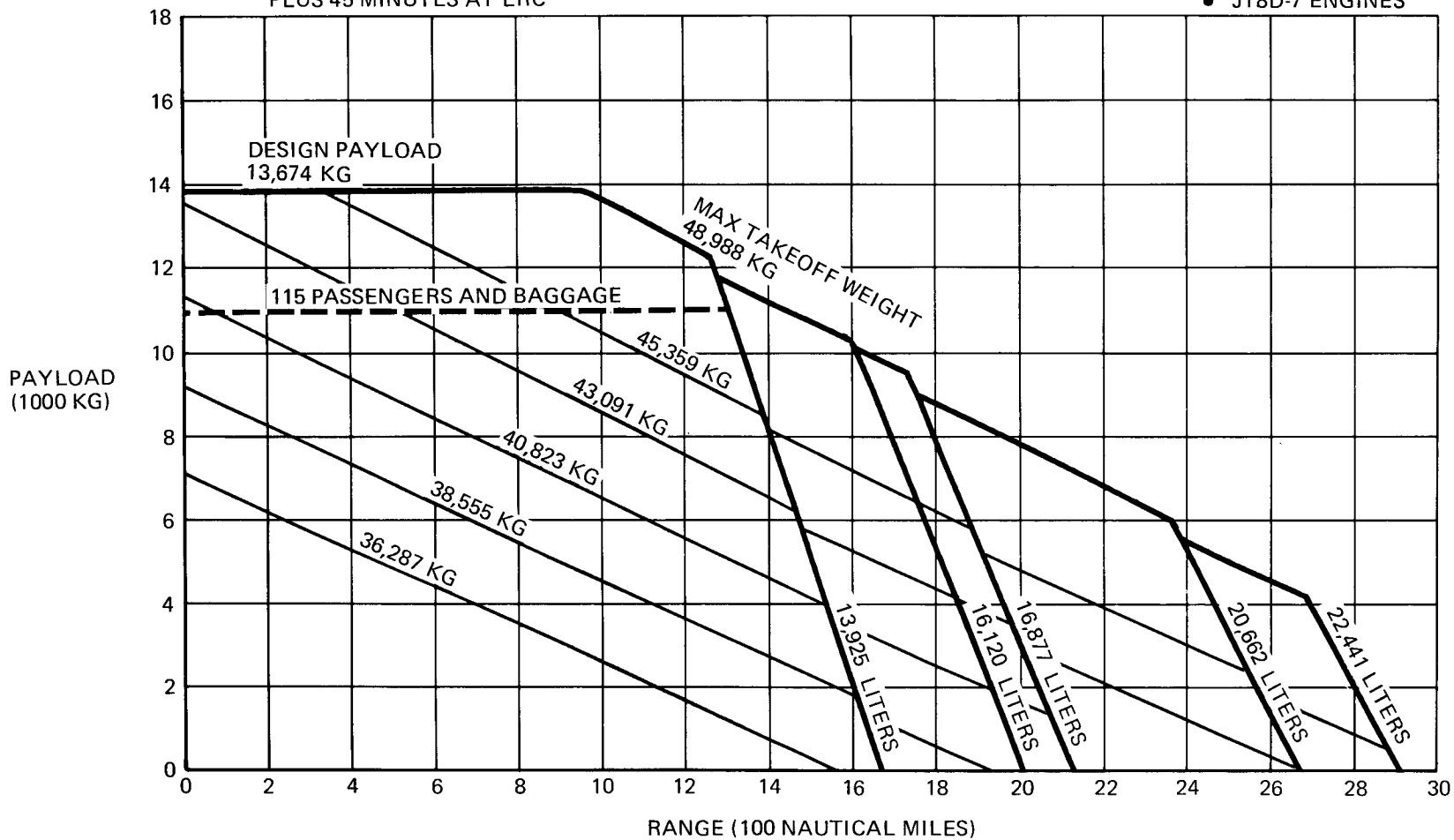

3.2 PAYLOAD-RANGE
PAYLOAD-RANGE FOR TYPICAL LONG-RANGE CRUISE AT 9,150 METERS
MODEL DC-9-32

NOTE: DOMESTIC RESERVES AT
200 NAUTICAL MILES ALTERNATE
PLUS 45 MINUTES AT LRC

- STANDARD DAY
- NO WIND
- OEW = 56,855 POUNDS
- JT8D - 7 ENGINES

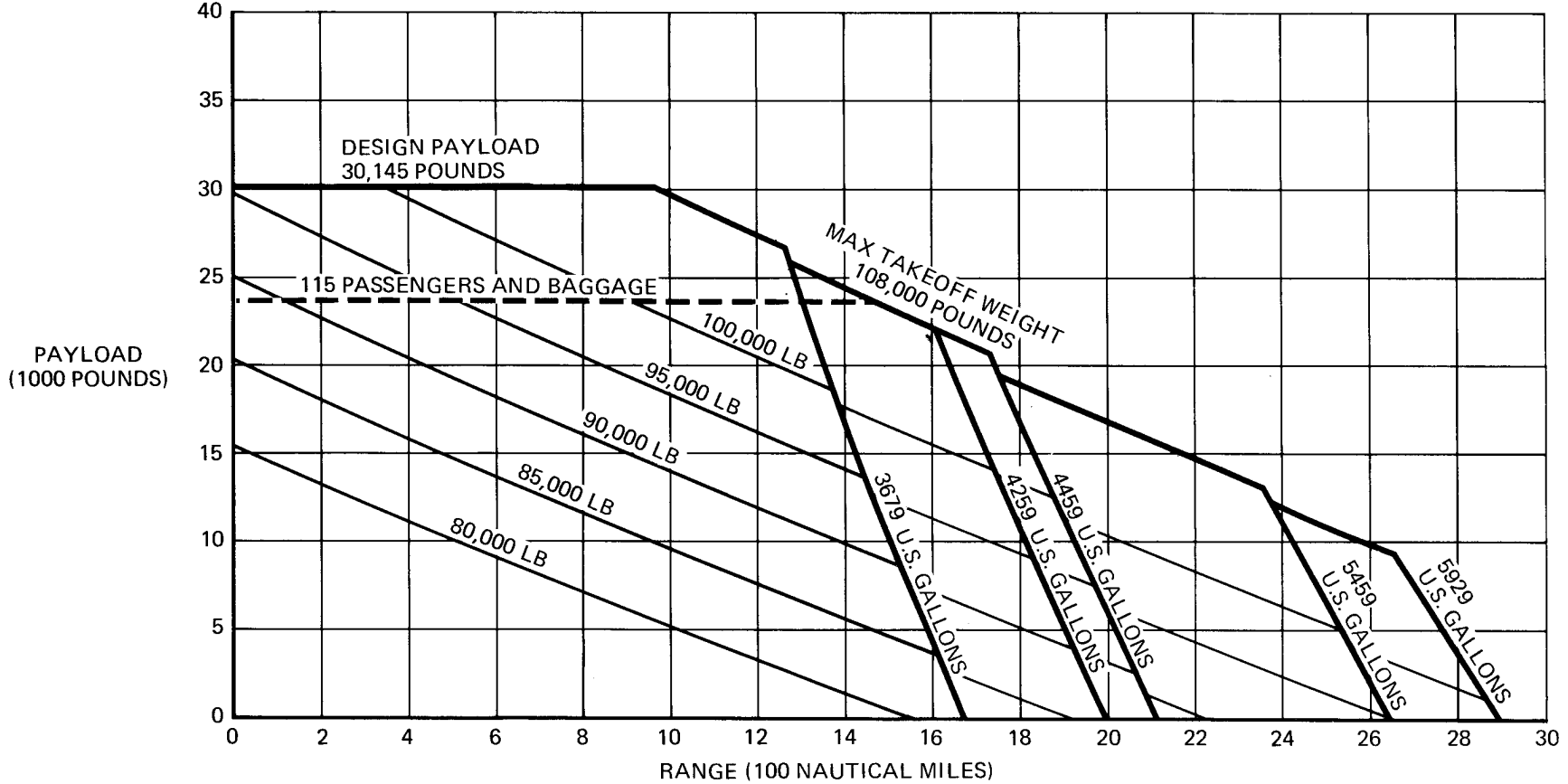

3.2 PAYLOAD-RANGE

PAYLOAD-RANGE FOR TYPICAL LONG-RANGE CRUISE AT 30,000 FT
MODEL DC-9-32

NOTE: DOMESTIC RESERVES AT
200 NAUTICAL MILES ALTERNATE
PLUS 45 MINUTES AT LRC

- STANDARD DAY
- NO WIND
- OEW = 61,335 POUNDS
- JT8D - 15 ENGINES

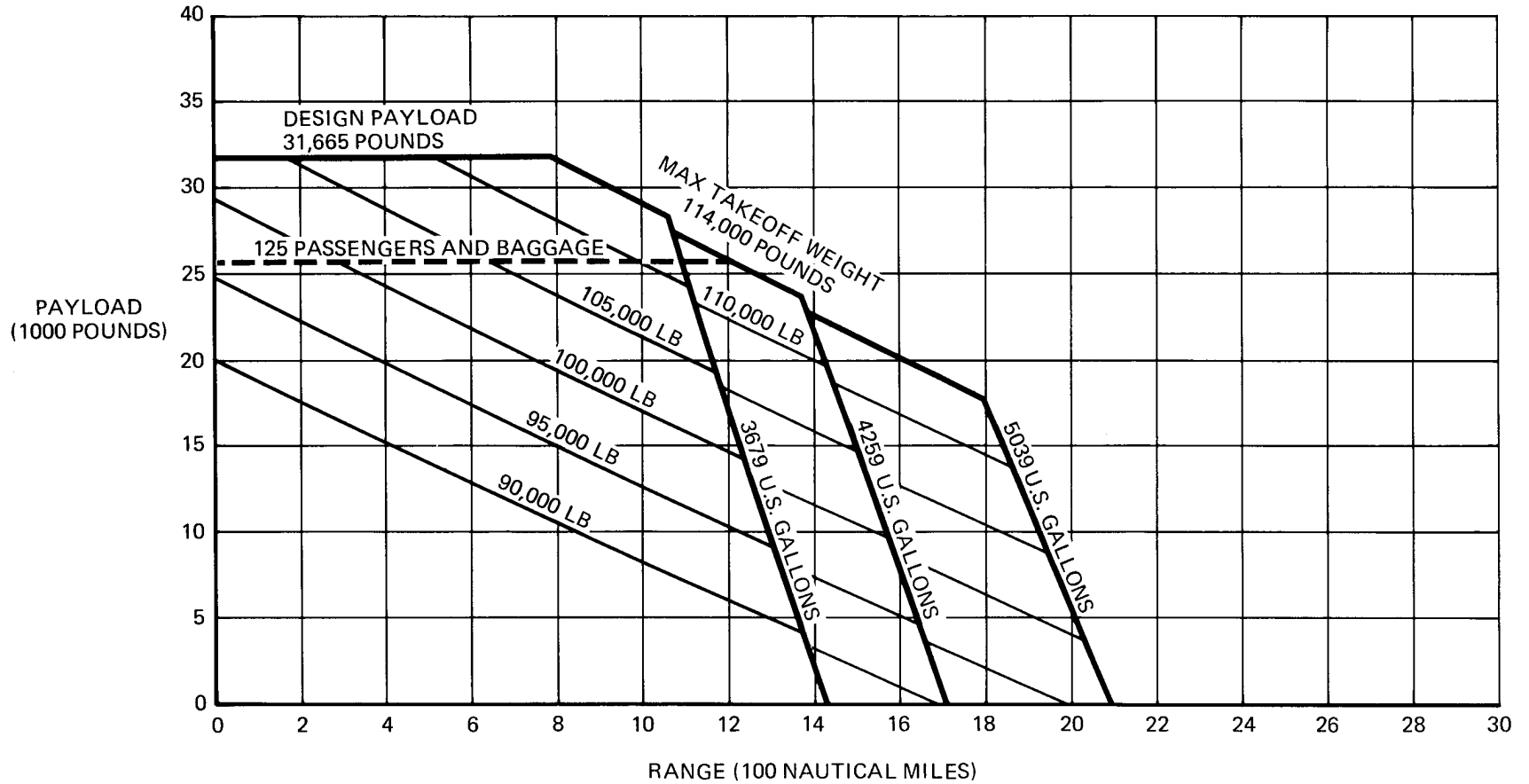

3.2 PAYLOAD-RANGE

PAYLOAD-RANGE FOR TYPICAL LONG-RANGE CRUISE AT 30,000 FT
MODEL DC-9-41

NOTE: DOMESTIC RESERVES AT
200 NAUTICAL MILES ALTERNATE
PLUS 45 MINUTES AT LRC

- STANDARD DAY
- NO WIND
- OEW = 27,821 KG
- JT8D – 15 ENGINES

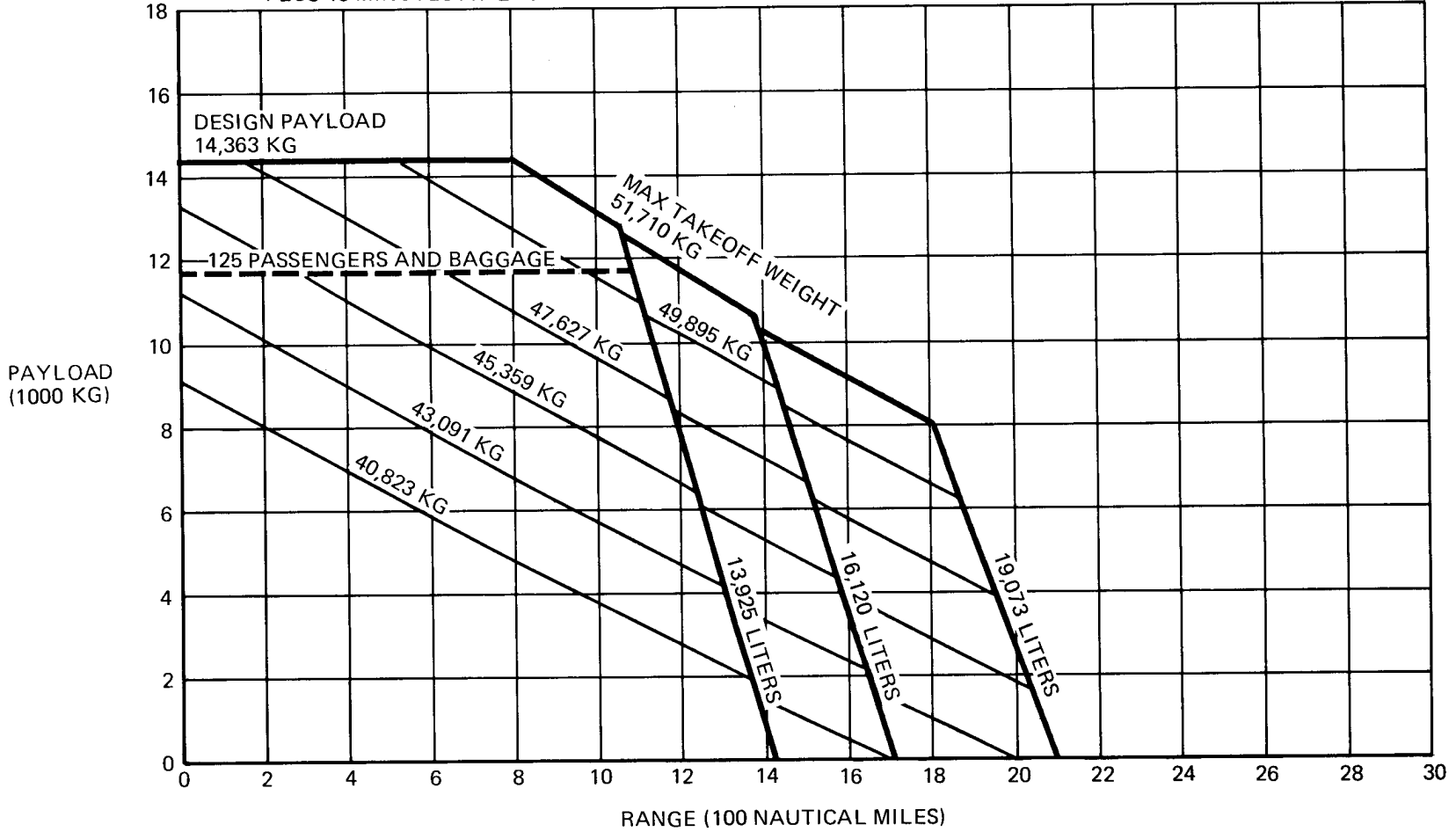

3.2 PAYLOAD-RANGE
PAYLOAD-RANGE FOR TYPICAL LONG-RANGE CRUISE AT 9,150 METERS
MODEL DC-9-41

NOTE: DOMESTIC RESERVES AT
200 NAUTICAL MILES ALTERNATE
PLUS 45 MINUTES AT LRC

- STANDARD DAY
- NO WIND
- OEW = 64,675 POUNDS
- JT8D – 17 ENGINES

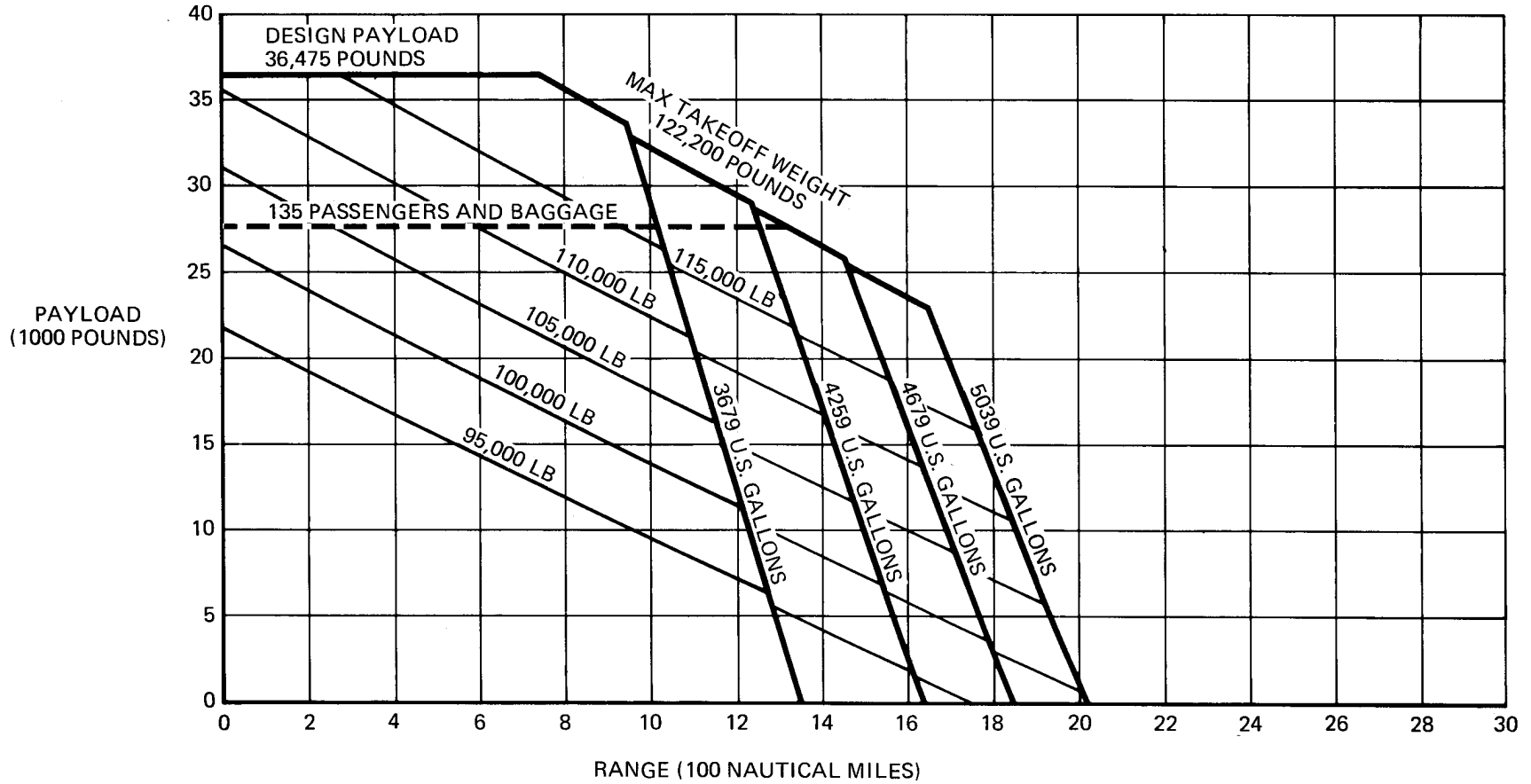

3.2 PAYLOAD-RANGE
PAYLOAD-RANGE FOR TYPICAL LONG-RANGE CRUISE AT 30,000 FT
MODEL DC-9-51

NOTE: DOMESTIC RESEVES AT
200 NAUTICAL MILES ALTERNATE
PLUS 45 MINUTES AT LRC

- STANDARD DAY
- NO WIND
- OEW = 29,336 KG)
- JT8D -17 ENGINES

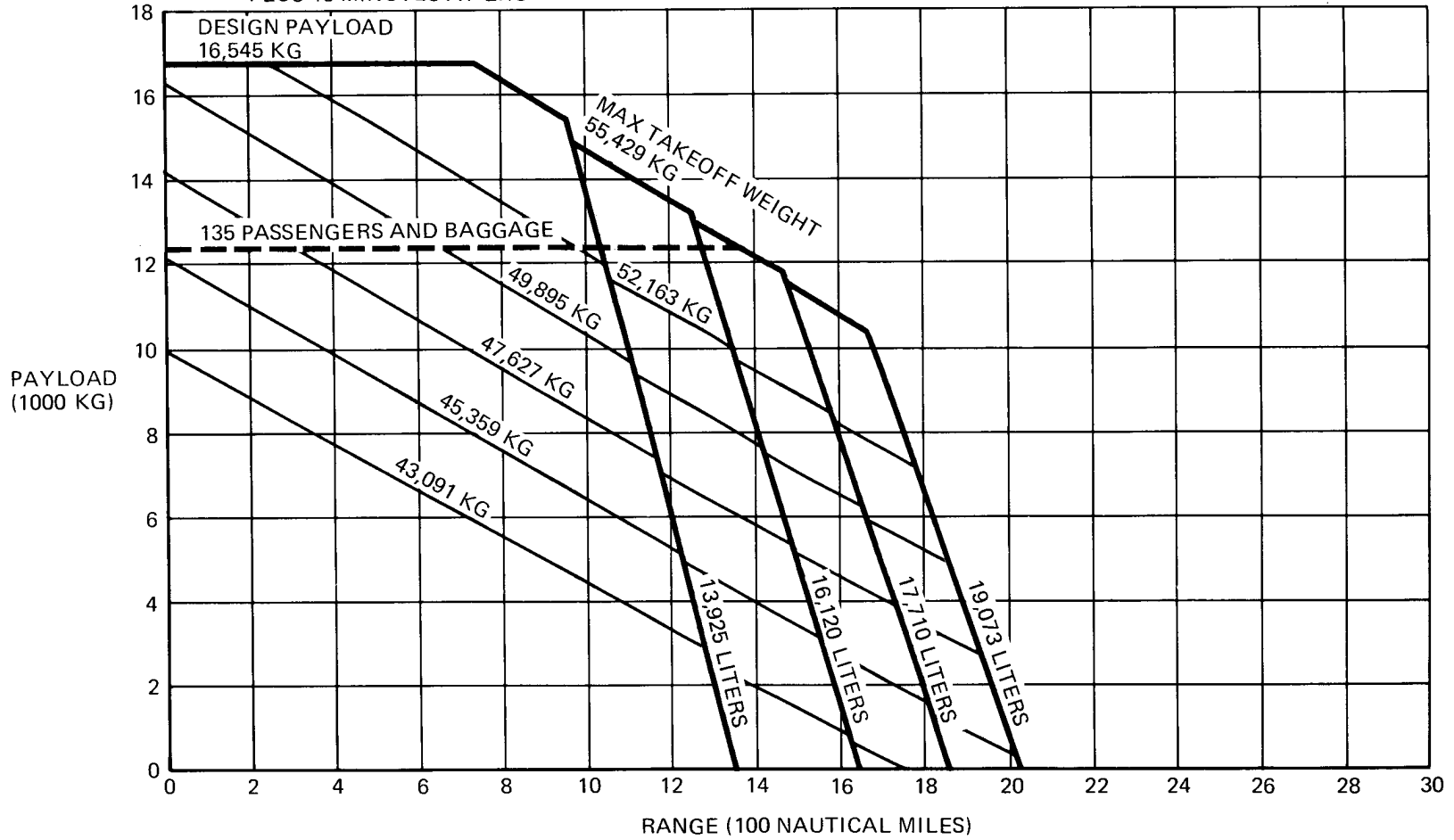

3.2 PAYLOAD-RANGE
PAYLOAD-RANGE FOR TYPICAL LONG-RANGE CRUISE AT 9,150 METERS
MODEL DC-9-51

- NOTES:
- JT8D-1 ENGINES
 - MAX TAKEOFF POWER
 - ZERO RUNWAY GRADIENT
 - ZERO WIND
 - COORDINATE WITH USING AIRLINE FOR SPECIFIC REQUIREMENTS PRIOR TO FACILITY DESIGN

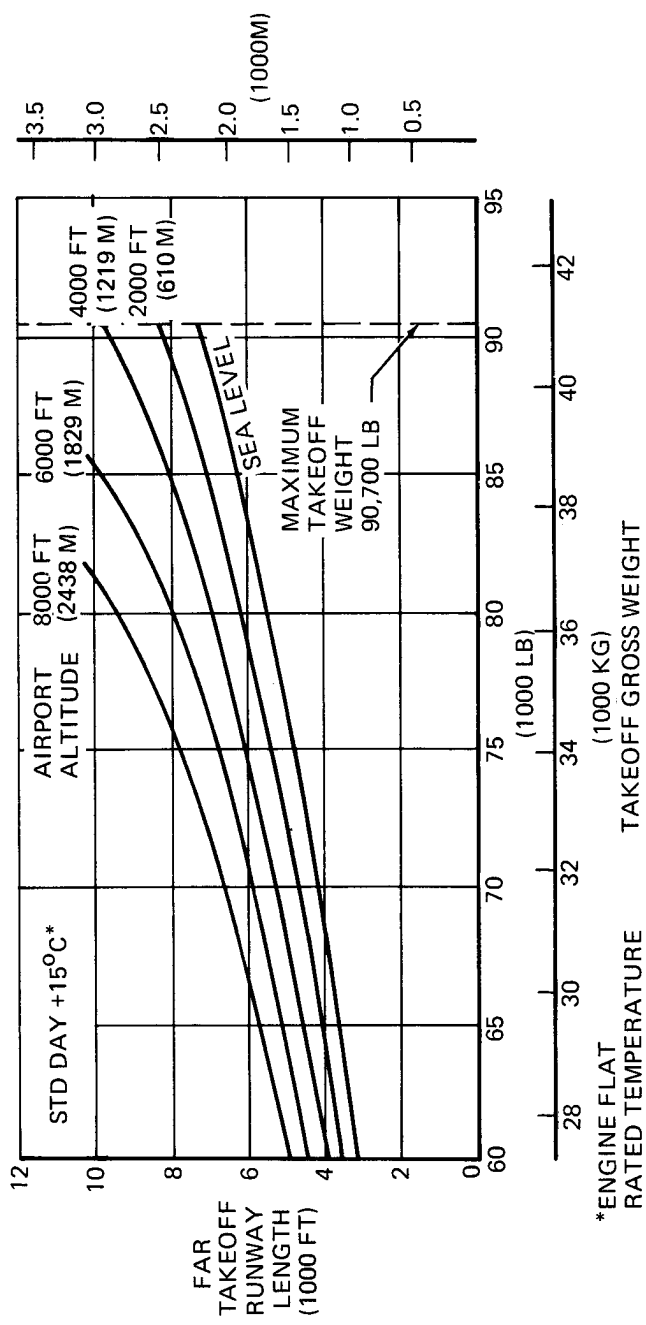

- NOTES:
- JT8D-1 ENGINES
 - MAX TAKEOFF POWER
 - ZERO RUNWAY GRADIENT
 - ZERO WIND
 - COORDINATE WITH USING AIRLINE FOR SPECIFIC REQUIREMENTS PRIOR TO FACILITY DESIGN

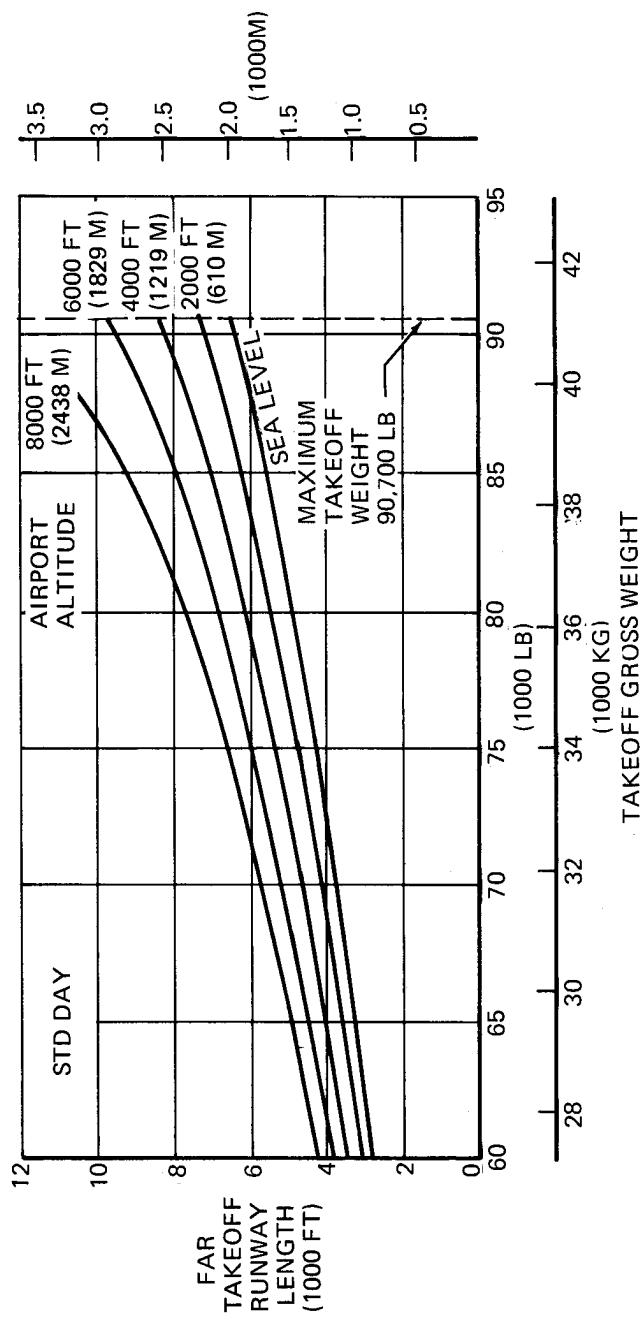

3.3 FAR TAKEOFF RUNWAY LENGTH REQUIREMENTS MODEL DC-9-15

NOTES:

- JT8D-11 ENGINES
- MAX TAKEOFF POWER
- ZERO RUNWAY GRADIENT
- ZERO WIND

- COORDINATE WITH USING AIRLINE FOR SPECIFIC REQUIREMENTS PRIOR TO FACILITY DESIGN

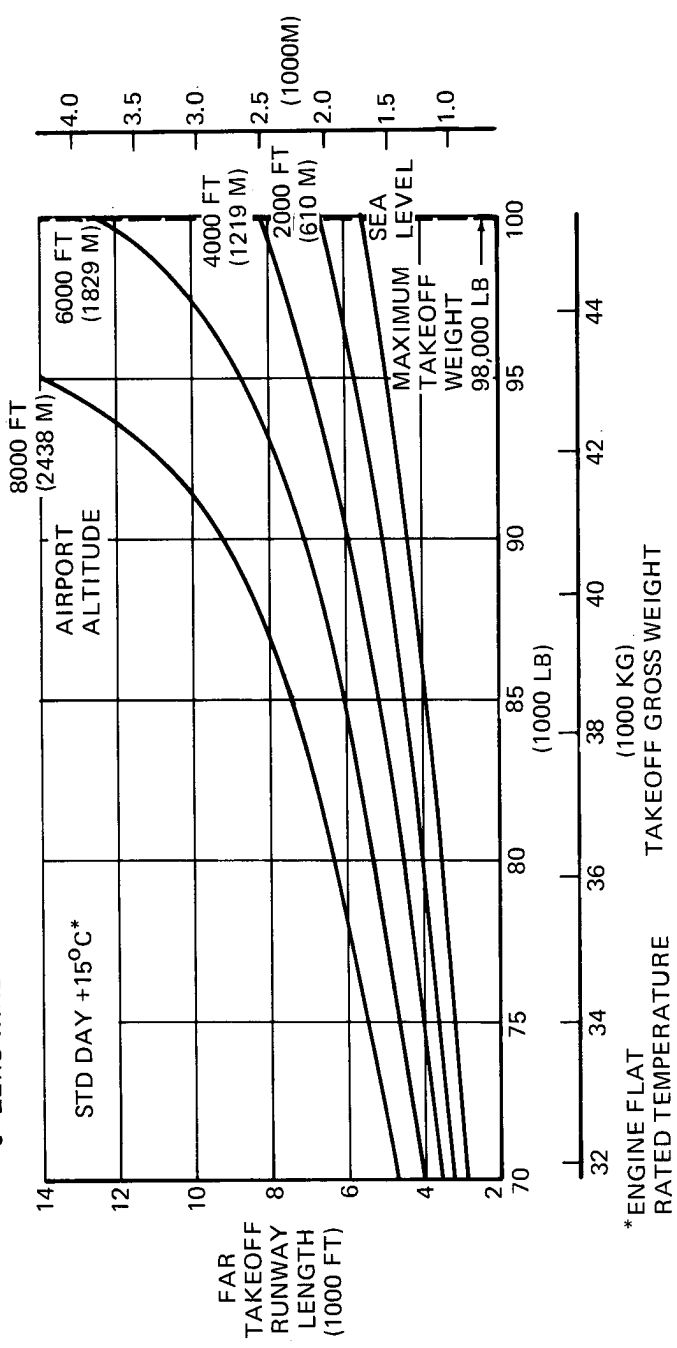

NOTES:

- JT8D-11 ENGINES
- MAX TAKEOFF POWER
- ZERO RUNWAY GRADIENT
- ZERO WIND

- COORDINATE WITH USING AIRLINE FOR SPECIFIC REQUIREMENTS PRIOR TO FACILITY DESIGN

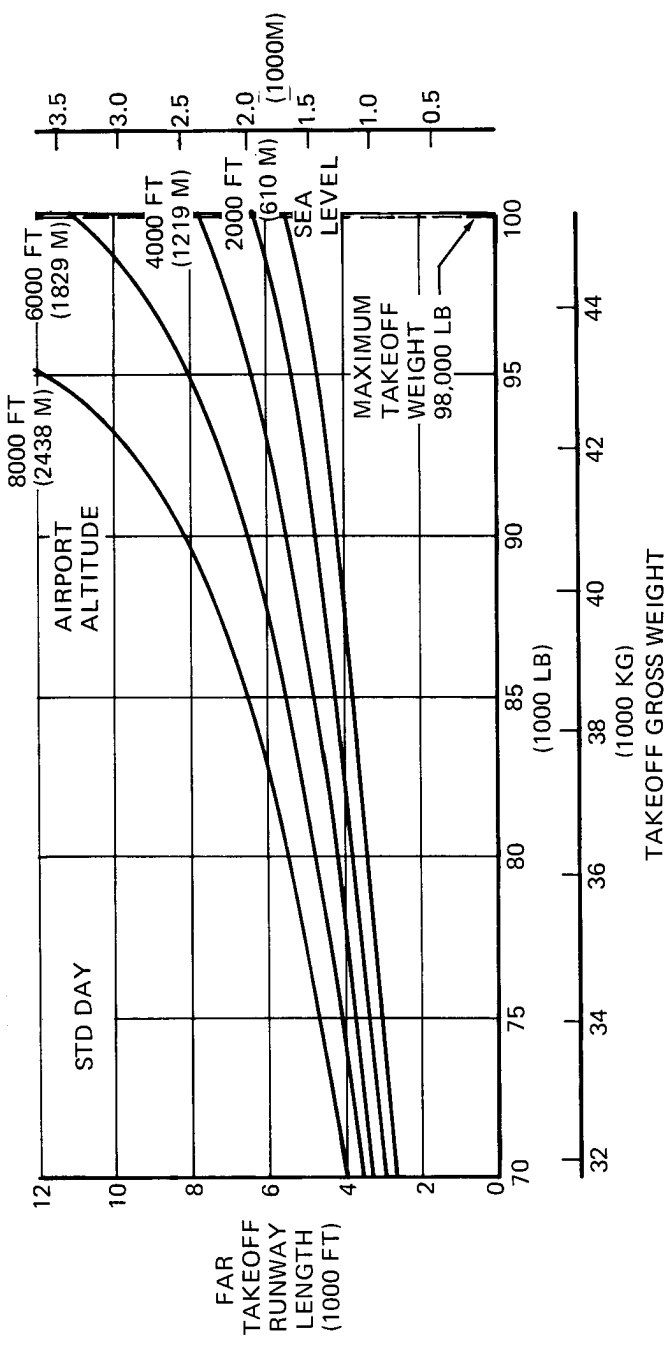

3.3 FAR TAKEOFF RUNWAY LENGTH REQUIREMENTS MODEL DC-9-21

- NOTES:
- JT8D-7 ENGINES
 - MAX TAKEOFF POWER
 - ZERO RUNWAY GRADIENT
 - ZERO WIND
 - COORDINATE WITH USING AIRLINE FOR SPECIFIC REQUIREMENTS PRIOR TO FACILITY DESIGN

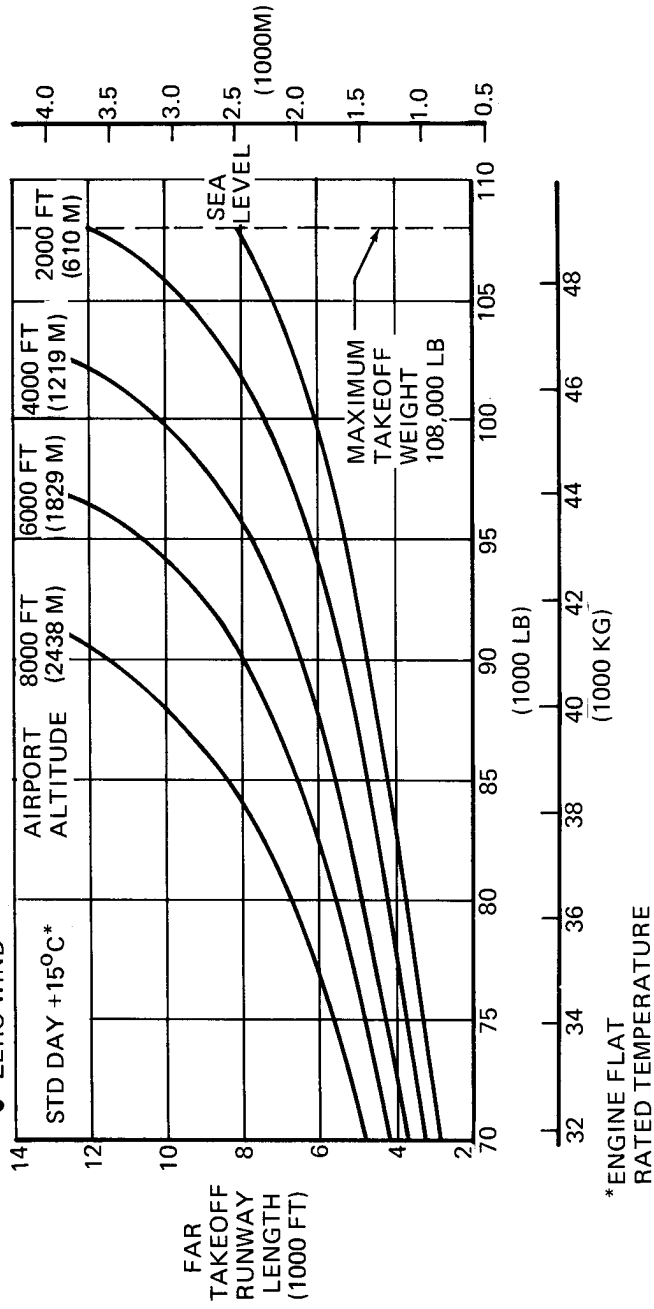

- NOTES:
- JT8D-7 ENGINES
 - MAX TAKEOFF POWER
 - ZERO RUNWAY GRADIENT
 - ZERO WIND
 - COORDINATE WITH USING AIRLINE FOR SPECIFIC REQUIREMENTS PRIOR TO FACILITY DESIGN

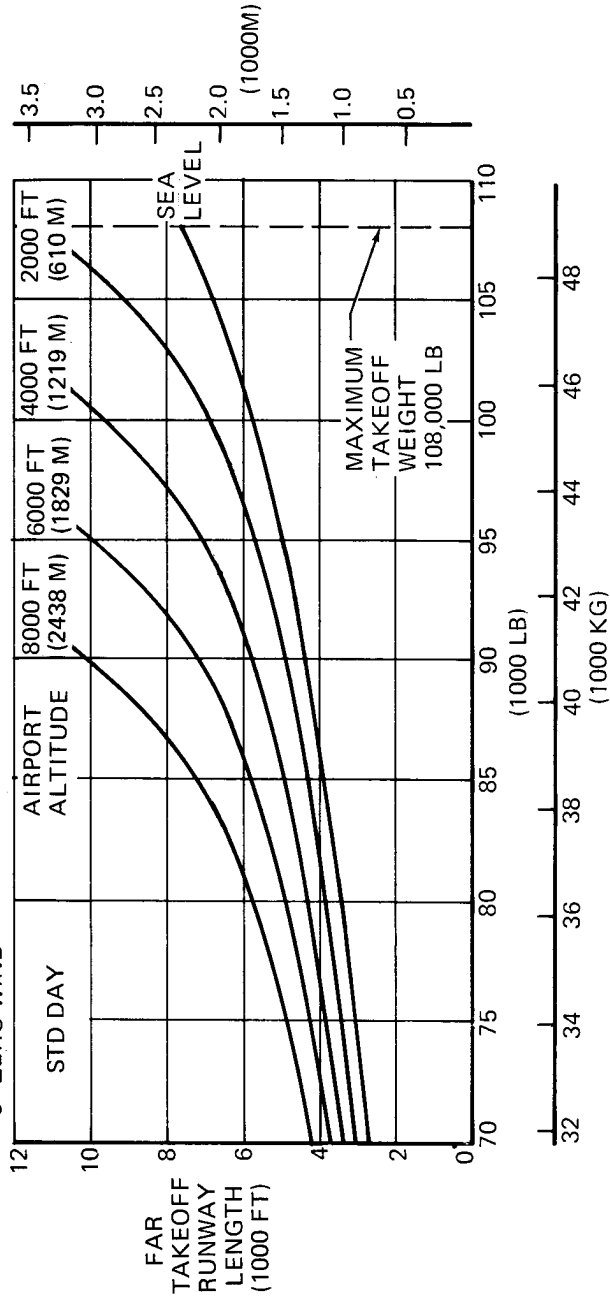

3.3 FAR TAKEOFF RUNWAY LENGTH REQUIREMENTS MODEL DC-9-32

NOTES:

- JT8D-15 ENGINES
- MAX TAKEOFF POWER
- ZERO RUNWAY GRADIENT
- ZERO WIND
- COORDINATE WITH USING AIRLINE FOR SPECIFIC REQUIREMENTS PRIOR TO FACILITY DESIGN

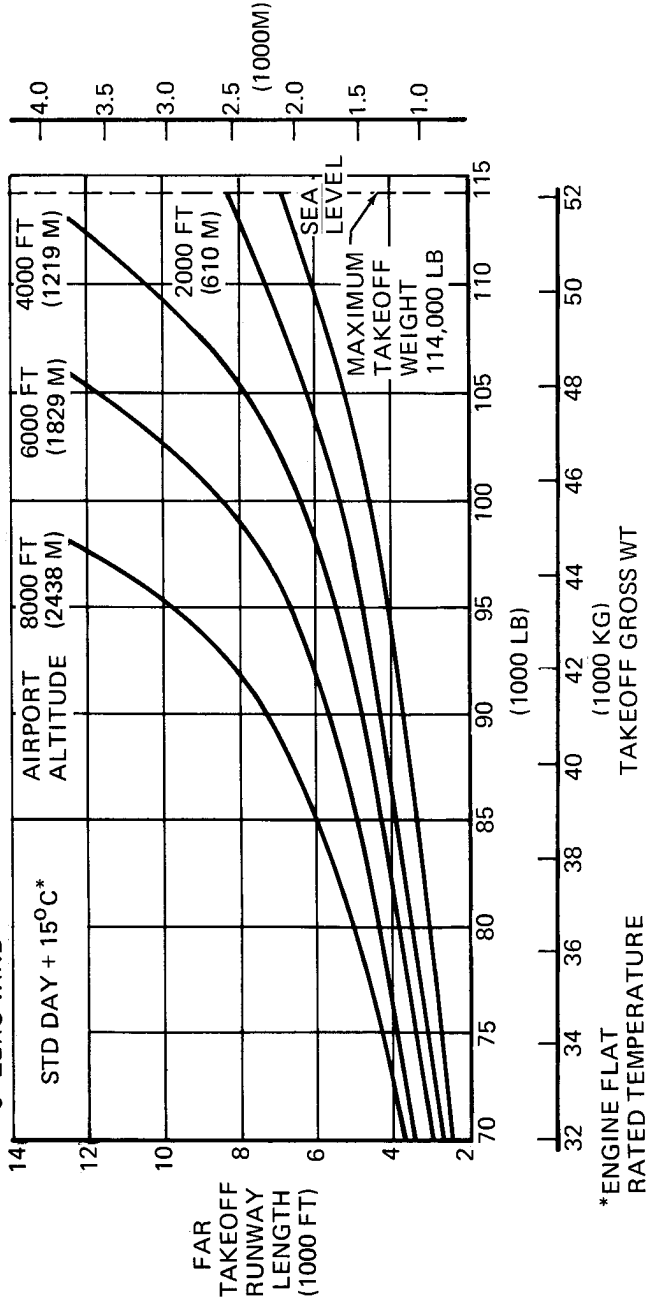

NOTES:

- JT8D-15 ENGINES
- MAX TAKEOFF POWER
- ZERO RUNWAY GRADIENT
- ZERO WIND
- COORDINATE WITH USING AIRLINE FOR SPECIFIC REQUIREMENTS PRIOR TO FACILITY DESIGN

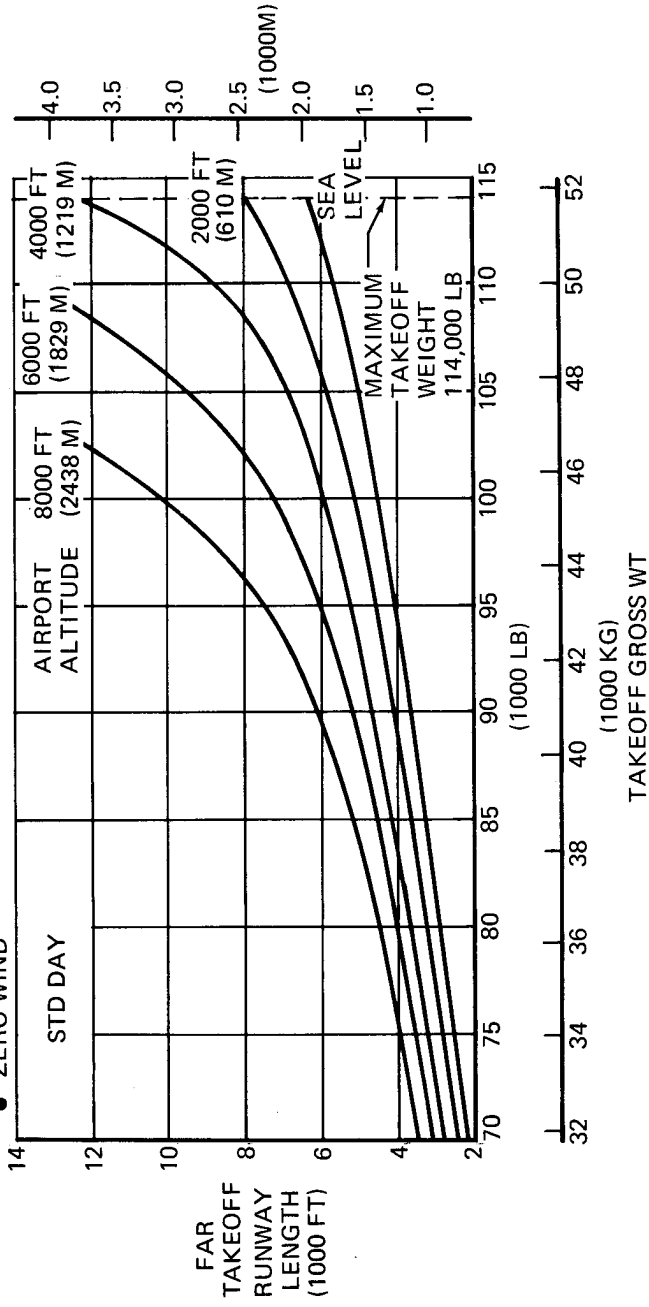

3.3 FAR TAKEOFF RUNWAY LENGTH REQUIREMENTS MODEL DC-9-41

- NOTES:
- JT8D-17 ENGINES
 - MAX TAKEOFF POWER
 - ZERO RUNWAY GRADIENT
 - ZERO WIND
 - COORDINATE WITH USING AIRLINE FOR SPECIFIC REQUIREMENTS PRIOR TO FACILITY DESIGN

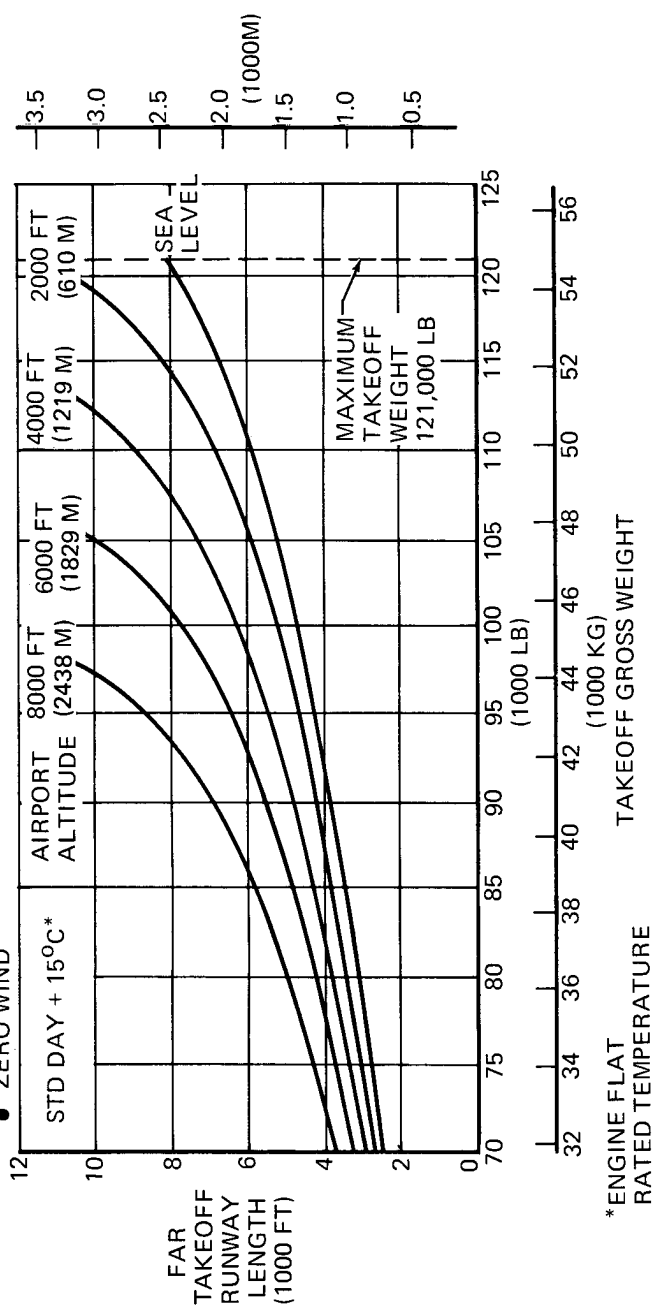

- NOTES:
- JT8D-17 ENGINES
 - MAX TAKEOFF POWER
 - ZERO RUNWAY GRADIENT
 - ZERO WIND
 - COORDINATE WITH USING AIRLINE FOR SPECIFIC REQUIREMENTS PRIOR TO FACILITY DESIGN

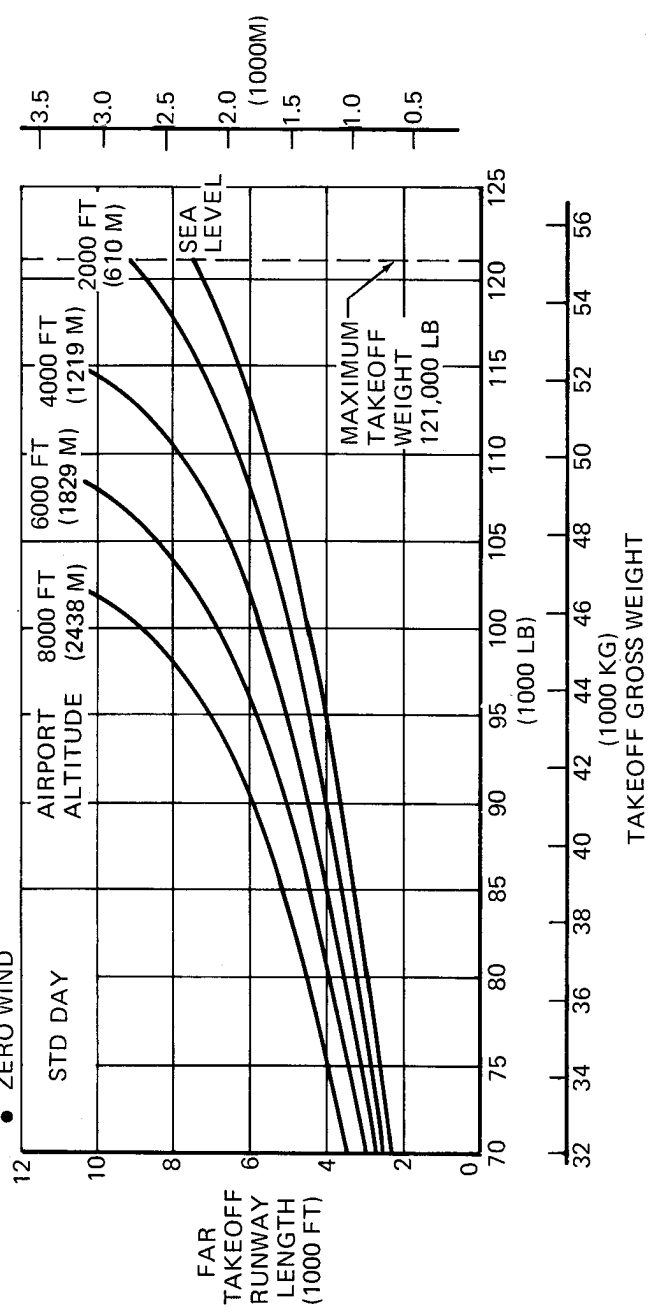

3.3 FAR TAKEOFF RUNWAY LENGTH REQUIREMENTS MODEL DC-9-51

NOTES:

- STANDARD DAY
- 3-DEG GLIDESLOPE
- ZERO WIND AT 50-FOOT HEIGHT
- ZERO RUNWAY GRADIENT
- COORDINATE WITH USING AIRLINES FOR SPECIFIC REQUIREMENTS PRIOR TO FACILITY DESIGN

- $V_{APP} = 1.3 V_S$ FAR
(DRY AND WET RUNWAY)
- V_{APP} IS APPROACH VELOCITY
- V_S IS STALL VELOCITY

LEGEND

- WET RUNWAY
- - - DRY RUNWAY

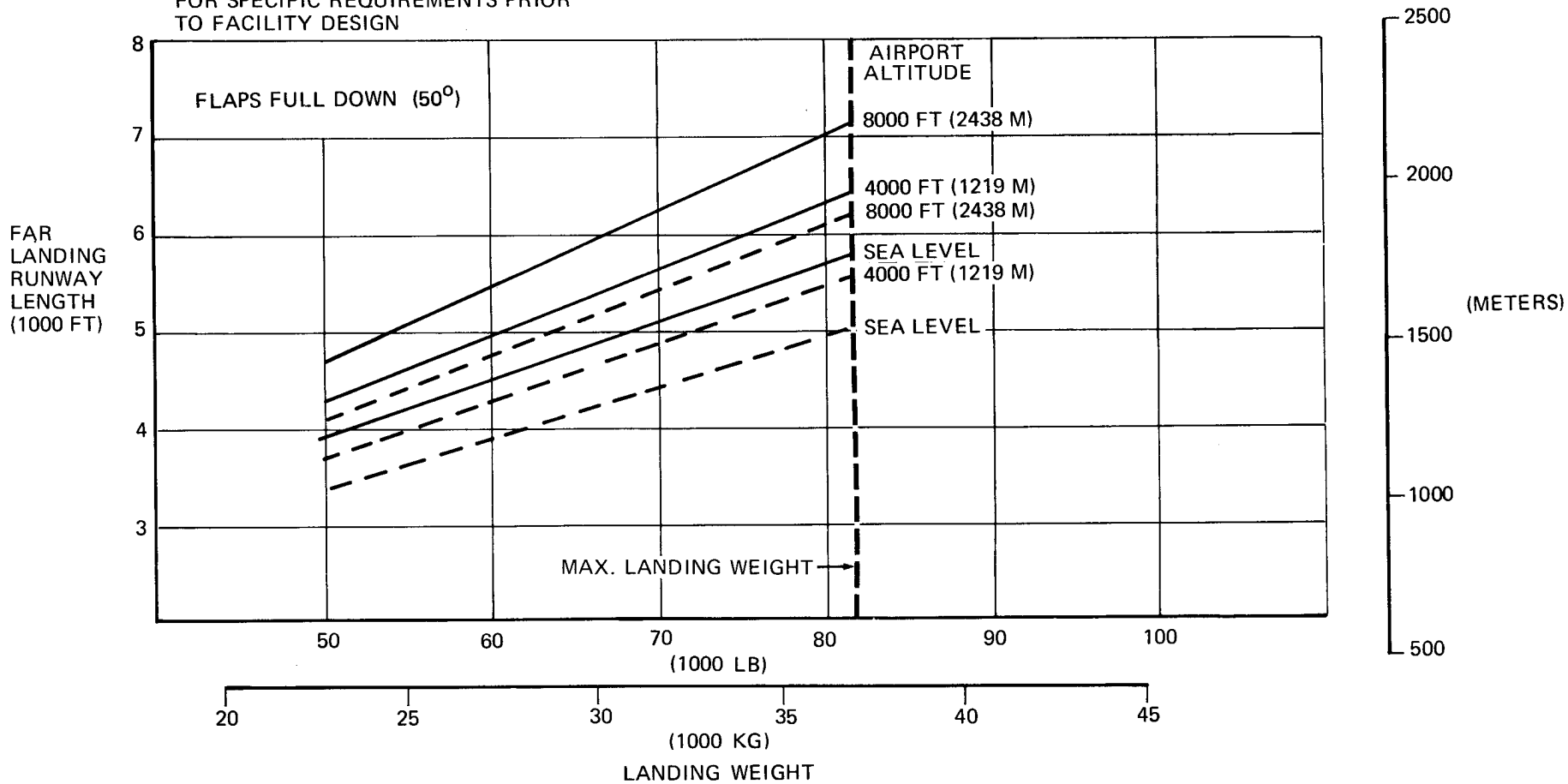

3.4 FAR LANDING RUNWAY LENGTH REQUIREMENTS
MODEL DC-9-15

- STANDARD DAY
- 3-DEG GLIDESLOPE
- ZERO WIND AT 50-FOOT HEIGHT
- ZERO RUNWAY GRADIENT
- COORDINATE WITH USING AIRLINES FOR SPECIFIC REQUIREMENTS PRIOR TO FACILITY DESIGN

• $V_{APP} = 1.3 V_S$ FAR
(DRY AND WET RUNWAY)

V_{APP} IS APPROACH VELOCITY
 V_S IS STALL VELOCITY

LEGEND

— WET RUNWAY
- - - DRY RUNWAY

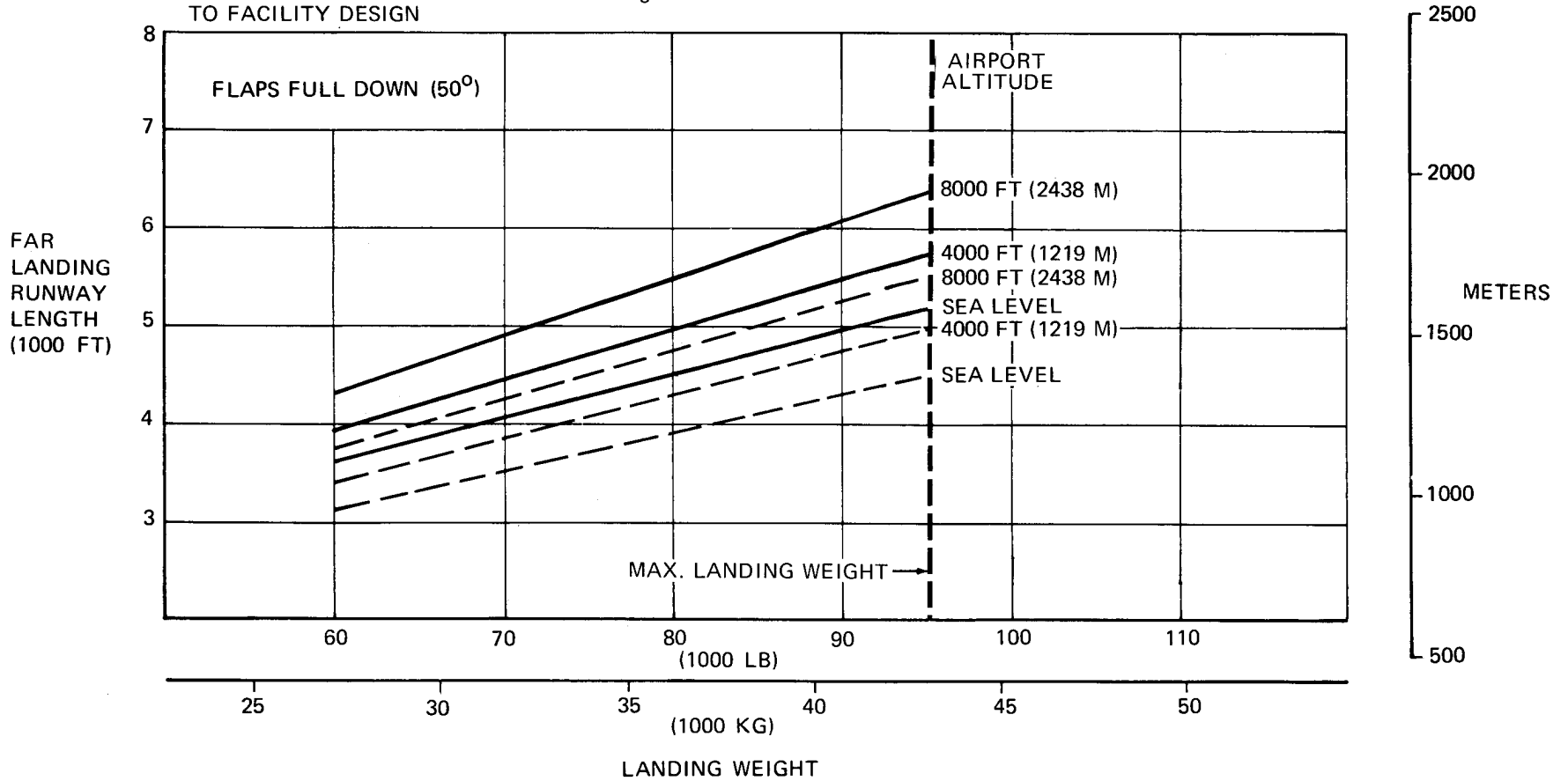

3.4 FAR LANDING RUNWAY LENGTH REQUIREMENTS MODEL DC-9-21

NOTES:

- STANDARD DAY
- 3-DEG GLIDESLOPE
- ZERO WIND AT 50-FOOT HEIGHT
- ZERO RUNWAY GRADIENT
- COORDINATE WITH USING AIRLINES FOR SPECIFIC REQUIREMENTS PRIOR TO FACILITY DESIGN

$V_{APP} = 1.3 V_S$ FAR
(DRY AND WET RUNWAY)

V_{APP} IS APPROACH VELOCITY
 V_S IS STALL VELOCITY

LEGEND

— WET RUNWAY
- - - DRY RUNWAY

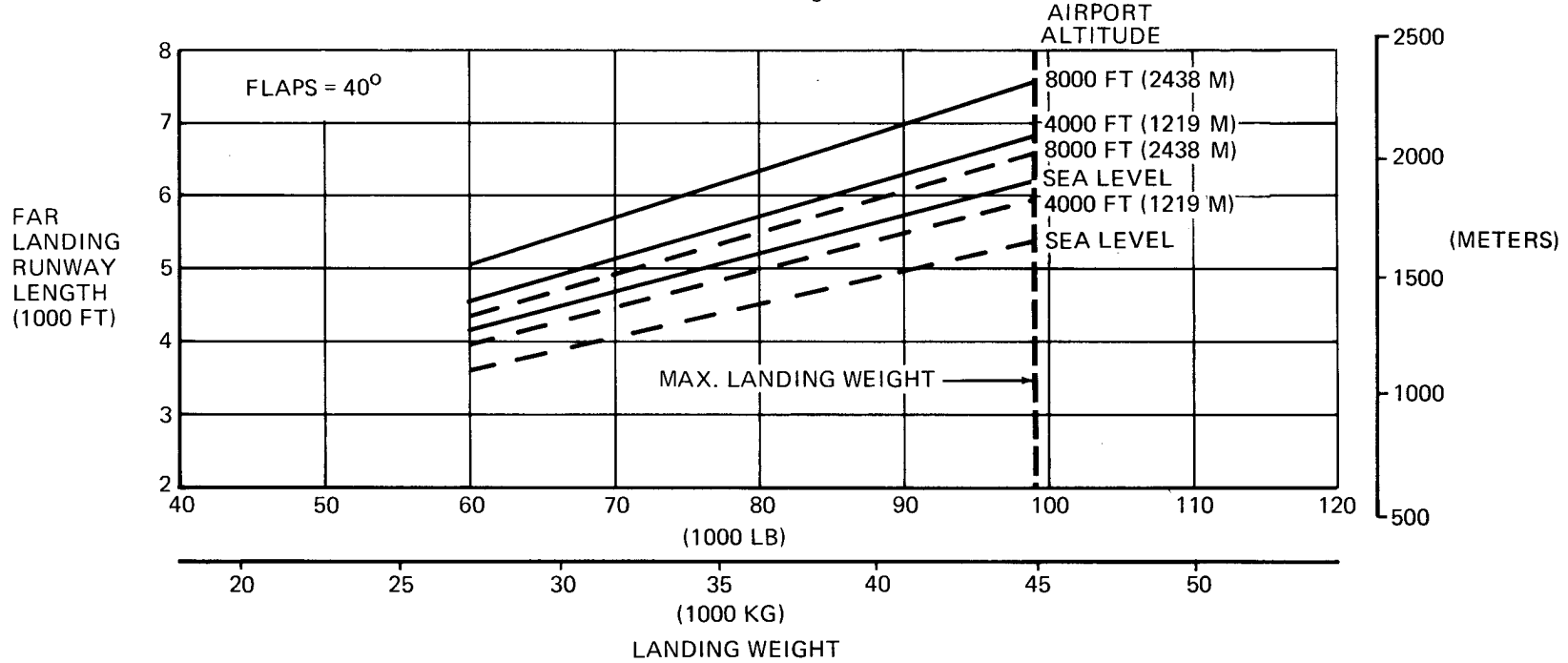

3.4 FAR LANDING RUNWAY LENGTH REQUIREMENTS MODEL DC-9-32

- STANDARD DAY
- 3-DEG GLIDESLOPE
- ZERO WIND AT 50-FOOT HEIGHT
- ZERO RUNWAY GRADIENT
- COORDINATE WITH USING AIRLINES FOR SPECIFIC REQUIREMENTS PRIOR TO FACILITY DESIGN

- $V_{APP} = 1.3 V_S$ FAR (DRY AND WET RUNWAY)
- V_{APP} IS APPROACH VELOCITY
- V_S IS STALL VELOCITY

LEGEND
 ——— WET RUNWAY
 - - - DRY RUNWAY

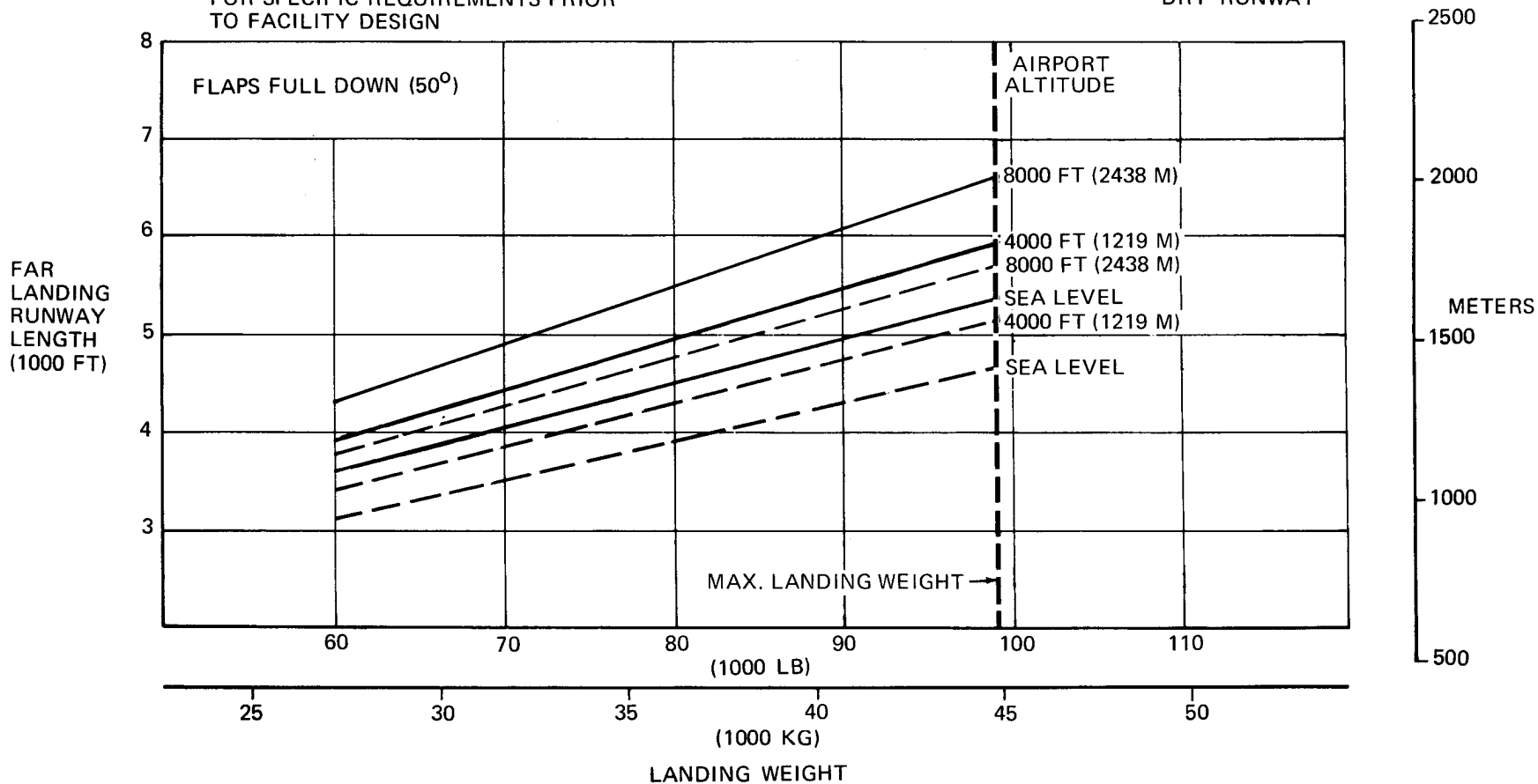

3.4 FAR LANDING RUNWAY LENGTH REQUIREMENTS MODEL DC-9-32

NOTES:

- STANDARD DAY
- 3-DEG GLIDESLOPE
- ZERO WIND AT 50-FOOT HEIGHT
- ZERO RUNWAY GRADIENT
- COORDINATE WITH USING AIRLINES FOR SPECIFIC REQUIREMENTS PRIOR TO FACILITY DESIGN

$V_{APP} = 1.3 V_S$ FAR
(DRY AND WET RUNWAY)

V_{APP} IS APPROACH VELOCITY
 V_S IS STALL VELOCITY

LEGEND

———— WET RUNWAY
- - - - DRY RUNWAY

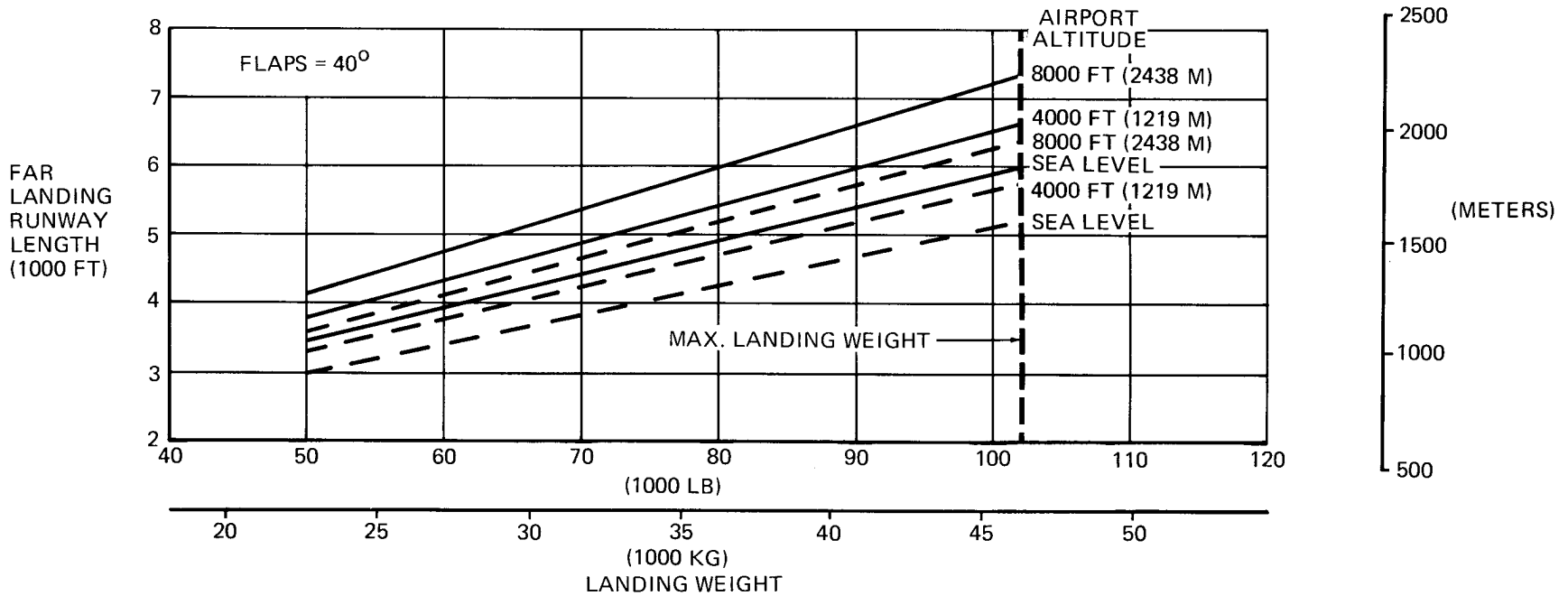

3.4 FAR LANDING RUNWAY LENGTH REQUIREMENTS
MODEL DC-9-41

NOTES:

- STANDARD DAY
 - 3-DEG GLIDESLOPE
 - ZERO WIND AT 50-FOOT HEIGHT
 - ZERO RUNWAY GRADIENT
 - COORDINATE WITH USING AIRLINES FOR SPECIFIC REQUIREMENTS PRIOR TO FACILITY DESIGN
 - $V_{APP} = 1.3 V_S$ FAR (DRY AND WET RUNWAY)
- V_{APP} IS APPROACH VELOCITY
 V_S IS STALL VELOCITY

LEGEND

- WET RUNWAY
- - - DRY RUNWAY

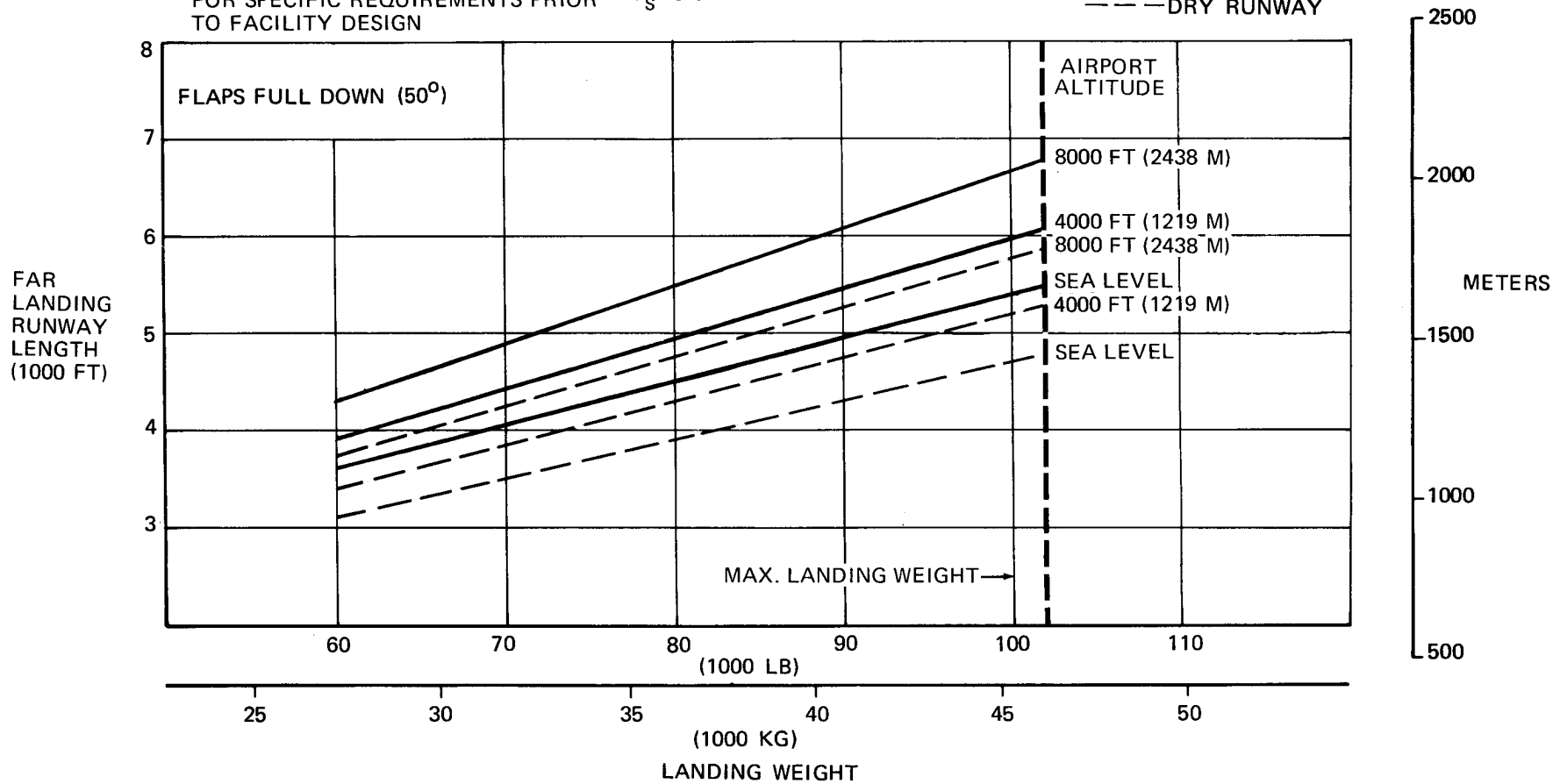

3.4 FAR LANDING RUNWAY LENGTH REQUIREMENTS MODEL DC-9-41

NOTE:

- STANDARD DAY
- 3-DEG GLIDESLOPE
- ZERO WIND AT 50-FOOT HEIGHT
- ZERO RUNWAY GRADIENT
- COORDINATE WITH USING AIRLINES FOR SPECIFIC REQUIREMENTS PRIOR TO FACILITY DESIGN

$V_{APP} = 1.3 V_S$ FAR
(DRY AND WET RUNWAY)

V_{APP} IS APPROACH VELOCITY

V_S IS STALL VELOCITY

LEGEND

- WET RUNWAY
- - - - DRY RUNWAY

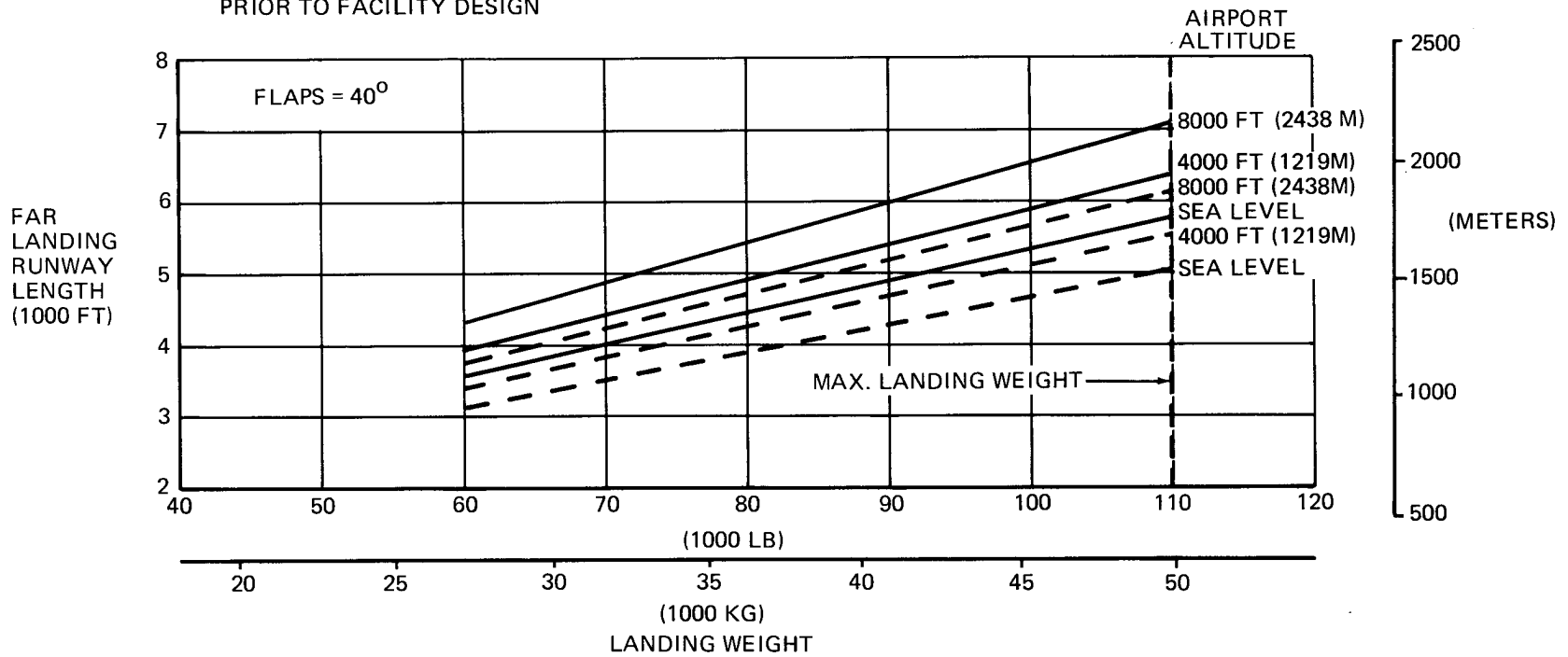

3.4 FAR LANDING RUNWAY LENGTH REQUIREMENTS MODEL DC-9-51

NOTES:

- STANDARD DAY
- 3-DEG GLIDESLOPE
- ZERO WIND AT 50-FOOT HEIGHT
- ZERO RUNWAY GRADIENT
- COORDINATE WITH USING AIRLINES FOR SPECIFIC REQUIREMENTS PRIOR TO FACILITY DESIGN

- $V_{APP} = 1.3 V_S$ FAR (DRY AND WET RUNWAY)
- V_{APP} IS APPROACH VELOCITY
- V_S IS STALL VELOCITY

LEGEND

- WET RUNWAY
- - - DRY RUNWAY

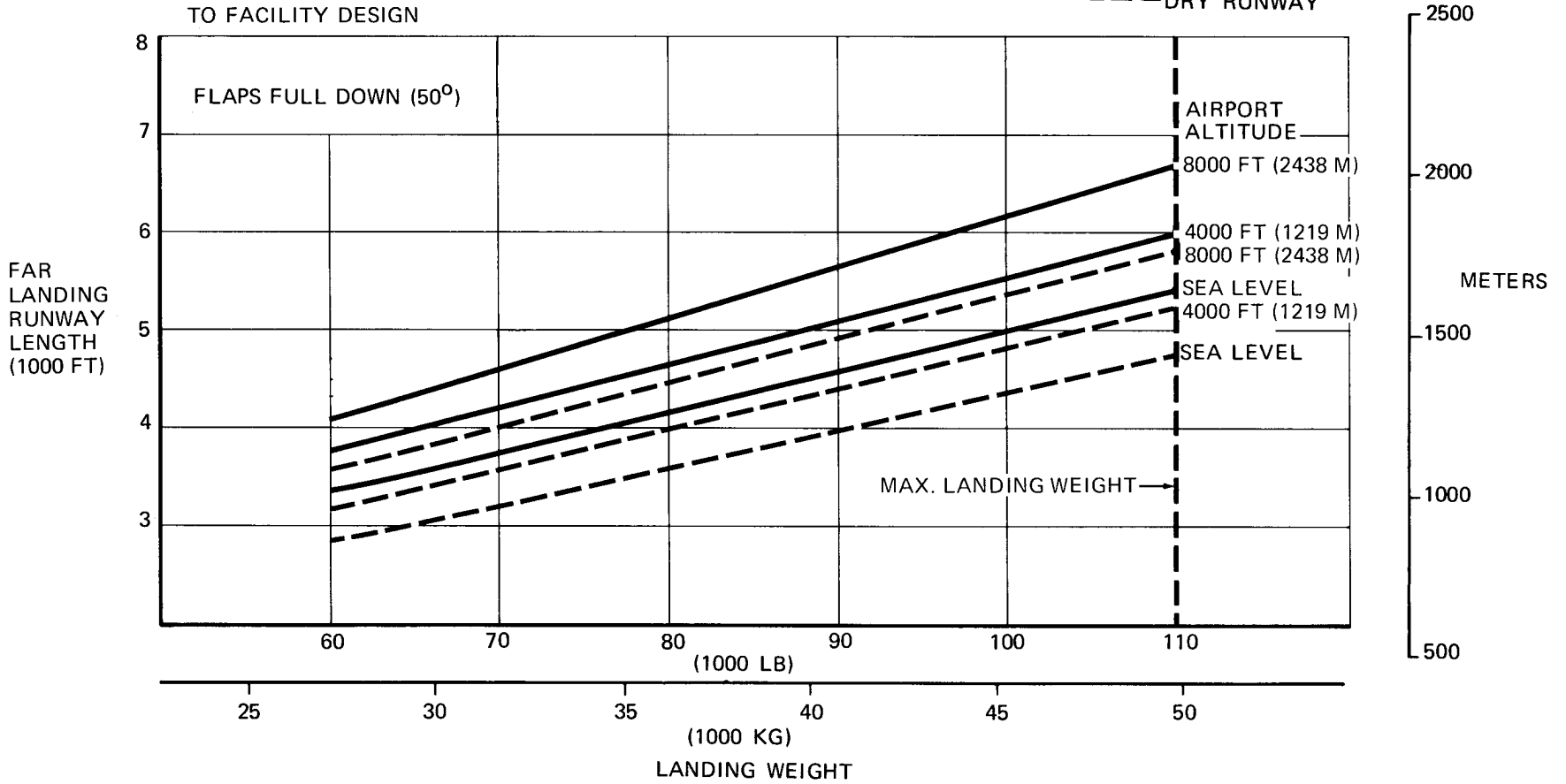

3.4 FAR LANDING RUNWAY LENGTH REQUIREMENTS MODEL DC-9-51

4.0 GROUND MANEUVERING

- 4.1 General Information
- 4.2 Turning Radii, No Slip Angle
- 4.3 Minimum Turning Radii
- 4.4 Runway and Taxiway Turn Paths
- 4.5 Runway Holding Bay (Apron)

4.0 GROUND MANEUVERING

4.1 General Information

This section provides airplane turning capability and maneuvering characteristics.

For ease of presentation, this data has been determined from the theoretical limits imposed by the geometry of the aircraft, and where noted, provides for a normal allowance for tire slippage. As such, it reflects the turning capability of the aircraft in favorable operating circumstances. This data should only be used as guidelines for the method of determination of such parameters and for the maneuvering characteristics of this aircraft type.

In the ground operating mode, varying airline practices may demand that more conservative turning procedures be adopted to avoid excessive tire wear and reduce possible maintenance problems. Airline operating techniques will vary, in the level of performance, over a wide range of operating circumstances throughout the world. Variations from standard aircraft operating patterns may be necessary to satisfy physical constraints within the maneuvering area, such as adverse grades, limited area or high risk of jet blast damage. For these reasons, ground maneuvering requirements should be coordinated with the using airlines prior to layout planning.

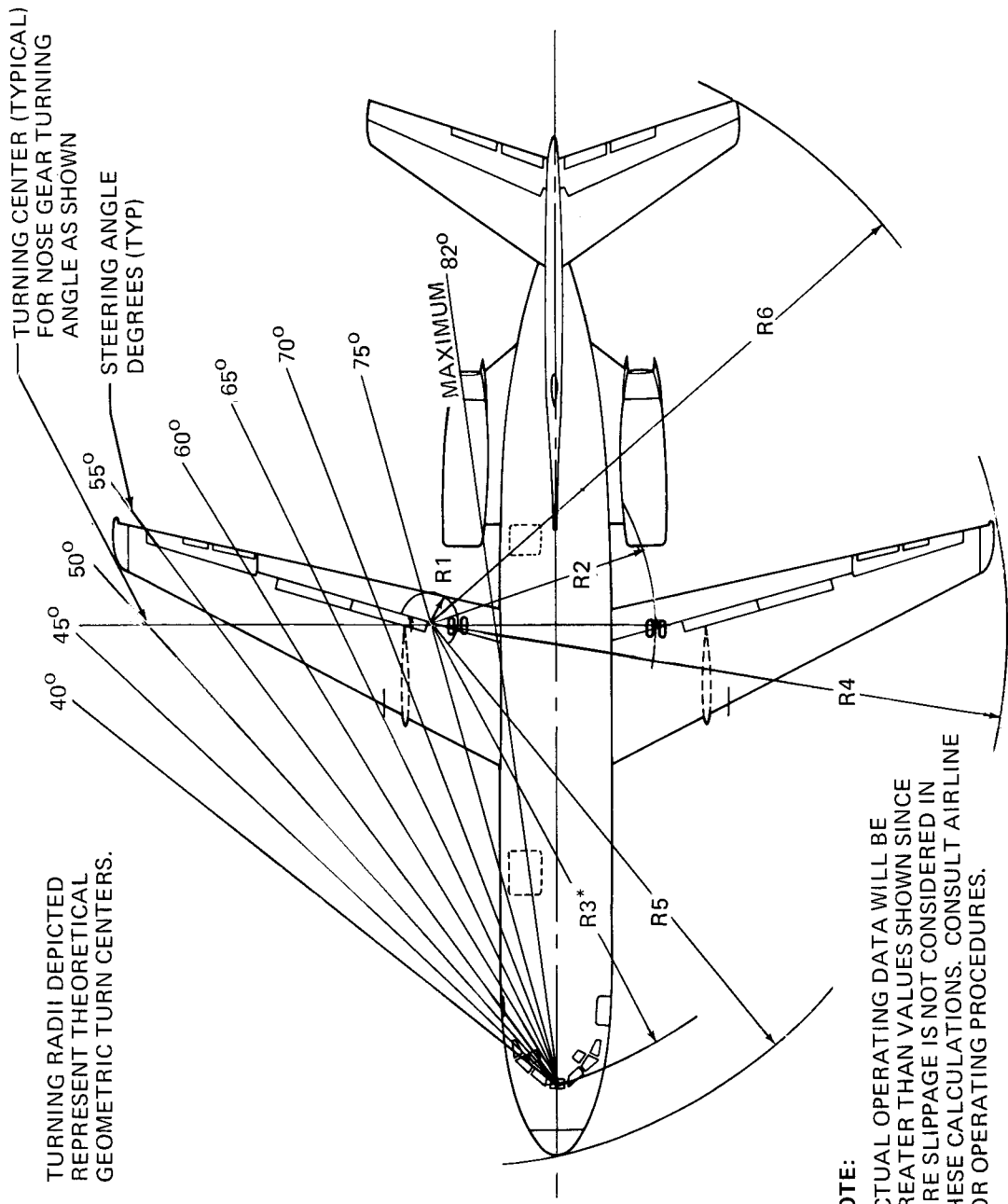

NOTE:

ACTUAL OPERATING DATA WILL BE GREATER THAN VALUES SHOWN SINCE TIRE SLIPPAGE IS NOT CONSIDERED IN THESE CALCULATIONS. CONSULT AIRLINE FOR OPERATING PROCEDURES.

*R-3 IS MEASURED TO OUTSIDE TIRE FACE.

STEERING ANGLE (DEGREES)	R-1		R-2		R-3*		R-4		R-5		R-6	
	FT	M	FT	M	FT	M	FT	M	FT	M	FT	M
30	67.5	20.6	83.8	25.5	88.1	26.9	120.9	36.9	91.4	27.9	108.0	32.9
45	35.5	10.8	51.8	15.8	62.6	19.1	89.2	27.2	67.3	20.5	81.7	24.9
50	28.5	8.7	44.8	13.7	57.8	17.6	82.2	25.1	63.0	19.2	76.5	23.3
55	22.4	6.8	38.7	11.8	54.1	16.5	76.2	23.2	59.7	18.2	72.3	22.0
60	17.0	5.2	33.4	10.2	51.2	15.6	70.9	21.6	57.1	17.4	68.8	21.0
65	12.2	3.7	28.5	8.7	49.0	14.9	66.1	20.1	55.1	16.8	65.8	20.1
70	7.7	2.3	24.1	7.3	47.3	14.4	61.8	18.8	53.7	16.4	63.3	19.3
75	3.5	1.1	19.9	6.1	46.0	14.0	57.7	17.6	52.6	16.0	61.1	18.6
82 MAXIMUM	-2.0	-0.6	14.3	4.4	44.9	13.7	52.2	15.9	51.6	15.7	58.5	17.8

4.2 TURNING RADIUS, NO SLIP ANGLE MODEL DC-9-15

TURNING RADII DEPICTED REPRESENT THEORETICAL GEOMETRIC TURN CENTERS.

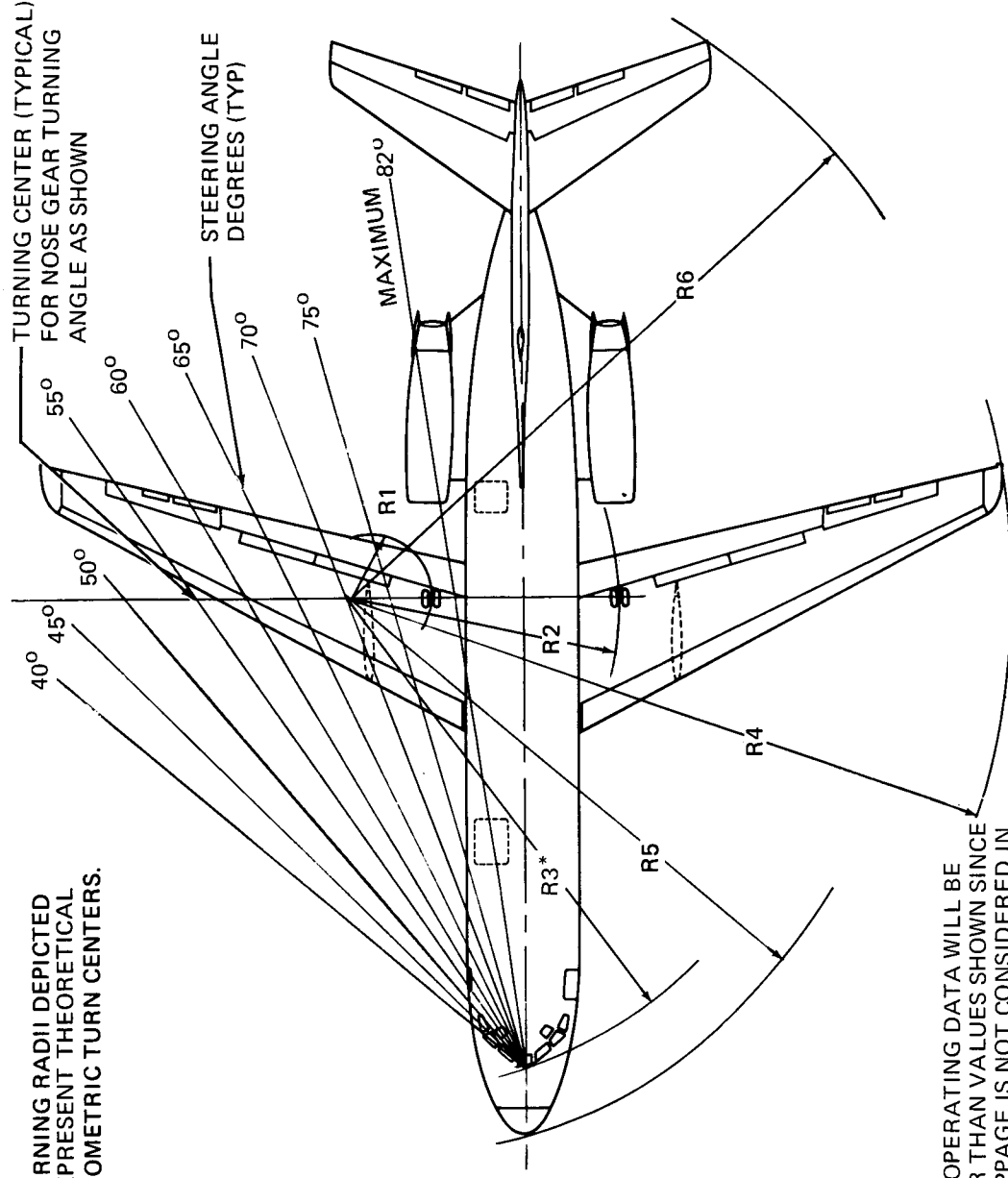

NOTE:
 ACTUAL OPERATING DATA WILL BE GREATER THAN VALUES SHOWN SINCE TIRE SLIPPAGE IS NOT CONSIDERED IN THESE CALCULATIONS. CONSULT AIRLINE FOR OPERATING PROCEDURES

* R-3 IS MEASURED TO OUTSIDE TIRE FACE

STEERING ANGLE (DEGREES)	R-1		R-2		R-3*		R-4		R-5		R-6	
	FT	M	FT	M	FT	M	FT	M	FT	M	FT	M
30	67.5	20.6	83.8	25.5	88.1	26.9	122.9	37.5	91.4	27.9	108.0	32.9
45	35.5	10.8	51.8	15.8	62.6	19.1	91.2	27.8	67.3	20.5	81.7	24.9
50	28.5	8.7	44.8	13.7	57.8	17.6	84.2	25.7	63.0	19.2	76.5	23.3
55	22.4	6.8	38.8	11.8	54.1	16.5	78.2	23.8	59.7	18.2	72.3	22.0
60	17.0	5.2	33.4	10.2	51.2	15.6	72.9	22.2	57.1	17.4	68.7	20.9
65	12.2	3.7	28.5	8.7	49.0	14.9	68.2	20.8	55.1	16.8	65.8	20.1
70	7.7	2.3	24.1	7.3	47.3	14.4	63.8	19.4	53.7	16.4	63.2	19.3
75	3.5	1.1	19.9	6.1	46.0	14.0	59.7	18.2	52.6	16.0	61.1	18.6
82 MAXIMUM	-2.0	-0.6	14.3	4.4	44.9	13.7	54.2	16.5	51.6	15.7	58.5	17.8

4.2 TURNING RADII, NO SLIP ANGLE MODEL DC-9-21

TURNING RADII DEPICTED REPRESENT THEORETICAL GEOMETRIC TURN CENTERS.

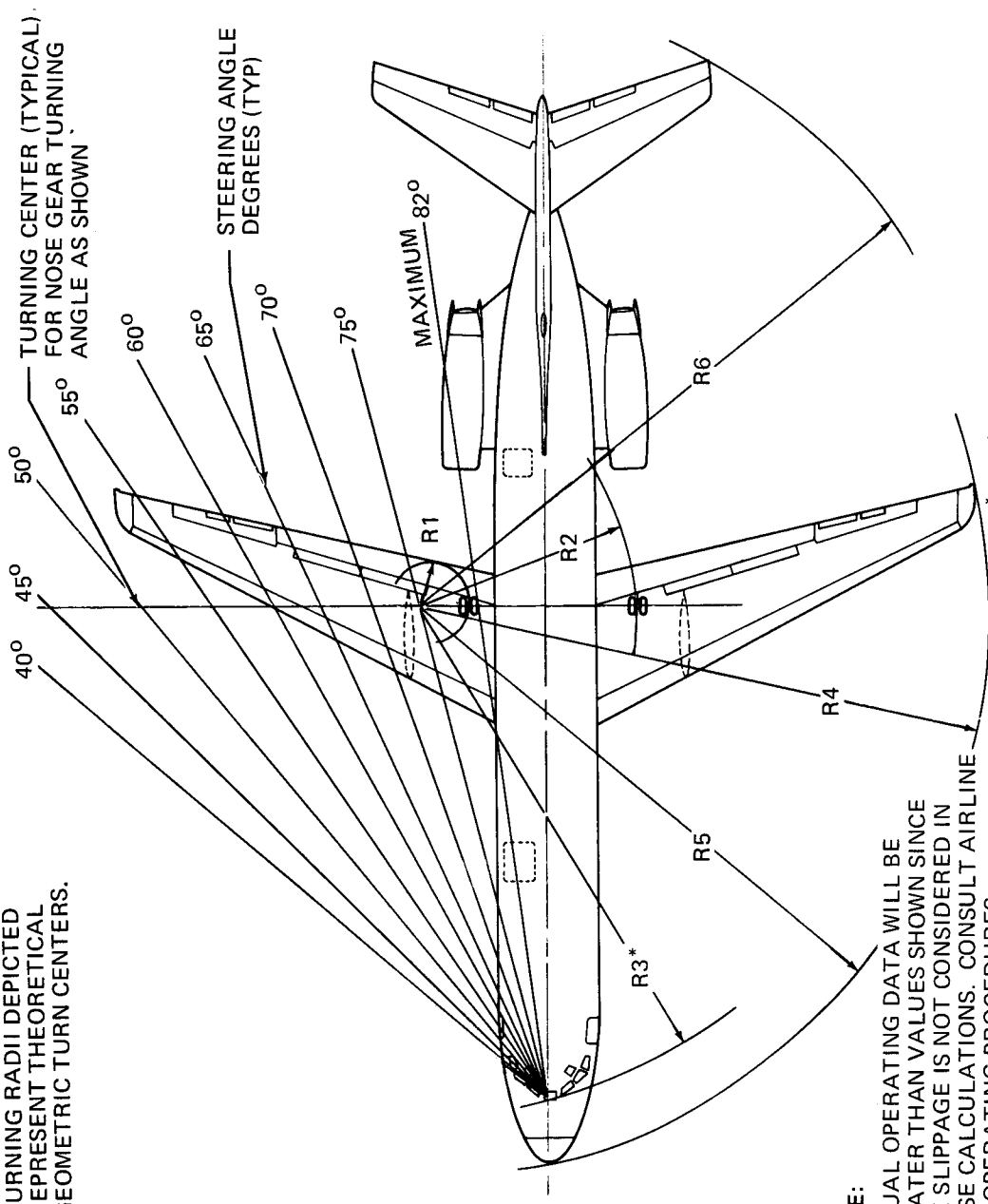

NOTE:

ACTUAL OPERATING DATA WILL BE GREATER THAN VALUES SHOWN SINCE TIRE SLIPPAGE IS NOT CONSIDERED IN THESE CALCULATIONS. CONSULT AIRLINE FOR OPERATING PROCEDURES.

*R-3 IS MEASURED TO OUTSIDE TIRE FACE

STEERING ANGLE (DEGREES)	R-1		R-2		R-3*		R-4		R-5		R-6	
	FT	M	FT	M	FT	M	FT	M	FT	M	FT	M
30	83.9	25.6	100.3	30.6	107.1	32.6	139.3	42.5	110.3	33.6	125.0	38.1
45	45.0	13.7	61.3	18.7	76.0	23.1	100.6	30.7	80.7	24.6	92.5	28.2
50	36.4	11.1	52.8	16.1	70.2	21.4	92.1	28.1	75.4	23.0	86.0	26.2
55	29.1	8.9	45.4	13.8	65.7	20.0	84.8	25.8	71.2	21.7	80.8	24.6
60	22.5	6.9	38.9	11.9	62.2	19.0	78.3	23.9	68.1	20.8	76.4	23.3
65	16.6	5.1	33.0	10.1	59.5	18.1	72.5	22.1	65.6	20.0	72.8	22.2
70	11.2	3.4	27.5	8.4	57.4	17.5	67.2	20.5	63.8	19.4	69.7	21.2
75	6.1	1.9	22.4	6.8	55.8	17.0	62.2	19.0	62.4	19.0	67.0	20.4
82 MAXIMUM	-0.7	-0.2	15.6	4.8	54.5	16.6	55.5	16.9	61.2	18.7	64.0	19.5

4.2 TURNING RADII, NO SLIP ANGLE MODEL DC-9-32

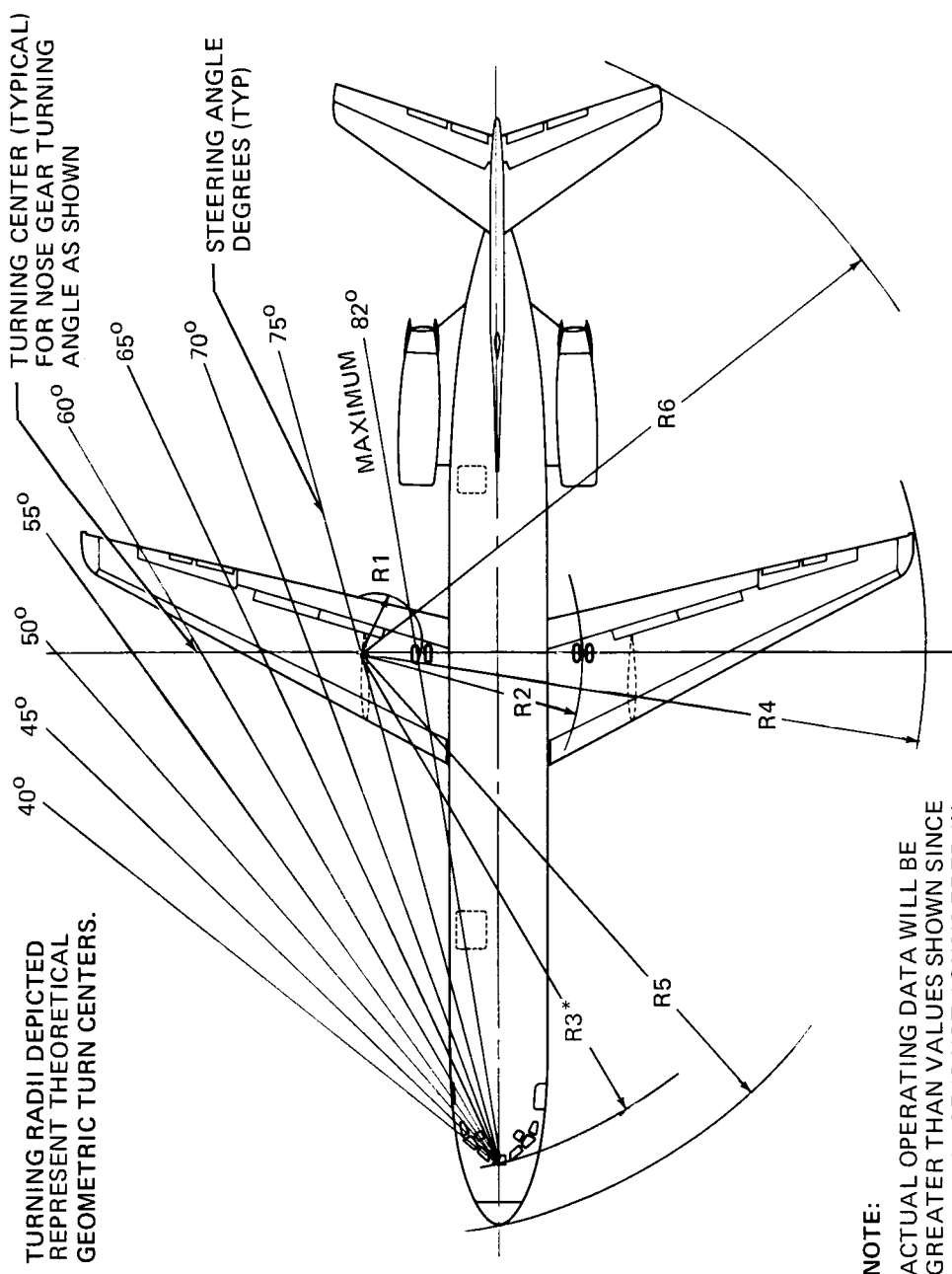

NOTE:
 ACTUAL OPERATING DATA WILL BE GREATER THAN VALUES SHOWN SINCE TIRE SLIPPAGE IS NOT CONSIDERED IN THESE CALCULATIONS. CONSULT AIRLINE FOR OPERATING PROCEDURES.

*R-3 IS MEASURED TO OUTSIDE TIRE FACE

STEERING ANGLE (DEGREES)	R-1		R-2		R-3*		R-4		R-5		R-6	
	FT	M	FT	M	FT	M	FT	M	FT	M	FT	M
30	89.3	27.2	105.3	32.1	113.2	34.5	144.5	44.0	116.4	35.5	131.2	40.0
45	48.2	14.7	64.2	19.6	80.3	24.5	103.6	31.6	85.0	25.9	96.9	29.5
50	39.1	11.9	55.2	16.8	74.2	22.6	94.6	28.8	79.3	24.2	90.1	27.5
55	31.3	9.5	47.4	14.4	69.4	21.2	86.9	26.5	74.9	22.8	84.6	25.8
60	24.4	7.4	40.4	12.3	65.7	20.0	80.1	24.4	71.6	21.8	80.1	24.4
65	18.2	5.5	34.2	10.4	62.8	19.1	73.9	22.5	68.9	21.0	76.3	23.3
70	12.4	3.8	28.5	8.7	60.6	18.5	68.3	20.8	67.0	20.4	73.0	22.3
75	7.1	2.2	23.1	7.0	59.0	18.0	63.0	19.2	65.5	20.0	70.3	21.4
82 MAXIMUM	-0.1	-0.03	15.9	4.8	57.5	17.5	56.0	17.1	64.3	19.6	67.2	20.5

4.2 TURNING RADI II, NO SLIP ANGLE MODEL DC-9-41

TURNING RADIUS DEPICTED REPRESENT THEORETICAL GEOMETRIC TURN CENTERS.

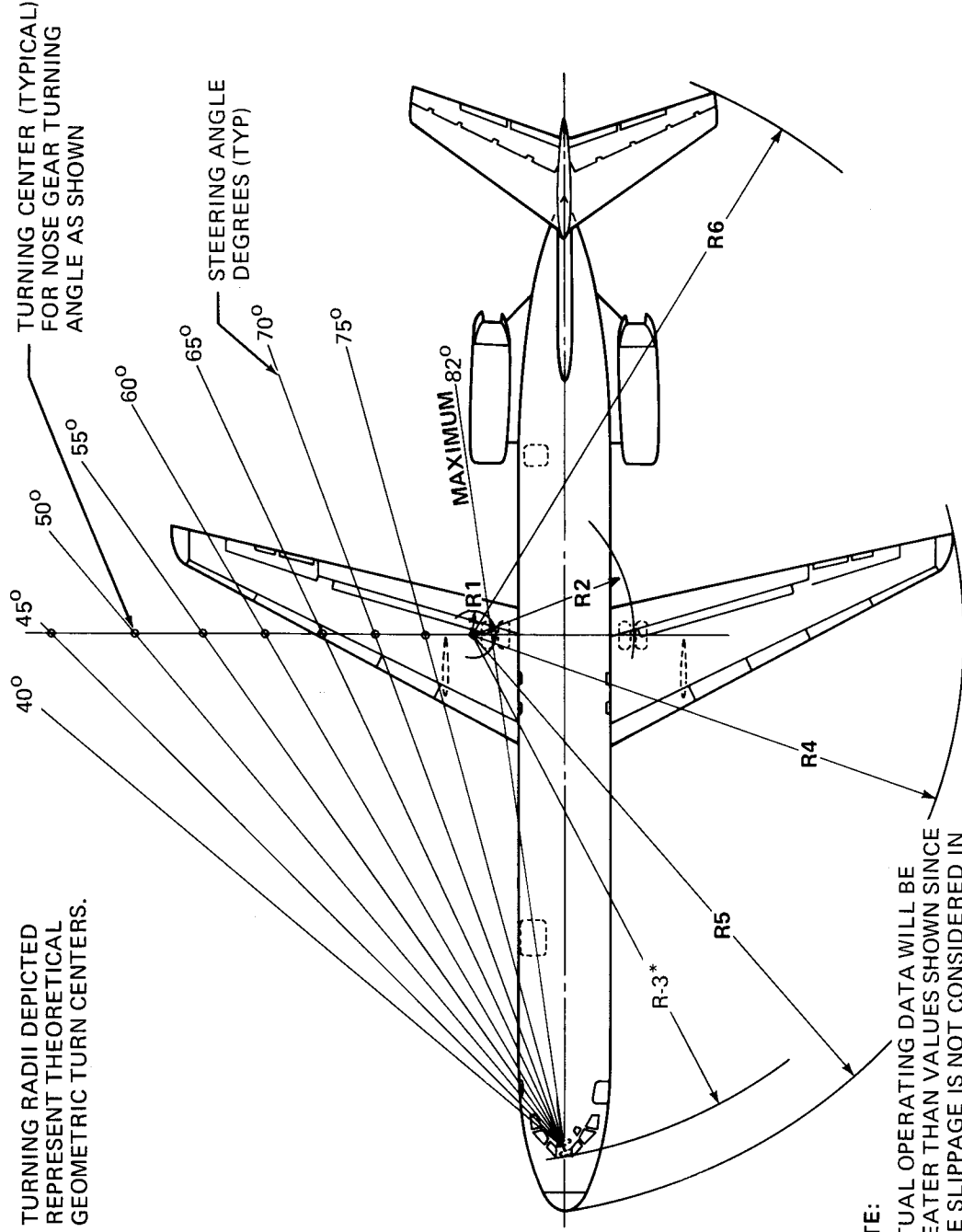

NOTE:

ACTUAL OPERATING DATA WILL BE GREATER THAN VALUES SHOWN SINCE TIRE SLIPPAGE IS NOT CONSIDERED IN THESE CALCULATIONS. CONSULT AIRLINE FOR OPERATING PROCEDURES.

*R-3 IS MEASURED TO OUTSIDE TIRE FACE

STEERING ANGLE (DEGREES)	R-1		R-2		R-3*		R-4		R-5		R-6	
	FT	M	FT	M	FT	M	FT	M	FT	M	FT	M
30	97.5	29.7	113.5	34.6	122.7	37.4	153.8	46.9	125.8	38.3	140.0	42.7
45	52.9	16.1	68.9	21.0	87.0	26.5	109.9	33.5	91.6	27.9	102.6	31.3
50	43.1	13.1	59.1	18.0	80.4	24.5	100.3	30.6	85.4	26.0	95.3	29.0
55	34.6	10.5	50.6	15.4	75.2	22.9	92.1	28.1	80.7	24.6	89.3	27.2
60	27.2	8.3	43.2	13.2	71.2	21.7	84.8	25.8	77.0	23.5	84.3	25.7
65	20.4	6.2	36.4	11.1	68.1	20.8	78.3	23.9	74.1	22.6	80.2	24.4
70	14.2	4.3	30.2	9.2	65.7	20.0	72.4	22.1	72.0	21.9	76.7	23.4
75	8.3	2.5	24.3	7.4	63.9	19.5	66.9	20.4	70.4	21.5	73.8	22.5
82 MAXIMUM	0.6	0.2	16.6	5.1	62.4	19.0	59.6	18.2	69.0	21.0	70.5	21.5

4.2 TURNING RADIUS, NO SLIP ANGLE MODEL DC-9-51

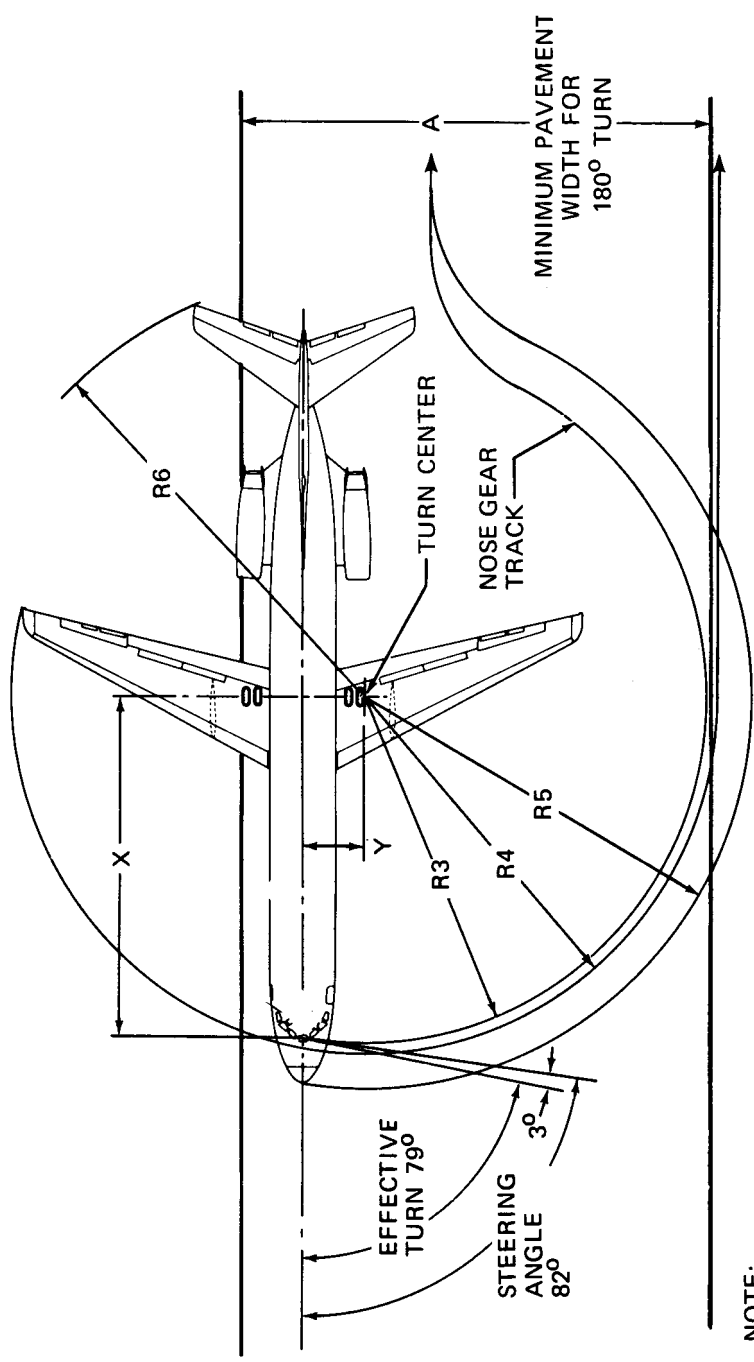

NOTE:

- 3° TIRE SLIP ANGLE ASSUMES 82° NOSE WHEEL DEFLECTION DURING VERY SLOW TURNING
- CONSULT AIRLINE FOR ACTUAL OPERATING DATA
- NO DIFFERENTIAL BRAKING OR UNSYMMETRICAL THRUST

DC-9	EFFECTIVE TURN ANGLE	X		Y		A		R3		R4		R5		R6	
		FT	M	FT	M	FT	M	FT	M	FT	M	FT	M		
-15	79°	43.7	13.3	8.5	2.6	63.7	19.4	45.4	13.8	54.5	16.6	51.9	15.8	59.6	18.2
-21	79°	43.7	13.3	8.5	2.6	63.7	19.4	45.4	13.8	56.5	17.2	51.9	15.8	59.5	18.1
-32	79°	53.2	16.2	10.3	3.1	75.2	22.9	55.1	16.8	58.3	17.8	61.6	18.8	65.2	19.9
-41	79°	56.2	17.1	10.9	3.3	78.9	24.0	58.2	17.7	58.9	18.0	64.7	19.7	68.5	20.9
-51	79°	60.9	18.6	11.8	3.6	84.5	25.8	62.0	18.9	59.8	18.2	69.5	21.2	71.8	21.9
-80	79°	72.4	22.1	14.0	4.3	98.8	30.1	73.6	22.4	69.6	21.2	81.2	24.7	75.9	23.1

4.3 MINIMUM TURNING RADII MODEL DC-9

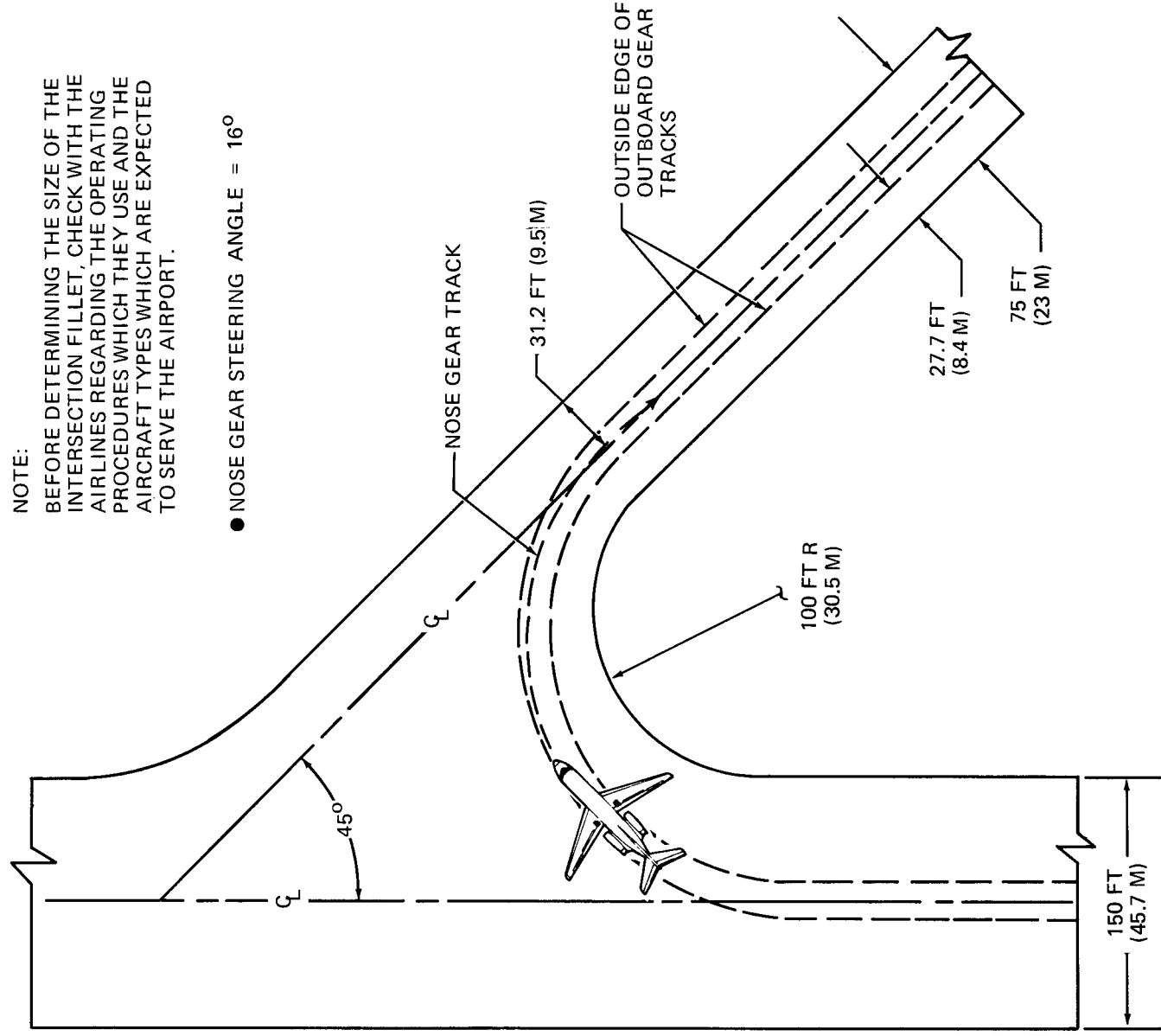

4.4 RUNWAY AND TAXIWAY TURN PATHS

4.4.1 MORE THAN 90° TURN – RUNWAY TO TAXIWAY TURN

MODEL DC-9-15

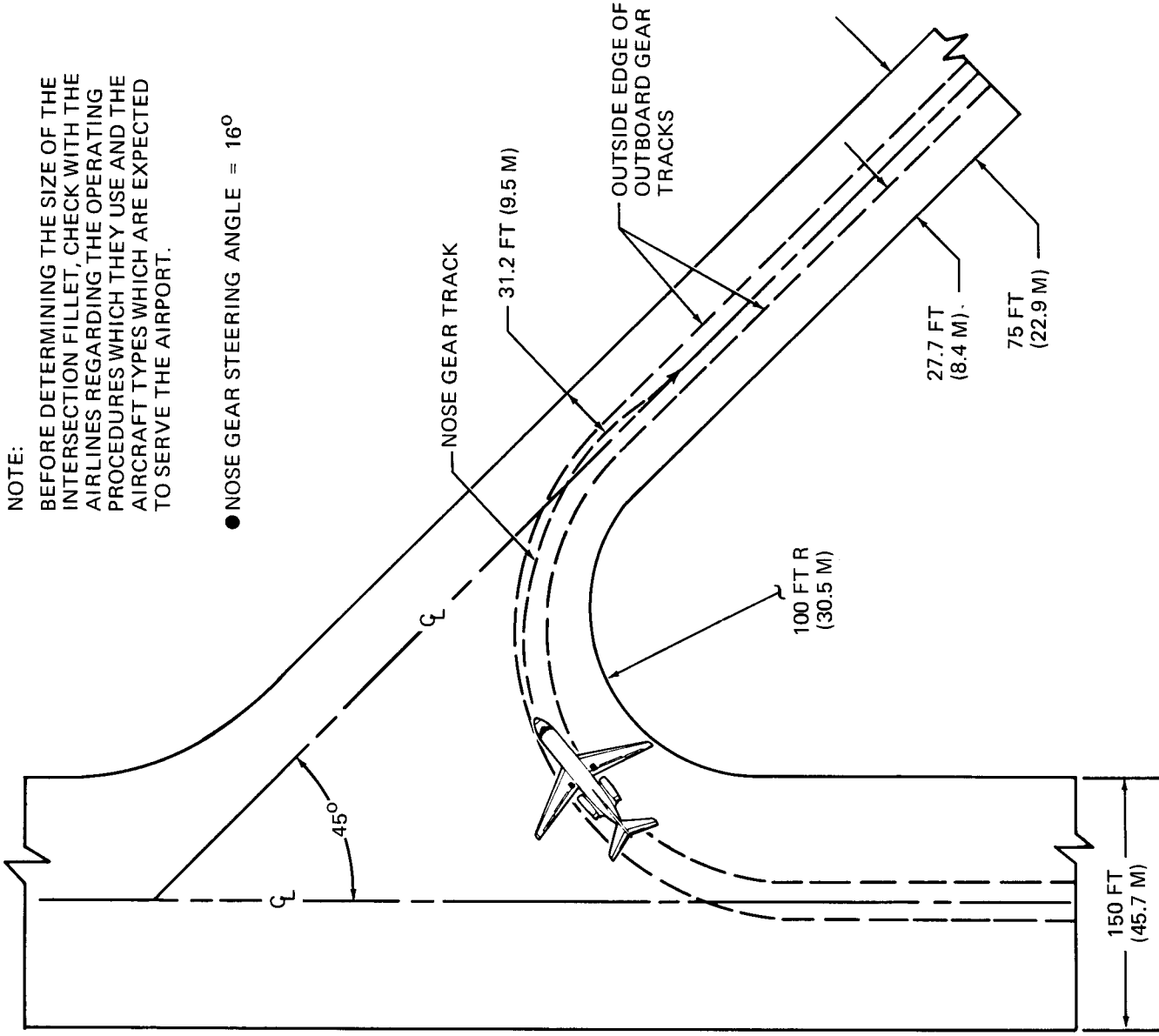

4.4 RUNWAY AND TAXIWAY TURN PATHS
 4.4.1 MORE THAN 90° TURN – RUNWAY TO TAXIWAY TURN
 MODEL DC-9-21

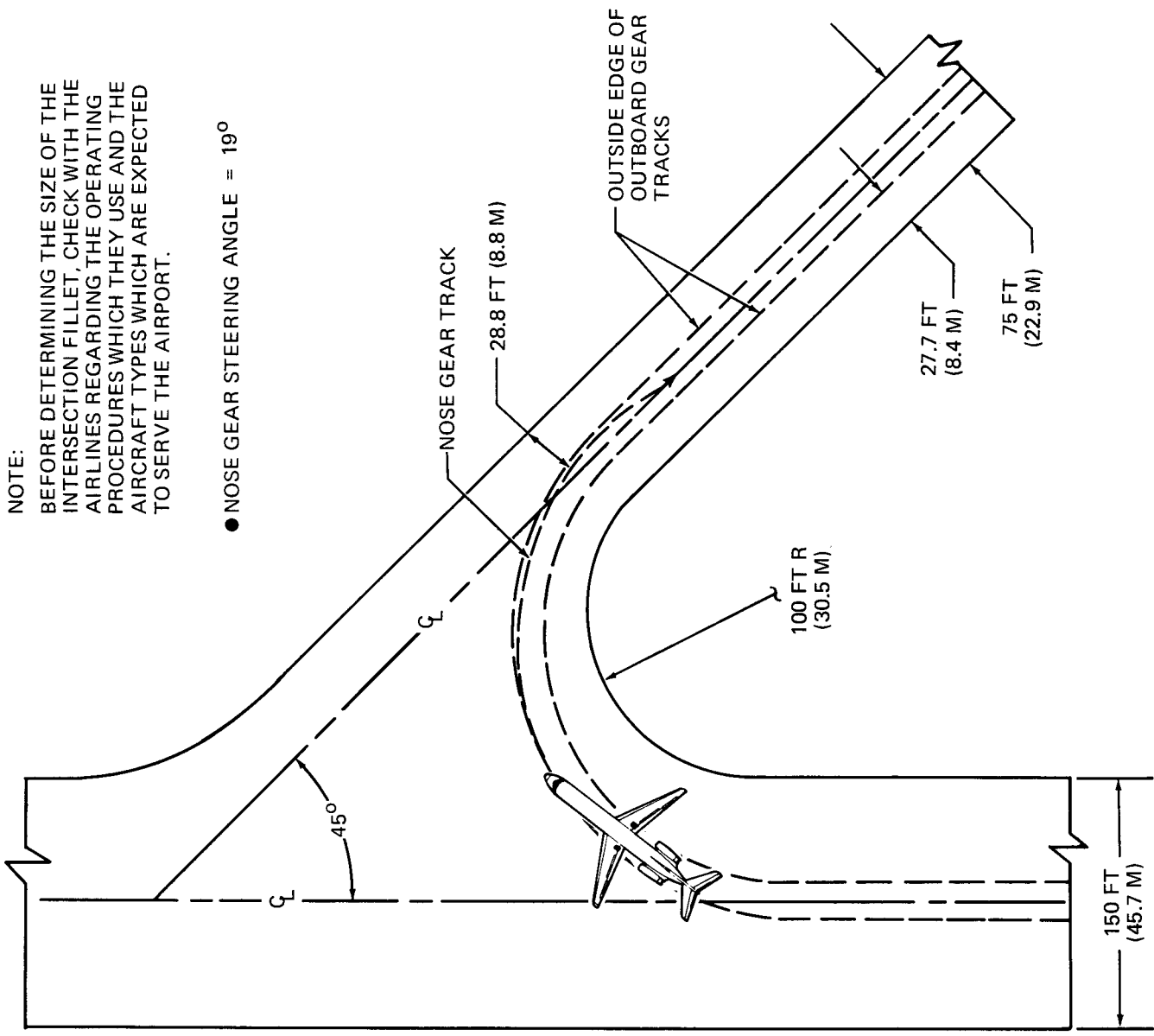

NOTE:
 BEFORE DETERMINING THE SIZE OF THE INTERSECTION FILLET, CHECK WITH THE AIRLINES REGARDING THE OPERATING PROCEDURES WHICH THEY USE AND THE AIRCRAFT TYPES WHICH ARE EXPECTED TO SERVE THE AIRPORT.

● NOSE GEAR STEERING ANGLE = 19°

4.4 RUNWAY AND TAXIWAY TURN PATHS
 4.4.1 MORE THAN 90° TURN – RUNWAY TO TAXIWAY TURN
 MODEL DC-9-32

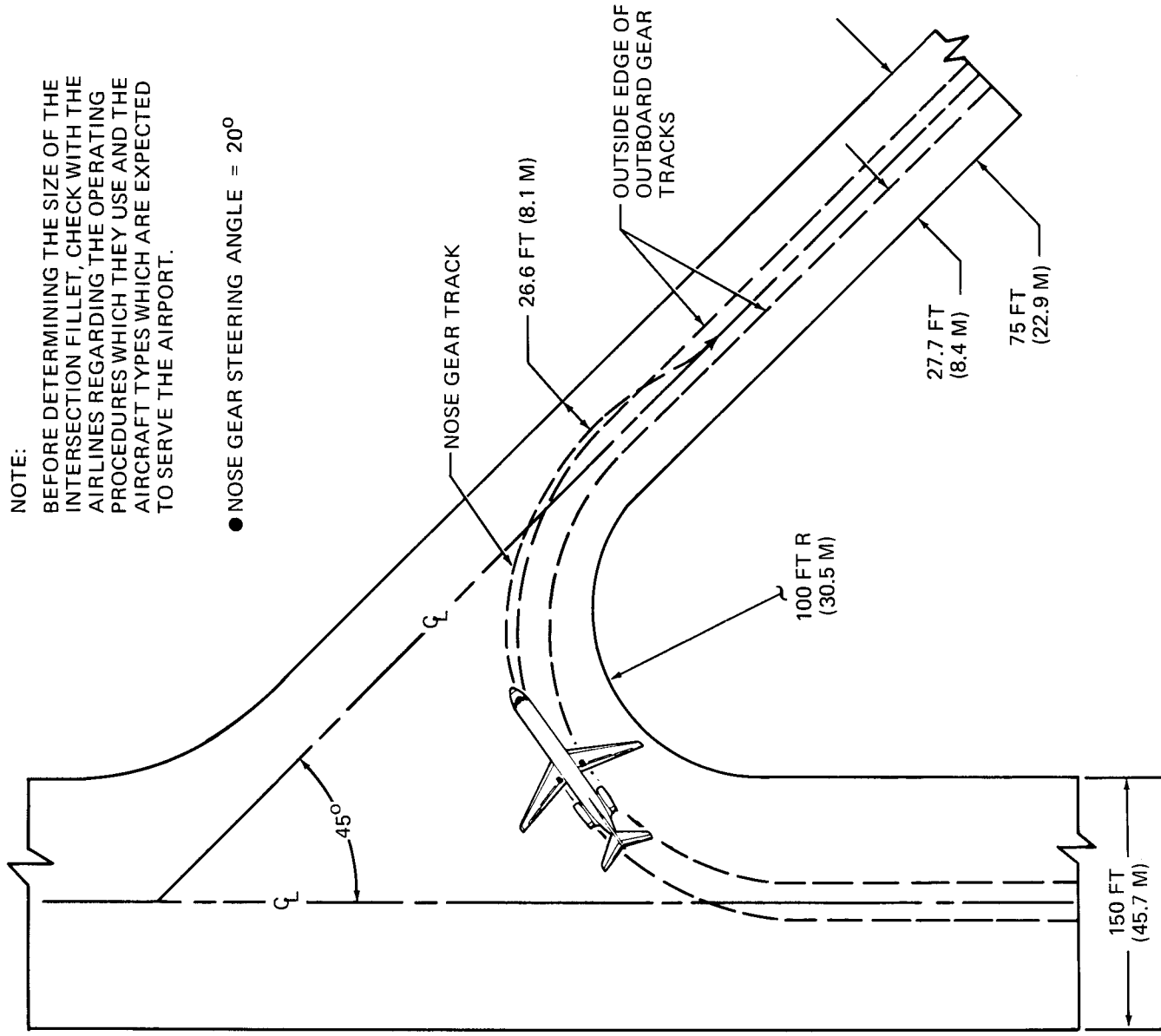

4.4 RUNWAY AND TAXIWAY TURN PATHS

4.4.1 MORE THAN 90° TURN – RUNWAY TO TAXIWAY TURN

MODEL DC-9-41

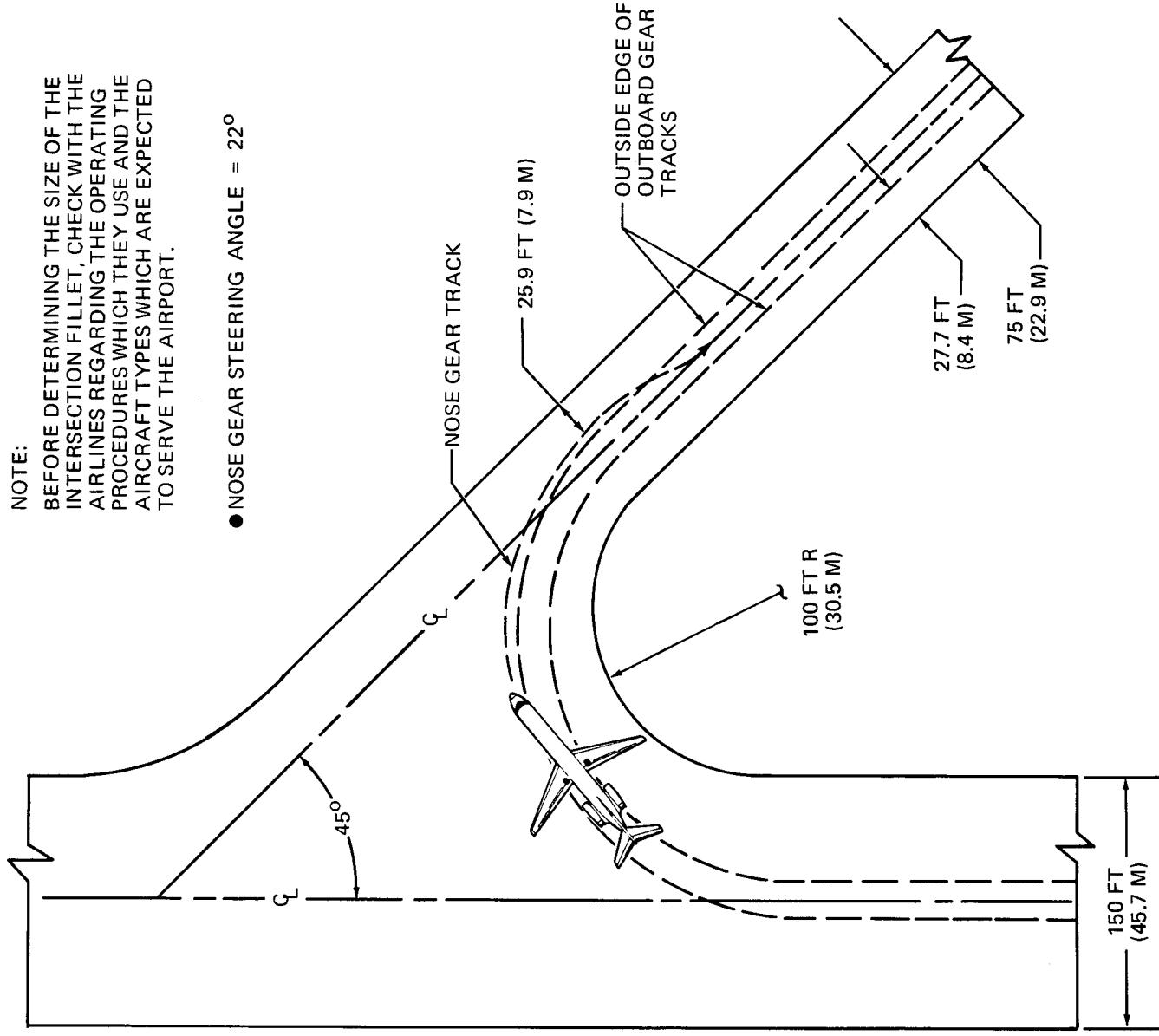

4.4 RUNWAY AND TAXIWAY TURN PATHS

4.4.1 MORE THAN 90° TURN – RUNWAY TO TAXIWAY TURN

MODEL DC-9-51

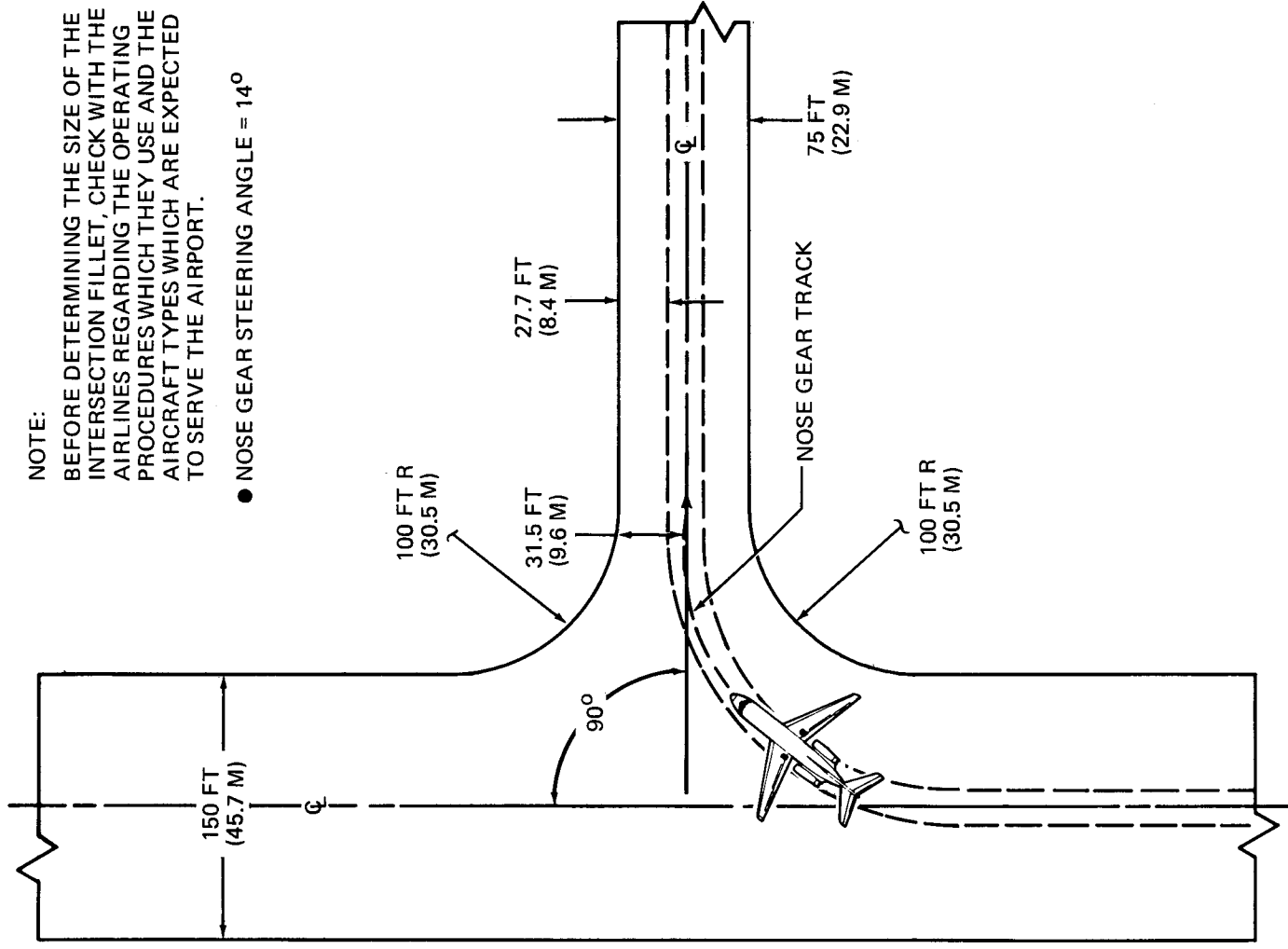

NOTE:

BEFORE DETERMINING THE SIZE OF THE INTERSECTION FILLET, CHECK WITH THE AIRLINES REGARDING THE OPERATING PROCEDURES WHICH THEY USE AND THE AIRCRAFT TYPES WHICH ARE EXPECTED TO SERVE THE AIRPORT.

- NOSE GEAR STEERING ANGLE = 14°

4.4 RUNWAY AND TAXIWAY TURN PATHS

4.4.2 90° TURN – RUNWAY TO TAXIWAY

MODEL DC-9-15

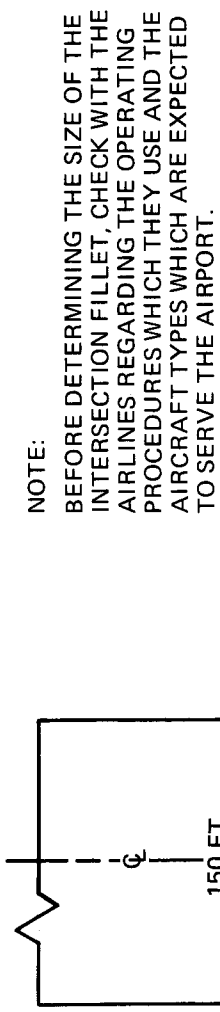

NOTE:

BEFORE DETERMINING THE SIZE OF THE INTERSECTION FILLET, CHECK WITH THE AIRLINES REGARDING THE OPERATING PROCEDURES WHICH THEY USE AND THE AIRCRAFT TYPES WHICH ARE EXPECTED TO SERVE THE AIRPORT.

- NOSE GEAR STEERING ANGLE = 14°

4.4 RUNWAY AND TAXIWAY TURN PATHS

4.4.2 90° TURN – RUNWAY TO TAXIWAY

MODEL DC-9-21

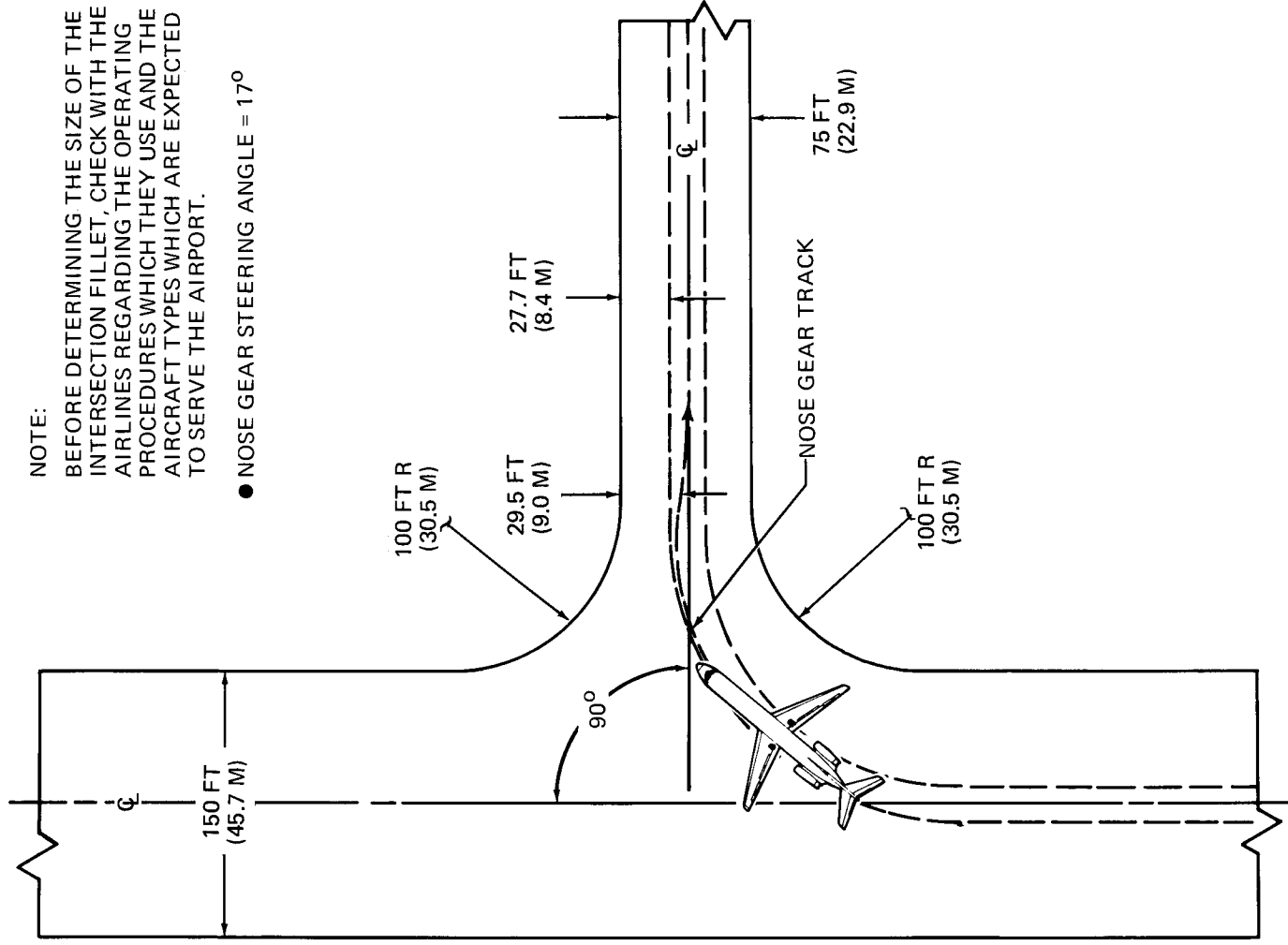

4.4 RUNWAY AND TAXIWAY TURN PATHS

4.4.2 90° TURN – RUNWAY TO TAXIWAY

MODEL DC-9-32

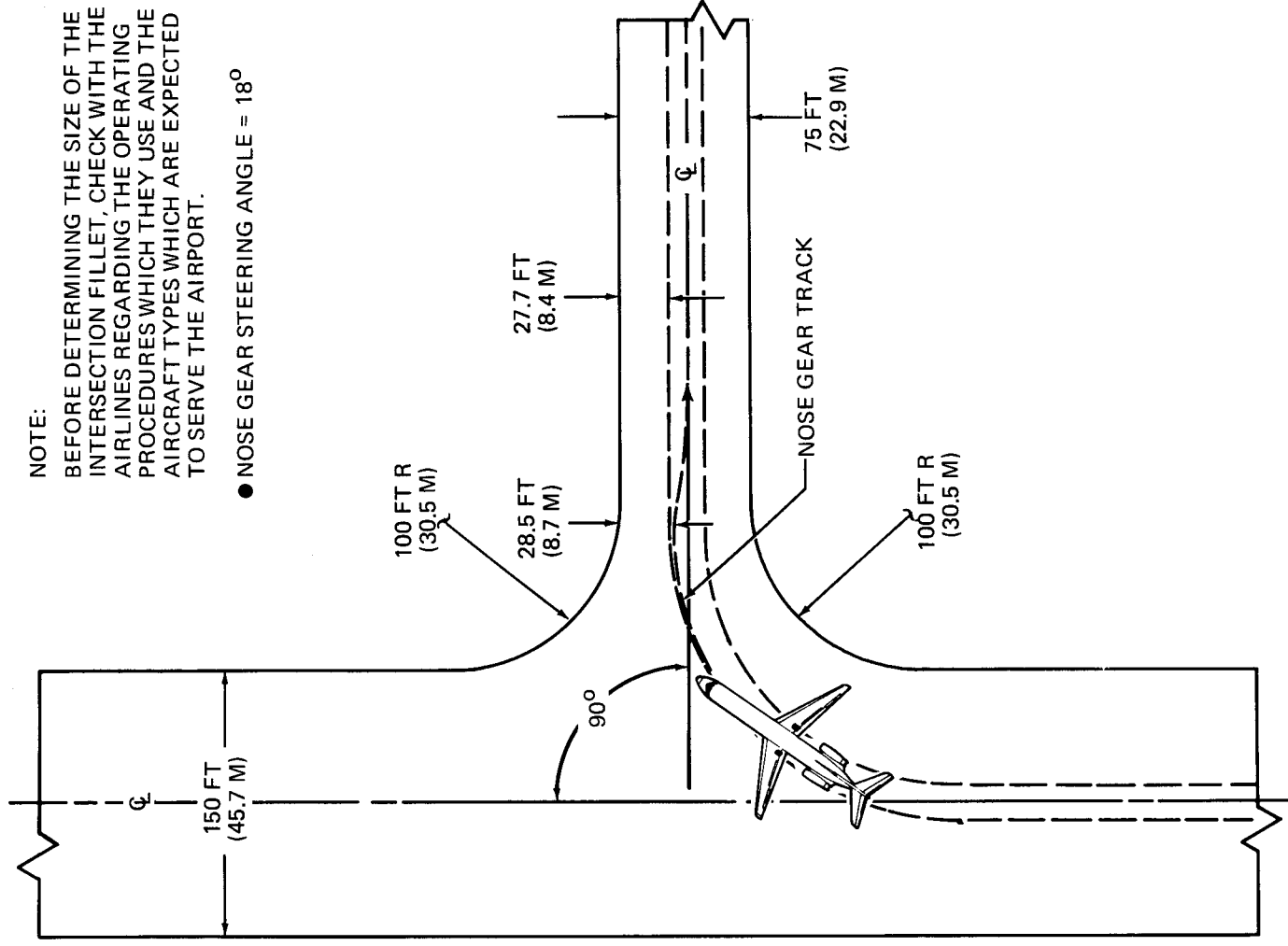

NOTE:

BEFORE DETERMINING THE SIZE OF THE INTERSECTION FILLET, CHECK WITH THE AIRLINES REGARDING THE OPERATING PROCEDURES WHICH THEY USE AND THE AIRCRAFT TYPES WHICH ARE EXPECTED TO SERVE THE AIRPORT.

- NOSE GEAR STEERING ANGLE = 18°

4.4 RUNWAY AND TAXIWAY TURN PATHS

4.4.2 90° TURN - RUNWAY TO TAXIWAY

MODEL DC-9-41

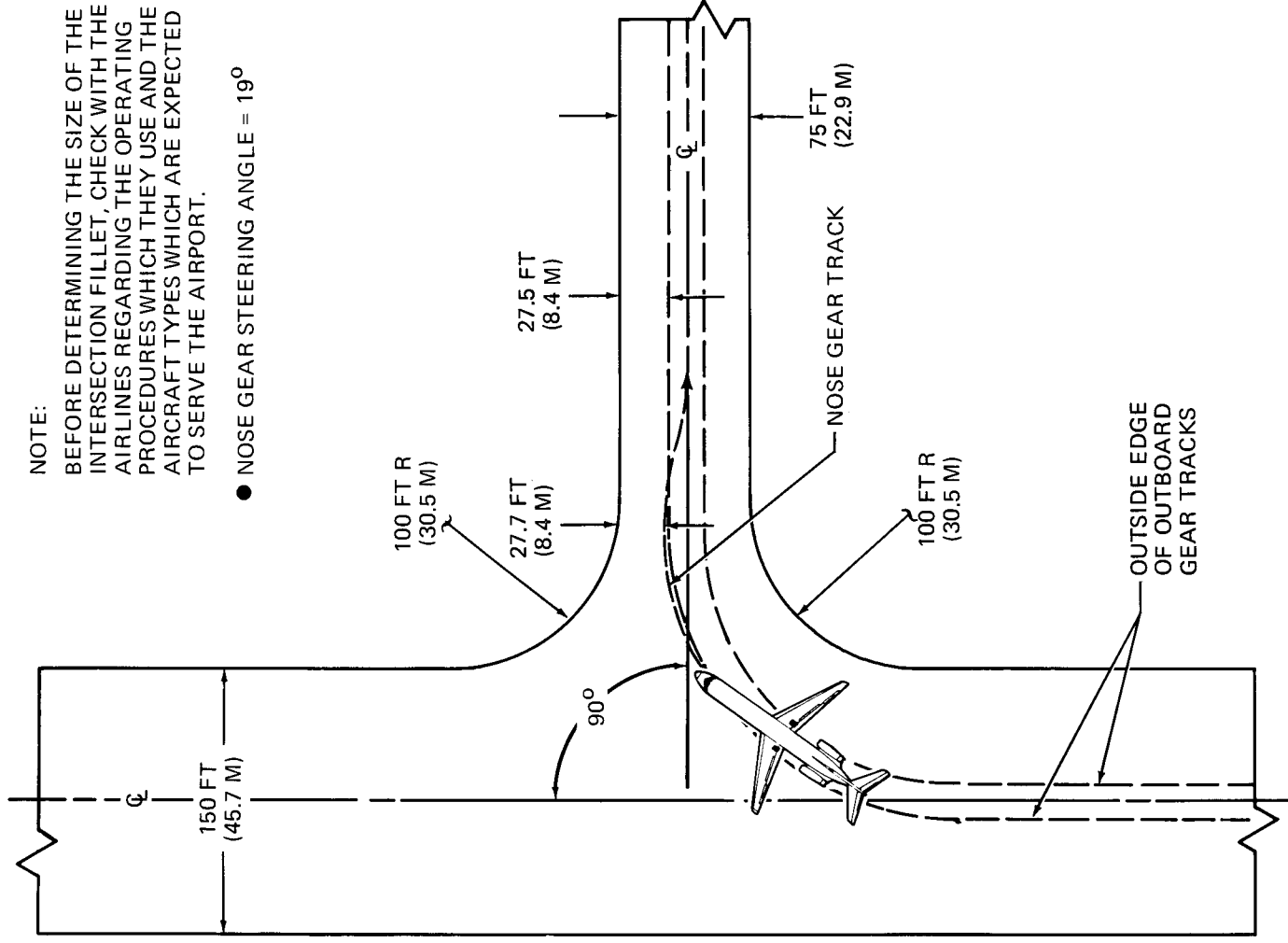

4.4 RUNWAY AND TAXIWAY TURN PATHS

4.4.2 90° TURN – RUNWAY TO TAXIWAY

MODEL DC-9-51

NOTE:

BEFORE DETERMINING THE SIZE OF THE INTERSECTION FILLET, CHECK WITH THE AIRLINES REGARDING THE OPERATING PROCEDURES WHICH THEY USE AND THE AIRCRAFT TYPES WHICH ARE EXPECTED TO SERVE THE AIRPORT.

● NOSE GEAR STEERING ANGLE = 18°

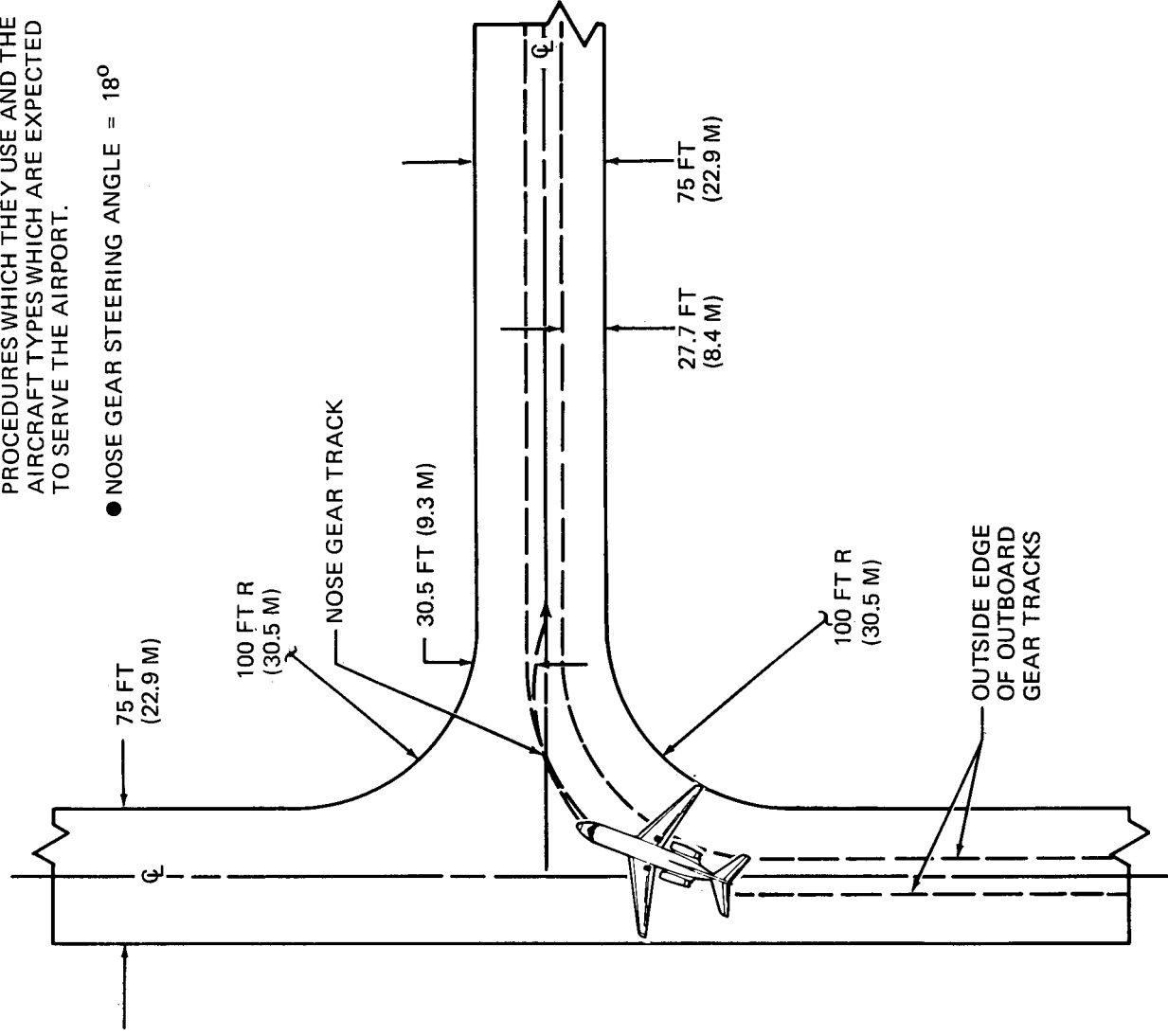

4.4 RUNWAY AND TAXIWAY TURN PATHS 4.4.3 90° TURN - TAXIWAY TO TAXIWAY MODEL DC-9-15

NOSE GEAR TRACKING
BEYOND TAXIWAY CENTERLINE

NOTE:

BEFORE DETERMINING THE SIZE OF THE INTERSECTION FILLET, CHECK WITH THE AIRLINES REGARDING THE OPERATING PROCEDURES WHICH THEY USE AND THE AIRCRAFT TYPES WHICH ARE EXPECTED TO SERVE THE AIRPORT.

- NOSE GEAR STEERING ANGLE = 18°

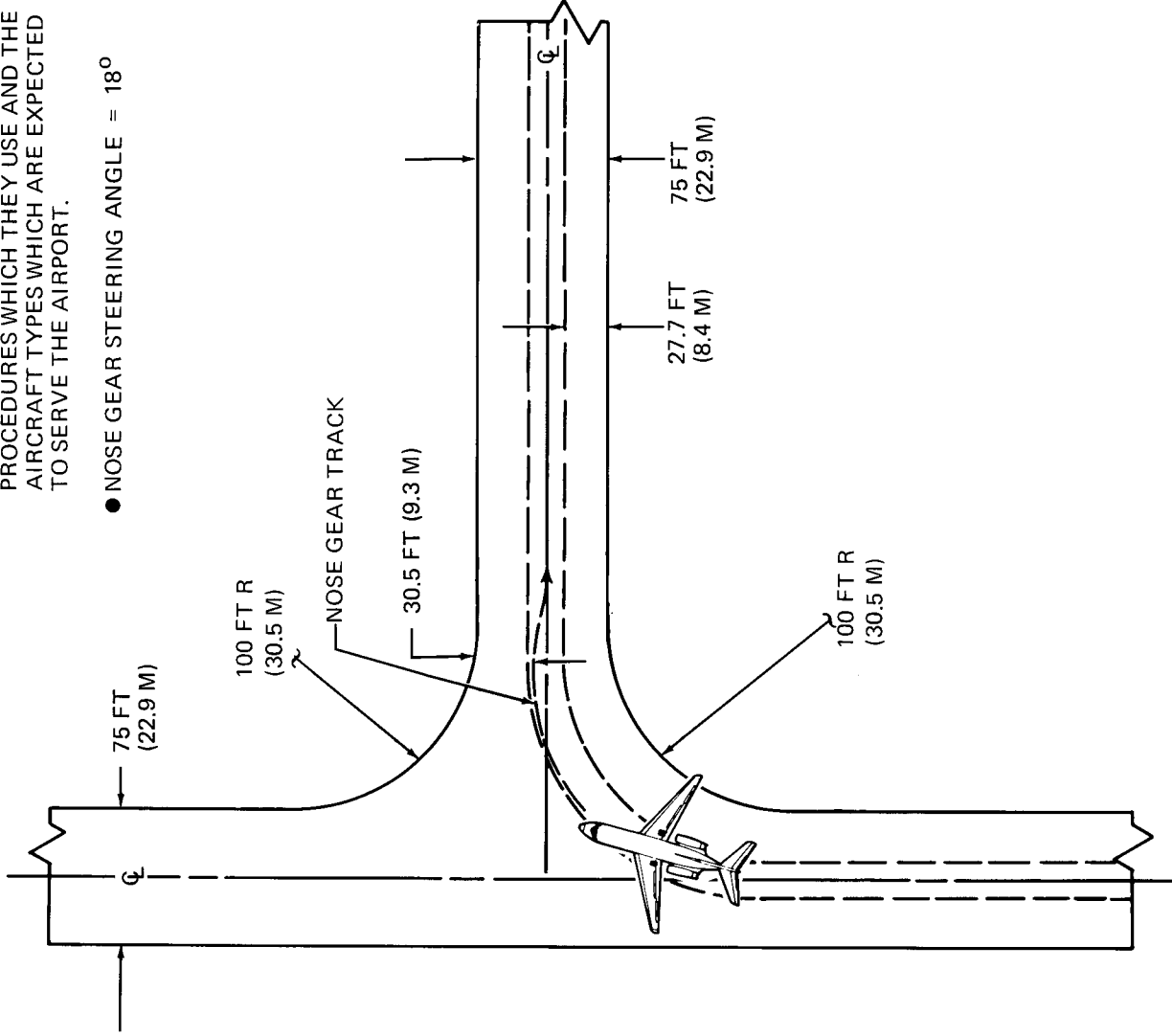

4.4 RUNWAY AND TAXIWAY TURN PATHS

4.4.3 90° TURN – TAXIWAY TO TAXIWAY

MODEL DC-9-21

NOSE GEAR TRACKING
BEYOND TAXIWAY CENTERLINE

NOTE:
 BEFORE DETERMINING THE SIZE OF THE INTERSECTION FILLET, CHECK WITH THE AIRLINES REGARDING THE OPERATING PROCEDURES WHICH THEY USE AND THE AIRCRAFT TYPES WHICH ARE EXPECTED TO SERVE THE AIRPORT.

● NOSE GEAR STEERING ANGLE = 21°

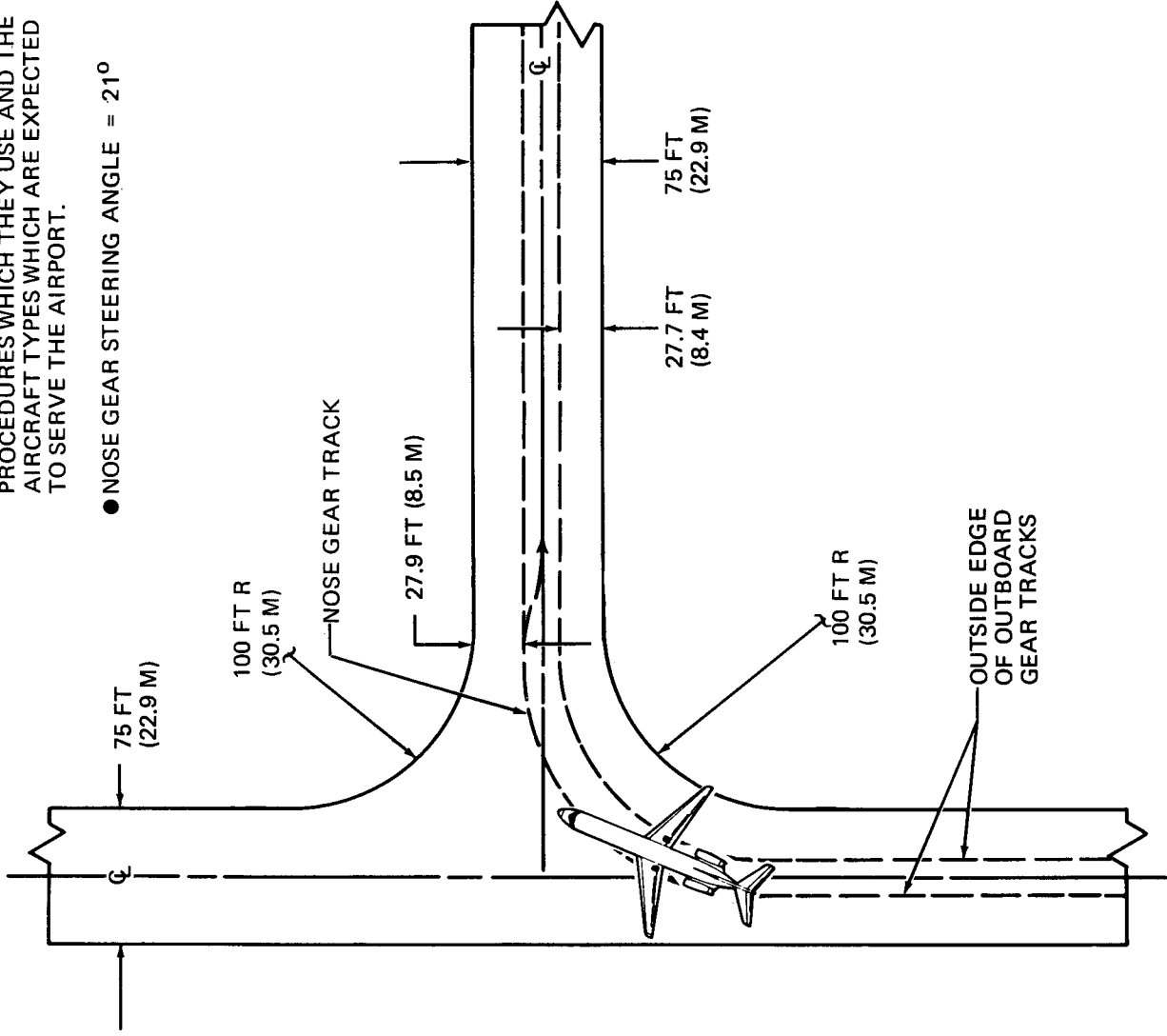

4.4 RUNWAY AND TAXIWAY TURN PATHS

4.4.3 90° TURN - TAXIWAY TO TAXIWAY

MODEL DC-9-32

NOSE GEAR TRACKING
 BEYOND TAXIWAY CENTERLINE

NOTE:

BEFORE DETERMINING THE SIZE OF THE INTERSECTION FILLET, CHECK WITH THE AIRLINES REGARDING THE OPERATING PROCEDURES WHICH THEY USE AND THE AIRCRAFT TYPES WHICH ARE EXPECTED TO SERVE THE AIRPORT.

● NOSE GEAR STEERING ANGLE = 22°

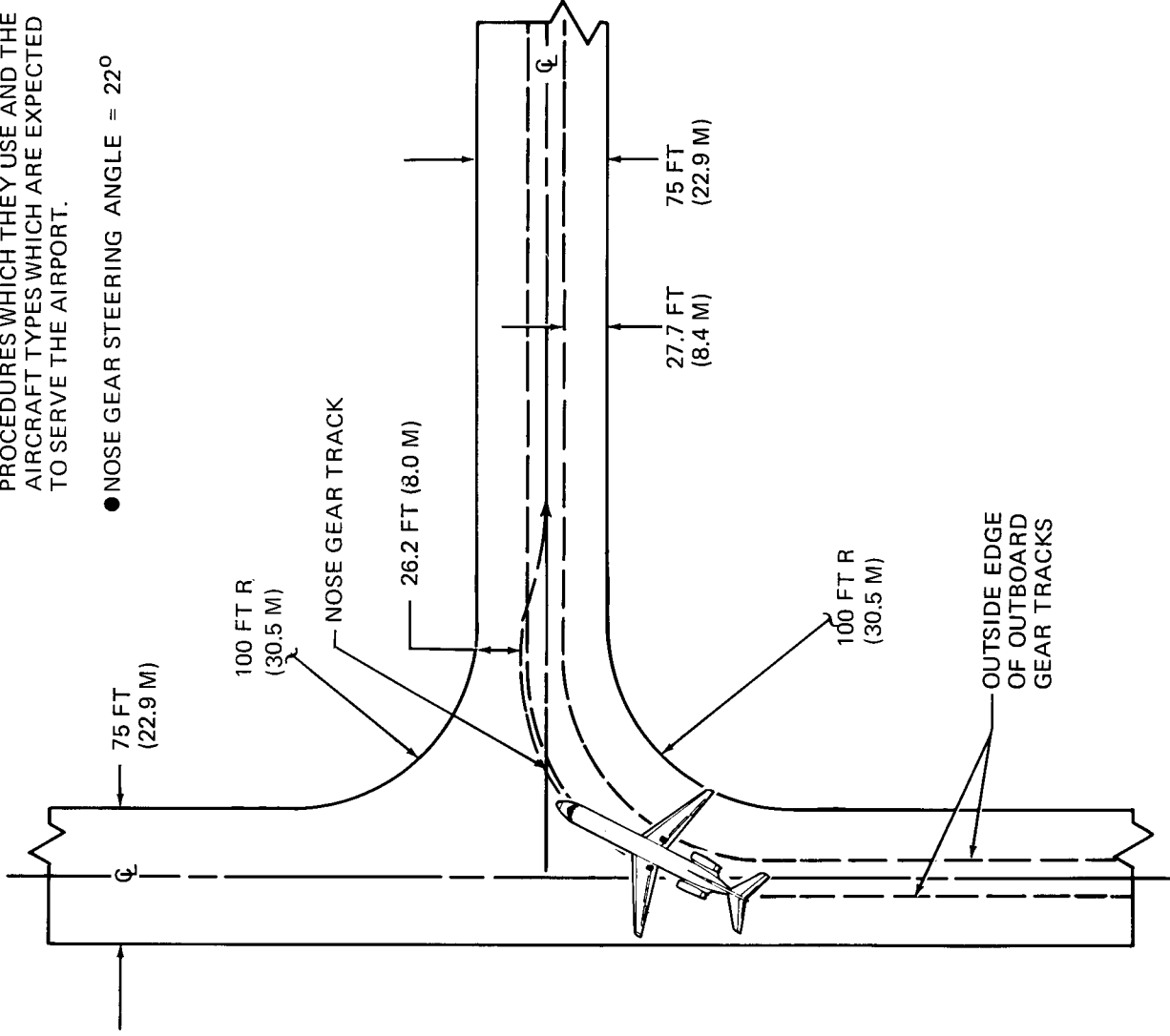

4.4 RUNWAY AND TAXIWAY TURN PATHS

4.4.3 90° TURN – TAXIWAY TO TAXIWAY

MODEL DC-9-41

NOSE GEAR TRACKING
BEYOND TAXIWAY CENTERLINE

NOTE:

BEFORE DETERMINING THE SIZE OF THE INTERSECTION FILLET, CHECK WITH THE AIRLINES REGARDING THE OPERATING PROCEDURES WHICH THEY USE AND THE AIRCRAFT TYPES WHICH ARE EXPECTED TO SERVE THE AIRPORT.

● NOSE GEAR STEERING ANGLE = 24°

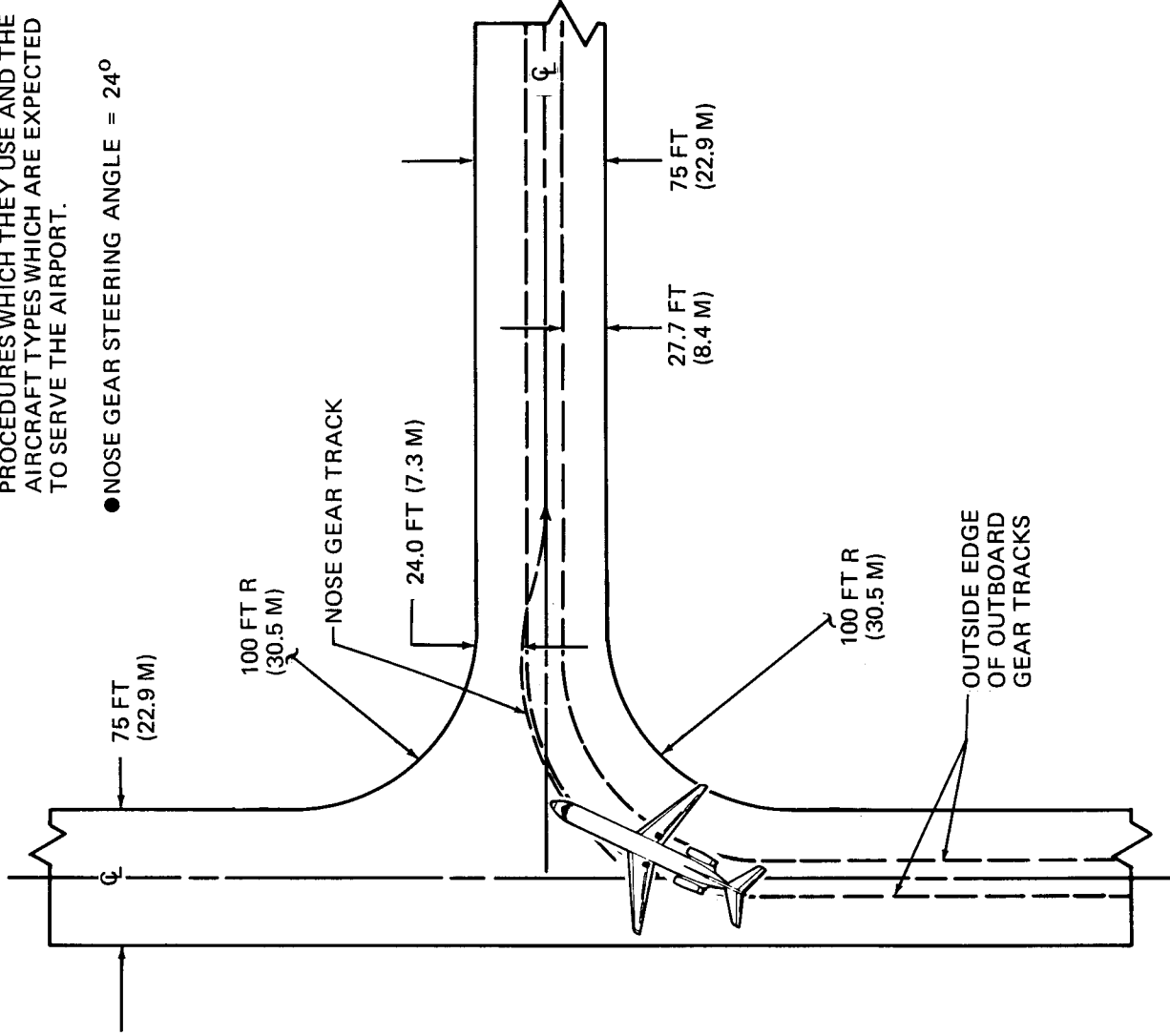

4.4 RUNWAY AND TAXIWAY TURN PATHS

4.4.3 90° TURN – TAXIWAY TO TAXIWAY

MODEL DC-9-51

NOSE GEAR TRACKING
BEYOND TAXIWAY CENTERLINE

NOTE:

BEFORE DETERMINING THE SIZE OF THE INTERSECTION FILLET, CHECK WITH THE AIRLINES REGARDING THE OPERATING PROCEDURES WHICH THEY USE AND THE AIRCRAFT TYPES WHICH ARE EXPECTED TO SERVE THE AIRPORT.

- SYMMETRICAL THRUST
- MID-CG

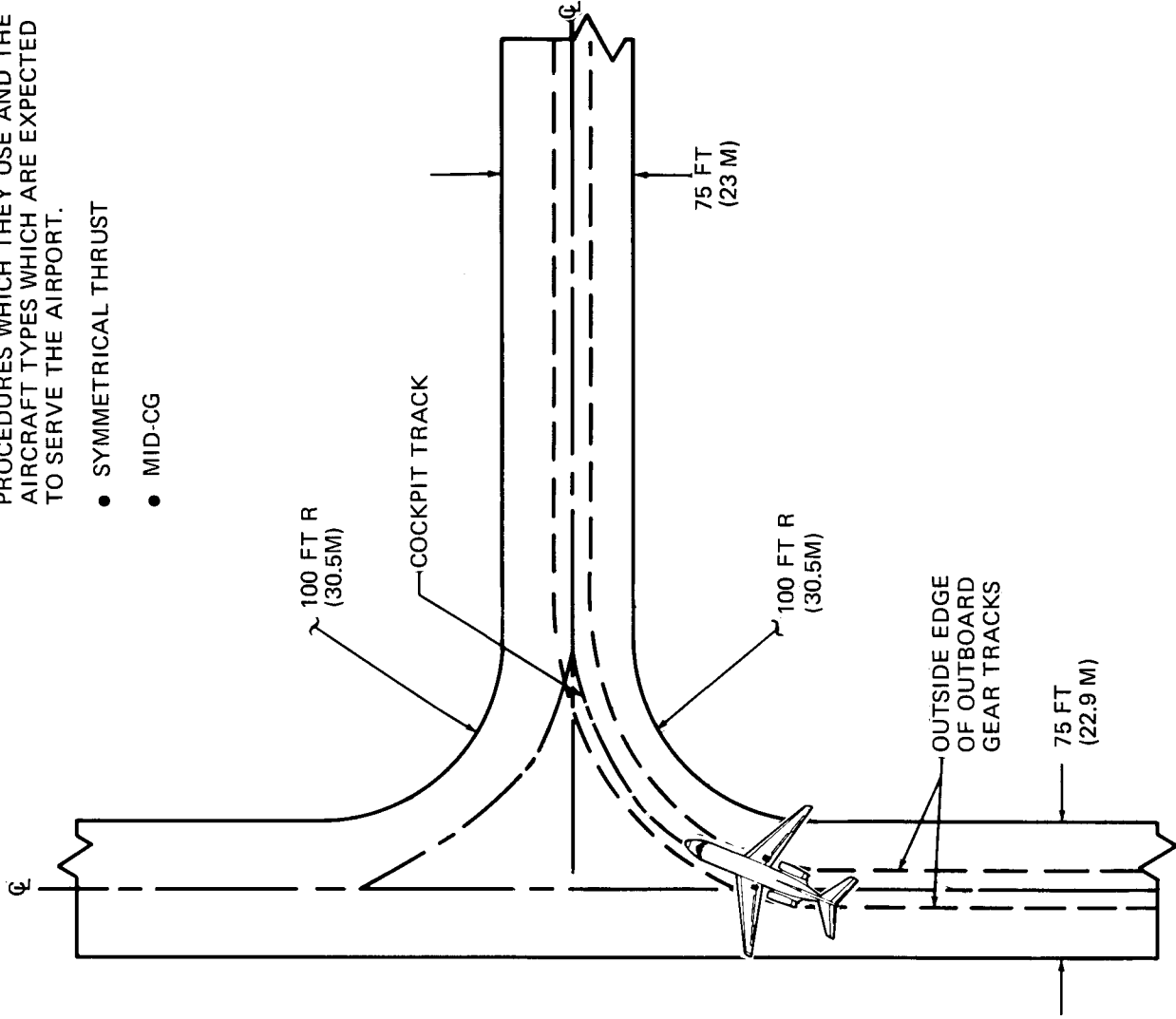

4.4 RUNWAY AND TAXIWAY TURN PATHS

4.4.4 90° TURN – TAXIWAY TO TAXIWAY

MODEL DC-9-15
COCKPIT TRACKS
CENTERLINE TO CENTERLINE

NOTE:

BEFORE DETERMINING THE SIZE OF THE INTERSECTION FILLET, CHECK WITH THE AIRLINES REGARDING THE OPERATING PROCEDURES WHICH THEY USE AND THE AIRCRAFT TYPES WHICH ARE EXPECTED TO SERVE THE AIRPORT.

- SYMMETRICAL THRUST
- MID-CG

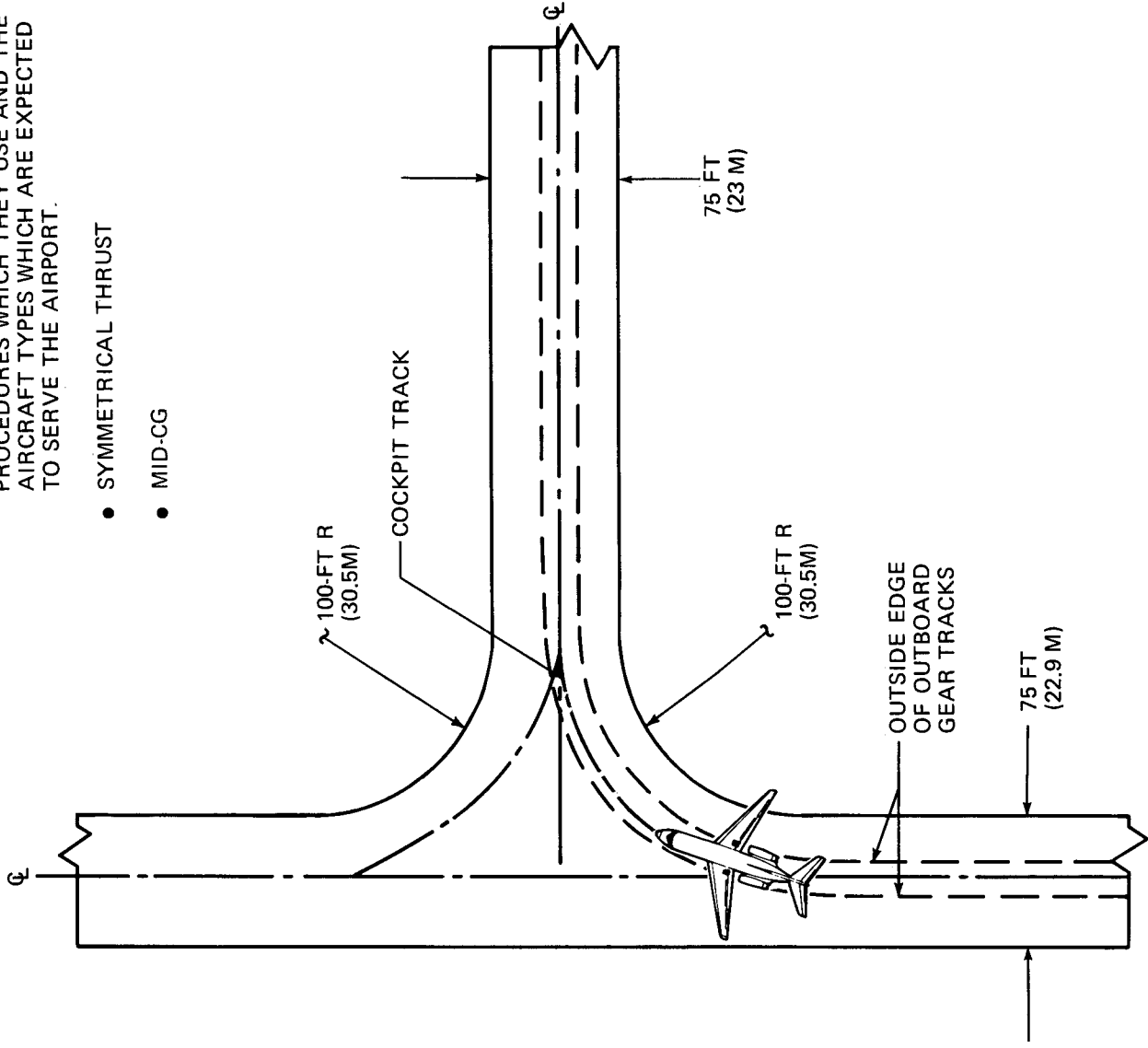

4.4 RUNWAY AND TAXIWAY TURN PATHS

4.4.4 90° TURN – TAXIWAY TO TAXIWAY

MODEL DC-9-21

COCKPIT TRACKS
CENTERLINE TO CENTERLINE

NOTE:

BEFORE DETERMINING THE SIZE OF THE INTERSECTION FILLET, CHECK WITH THE AIRLINES REGARDING THE OPERATING PROCEDURES WHICH THEY USE AND THE AIRCRAFT TYPES WHICH ARE EXPECTED TO SERVE THE AIRPORT.

- SYMMETRICAL THRUST
- MID-CG

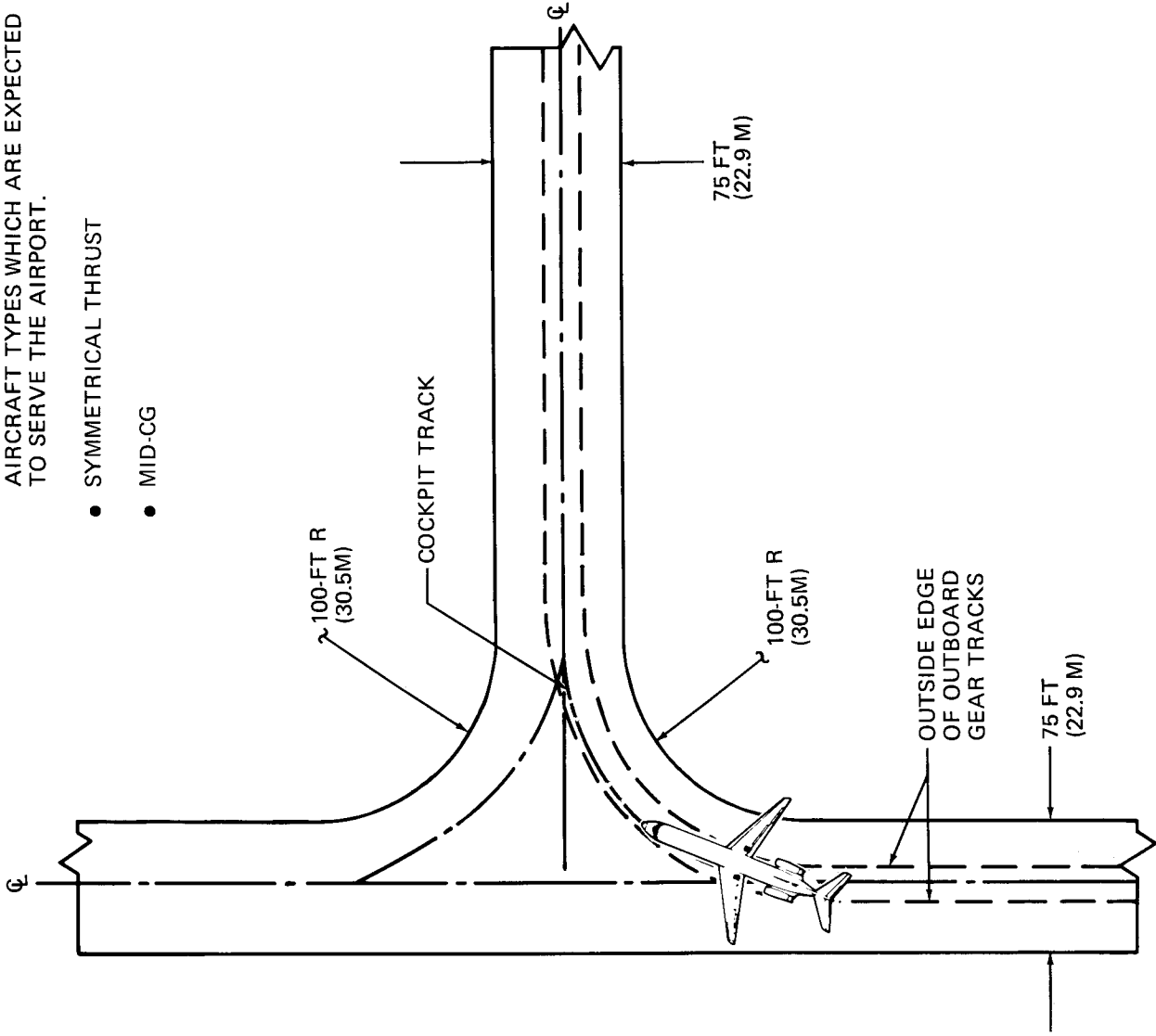

4.4 RUNWAY AND TAXIWAY TURN PATHS

4.4.4 90° TURN – TAXIWAY TO TAXIWAY MODEL DC-9-32

COCKPIT TRACKS
CENTERLINE TO CENTERLINE

NOTE:

BEFORE DETERMINING THE SIZE OF THE INTERSECTION FILLET, CHECK WITH THE AIRLINES REGARDING THE OPERATING PROCEDURES WHICH THEY USE AND THE AIRCRAFT TYPES WHICH ARE EXPECTED TO SERVE THE AIRPORT.

- SYMMETRICAL THRUST
- MID-CG

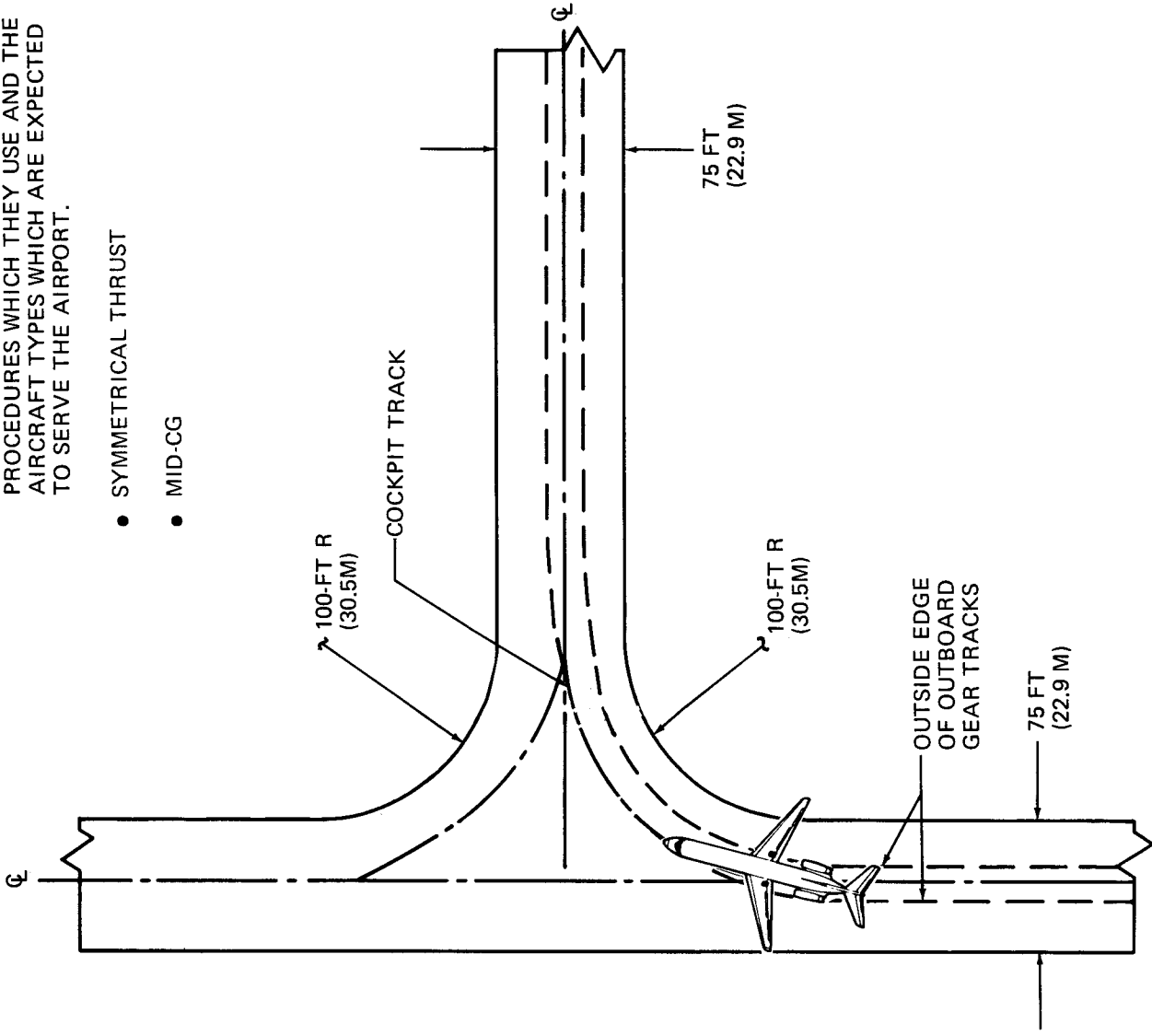

4.4 RUNWAY AND TAXIWAY TURN PATHS

4.4.4 90° TURN – TAXIWAY TO TAXIWAY

MODEL DC-9-41

COCKPIT TRACKS
CENTERLINE TO CENTERLINE

NOTE:

BEFORE DETERMINING THE SIZE OF THE INTERSECTION FILLET, CHECK WITH THE AIRLINES REGARDING THE OPERATING PROCEDURES WHICH THEY USE AND THE AIRCRAFT TYPES WHICH ARE EXPECTED TO SERVE THE AIRPORT.

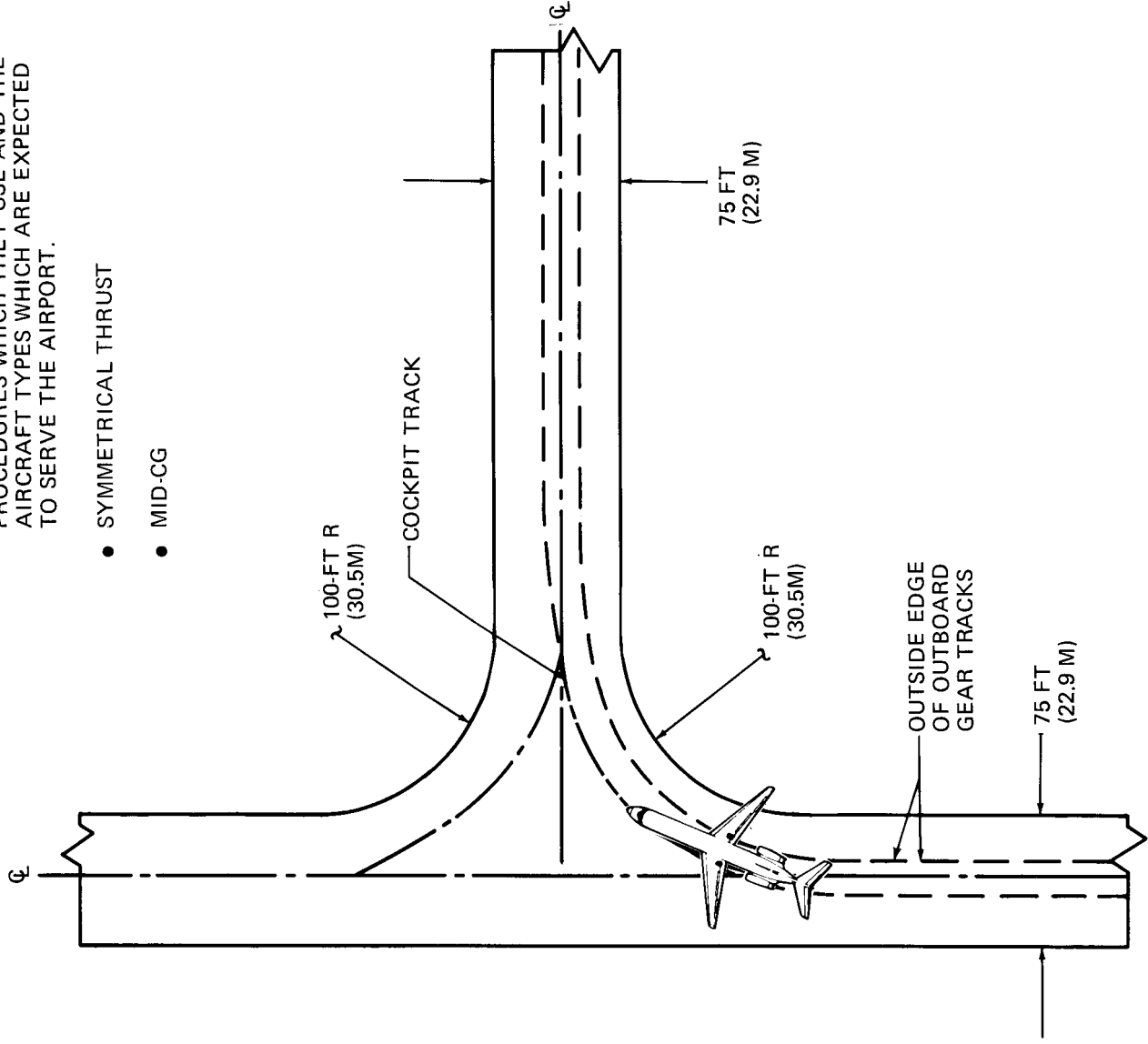

4.4 RUNWAY AND TAXIWAY TURN PATHS

4.4.4 90° TURN - TAXIWAY TO TAXIWAY

MODEL DC-9-51

COCKPIT TRACKS
CENTERLINE TO CENTERLINE

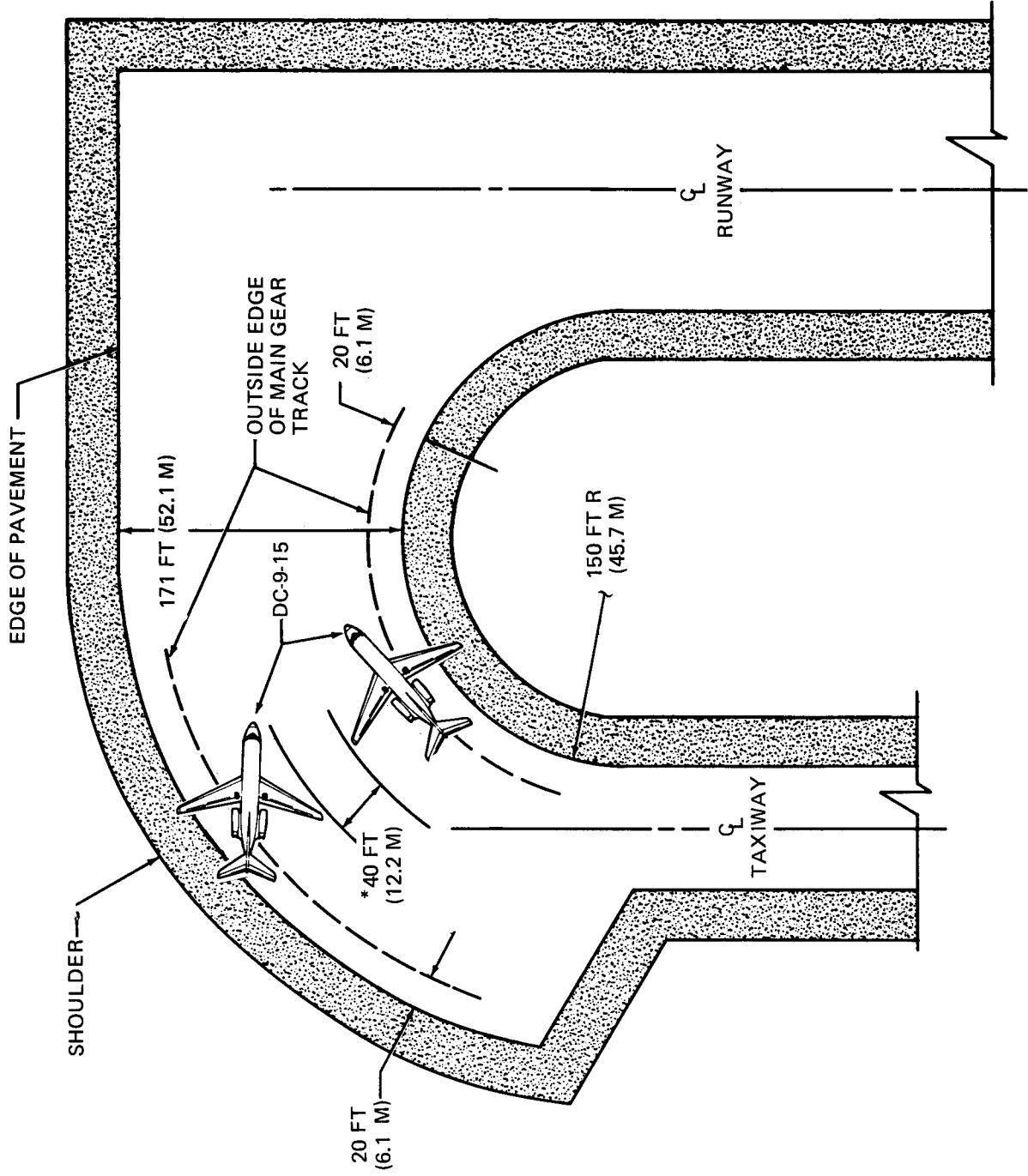

*MINIMUM CLEARANCE FOR MOVING AIRCRAFT = 40 FT (12.2 M)

NOTE:
COORDINATE WITH USING AIRLINES FOR SPECIFIC REQUIREMENTS PRIOR TO FACILITY DESIGN

4.5 RUNWAY HOLDING BAY (APRON) MODEL DC-9-15

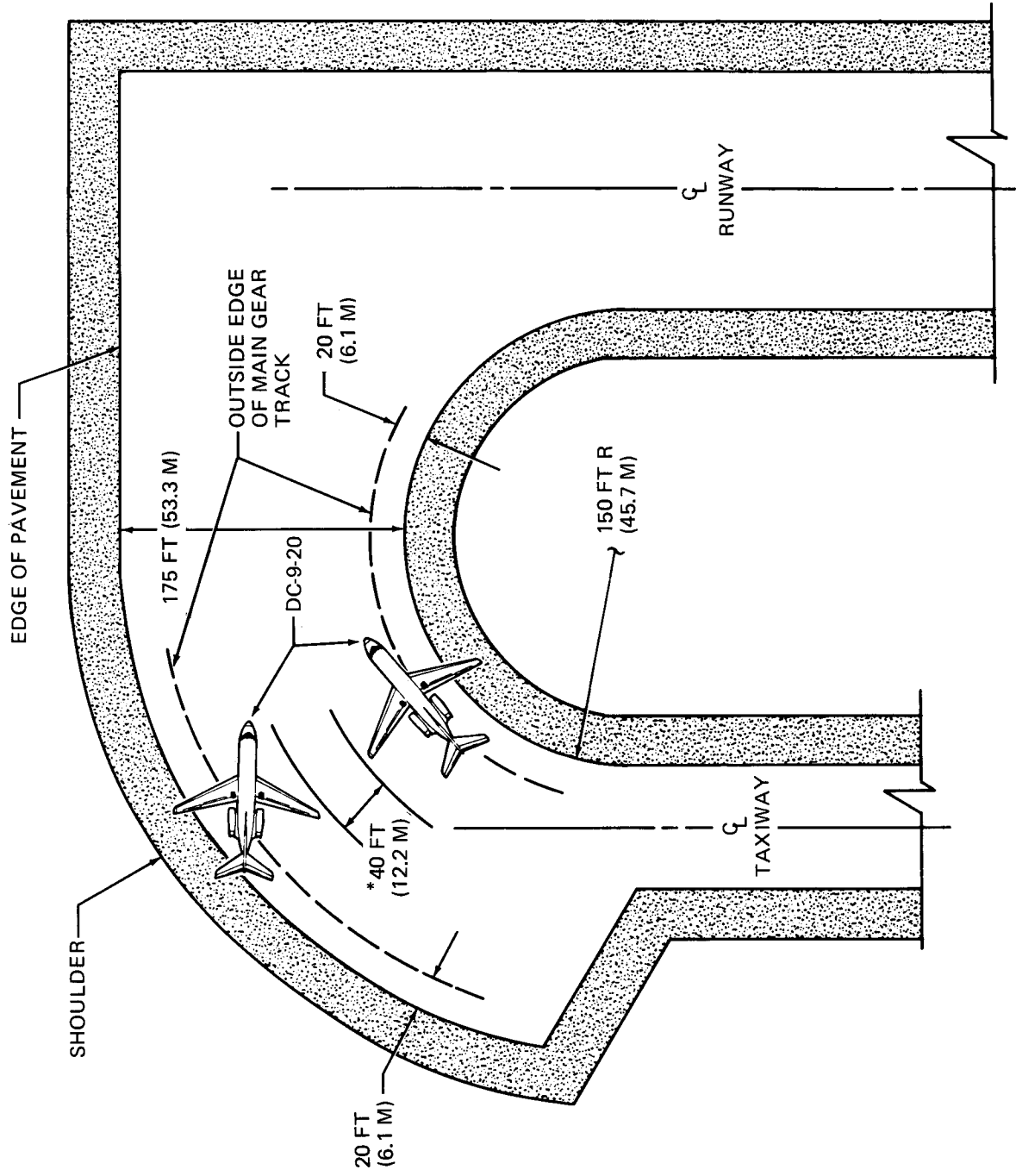

NOTE:

*MINIMUM CLEARANCE FOR MOVING AIRCRAFT = 40 FT (12.2 M)

COORDINATE WITH USING AIRLINES FOR SPECIFIC REQUIREMENTS PRIOR TO FACILITY DESIGN

4.5 RUNWAY HOLDING BAY (APRON) MODEL DC-9-21

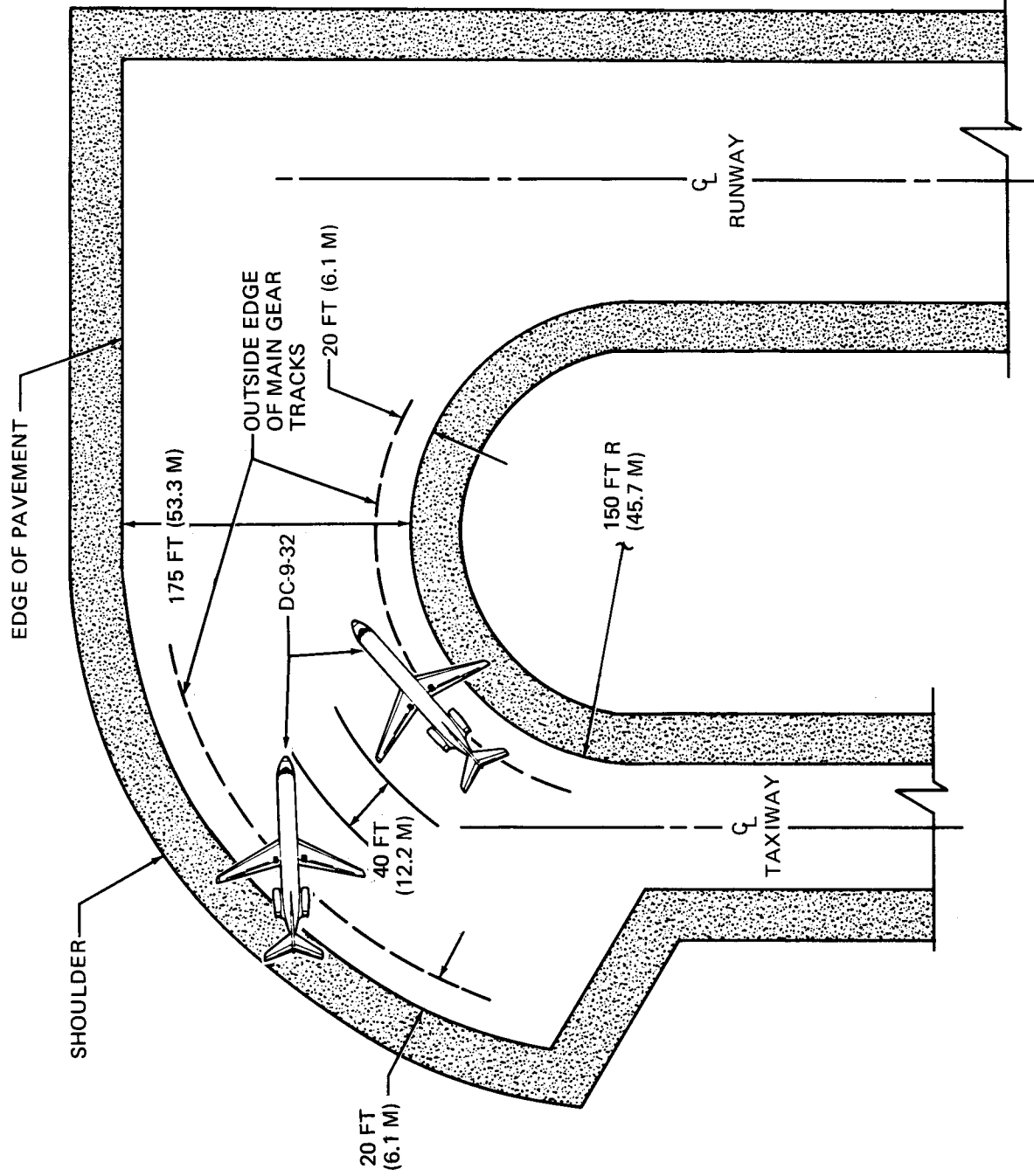

*MINIMUM CLEARANCE FOR MOVING AIRCRAFT = 40 FT (12.2 M)

NOTE:
 COORDINATE WITH USING AIRLINES FOR SPECIFIC REQUIREMENTS PRIOR TO FACILITY DESIGN

4.5 RUNWAY HOLDING BAY (APRON) MODEL DC-9-32

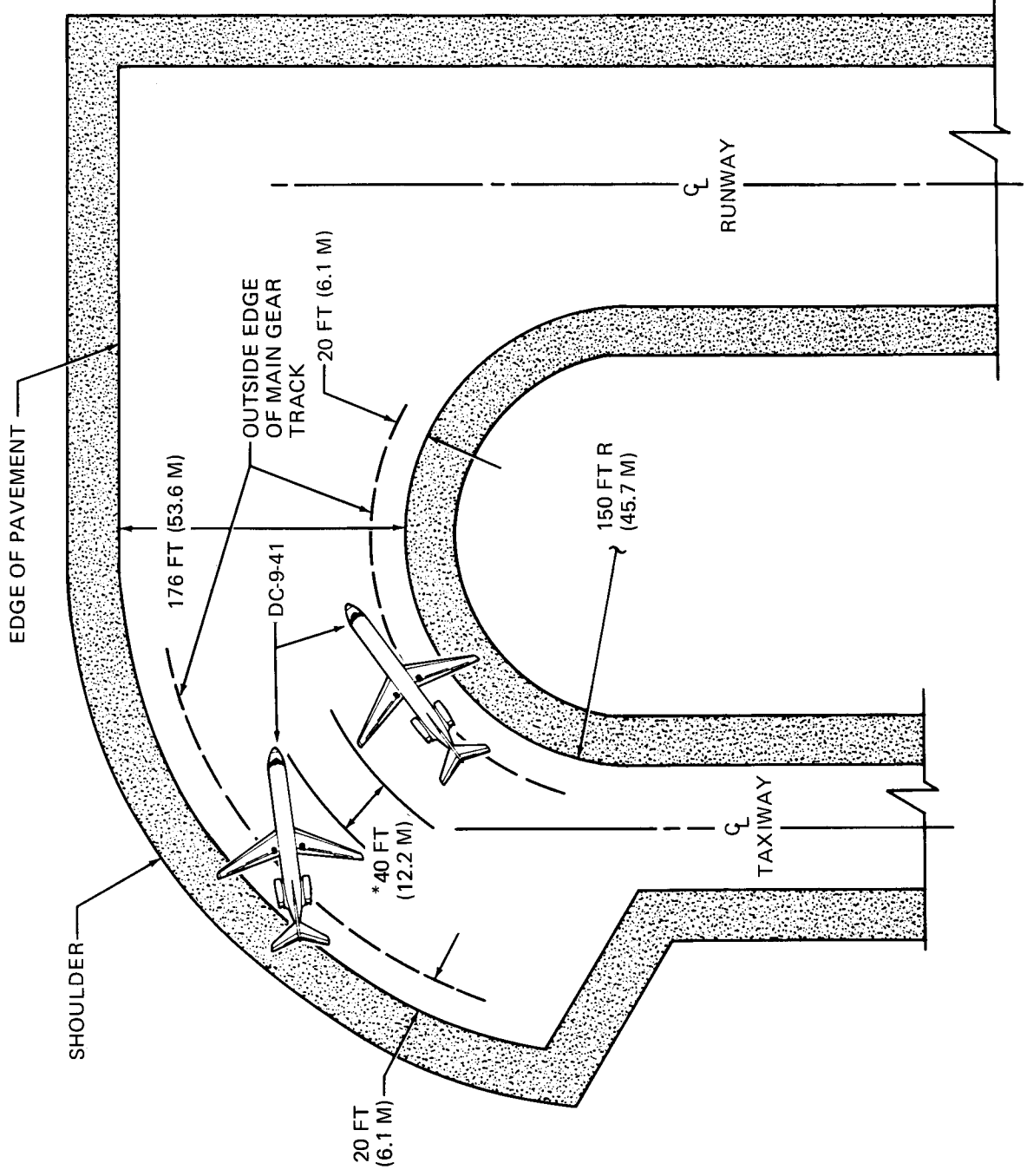

*MINIMUM CLEARANCE FOR MOVING AIRCRAFT = 40 FT (12.2 M)

NOTE:

COORDINATE WITH USING AIRLINES FOR SPECIFIC REQUIREMENTS PRIOR TO FACILITY DESIGN

4.5 RUNWAY HOLDING BAY (APRON) MODEL DC-9-41

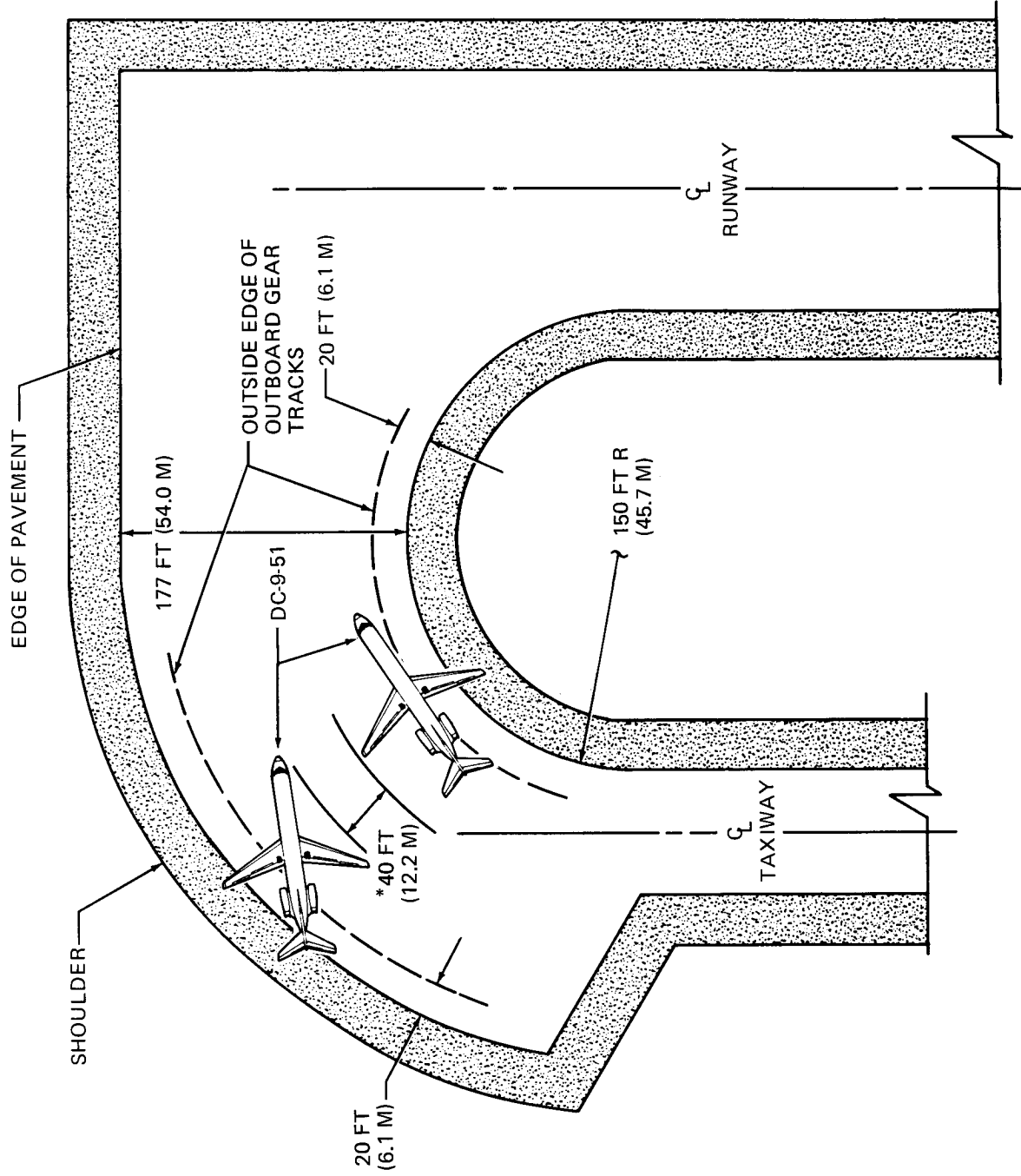

*MINIMUM CLEARANCE FOR MOVING AIRCRAFT = 40 FT (12.2 M)

NOTE:
 COORDINATE WITH USING AIRLINES FOR SPECIFIC REQUIREMENTS PRIOR TO FACILITY DESIGN

4.5 RUNWAY HOLDING BAY (APRON) MODEL DC-9-51

5.0 TERMINAL SERVICING

- 5.1 Airplane Servicing Arrangement (Typical)**
- 5.2 Terminal Operations, Turnaround Station**
- 5.3 Terminal Operations, En Route Station**
- 5.4 Ground Service Connections**
- 5.5 Ground Service Connection Data**
- 5.6 Engine Starting Pneumatic Requirements**
- 5.7 Ground Pneumatic Power Requirements**
- 5.8 Preconditioned Airflow Requirements**
- 5.9 Ground Towing Requirements**

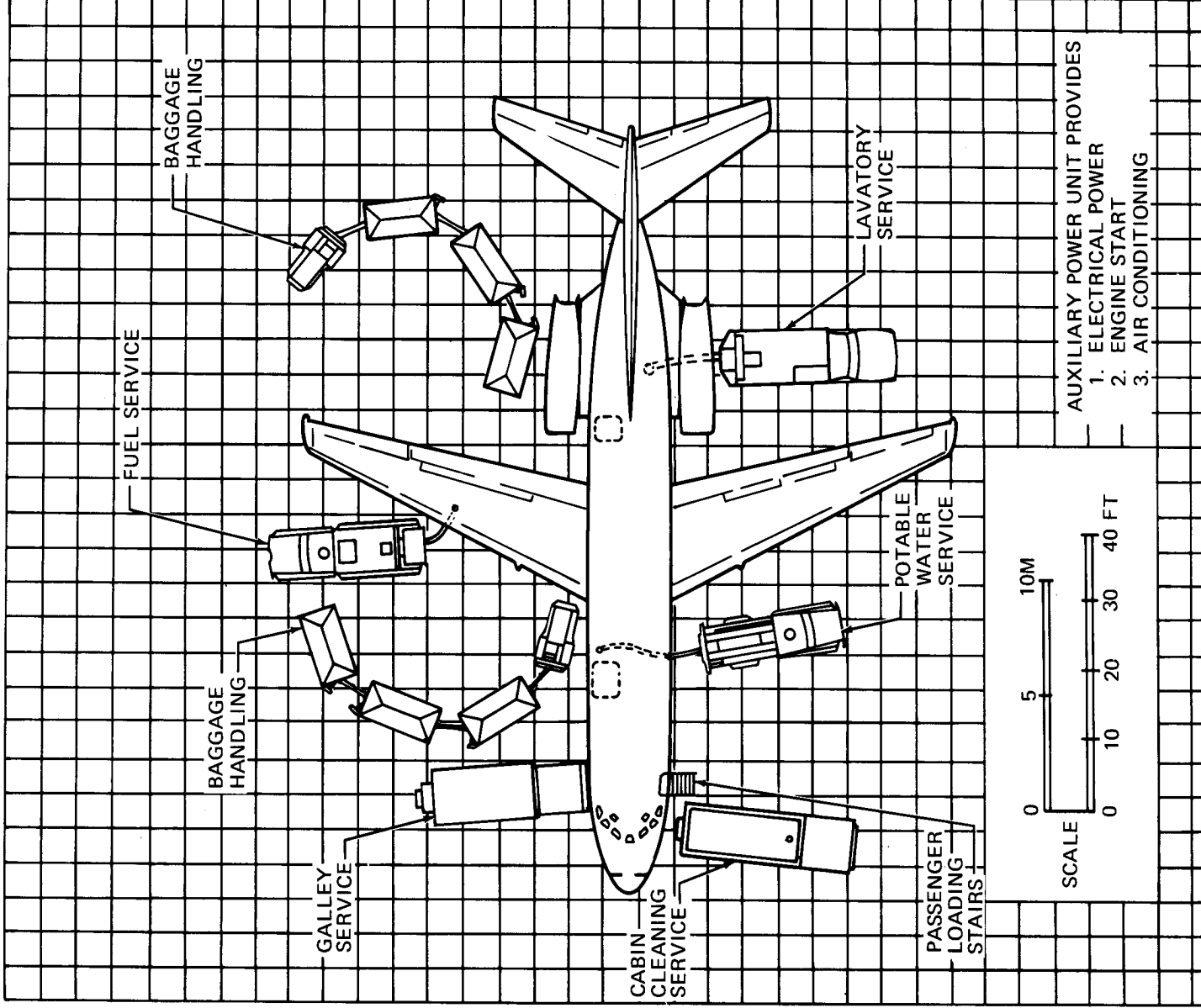

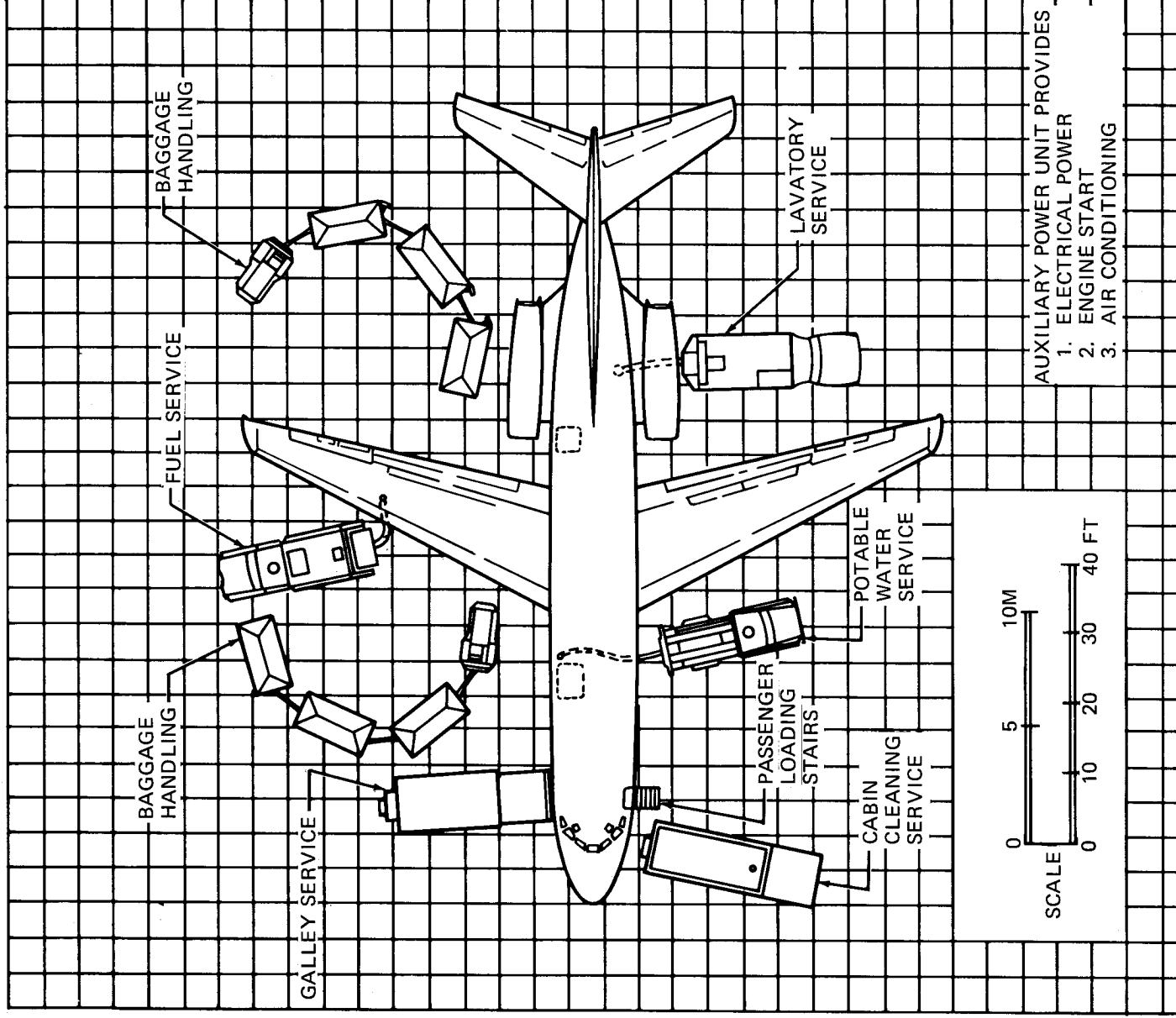

5.1 AIRPLANE SERVICING ARRANGEMENT (TYPICAL)
MODEL DC-9-21

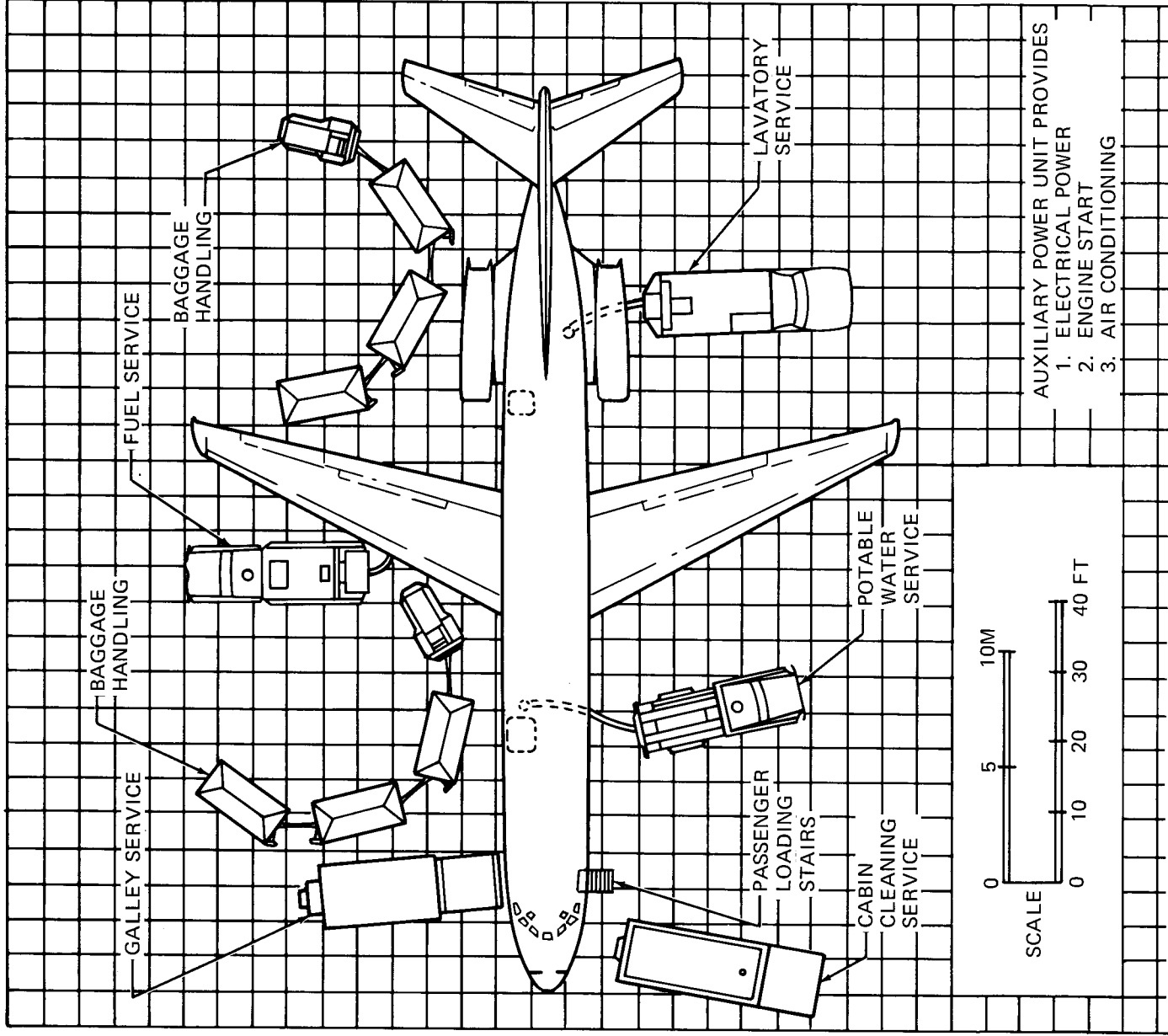

5.1 AIRPLANE SERVICING ARRANGEMENT (TYPICAL) MODEL DC-9-32

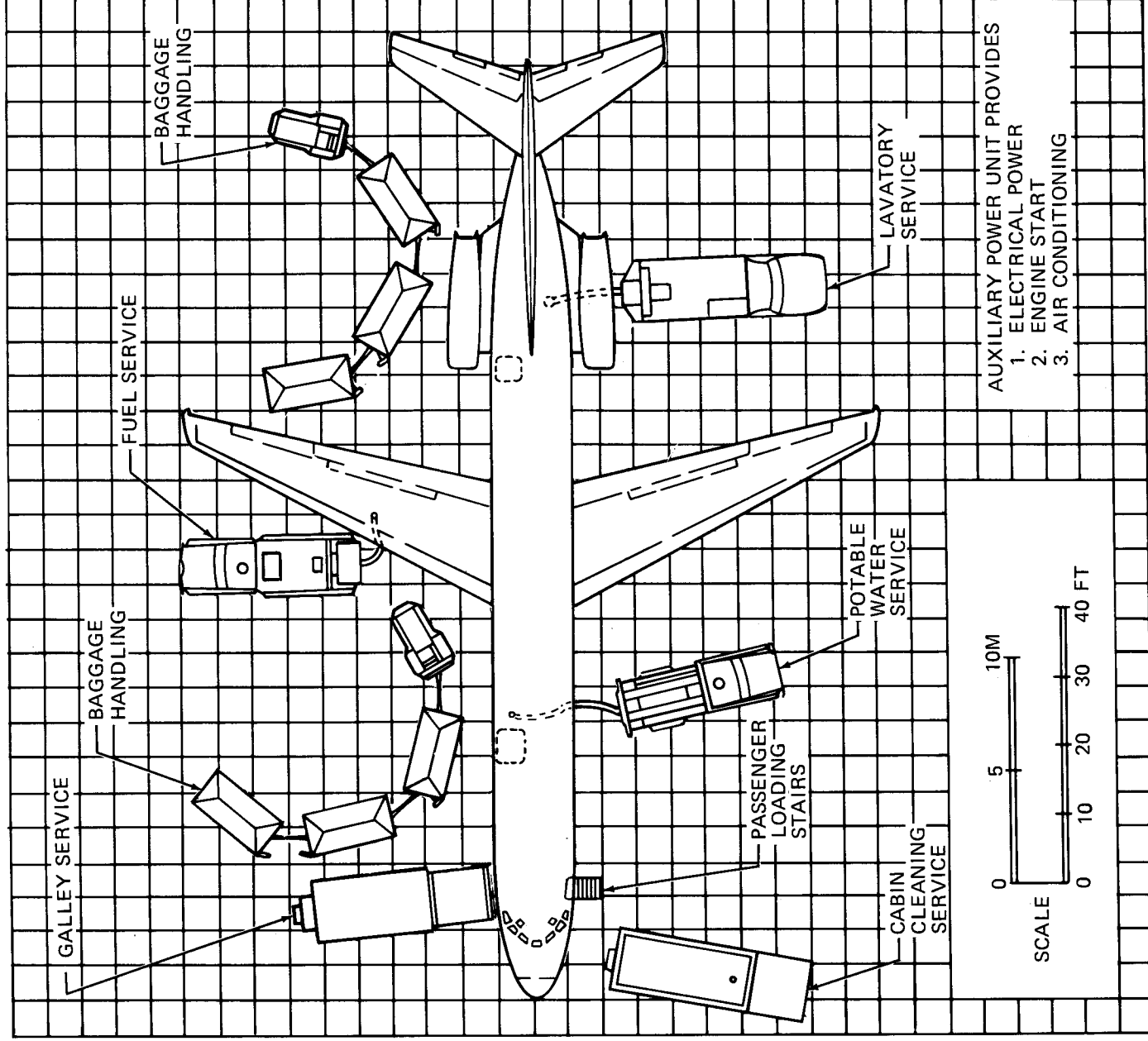

5.1 AIRPLANE SERVICING ARRANGEMENT (TYPICAL) MODEL DC-9-41

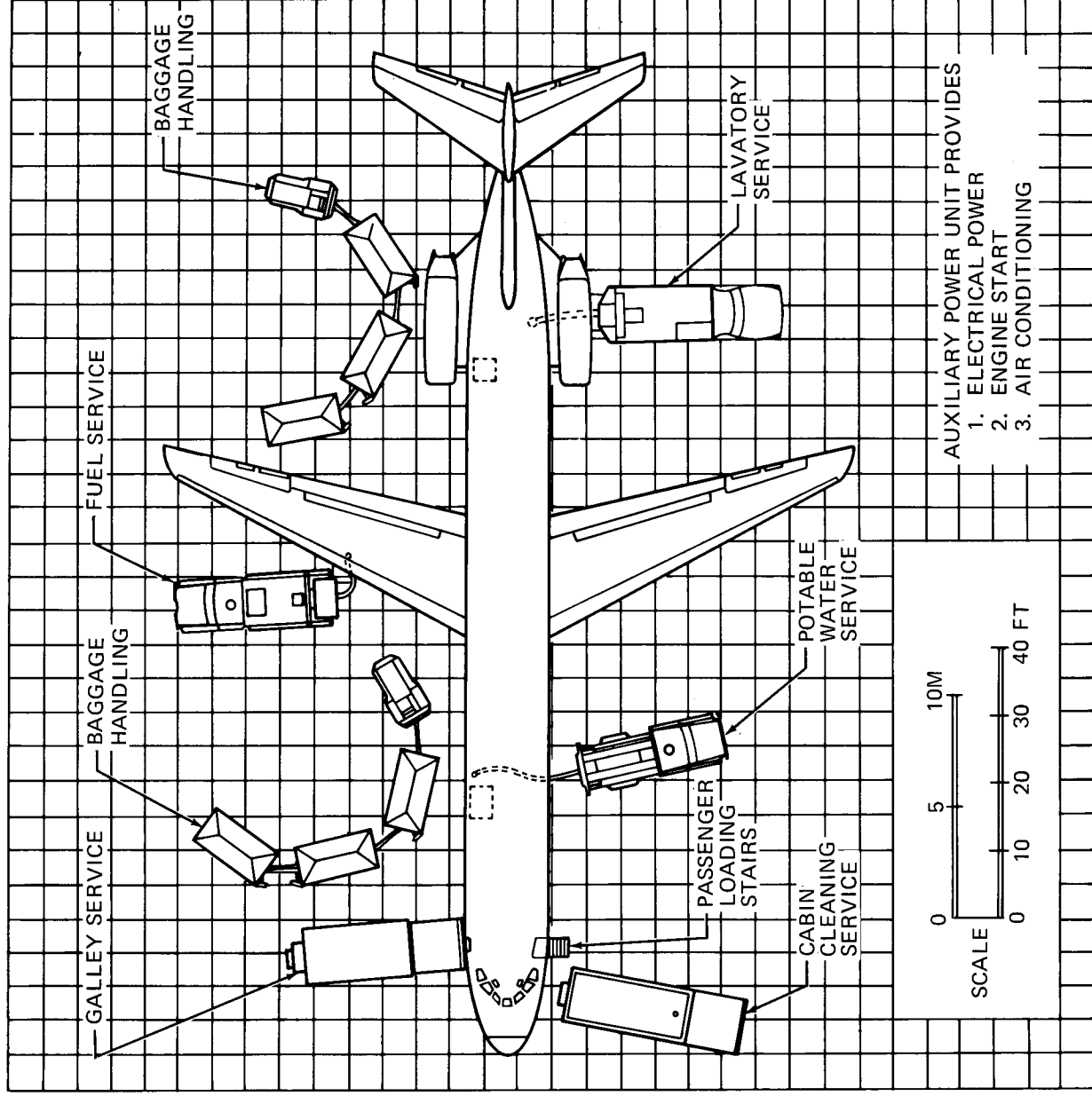

5.1 AIRPLANE SERVICING ARRANGEMENT (TYPICAL) MODEL DC-9-51

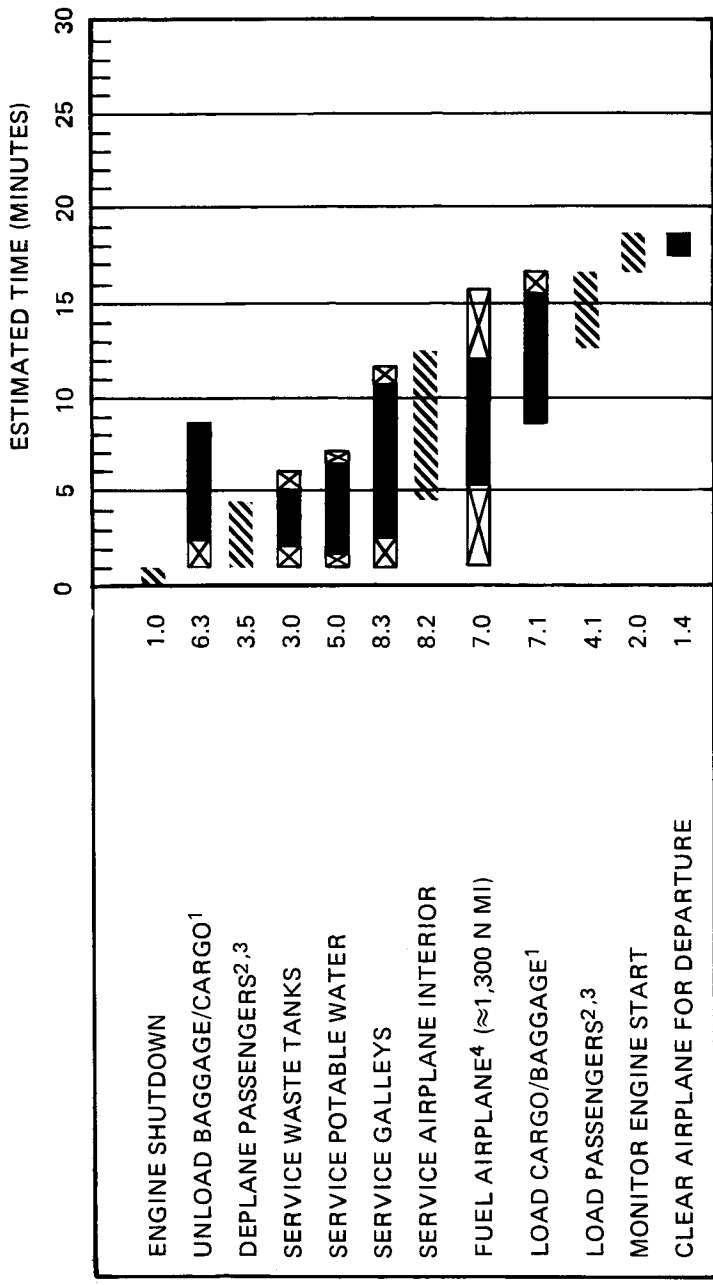

Critical time path
 Vehicle movement

- Tourist class configuration with 90 passengers
- 100-percent load factor
- Two baggage/cargo crews

¹Time available for 680 lb of bulk cargo

²Passenger enplane and deplane via front airstair and ventral stairs

³An additional 2.0 minutes required for bridge operations

⁴Additional time required for fueling if auxiliary tanks or 35 PSIG system pressure are used.

NOTE: ONBOARD APU OPERATIONAL FOR AIR CONDITIONING, ENGINE START, AND ELECTRICAL POWER. THIS DATA IS PROVIDED TO ILLUSTRATE THE GENERAL SCOPE AND TYPES OF TASKS INVOLVED IN TERMINAL OPERATIONS. VARYING AIRLINE PRACTICES AND OPERATING CIRCUMSTANCES THROUGHOUT THE WORLD WILL RESULT IN DIFFERENT SEQUENCES AND TIME INTERVALS TO ACCOMPLISH THE TASKS SHOWN.

BECAUSE OF THIS, GROUND OPERATIONS REQUIREMENTS SHOULD BE COORDINATED WITH THE USING AIRLINES PRIOR TO RAMP PLANNING.

5.2 TERMINAL OPERATIONS TURNAROUND STATION MODEL DC-9-15 AND 21

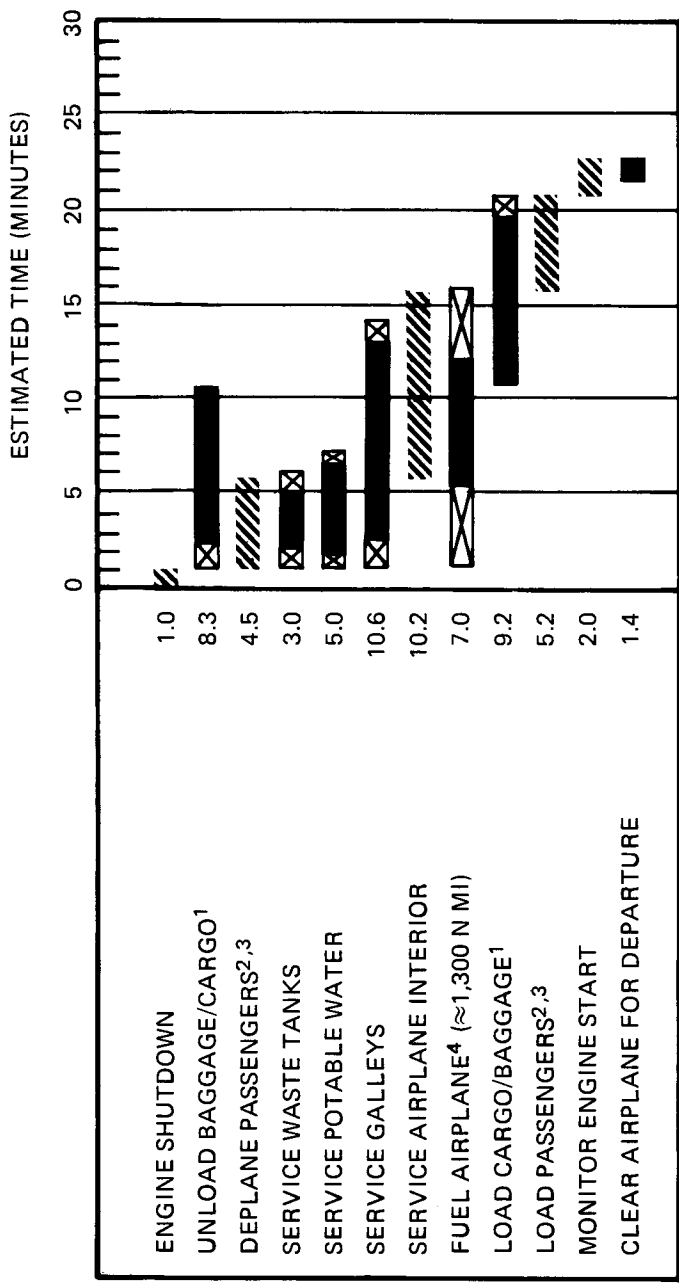

Critical time path
 Vehicle movement

- Tourist class configuration with 115 passengers
- 100-percent load factor
- Two baggage/cargo crews

¹ Time available for 1,090 lb of bulk cargo
² Passenger enplane and deplane via front airstair and ventral stairs
³ An additional 2.6 minutes required for bridge operations
⁴ Additional time required for fueling if auxiliary tanks or PSIG system pressure are used.

NOTE: ONBOARD APU OPERATIONAL FOR AIR CONDITIONING, ENGINE START, AND ELECTRICAL POWER. THIS DATA IS PROVIDED TO ILLUSTRATE THE GENERAL SCOPE AND TYPES OF TASKS INVOLVED IN TERMINAL OPERATIONS. VARYING AIRLINE PRACTICES AND OPERATING CIRCUMSTANCES THROUGHOUT THE WORLD WILL RESULT IN DIFFERENT SEQUENCES AND TIME INTERVALS TO ACCOMPLISH THE TASKS SHOWN. BECAUSE OF THIS, GROUND OPERATIONS REQUIREMENTS SHOULD BE COORDINATED WITH THE USING AIRLINES PRIOR TO RAMP PLANNING.

5.2 TERMINAL OPERATIONS TURNAROUND STATION MODEL DC-9-32

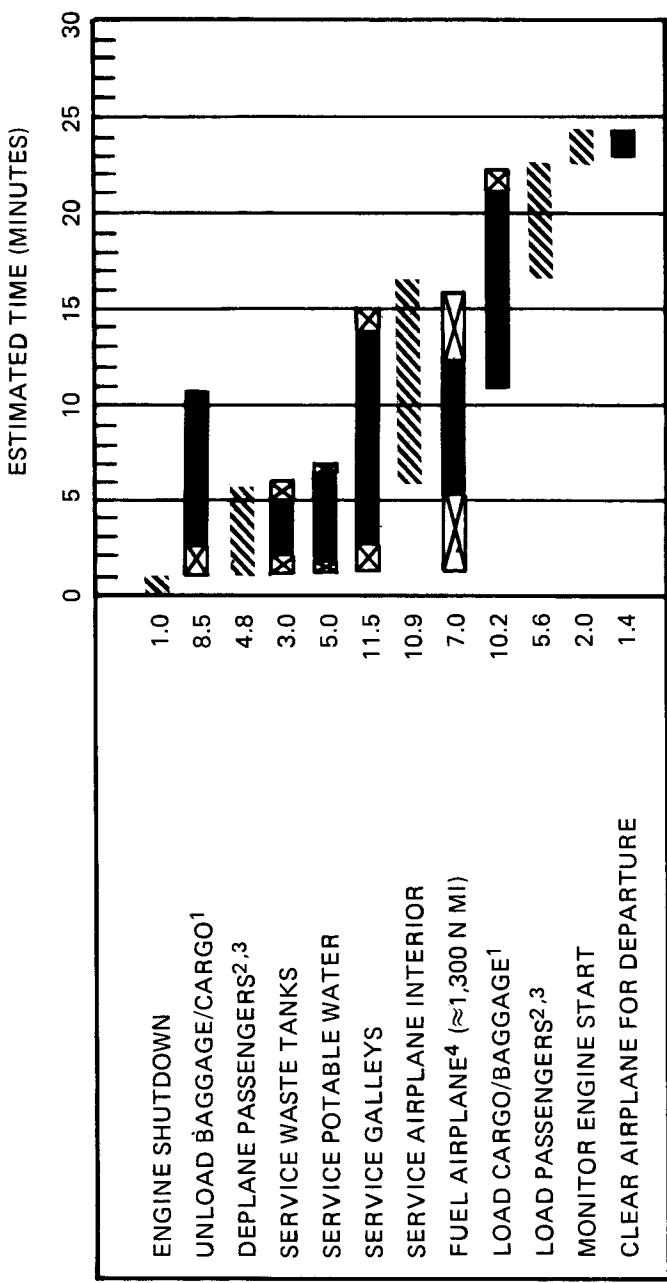

Critical time path
 Vehicle movement

- Tourist class configuration with 125 passengers
- 100-percent load factor
- Two baggage/cargo crews

¹ Time available for 1,060 lb of bulk cargo
² Passenger enplane and deplane via front airstair and ventral stairs
³ An additional 2.9 minutes required for bridge operations
⁴ Additional time required for fueling if auxiliary tanks or PSIG system pressure are used.

NOTE: ONBOARD APU OPERATIONAL FOR AIR CONDITIONING, ENGINE START, AND ELECTRICAL POWER. THIS DATA IS PROVIDED TO ILLUSTRATE THE GENERAL SCOPE AND TYPES OF TASKS INVOLVED IN TERMINAL OPERATIONS. VARYING AIRLINE PRACTICES AND OPERATING CIRCUMSTANCES THROUGHOUT THE WORLD WILL RESULT IN DIFFERENT SEQUENCES AND TIME INTERVALS TO ACCOMPLISH THE TASKS SHOWN. BECAUSE OF THIS, GROUND OPERATIONS REQUIREMENTS SHOULD BE COORDINATED WITH THE USING AIRLINES PRIOR TO RAMP PLANNING.

5.2 TERMINAL OPERATIONS TURNAROUND STATION MODEL DC-9-41

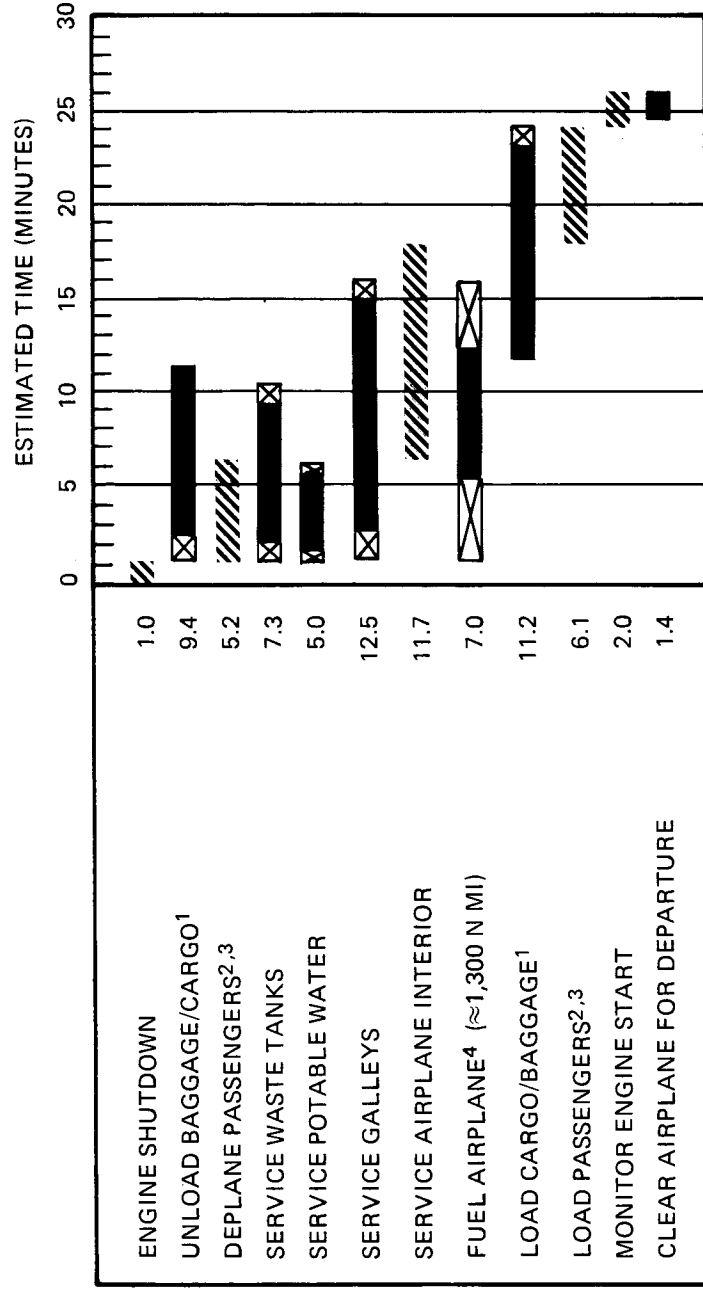

Critical time path

Vehicle movement

- Tourist class configuration with 135 passengers
- 100-percent load factor
- Two baggage/cargo crews

¹Time available for 1,140 lb of bulk cargo

²Passenger enplane and deplane via front airstair and ventral stairs

³An additional 3.1 minutes required for bridge operations

⁴Additional time required for fueling if auxiliary tanks or 35 PSIG system pressure are used.

NOTE: ONBOARD APU OPERATIONAL FOR AIR CONDITIONING, ENGINE START, AND ELECTRICAL POWER.

THIS DATA IS PROVIDED TO ILLUSTRATE THE GENERAL SCOPE AND TYPES OF TASKS INVOLVED IN TERMINAL OPERATIONS. VARYING AIRLINE PRACTICES AND OPERATING CIRCUMSTANCES THROUGHOUT THE WORLD WILL RESULT IN DIFFERENT SEQUENCES AND TIME INTERVALS TO ACCOMPLISH THE TASKS SHOWN.

BECAUSE OF THIS, GROUND OPERATIONS REQUIREMENTS SHOULD BE COORDINATED WITH THE USING AIRLINES PRIOR TO RAMP PLANNING.

5.2 TERMINAL OPERATIONS TURNAROUND STATION MODEL DC-9-51

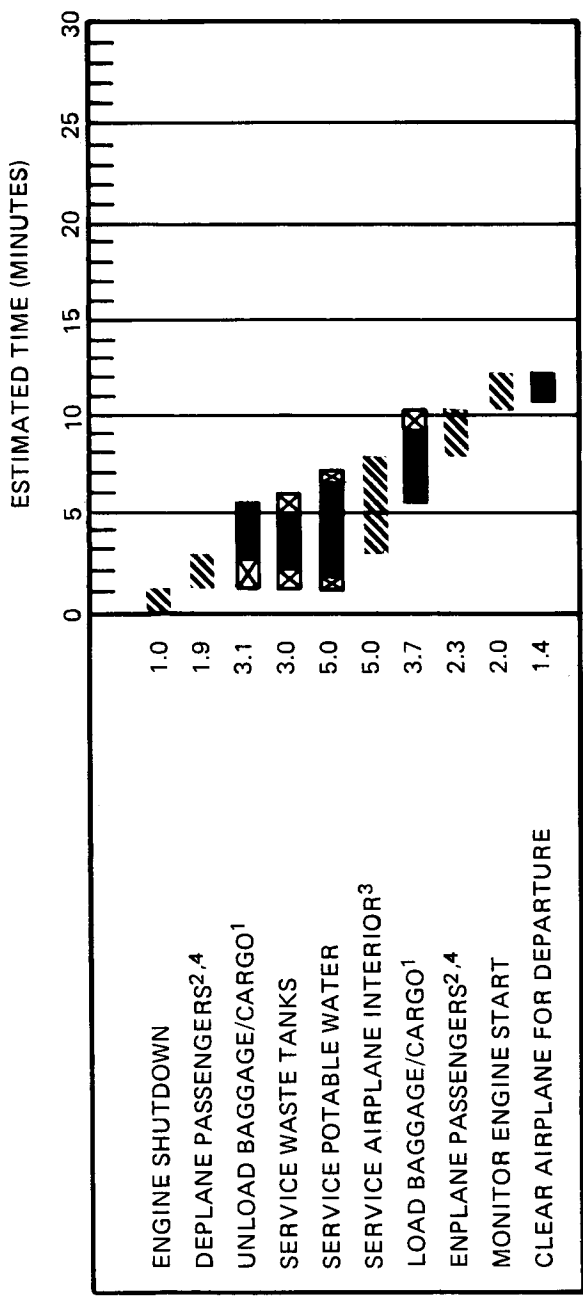

Critical time path

Vehicle movement

- 55 percent exchange of passengers
- Tourist class configuration with 50 passengers
- Two baggage/cargo crews

¹ Time available for 440 lb of bulk cargo

² Passenger enplane and deplane via front airstair and ventral stairs

³ Cabin tidied by cabin attendant

⁴ An additional 1.1 minutes required for bridge operations

NOTE: ONBOARD APU OPERATIONAL FOR AIR CONDITIONING, ENGINE START, AND ELECTRICAL POWER. THIS DATA IS PROVIDED TO ILLUSTRATE THE GENERAL SCOPE AND TYPES OF TASKS INVOLVED IN TERMINAL OPERATIONS. VARYING AIRLINE PRACTICES AND OPERATING CIRCUMSTANCES THROUGHOUT THE WORLD WILL RESULT IN DIFFERENT SEQUENCES AND TIME INTERVALS TO ACCOMPLISH THE TASKS SHOWN. BECAUSE OF THIS, GROUND OPERATIONS REQUIREMENTS SHOULD BE COORDINATED WITH THE USING AIRLINES PRIOR TO RAMP PLANNING.

5.3 TERMINAL OPERATIONS, EN ROUTE STATION MODEL DC-9-15 AND -21

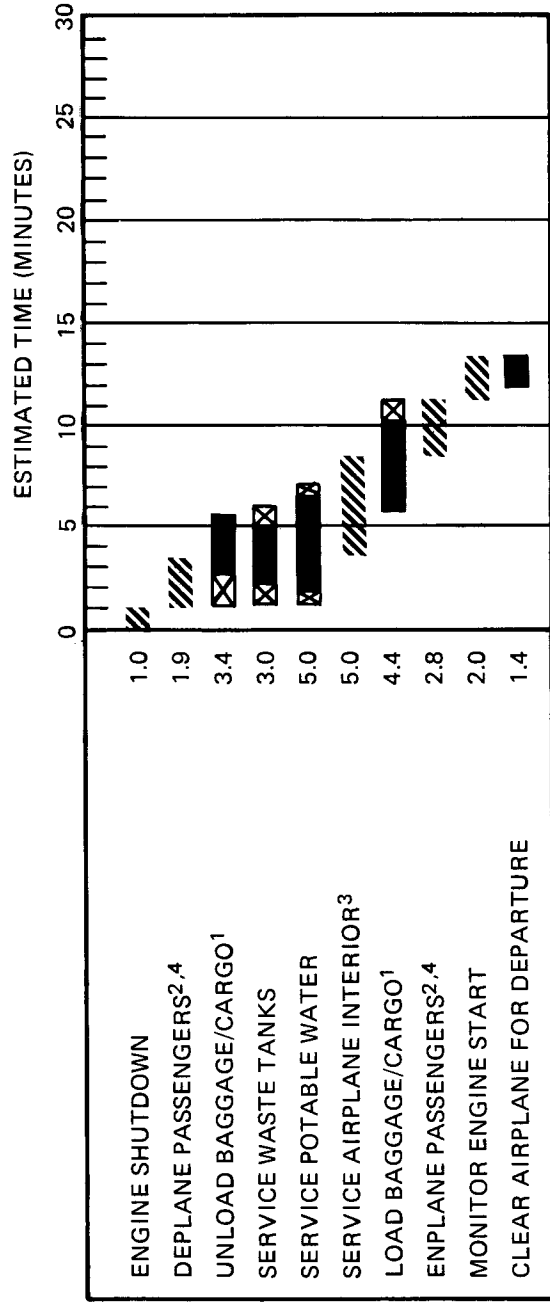

Critical time path

Vehicle movement

• 55 percent exchange of passengers

• Tourist class configuration with 63 passengers

• Two baggage/cargo crews

¹Time available for 460 lb of bulk cargo

²Passenger enplane and deplane via front airstair and ventral stairs

³Cabin tidied by cabin attendant

⁴An additional 1.5 minutes required for bridge operations

NOTE: ONBOARD APU OPERATIONAL FOR AIR CONDITIONING, ENGINE START, AND ELECTRICAL POWER.

THIS DATA IS PROVIDED TO ILLUSTRATE THE GENERAL SCOPE AND TYPES OF TASKS INVOLVED IN TERMINAL OPERATIONS. VARYING AIRLINE PRACTICES AND OPERATING CIRCUMSTANCES THROUGHOUT THE WORLD WILL RESULT IN DIFFERENT SEQUENCES AND TIME INTERVALS TO ACCOMPLISH THE TASKS SHOWN.

BECAUSE OF THIS, GROUND OPERATIONS REQUIREMENTS SHOULD BE COORDINATED WITH THE USING AIRLINES PRIOR TO RAMP PLANNING.

5.3 TERMINAL OPERATIONS, EN ROUTE STATION MODEL DC-9-32

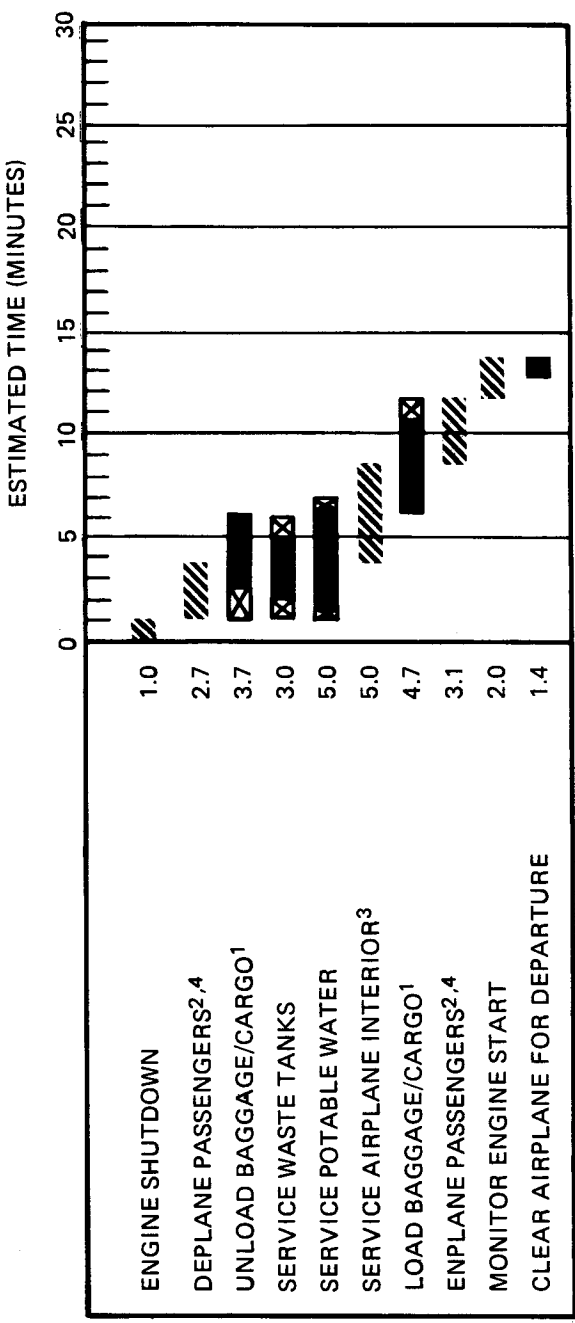

 Critical time path
 Vehicle movement

- 55 percent exchange of passengers
- Tourist class configuration with 69 passengers
- Two baggage/cargo crews

¹Time available for 520 lb of bulk cargo

²Passenger enplane and deplane via front airstair and ventral stairs

³Cabin tidied by cabin attendants

⁴An additional 1.6 minutes required for bridge operations

NOTE: ONBOARD APU OPERATIONAL FOR AIR CONDITIONING, ENGINE START, AND ELECTRICAL POWER.

THIS DATA IS PROVIDED TO ILLUSTRATE THE GENERAL SCOPE AND TYPES OF TASKS INVOLVED IN TERMINAL OPERATIONS. VARYING AIRLINE PRACTICES AND OPERATING CIRCUMSTANCES THROUGHOUT THE WORLD WILL RESULT IN DIFFERENT SEQUENCES AND TIME INTERVALS TO ACCOMPLISH THE TASKS SHOWN.

BECAUSE OF THIS, GROUND OPERATIONS REQUIREMENTS SHOULD BE COORDINATED WITH THE USING AIRLINES PRIOR TO RAMP PLANNING.

5.3 TERMINAL OPERATIONS, EN ROUTE STATION MODEL DC-9-41

ESTIMATED TIME (MINUTES)

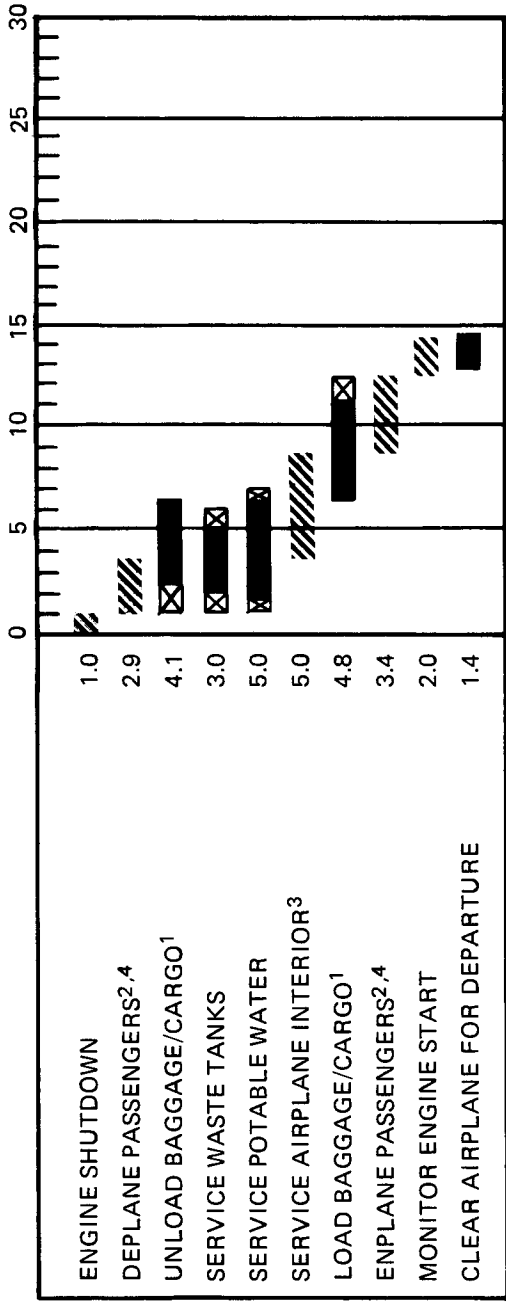

/// Critical time path

⊠ Vehicle movement

● 55 percent exchange of passengers

● Tourist class configuration with 76 passengers

● Two baggage/cargo crews

¹Time available for 530 lb of bulk cargo

²Passenger enplane and deplane via front airstair and ventral stairs

³Cabin tidied by cabin attendant

⁴An additional 1.8 minutes required for bridge operations

NOTE: ONBOARD APU OPERATIONAL FOR AIR CONDITIONING, ENGINE START, AND ELECTRICAL POWER.

THIS DATA IS PROVIDED TO ILLUSTRATE THE GENERAL SCOPE AND TYPES OF TASKS INVOLVED IN TERMINAL OPERATIONS. VARYING AIRLINE PRACTICES AND OPERATING CIRCUMSTANCES THROUGHOUT THE WORLD WILL RESULT IN DIFFERENT SEQUENCES AND TIME INTERVALS TO ACCOMPLISH THE TASKS SHOWN.

BECAUSE OF THIS, GROUND OPERATIONS REQUIREMENTS SHOULD BE COORDINATED WITH THE USING AIRLINES PRIOR TO RAMP PLANNING.

5.3 TERMINAL OPERATIONS, EN ROUTE STATION MODEL DC-9-51

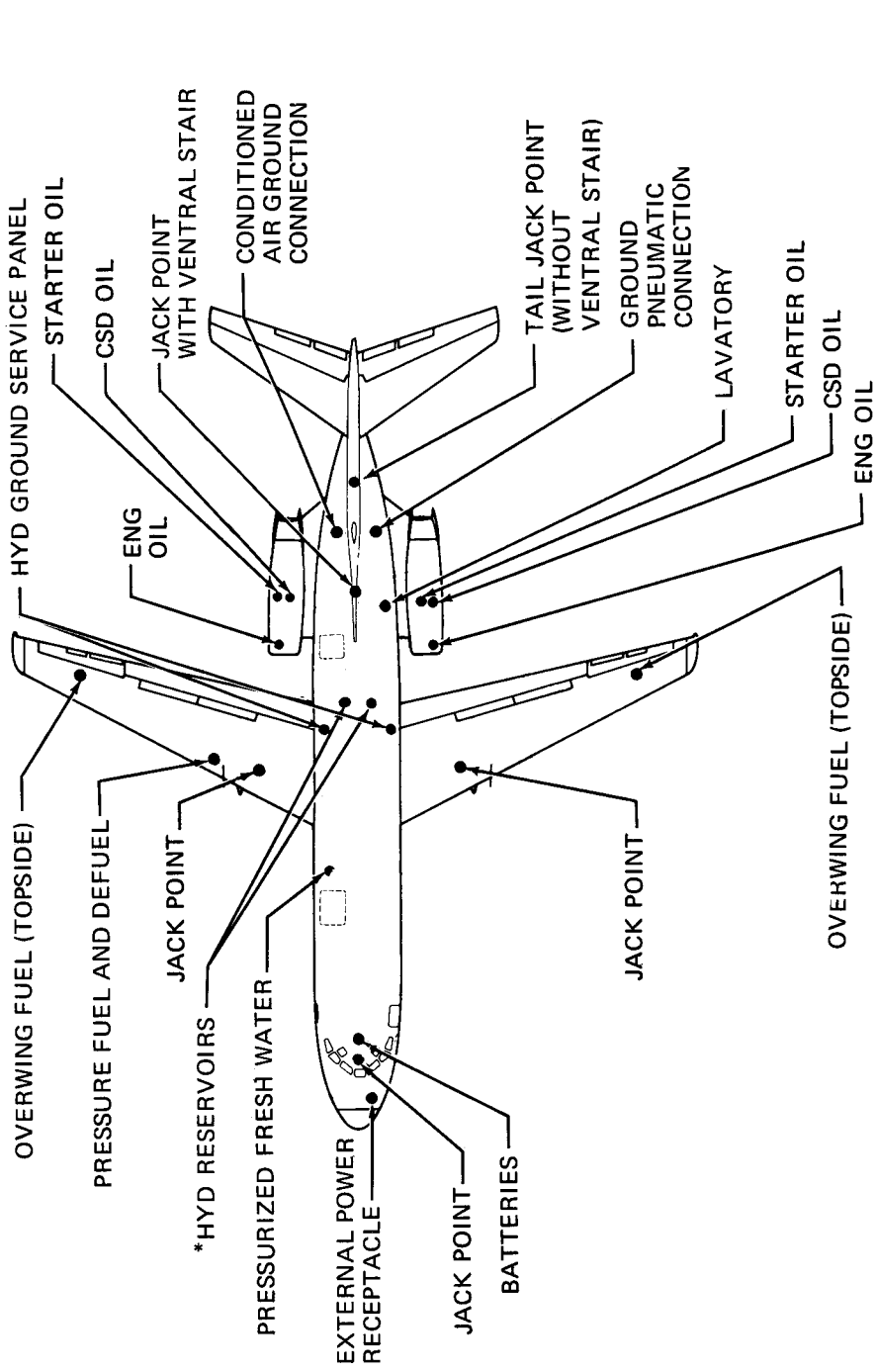

TOP VIEW

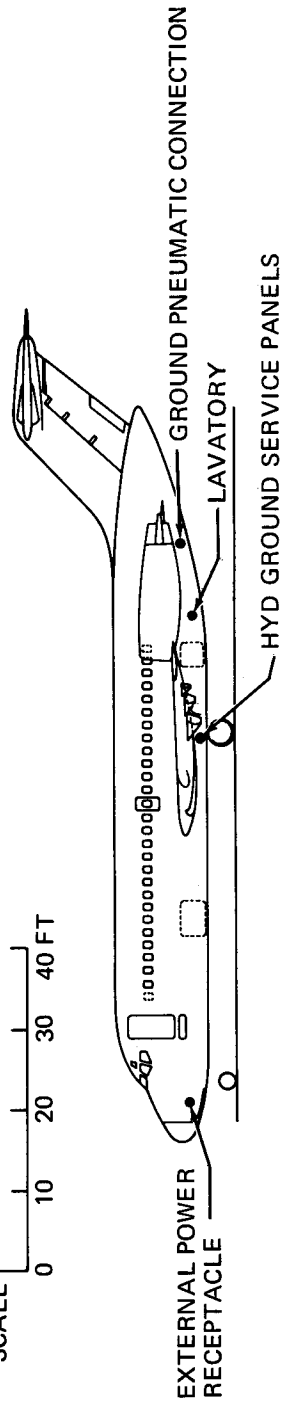
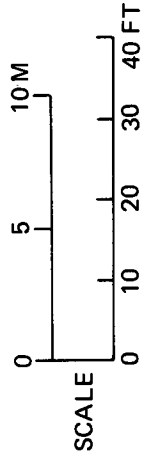

*(ACCESS THRU WHEEL WELLS)

SIDE VIEW

5.4 GROUND SERVICE CONNECTIONS MODEL DC-9-15

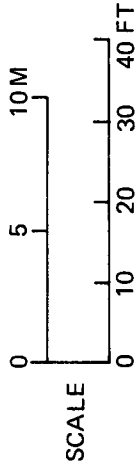
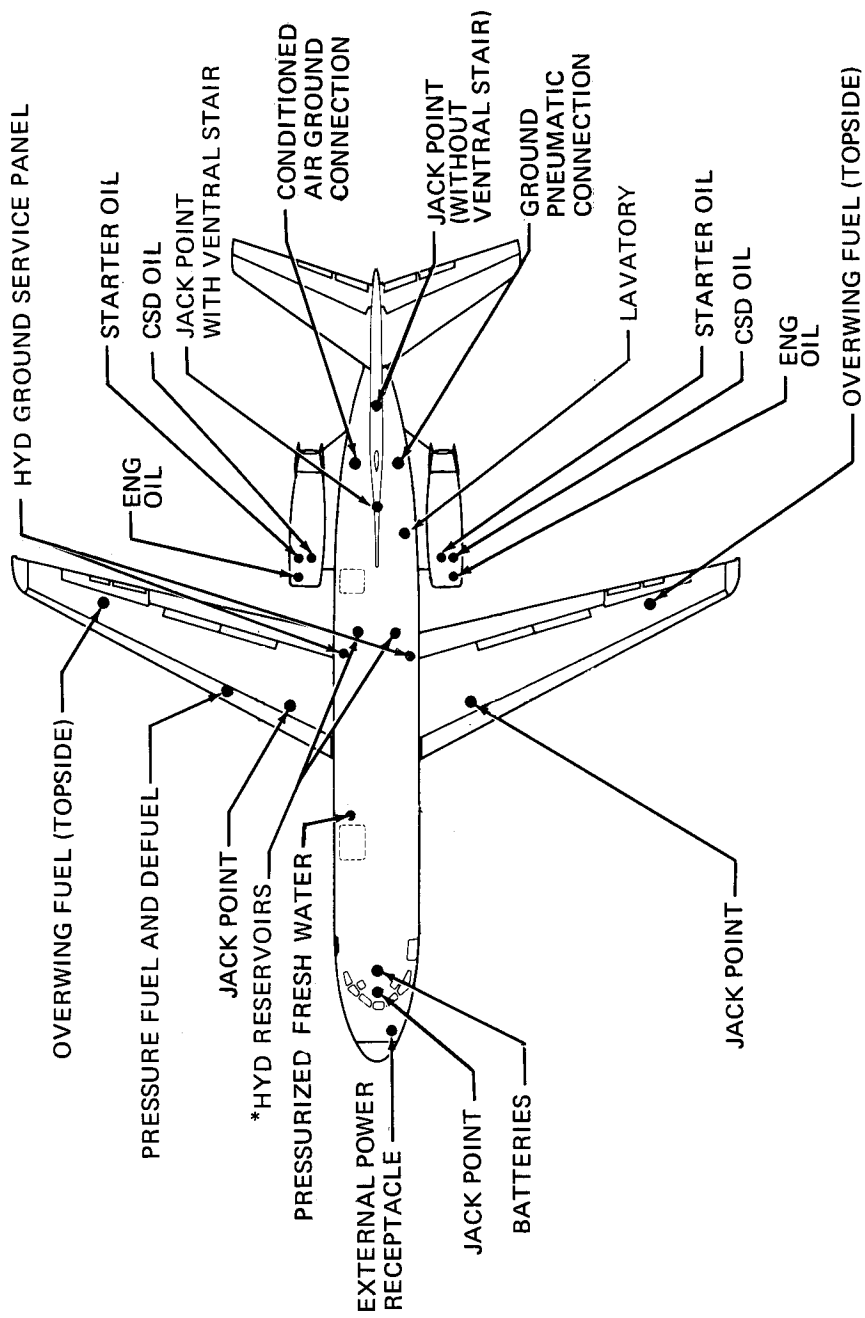

TOP VIEW

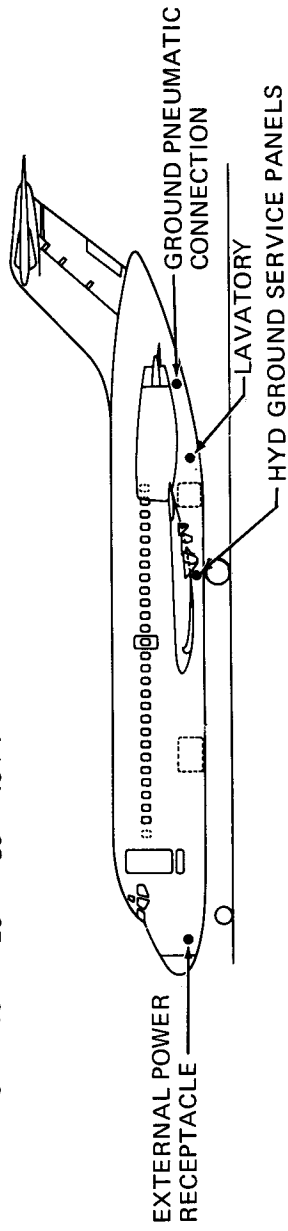

*(ACCESS THRU WHEEL WELLS)

SIDE VIEW

5.4 GROUND SERVICE CONNECTIONS MODEL DC-9-21

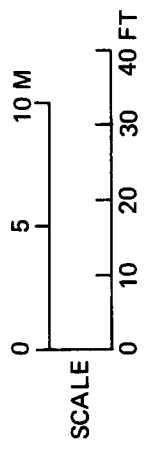
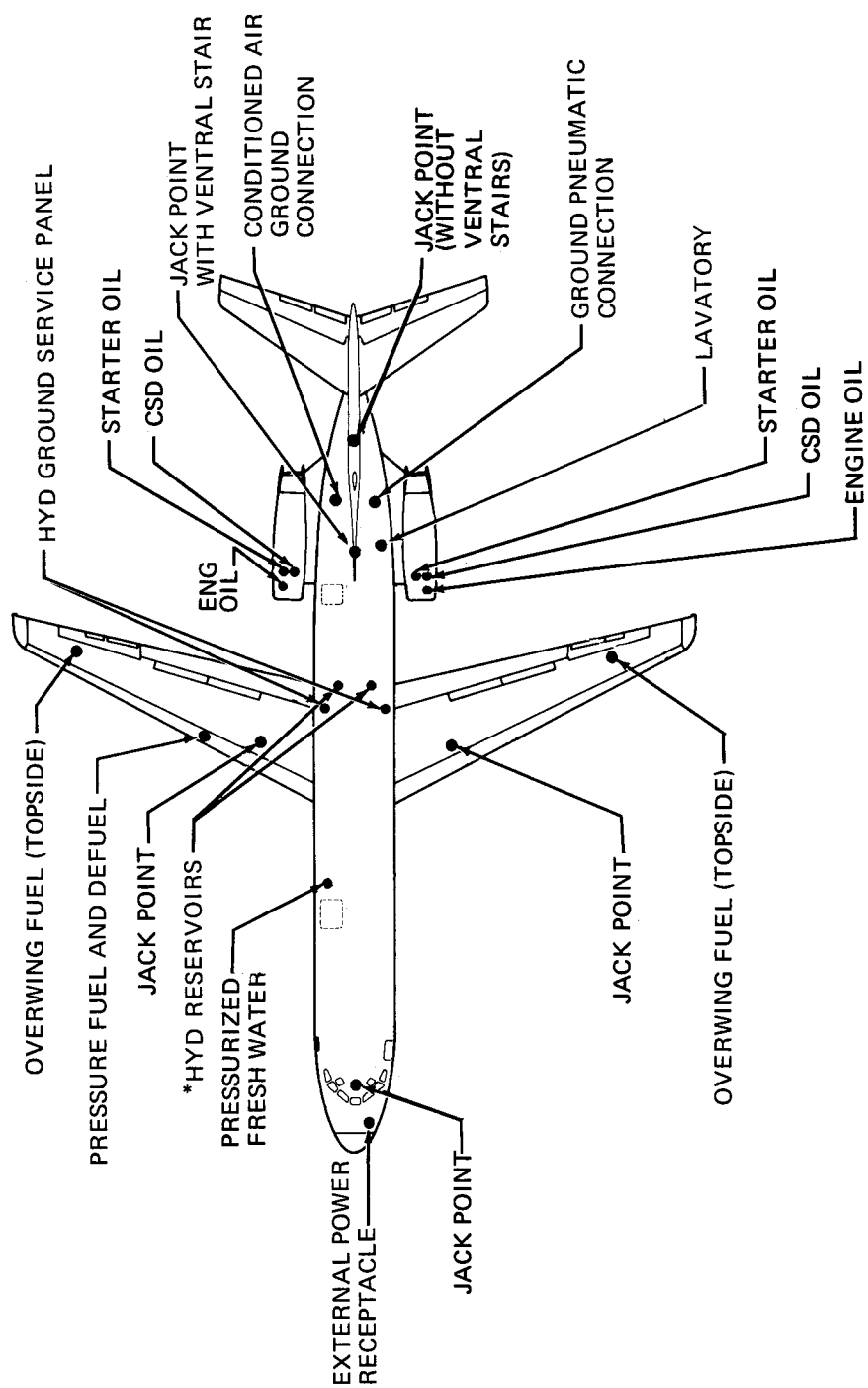

TOP VIEW

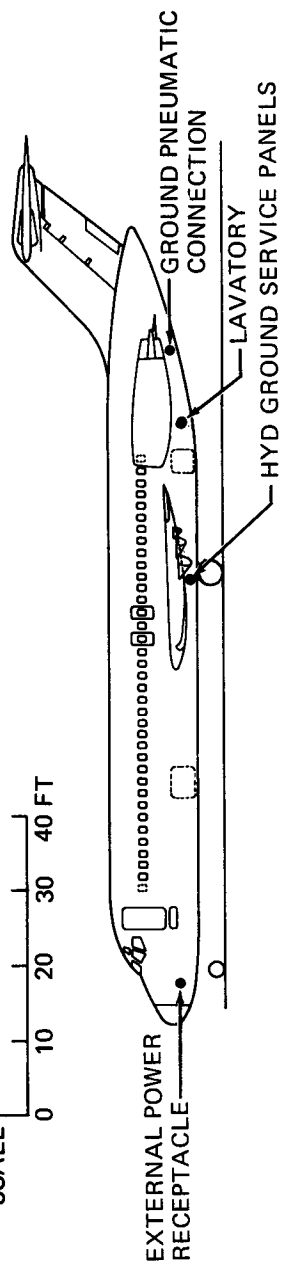

SIDE VIEW

*(ACCESS THROUGH WHEEL WELLS)

5.4 GROUND SERVICE CONNECTIONS MODEL DC-9-32

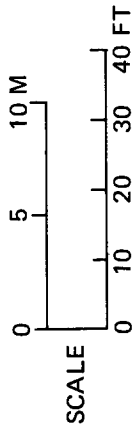
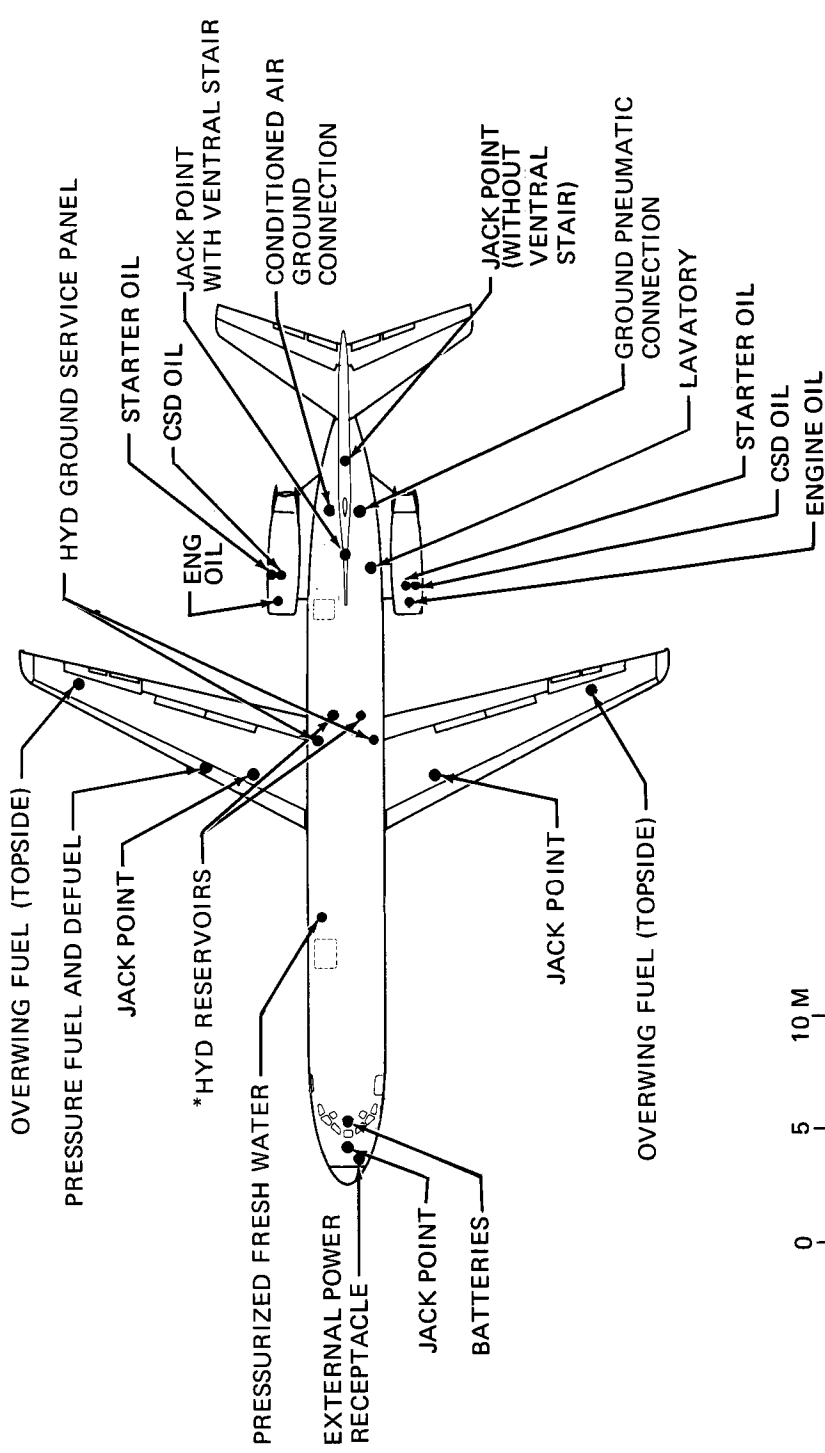

TOP VIEW

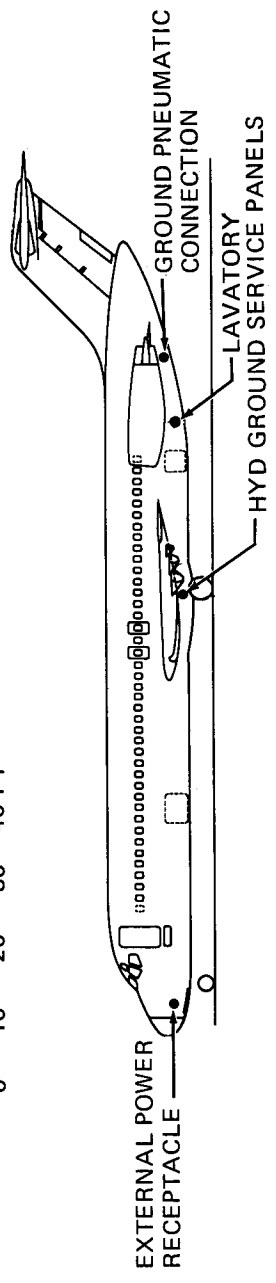

SIDE VIEW

*(ACCESS THRU WHEEL WELLS)

5.4 GROUND SERVICE CONNECTIONS MODEL DC-9-41

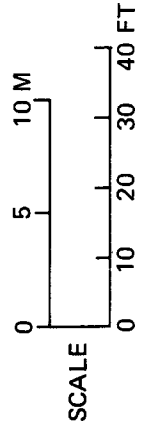
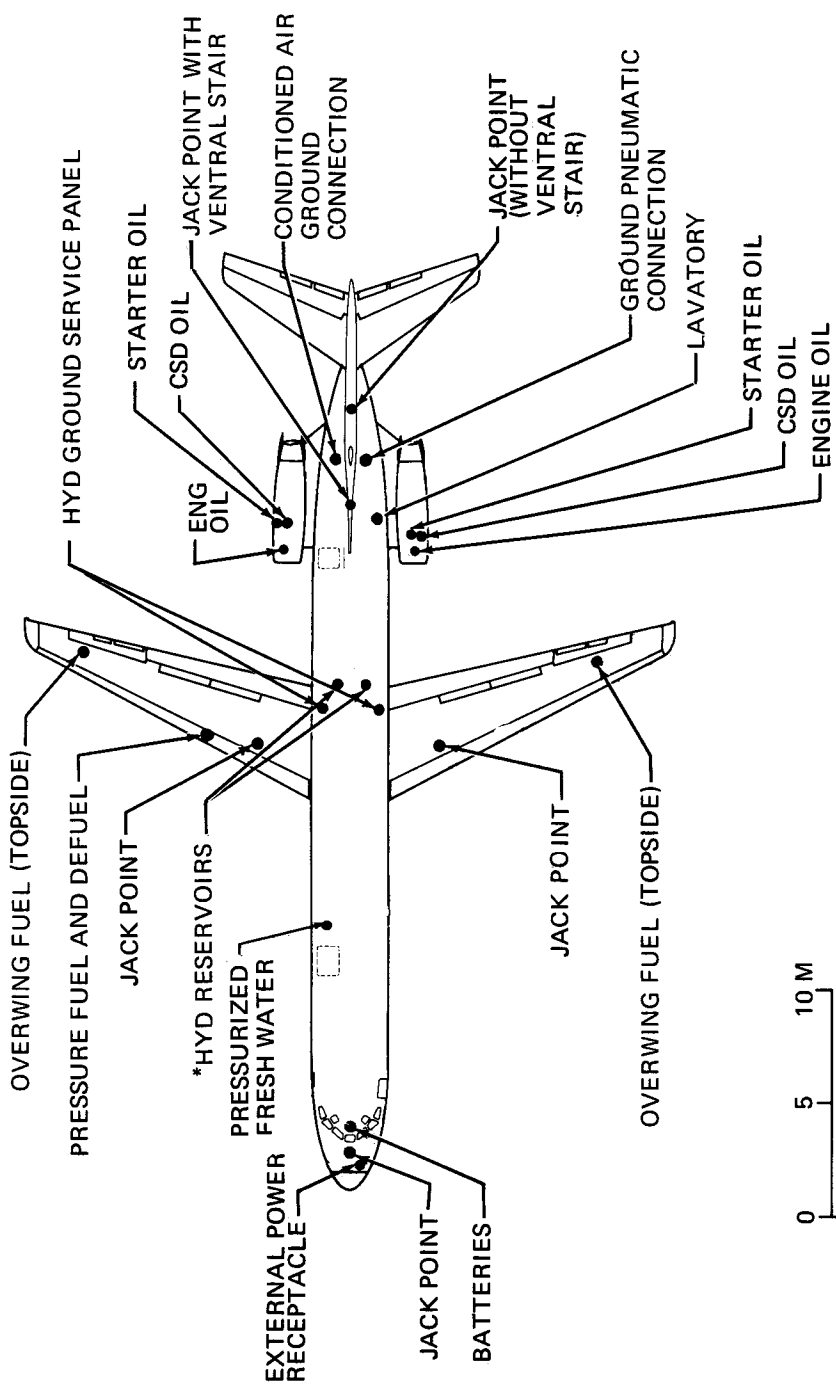

TOP VIEW

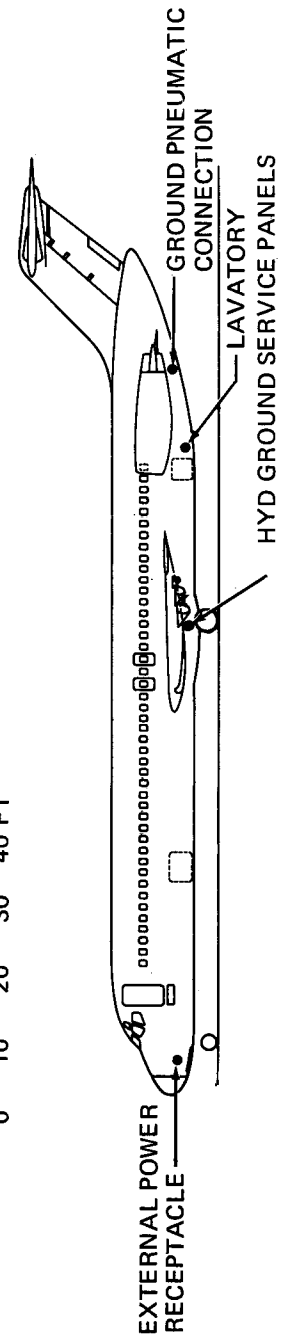

SIDE VIEW

*(ACCESS THRU WHEEL WELLS)

5.4 GROUND SERVICE CONNECTIONS MODEL DC-9-51

	DISTANCE AFT OF NOSE		DISTANCE FROM AIRPLANE CENTERLINE				HEIGHT FROM GROUND	
	FT-IN.	METERS	RIGHT SIDE		LEFT SIDE		FT-IN.	METERS
			FT-IN.	METERS	FT-IN.	METERS		
5.4.1 HYDRAULIC SYSTEM ● 2 SERVICE CONNECTIONS A. HYDRAULIC GROUND CONNECTIONS ● 8 ACCUMULATORS A. 2 BRAKE ACCUMULATORS LH AND RH B. 2 SYSTEM ACCUMULATORS LH AND RH C. 2 THRUST REVERSER ACCUMULATORS LH AND RH D. 2 ELEVATOR ACCUMULATORS RH ONLY (SYSTEM PRESSURE 3000 PSI SKYDROL 500B)	45-6	13.9	3-2	1.0	3-2	1.0	4-5	1.3
	51-10	15.8	0-4	0.1	0-4	0.1	5-9	1.8
	52-4	16.0	1-7	0.5	1-6	0.5	4-5	1.3
	69-2	21.1	4-0	1.2	4-0	1.2	5-9	1.8
	77-11	23.7	2-0	0.6	—	—	5-10	1.8
5.4.2 ELECTRICAL SYSTEM 1 GROUND SERVICE CONNECTION ● 120/208 VOLTS, 400 HZ, 3 PHASE, 4 WIRE 60 KVA CONT. AT 0.80 P.F.	7-8	2.3	—	—	4-4	1.3	5-0	1.5
5.4.3 OXYGEN SYSTEM NO GROUND SERVICE CONNECTION A. AIR CREW SYSTEM, ONE 48 CU FT CYLINDER B. PASSENGER SYSTEM, ONE 114 CU FT CYLINDER	O ₂ CYLINDERS EXCHANGED. LOCATED IN AIR CREW COMPARTMENT							
5.4.4 FUEL SYSTEM 1 GROUND SERVICE POINT ● 375 GPM (1419 LPM) AT 50 PSIG (RH WING) 3 FUEL TANKS ● TOTAL CAPACITY 3690 U.S. GAL. (13,967 LITERS) 2 OUTBOARD MAIN TANKS — 1388 GAL. EACH (5254 LITERS)	48-7	14.8	21-4	6.5	—	—	5-7	1.7

**GROUND SERVICE CONNECTION DATA
MODEL DC-9-15 AND -21**

	DISTANCE AFT OF NOSE		DISTANCE FROM AIRPLANE CENTERLINE				HEIGHT FROM GROUND	
	FT-IN.	METERS	RIGHT SIDE		LEFT SIDE		FT-IN.	METERS
			FT-IN.	METERS	FT-IN.	METERS		
5.4.4 FUEL SYSTEM (CONT) 1 CENTER WING TANK – 914 GAL (3459 LITERS) ● 2 GRAVITY FEED FILLER INLETS ● 4 SUMP DRAIN VALVES, 2 LH AND 2 RH A. CENTER WING TANK B. WING TANKS	53-3	16.2	39-4	12.0	39-4	12.0	7-4	2.2
	43-4	13.2	4-10	1.5	4-10	1.5	3-4	1.0
	47-2	14.4	5-9	1.8	5-9	1.8	4-8	1.4
5.4.5 PNEUMATIC SYSTEM ● 1 SERVICE CONNECTION FOR AIR CONDITIONING (SEE SECTION 5.6) AND ENGINE STARTING (SEE SECTION 5.5) ● 1 SERVICE CONNECTION FOR PRECONDITIONED AIR (SEE SECTION 5.7)	72-4	22.0	–	–	2-1	0.6	4-0	1.2
	72-8	22.1	2-1	0.6	–	–	4-1	1.2
5.4.6 POTABLE WATER SYSTEM ● 1 SERVICE CONNECTION AT 10 PSIG PRESSURE A. PASSENGER FORWARD POTABLE WATER SERVICE 30 U.S. GALLONS (114 LITERS) AT 6 GALLONS (23 LITERS) PER MINUTE	11-4	3.5	4-5	1.3	–	–	5-4	1.6
5.4.7 LAVATORY SYSTEM ● 1 SERVICE CONNECTION 34 U.S. GALLONS (129 LITERS) PLUS 16 U.S. GALLONS (61 LITERS) FLUSH	65-7	20.0	–	–	4-4	1.3	6-0	1.8

**GROUND SERVICE CONNECTION DATA
MODEL DC-9-15 AND -21**

	DISTANCE AFT OF NOSE		DISTANCE FROM AIRPLANE CENTERLINE				HEIGHT FROM GROUND	
	FT-IN.	METERS	RIGHT SIDE		LEFT SIDE		FT-IN.	METERS
			FT-IN.	METERS	FT-IN.	METERS		
5.4.8 ENGINE SERVICE SYSTEM								
<ul style="list-style-type: none"> ● 2 SERVICE POINTS A. OIL GRAVITY FILL-CAN SYSTEM OF 5.5 U.S. GAL. (21 LITERS), OIL TYPE SPECIFIED BY P&W SERVICE BULLETIN NO. 238 B. CONSTANT SPEED DRIVE GRAVITY FEED – CAN, REFER TO DC-9 STANDARD PRACTICE MAINTENANCE MANUAL 	65-9	20.0	7-8	2.3	10-3	3.1	7-6	2.3
	70-0	21.3	8-3	2.5	9-5	2.9	7-1	2.1

GROUND SERVICE CONNECTION DATA
MODEL DC-9-15 AND -21

	DISTANCE AFT OF NOSE		DISTANCE FROM AIRPLANE CENTERLINE				HEIGHT FROM GROUND	
	FT-IN.	METERS	RIGHT SIDE		LEFT SIDE		FT-IN.	METERS
			FT-IN.	METERS	FT-IN.	METERS		
5.4.1 HYDRAULIC SYSTEM <ul style="list-style-type: none"> ● 2 SERVICE CONNECTIONS <ul style="list-style-type: none"> A. HYDRAULIC GROUND CONNECTIONS ● 10 ACCUMULATORS <ul style="list-style-type: none"> A. 4 BRAKE ACCUMULATORS 2 LH AND 2 RH B. 2 SYSTEM ACCUMULATORS LH AND RH C. 2 THRUST REVERSER ACCUMULATORS LH AND RH D. 2 ELEVATOR ACCUMULATORS RH ONLY (SYSTEM PRESSURE 3000 PSI SKYDROL 500B) 	54-6	16.6	3-2	1.0	3-2	1.0	4-5	1.3
	61-4	18.7	0-3	0.1	0-3	0.1	5-9	1.8
	61-10	18.8	1-6	0.5	1-5	0.4	4-5	1.3
	84-1	25.6	4-0	1.2	4-0	1.2	5-9	1.8
	92-10	28.3	2.0	0.6	—	—	5-10	1.8
5.4.2 ELECTRICAL SYSTEM 1 GROUND SERVICE CONNECTION <ul style="list-style-type: none"> ● 120/208 VOLTS, 400 HZ 3 PHASE, 4 WIRE 60 KVA CONT AT 0.80 P.F. 	7-8	2.3	—	—	4-4	1.3	5-0	1.5
5.4.3 OXYGEN SYSTEM NO GROUND SERVICE CONNECTION <ul style="list-style-type: none"> A. AIR CREW SYSTEM, ONE 48 CU FT CYLINDER B. PASSENGER SYSTEM, ONE 114 CU FT CYLINDER 	O ₂ CYLINDERS EXCHANGED. LOCATED IN AIR CREW COMPARTMENT							
5.4.4 FUEL SYSTEM 1 GROUND SERVICE POINT <ul style="list-style-type: none"> ● 375 GPM (1419 LITERS PER MINUTE) AT 50 PSIG (RH WING) 3 FUEL TANKS <ul style="list-style-type: none"> ● TOTAL CAPACITY 3690 U.S. GAL (13,967 LITERS) 	58-3	17.8	21-4	6.5	—	—	5-7	1.7

**GROUND SERVICE CONNECTION DATA
MODEL DC-9-32**

	DISTANCE AFT OF NOSE		DISTANCE FROM AIRPLANE CENTERLINE				HEIGHT FROM GROUND	
	FT-IN.	METERS	RIGHT SIDE		LEFT SIDE		FT-IN.	METERS
			FT-IN.	METERS	FT-IN.	METERS		
5.4.4 FUEL SYSTEM (CONT) 2 OUTBOARD MAIN TANKS – 1388 GAL EACH (5254 LITERS) 1 CENTERWING TANK – 914 GAL (3459 LITERS) ● 2 GRAVITY FEED FILLER INLETS ● 4 SUMP DRAIN VALVES, 2 LH AND 2 RH A. CENTER WING TANK B. WING TANKS	62-8	19.1	39-4	12.0	39-4	12.0	7-4	2.2
	52-10	16.1	4-10	1.5	4-10	1.5	3-4	1.0
	56-8	17.3	5-9	1.8	5-9	1.8	4-8	1.4
5.4.5 PNEUMATIC SYSTEM ● 1 SERVICE CONNECTION FOR AIR CONDITIONING (SEE SECTION 5.6) AND ENGINE STARTING (SEE SECTION 5.5) ● 1 SERVICE CONNECTION FOR PRECONDITIONED AIR (SEE SECTION 5.7)	87-3	26.6	–	–	2-1	0.6	4-4	1.3
	87-7	26.7	2-1	0.6	–	–	4-5	1.3
5.4.6 POTABLE WATER SYSTEM ● 1 SERVICE CONNECTION AT 10 PSIG PRESSURE A. PASSENGER FORWARD POTABLE WATER SERVICE 30 U.S. GALLONS (114 LITERS) AT 6 GALLONS (23 LITERS) PER MINUTE	11-4	3.5	4-5	1.3	–	–	5-4	1.6
5.4.7 LAVATORY SYSTEM ● 1 SERVICE CONNECTION 34 U.S. GALLONS (129 LITERS) PLUS 16 U.S. GALLONS (61 LITERS) FLUSH REQUIRED AT 25-75 PSIG AND 30 GALLONS (114 LITERS) PER MINUTE	75-0	22.9	–	–	4-4	1.3	6-0	1.8

GROUND SERVICE CONNECTION DATA
MODEL DC-9-32

	DISTANCE AFT OF NOSE		DISTANCE FROM AIRPLANE CENTERLINE				HEIGHT FROM GROUND	
	FT-IN.	METERS	RIGHT SIDE		LEFT SIDE		FT-IN.	METERS
			FT-IN.	METERS	FT-IN.	METERS		
5.4.8 ENGINE SERVICE SYSTEM								
● 2 SERVICE POINTS								
A. OIL GRAVITY FILL-CAN SYSTEM OF 5.5 U.S. GAL. (21 LITERS), OIL TYPE SPECIFIED BY P&W SERVICE BULLETIN NO. 238	75-2	22.9	7-8	2.3	10-3	3.1	7-6	2.3
B. CONSTANT SPEED DRIVE GRAVITY FEED – CAN, REFER TO DC-9 STANDARD PRACTICE MAINTENANCE MANUAL	79-5	24.2	8-3	2.5	9-5	2.9	7-1	2.2

**GROUND SERVICE CONNECTION DATA
MODEL DC-9-32**

	DISTANCE AFT OF NOSE		DISTANCE FROM AIRPLANE CENTERLINE				HEIGHT FROM GROUND	
	FT-IN.	METERS	RIGHT SIDE		LEFT SIDE		FT-IN.	METERS
			FT-IN.	METERS	FT-IN.	METERS		
5.4.1 HYDRAULIC SYSTEM ● 2 SERVICE CONNECTIONS A. HYDRAULIC GROUND CONNECTIONS ● 10 ACCUMULATORS A. 4 BRAKE ACCUMULATORS 2 LH AND 2 RH B. 2 SYSTEM ACCUMULATORS LH AND RH C. 2 THRUST REVERSER ACCUMULATORS LH AND RH D. 2 ELEVATOR ACCUMULATORS RH ONLY (SYSTEM PRESSURE 3000 PSI SKYDROL 500B)	57-7	17.6	3-2	1.0	3-2	1.0	4-8	1.4
64-6	19.7	0-4	0.1	0-4	0.1	6-2	1.9	
65-1	19.8	1-6	0.5	1-6	0.5	4-8	1.4	
92-0	28.0	4-0	1.2	4-0	1.2	6-2	1.9	
100-9	30.7	2-0	0.6	—	—	6-3	1.9	
5.4.2 ELECTRICAL SYSTEM 1 GROUND SERVICE CONNECTION ● 120/208 VOLTS, 400 HZ, 3 PHASE, 4 WIRE 60 KVA CONT AT 0.80 P.F.	7-8	2.3	—	—	4-4	1.3	5-0	1.5
5.4.3 OXYGEN SYSTEM NO GROUND SERVICE CONNECTION A. AIR CREW SYSTEM, ONE 48 CU FT CYLINDER B. PASSENGER SYSTEM, ONE 114 CU FT CYLINDER	O ₂ CYLINDERS EXCHANGED. LOCATED IN AIR CREW COMPARTMENT							
5.4.4 FUEL SYSTEM 1 GROUND SERVICE POINT ● 375 GPM (1419 LITERS PER MINUTE) AT 50 PSIG (RH WING) 3 FUEL TANKS ● TOTAL CAPACITY 3690 U.S. GAL (13,967 LITERS) 2 OUTBOARD MAIN TANKS 1388 GAL EACH (5254 LITERS)	61-5	18.7	21-4	6.5	—	—	5-11	1.8

**GROUND SERVICE CONNECTION DATA
MODEL DC-9-41**

	DISTANCE AFT OF NOSE		DISTANCE FROM AIRPLANE CENTERLINE				HEIGHT FROM GROUND	
	FT-IN.	METERS	RIGHT SIDE		LEFT SIDE		FT-IN.	METERS
			FT-IN.	METERS	FT-IN.	METERS		
5.4.4 FUEL SYSTEM (CONT) 1 CENTER WING TANK – 914 GALLONS (3459 LITERS) ● 2 GRAVITY FEED FILLER INLETS ● 4 SUMP DRAIN VALVES, 2 LH AND 2 RH A. CENTER WING TANK B. WING TANKS	65-9	20.0	39-4	12.0	39-4	12.0	7-7	2.3
	56-0	17.1	4-10	1.5	4-10	1.5	3-4	1.0
	59-10	18.2	5-9	1.8	5-9	1.8	4-8	1.4
5.4.5 PNEUMATIC SYSTEM ● 1 SERVICE CONNECTION FOR AIR CONDITIONING (SEE SECTION 5.6) AND ENGINE STARTING (SEE SECTION 5.5) ● 1 SERVICE CONNECTION FOR PRECONDITIONED AIR (SEE SECTION 5.7)	93-7	28.5	–	–	2-1	0.6	4-7	1.4
	93-11	28.6	2-1	0.6	–	–	4-8	1.4
5.4.6 POTABLE WATER SYSTEM ● 1 SERVICE CONNECTION AT 10 PSIG PRESSURE A. PASSENGER FORWARD POTABLE WATER SERVICE 30 U.S. GALLONS (114 LITERS) AT 6 GALLONS (23 LITERS) PER MINUTE	11-4	3.5	4-5	1.3	–	–	5-5	1.7
5.4.7 LAVATORY SYSTEM ● 1 SERVICE CONNECTION 34 U.S. GALLONS (129 LITERS) PLUS 16 U.S. GALLONS (61 LITERS) FLUSH REQUIRED AT 25-75 PSIG AND 30 GALLONS (114 LITERS) PER MINUTE	77-5	23.6	–	–	4-5	1.3	6-0	1.8

GROUND SERVICE CONNECTION DATA
MODEL DC-9-41

	DISTANCE AFT OF NOSE		DISTANCE FROM AIRPLANE CENTERLINE				HEIGHT FROM GROUND	
	FT-IN.	METERS	RIGHT SIDE		LEFT SIDE		FT-IN.	METERS
			FT-IN.	METERS	FT-IN.	METERS		
5.4.8 ENGINE SERVICE SYSTEM								
● 2 SERVICE POINTS								
A. OIL GRAVITY FILL-CAN SYSTEM OF 55 U.S. GAL (21 LITERS), OIL TYPE SPECIFIED BY P&W SERVICE BULLETIN NO. 238	77-7	23.6	7-8	2.3	10-3	3.1	7-6	2.3
B. CONSTANT SPEED DRIVE GRAVITY FEED CAN, REFER TO DC-9 STANDARD PRACTICE MAINTENANCE MANUAL	81-9	24.9	8-3	2.5	9-5	2.9	7-2	2.2

GROUND SERVICE CONNECTION DATA
MODEL DC-9-41

	DISTANCE AFT OF NOSE		DISTANCE FROM AIRPLANE CENTERLINE				HEIGHT FROM GROUND	
	FT-IN.	METERS	RIGHT SIDE		LEFT SIDE		FT-IN.	METERS
			FT-IN.	METERS	FT-IN.	METERS		
5.4.1 HYDRAULIC SYSTEM ● 2 SERVICE CONNECTIONS A. HYDRAULIC GROUND CONNECTIONS ● 10 ACCUMULATORS A. 4 BRAKE ACCUMULATORS 2 LH AND 2 RH B. 2 SYSTEM ACCUMULATORS LH AND RH C. 2 THRUST REVERSER ACCUMULATORS LH AND RH D. 2 ELEVATOR ACCUMULATORS RH ONLY (SYSTEM PRESSURE 3000 PSI SKYDROL 500B)	62-4	19.0	3-2	1.0	3-2	1.0	4-9	1.4
	69-3	21.1	0-4	0.1	0-4	0.1	6-3	1.9
	69-10	21.3	1-6	0.5	1-6	0.5	5-0	1.5
	91-7	30.1	4-0	1.2	4-0	1.2	6-3	2.0
	108-8	33.1	2-0	0.6	—	—	6-4	1.9
5.4.2 ELECTRICAL SYSTEM 1 GROUND SERVICE CONNECTION ● 120/208 VOLTS, 400 HZ 3 PHASE, 4 WIRE 60 KVA CONT AT 0.80 P.F.	7-8	2.3	—	—	4-4	1.3	5-0	1.5
5.4.3 OXYGEN SYSTEM NO GROUND SERVICE CONNECTION A. AIR CREW SYSTEM, ONE 48 CU FT CYLINDER B. PASSENGER SYSTEM, ONE 114 CU FT CYLINDER	O ₂ CYLINDERS EXCHANGED. LOCATED IN AIR CREW COMPARTMENT							
5.4.4 FUEL SYSTEM 1 GROUND SERVICE POINT ● 375 GPM (1419 LITERS PER MINUTE) AT 50 PSIG (RH WING) 3 FUEL TANKS ● TOTAL CAPACITY 3690 U.S. GAL (13,967 LITERS) 2 OUTBOARD MAIN TANKS – 1388 GAL EACH (5254 LITERS)	66-5	20.2	21-4	6.5	—	—	5-11	1.8

**GROUND SERVICE CONNECTION DATA
MODEL DC-9-51**

	DISTANCE AFT OF NOSE		DISTANCE FROM AIRPLANE CENTERLINE				HEIGHT FROM GROUND	
	FT-IN.	METERS	RIGHT SIDE		LEFT SIDE		FT-IN.	METERS
			FT-IN.	METERS	FT-IN.	METERS		
5.4.4 FUEL SYSTEM (CONT) 1 CENTER WING TANK – 914 GAL (3459 LITERS) ● 2 GRAVITY FEED FILLER INLETS ● 4 SUMP DRAIN VALVES, 2 LH AND 2 RH A. CENTER WING TANK B. WING TANKS	70-5	21.5	39-4	12.0	39-4	12.0	7-8	2.3
	60-9	18.5	4-10	1.5	4-10	1.5	3-4	1.0
	64-7	19.7	5-9	1.8	5-9	1.8	4-8	1.4
5.4.5 PNEUMATIC SYSTEM ● 1 SERVICE CONNECTION FOR AIR CONDITIONING (SEE SECTION 5.6) AND ENGINE STARTING (SEE SECTION 5.5) ● 1 SERVICE CONNECTION FOR PRECONDITIONED AIR (SEE SECTION 5.7)	101-6	30.9	–	–	2-1	0.6	4-9	1.4
	101-10	31.0	2.1	0.6	–	–	4-10	1.5
5.4.6 POTABLE WATER SYSTEM ● 1 SERVICE CONNECTION AT 10 PSIG PRESSURE A. PASSENGER FORWARD POTABLE WATER SERVICE 30 U.S. GALLONS (114 LITERS) AT 6 GALLONS (23 LITERS) PER MINUTE	11-4	3.5	4-5	1.3	–	–	5-6	1.7
5.4.7 LAVATORY SYSTEM ● 1 SERVICE CONNECTION 34 U.S. GALLONS (129 LITERS) PLUS 16 U.S. GALLONS (61 LITERS) FLUSH REQUIRED AT 25-75 PSIG AND 30 GALLONS (114 LITERS) PER MINUTE	85-4	26.0	–	–	4-5	1.3	6-3	1.9

GROUND SERVICE CONNECTION DATA
MODEL DC-9-51

	DISTANCE AFT OF NOSE		DISTANCE FROM AIRPLANE CENTERLINE				HEIGHT FROM GROUND	
	FT-IN.	METERS	RIGHT SIDE		LEFT SIDE		FT-IN.	METERS
			FT-IN.	METERS	FT-IN.	METERS		
5.4.8 ENGINE SERVICE SYSTEM								
● 2 SERVICE POINTS								
A. OIL GRAVITY FILL-CAN SYSTEM OF 5.5 U.S. GAL (21 LITERS), OIL TYPE SPECIFIED BY P&W SERVICE BULLETIN NO. 238	85-6	26.1	7-8	2.3	10-3	3.1	7-6	2.3
B. CONSTANT SPEED DRIVE GRAVITY FEED-CAN, REFER TO DC-9 STANDARD PRACTICE MAINTENANCE MANUAL	89-8	27.3	8-3	2.5	9-5	2.9	7-2	2.2

GROUND SERVICE CONNECTION DATA
MODEL DC-9-51

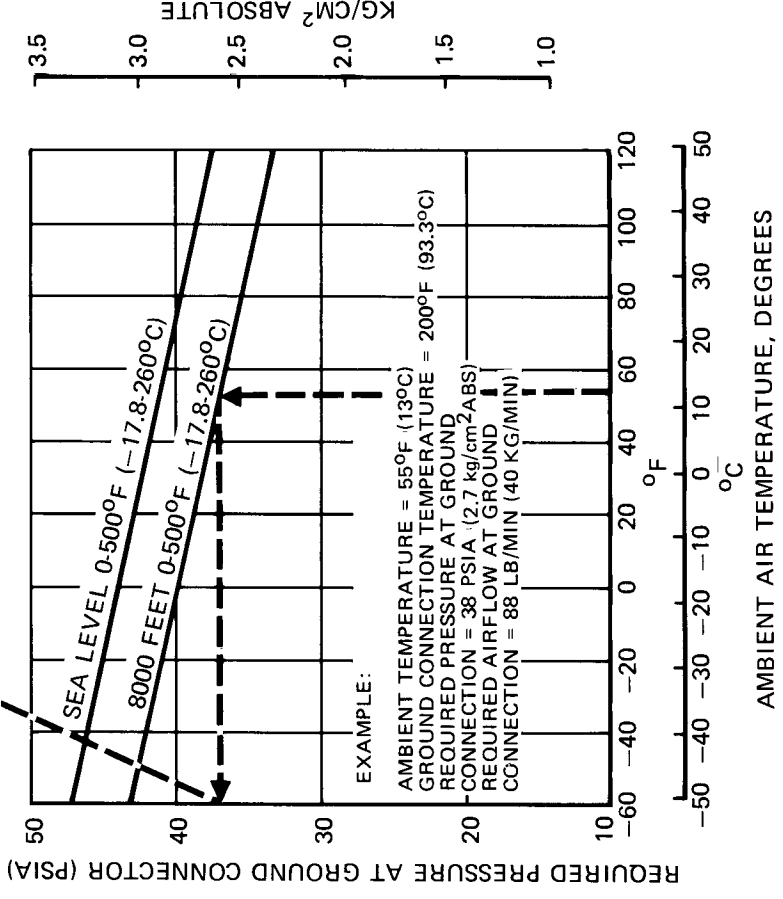
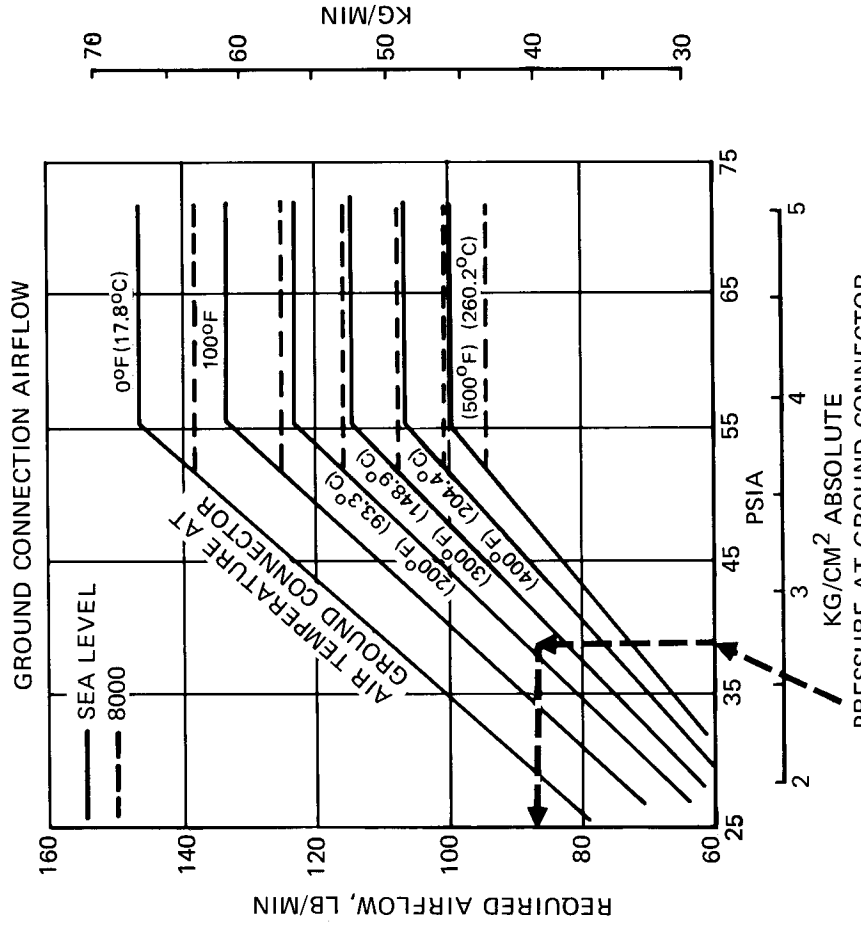

5.5 ENGINE STARTING PNEUMATIC REQUIREMENTS MODEL DC-9

INITIAL CABIN TEMP AT 0°F (-17.8°C). OUTSIDE AIR TEMP AT 0°F (-17.8°C). NO GALLEY LOAD, NO GALLEY LOAD, DULL DAY, NO LIGHTS. P = 12 TO 70 PSIG AT THE GROUND CONNECTION. TEMP AT GROUND CONNECTION = 300°F (148.9°C)

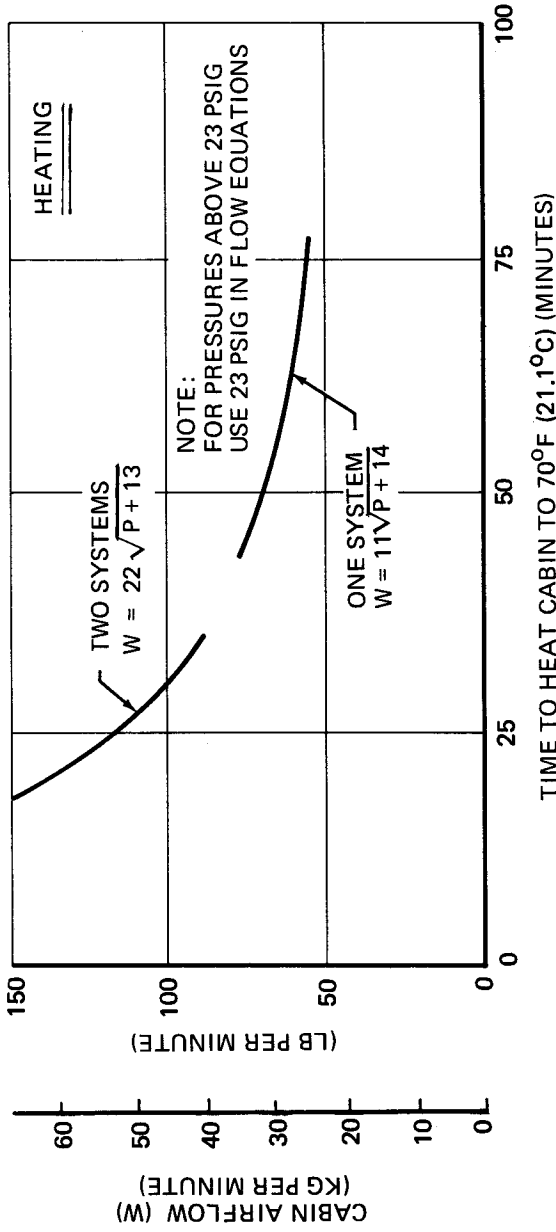

INITIAL CABIN TEMP AT 103°F (39.4°C). OUTSIDE AIR TEMP AT 103°F (39.4°C); SOLAR LOAD x 1200 BTU/HR. BRIGHT DAY; SOLAR IRRADIATION; NO GALLEY LOAD; DAY LIGHTING ON; NO PASSENGERS. P = 12 TO 70 PSIG AT THE GROUND CONNECTION. TEMP AT THE GROUND CONNECTION IS 410°F (210°C)

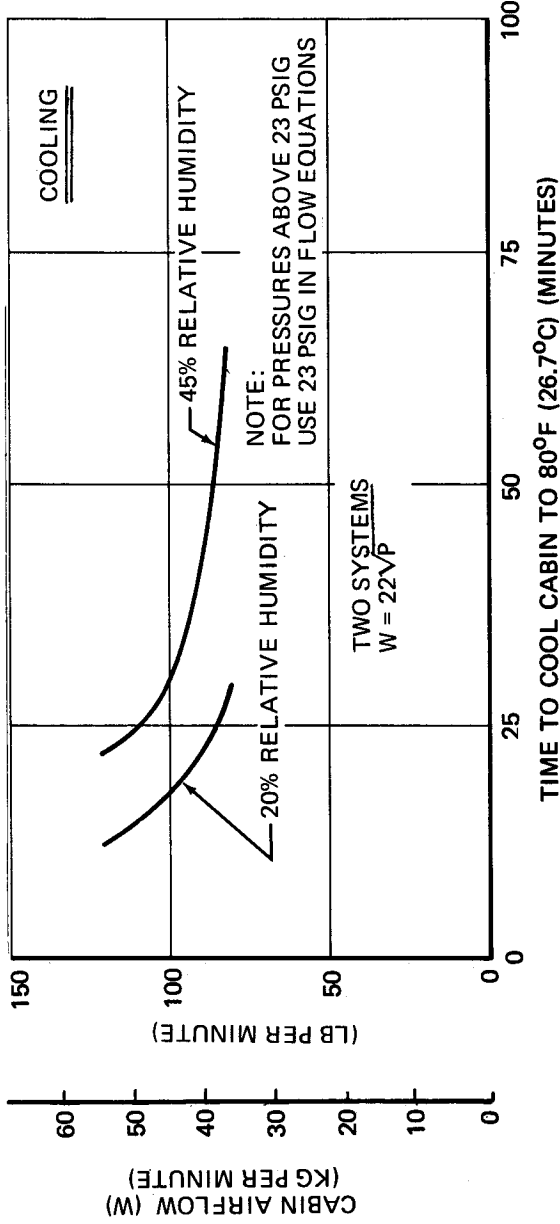

CAUTION: ELECTRICAL POWER IS REQUIRED WHENEVER THE AIR-CONDITIONING SYSTEM IS OPERATED

5.6 GROUND PNEUMATIC POWER REQUIREMENTS MODELS DC-9-15 AND -21

INITIAL CABIN TEMP AT 0°F (-17.8°C). OUTSIDE AIR TEMP AT 0°F (-17.8°C). NO GALLEY LOAD, NO GALLEY LOAD, DULL DAY, NO LIGHTS. P = 12 TO 70 PSIG AT THE GROUND CONNECTION. TEMP AT GROUND CONNECTION = 300°F (148.9°C)

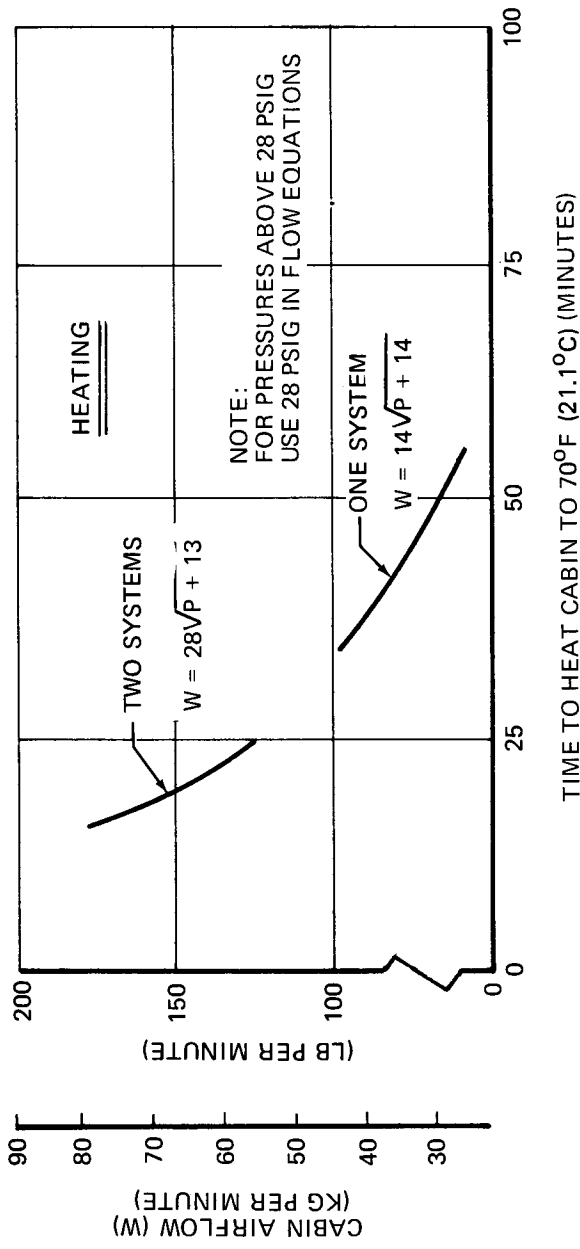

INITIAL CABIN TEMP AT 103°F (39.4°C). OUTSIDE AIR TEMP AT 103°F (39.4°C). SOLAR LOAD x 1600 BTU/HR. BRIGHT DAY; SOLAR IRRADIATION; NO GALLEY LOAD; NO GALLEY LOAD; DAY LIGHTING ON; NO PASSENGERS. P = 12 TO 70 PSIG AT THE GROUND CONNECTION. TEMP AT THE GROUND CONNECTOR IS 410°F (210°C)

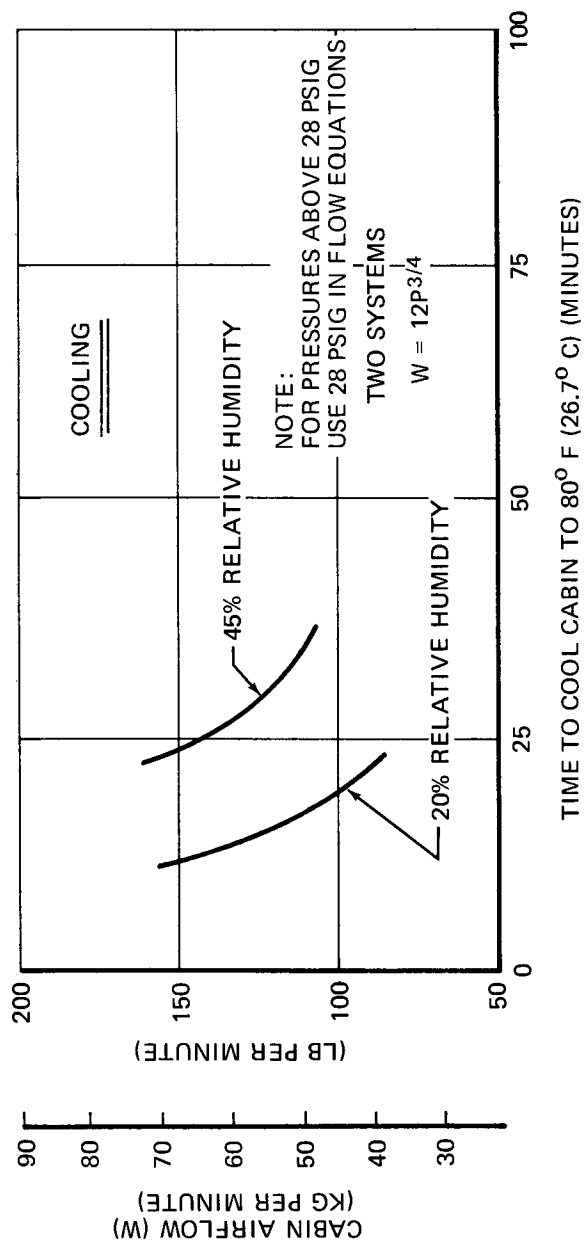

CAUTION: ELECTRICAL POWER IS REQUIRED WHENEVER THE AIR CONDITIONING SYSTEM IS OPERATED.

5.6 GROUND PNEUMATIC POWER REQUIREMENTS MODEL DC-9-32

INITIAL CABIN TEMP AT 0°F (-17.8°C). OUTSIDE AIR TEMP AT 0°F (-17.8°C). NO GALLEY LOAD, DULL DAY, NO LIGHTS. P = 12 TO 70 PSIG AT THE GROUND CONNECTION. TEMP AT GROUND CONNECTION = 300°F (148.9°C)

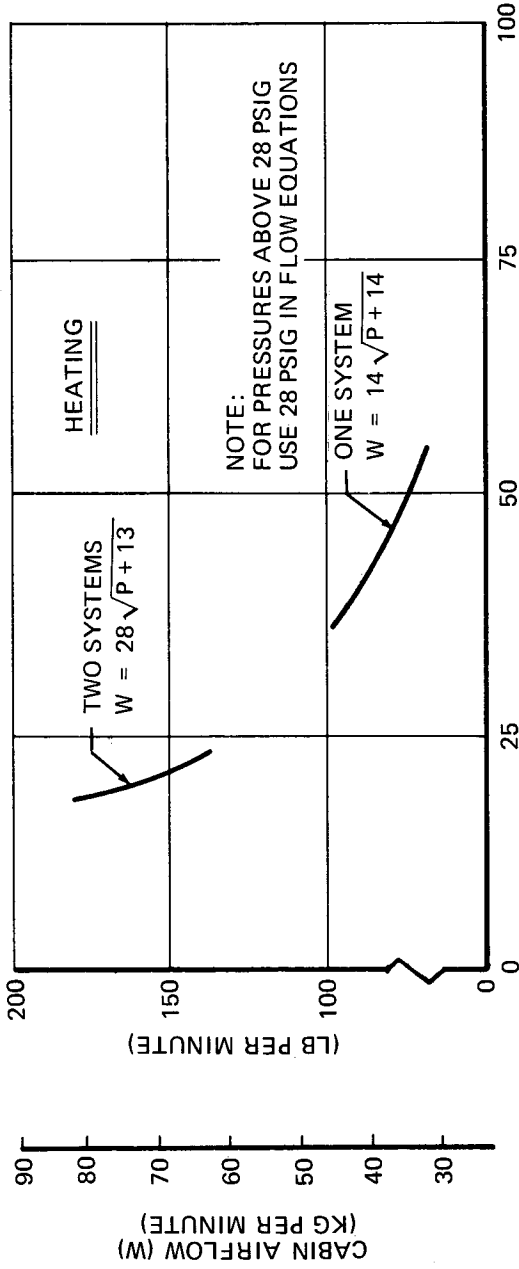

INITIAL CABIN TEMP AT 103°F (39.4°C). OUTSIDE AIR TEMP AT 103°F (39.4°C). SOLAR LOAD x 1655 BTU/HR. BRIGHT DAY; SOLAR IRRADIATION; NO GALLEY LOAD; DAY LIGHTING ON; NO PASSENGERS. P = 12 TO 70 PSIG AT THE GROUND CONNECTION. TEMP AT THE GROUND CONNECTION IS 410°F (210°C)

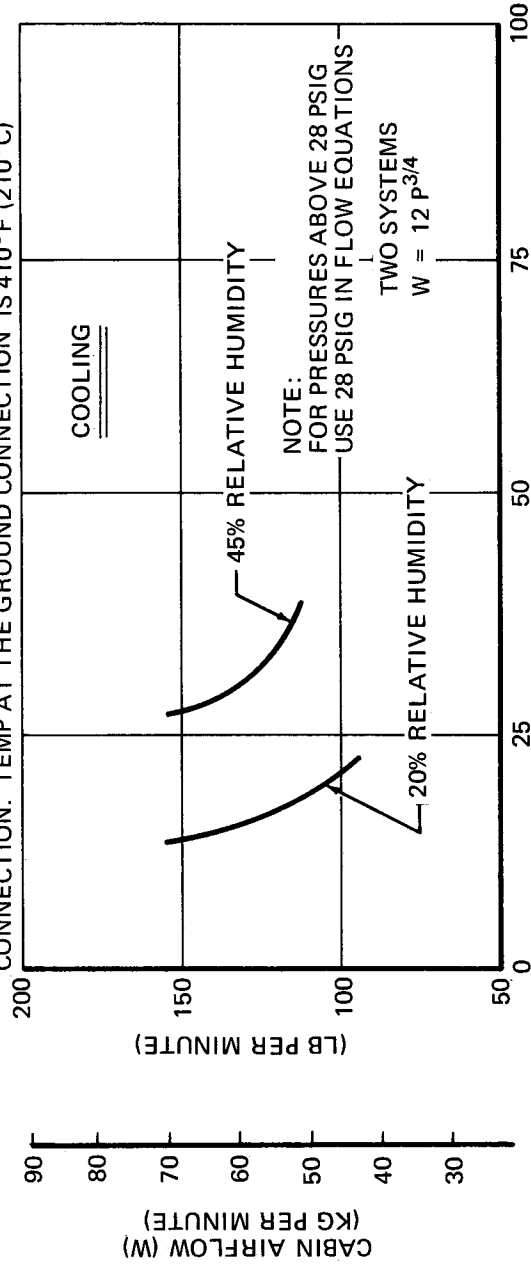

CAUTION: ELECTRICAL POWER IS REQUIRED WHENEVER THE AIR CONDITIONING SYSTEM IS OPERATED.

5.6 GROUND PNEUMATIC POWER REQUIREMENTS MODEL DC-9-41

INITIAL CABIN TEMP AT 0°F (-17.8°C). OUTSIDE AIR TEMP AT 0°F (-17.8°C). NO GALLEY LOAD, DULL DAY, NO LIGHTS. P = 12 TO 70 PSIG AT THE GROUND CONNECTION. TEMP AT GROUND CONNECTION = 300°F (148.9°C)

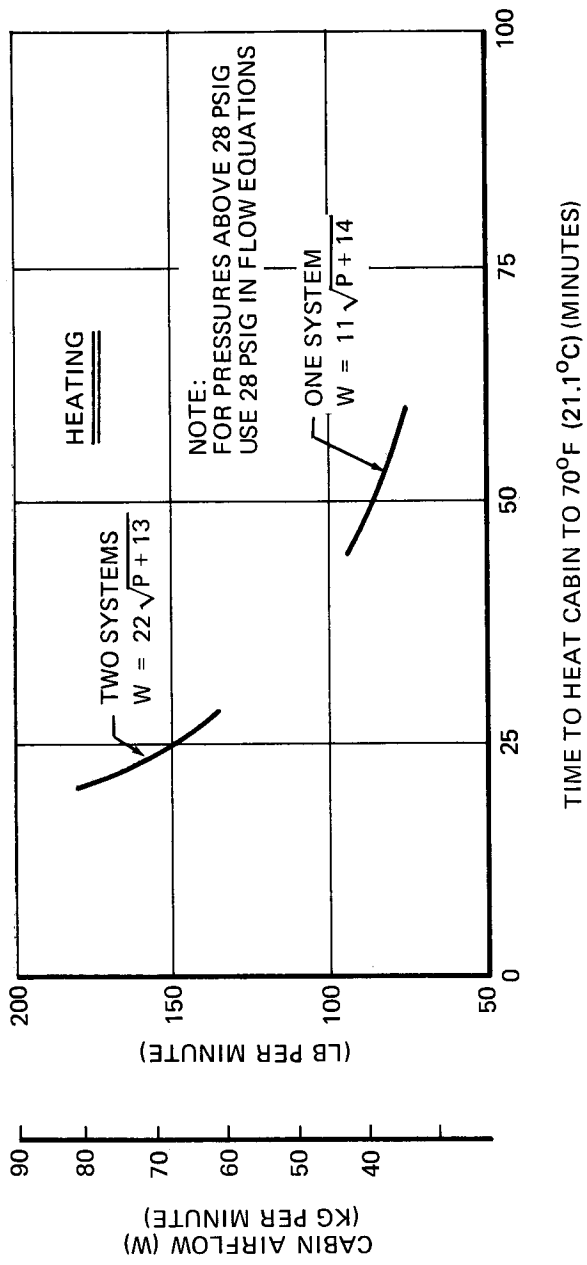

INITIAL CABIN TEMP AT 103°F (39.4°C). OUTSIDE AIR TEMP AT 103°F (39.4°C). SOLAR LOAD x 1900 BTU/HR. BRIGHT DAY; SOLAR IRRADIATION; NO GALLEY LOAD; DAY LIGHTING ON; NO PASSENGERS. P = 12-70 PSIG AT THE GROUND CONNECTION. TEMP AT THE GROUND CONNECTION IS 410°F (210°C)

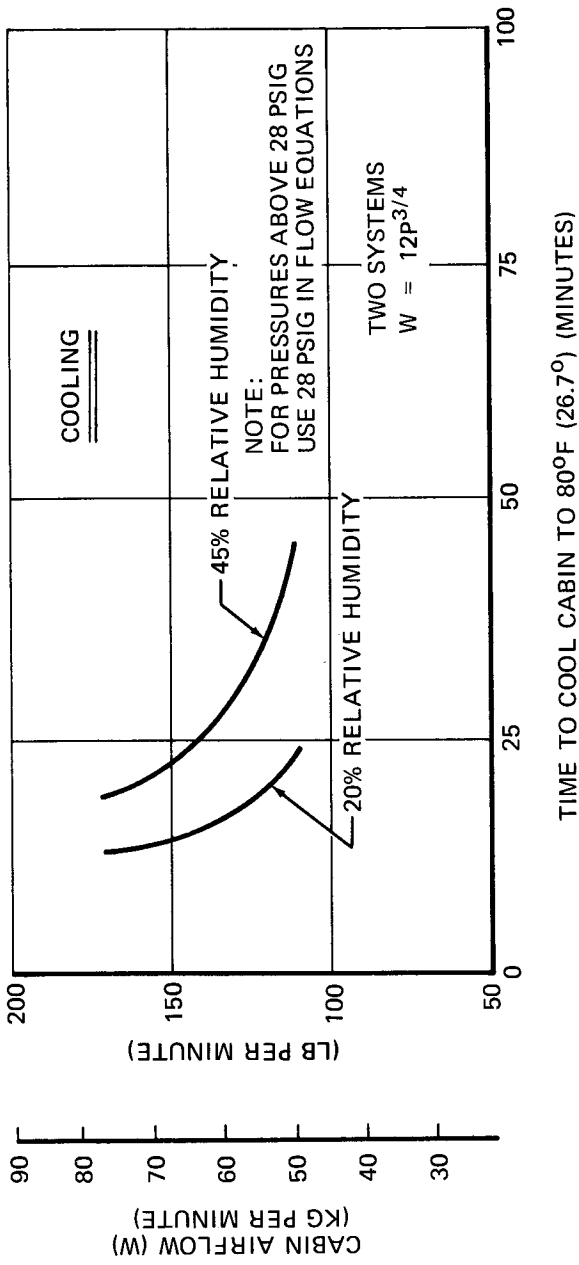

CAUTION: ELECTRICAL POWER IS REQUIRED WHENEVER THE AIR-CONDITIONING SYSTEM IS OPERATED.

5.6 GROUND PNEUMATIC POWER REQUIREMENTS MODEL DC-9-51

- ① CABIN TEMP AT 75°F (24°C). 5 CREW, 70 PASSENGERS, NO GALLEY LOAD. BRIGHT DAY; SOLAR IRRADIATION, SOLAR LOAD x 1200 BTU/HR. DAY ELECTRICAL LOAD x 2380 BTU/HR.
- ② CABIN TEMP AT 80°F (26.7°C). 5 CREW, 70 PASSENGERS, NO GALLEY LOAD. BRIGHT DAY; SOLAR IRRADIATION, SOLAR LOAD x 1200 BTU/HR. DAY ELECTRICAL LOAD x 2380 BTU/HR.
- ③ CABIN TEMP AT 75°F (24°C). 3 CREW MEMBERS ONLY. BRIGHT DAY; SOLAR IRRADIATION, SOLAR LOAD x 1200 BTU/HR. ELECTRICAL LOAD x 2380 BTU/HR. GALLEY LOAD x 3000 BTU/HR.
- ④ ⑤ AND ⑥ CABIN TEMP AT 70°F (21.1°C). NO CREW, NO PASSENGERS. DULL DAY OR NIGHT; NO SOLAR IRRADIATION, NO ELECTRICAL LOAD, NO GALLEY LOAD

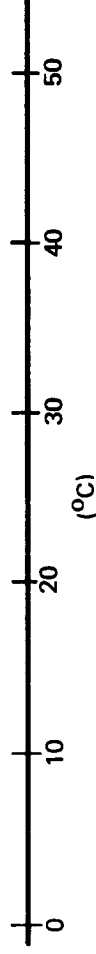
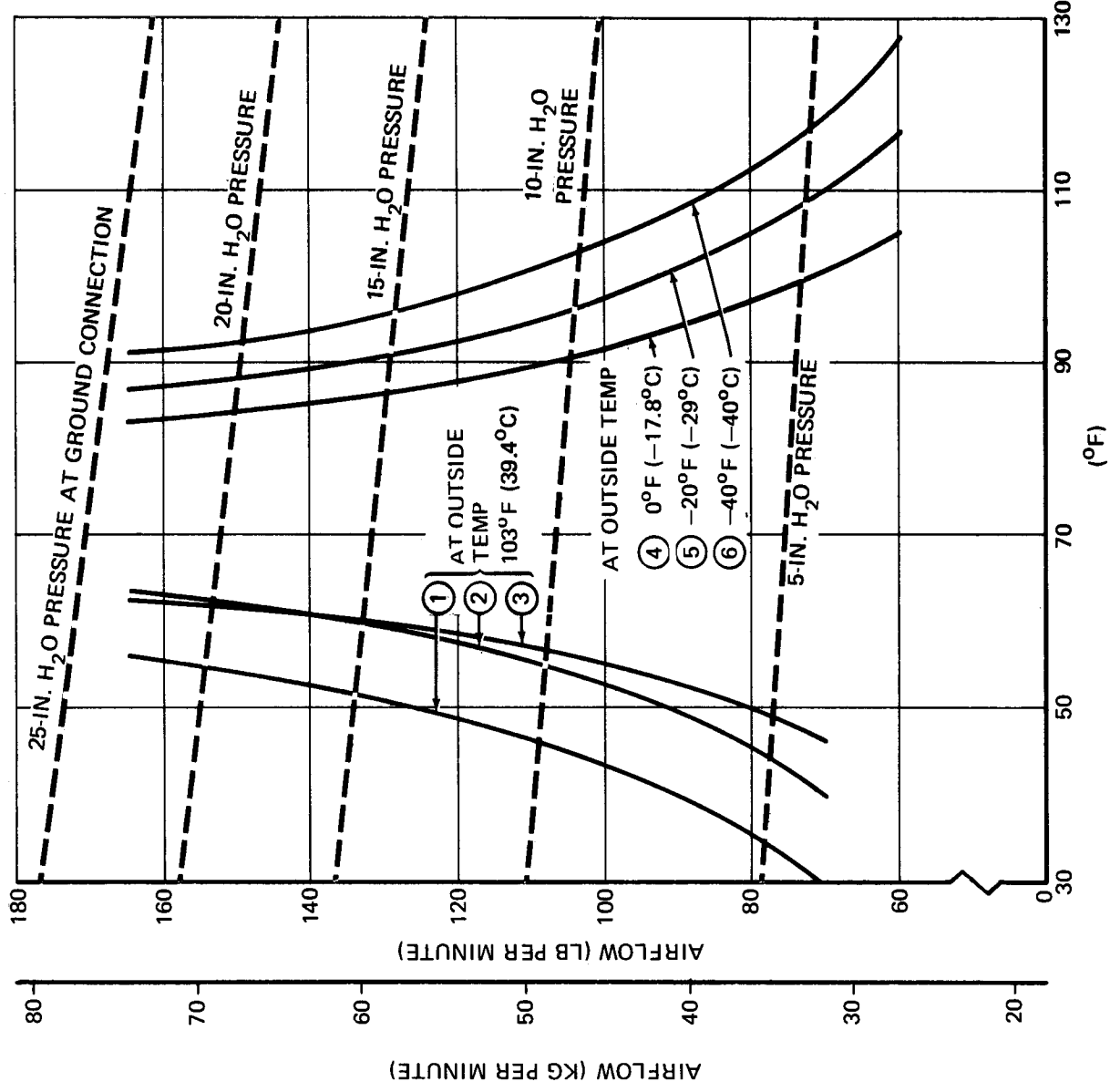

5.7 PRECONDITIONED AIRFLOW REQUIREMENTS MODELS DC-9-15 AND -21

- ① CABIN TEMP AT 75°F (24°C). 5 CREW, 105 PASSENGERS, NO GALLEY LOAD. BRIGHT DAY; SOLAR IRRADIATION, SOLAR LOAD x 1600 BTU/HR. DAY ELECTRICAL LOAD x 2380 BTU/HR.
- ② CABIN TEMP AT 80°F (26.7°C). 5 CREW, 105 PASSENGERS, NO GALLEY LOAD. BRIGHT DAY; SOLAR IRRADIATION, SOLAR LOAD x 1600 BTU/HR. DAY ELECTRICAL LOAD x 2380 BTU/HR.
- ③ CABIN TEMP AT 75°F (24°C). 3 CREW MEMBERS ONLY. BRIGHT DAY. SOLAR IRRADIATION, SOLAR LOAD x 1600 BTU/HR. ELECTRICAL LOAD x 2380 BTU/HR. GALLEY LOAD x 3000 BTU/HR.
- ④ ⑤ AND ⑥ CABIN TEMP AT 70°F (21.1°C). NO CREW, NO PASSENGERS. DULL DAY OR NIGHT, NO SOLAR IRRADIATION, NO ELECTRICAL LOAD, NO GALLEY LOAD

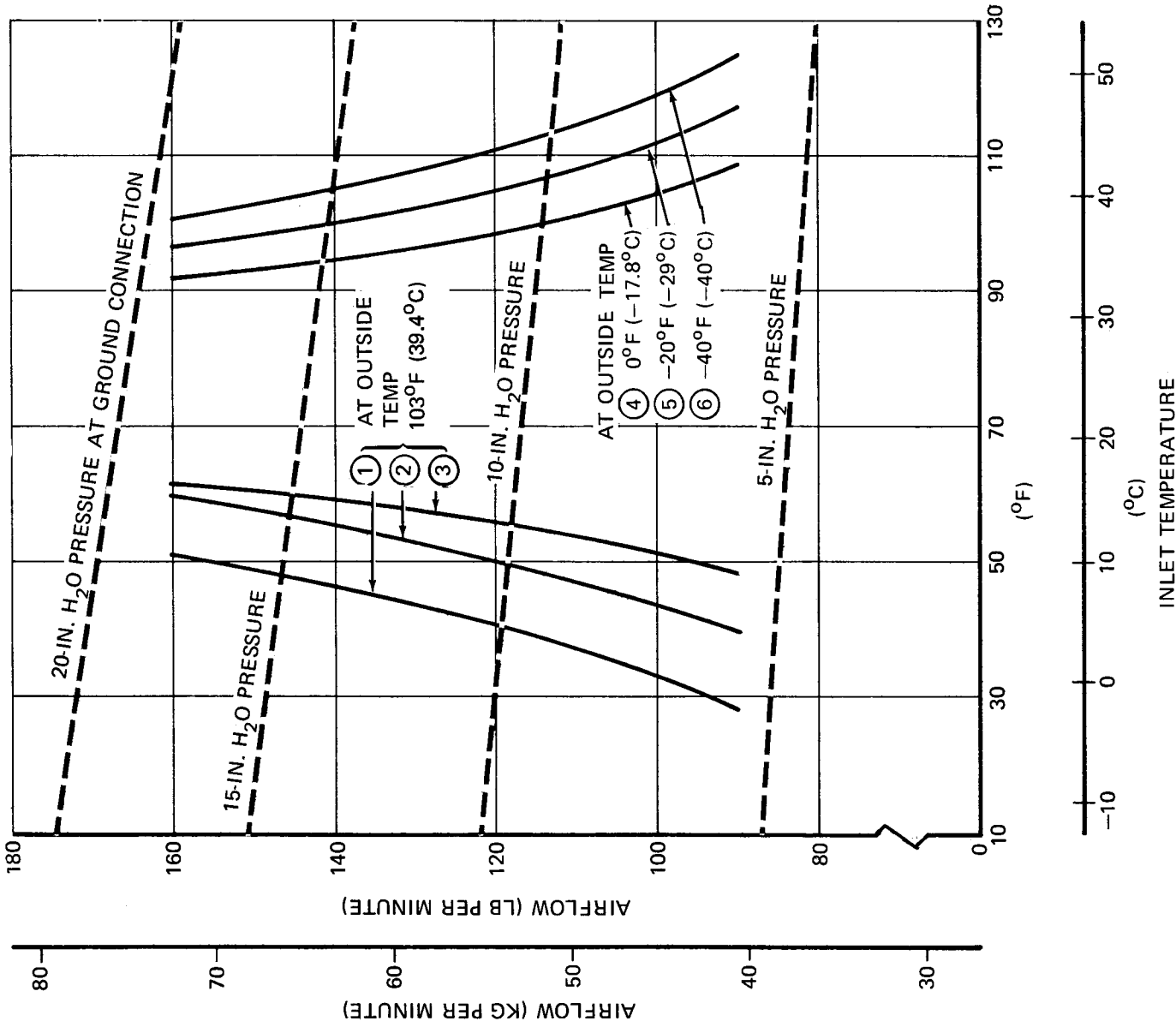

5.7 PRECONDITIONED AIRFLOW REQUIREMENTS MODEL DC-9-32

- ① CABIN TEMP AT 75°F (24°C). 5 CREW, 117 PASSENGERS. NO GALLEY LOAD. BRIGHT DAY; SOLAR IRRADIATION, SOLAR LOAD x 1655 BTU/HR. DAY ELECTRICAL LOAD x 2380 BTU/HR.
- ② CABIN TEMP AT 80°F (26.7°C). 5 CREW, 117 PASSENGERS. NO GALLEY LOAD. BRIGHT DAY; SOLAR IRRADIATION, SOLAR LOAD x 1655 BTU/HR. DAY ELECTRICAL LOAD x 2380 BTU/HR.
- ③ CABIN TEMP AT 75°F (24°C). 3 CREW MEMBERS ONLY. BRIGHT DAY; SOLAR IRRADIATION, SOLAR LOAD x 1655 BTU/HR. ELECTRICAL LOAD x 2380 BTU/HR. GALLEY LOAD x 3000 BTU/HR.
- ④ ⑤ AND ⑥ CABIN TEMP AT 70°F (21.1°C). NO CREW, NO PASSENGERS. DULL DAY OR NIGHT; NO SOLAR IRRADIATION. NO ELECTRICAL LOAD, NO GALLEY LOAD

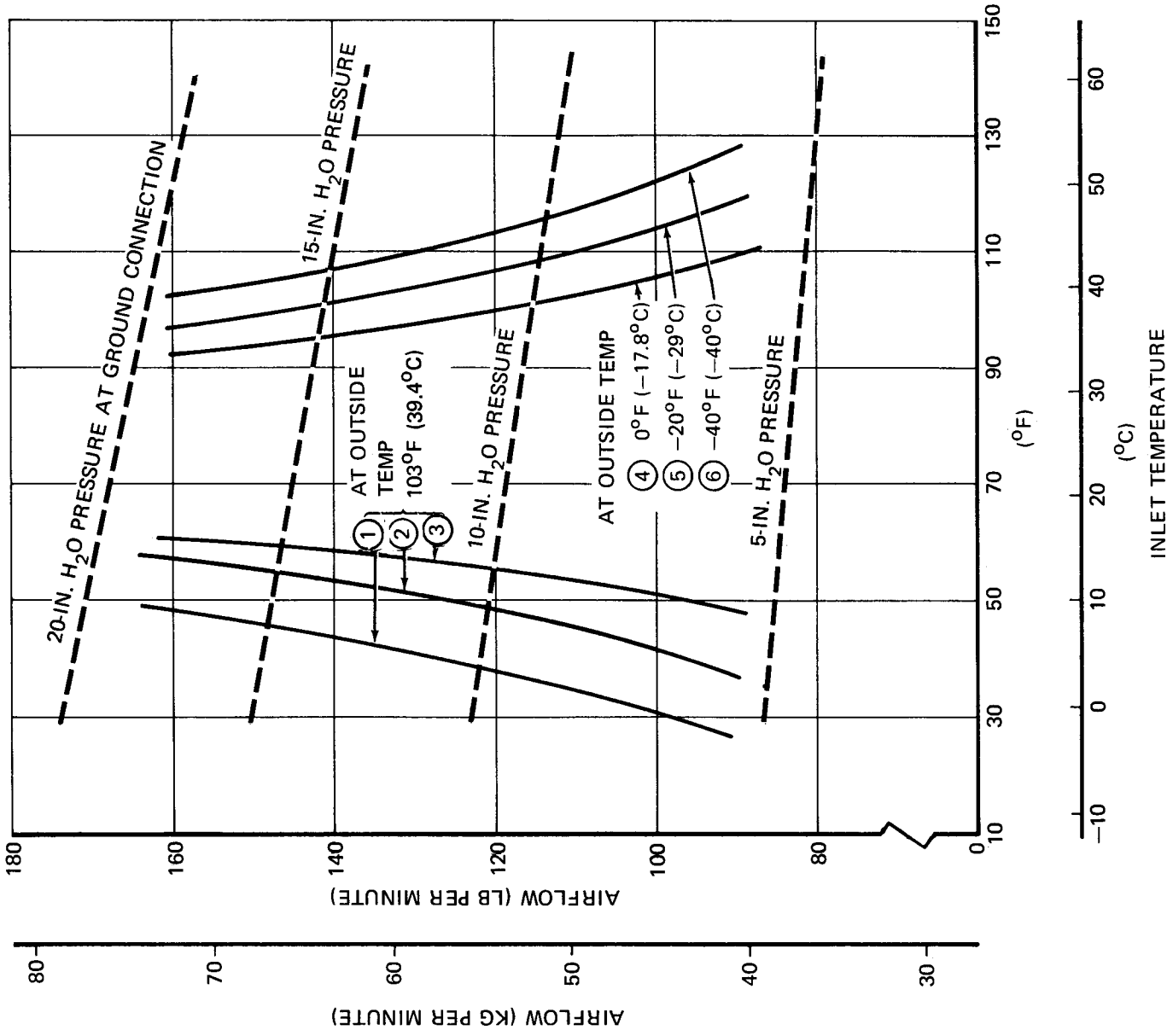

5.7 PRECONDITIONED AIRFLOW REQUIREMENTS MODEL DC-9-41

- ① CABIN TEMP AT 75°F (24°C). 5 CREW, 143 PASSENGERS. NO GALLEY LOAD. BRIGHT DAY; SOLAR IRRADIATION, SOLAR LOAD x 2060 BTU/HR. DAY ELECTRICAL LOAD x 4080 BTU/HR.
- ② CABIN TEMP AT 80°F (26.7°C). 5 CREW, 143 PASSENGERS. NO GALLEY LOAD. BRIGHT DAY; SOLAR IRRADIATION, SOLAR LOAD x 2060 BTU/HR. DAY ELECTRICAL LOAD x 4080 BTU/HR.
- ③ CABIN TEMP AT 75°F (24°C). 3 CREW MEMBERS ONLY. BRIGHT DAY; SOLAR IRRADIATION, SOLAR LOAD x 2060 BTU/HR. ELECTRICAL LOAD x 4080 BTU/HR. GALLEY LOAD x 3000 BTU/HR.
- ④ ⑤ AND ⑥ CABIN TEMP AT 70°F (21.1°C). NO CREW, NO PASSENGERS. DULL DAY OR NIGHT; NO SOLAR IRRADIATION, NO ELECTRICAL LOAD, NO GALLEY LOAD

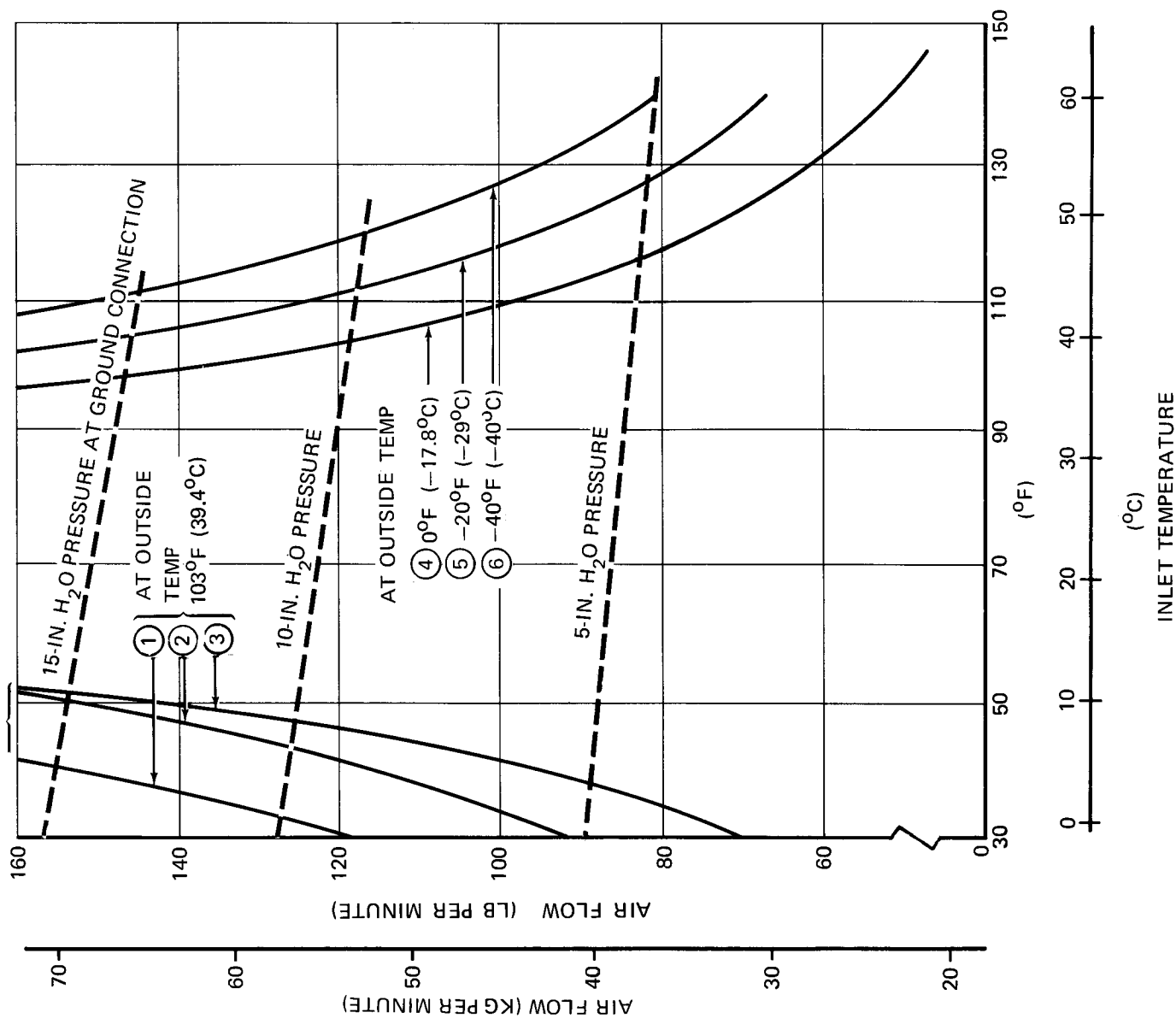

5.7 PRECONDITIONED AIRFLOW REQUIREMENTS MODEL DC-9-51

5.8 Ground Towing Requirements

In order to determine the drawbar pull and total traction wheel load experienced by a tow vehicle, the airplane weight, pavement slope, coefficient of friction, and engine thrust must be known.

In the example for the Model DC-9, Page 158, the airplane gross weight is 82,000 pounds, the pavement slope is 2 percent, the coefficient of friction is 0.57, and there is no engine thrust. From these conditions, the drawbar pull is 4300 pounds and the total traction wheel load is 7800 pounds.

- UNUSUAL BREAKAWAY CONDITIONS NOT REFLECTED
- ESTIMATED FOR RUBBER TIRED TOW VEHICLES
- COEFFICIENTS OF FRICTION (μ) APPROXIMATE

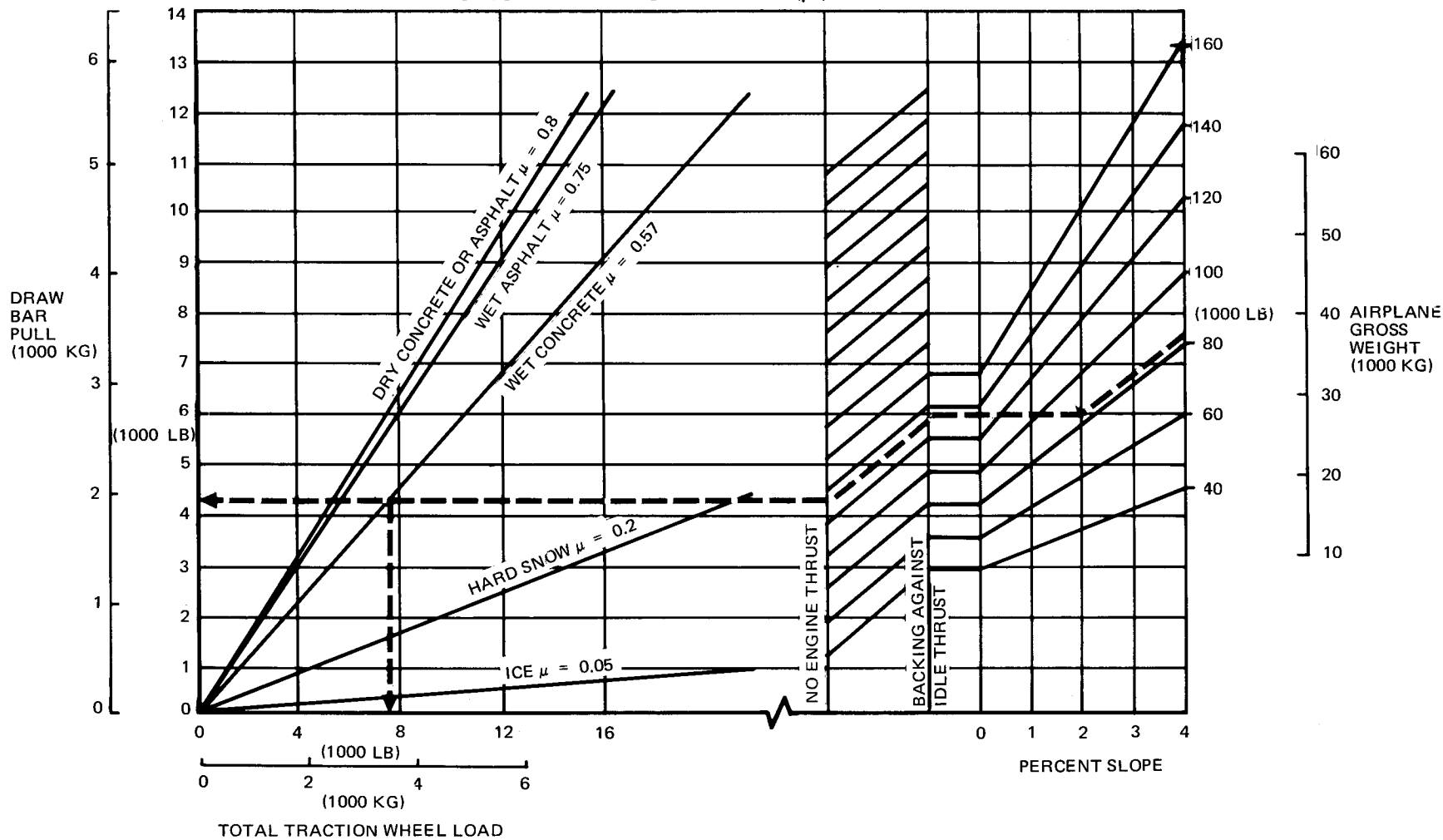

5.8 GROUND TOWING REQUIREMENTS

MODEL DC-9

6.0 OPERATING CONDITIONS

- 6.1 Jet Engine Exhaust Velocities and Temperatures**
- 6.2 Airport and Community Noise**

- NOTES: 1. THESE CONTOURS ARE TO BE USED AS GUIDELINES ONLY SINCE OPERATIONAL ENVIRONMENT VARIES GREATLY – OPERATIONAL SAFETY ASPECTS ARE THE RESPONSIBILITY OF THE USER/PLANNER
2. ALL VELOCITY VALUES ARE STATUTE MILES PER HOUR
3. CROSSWINDS WILL HAVE CONSIDERABLE EFFECT ON CONTOURS
4. SEA LEVEL STATIC – STANDARD DAY – ZERO RAMP GRADIENT
5. ALL ENGINES AT SAME THRUST

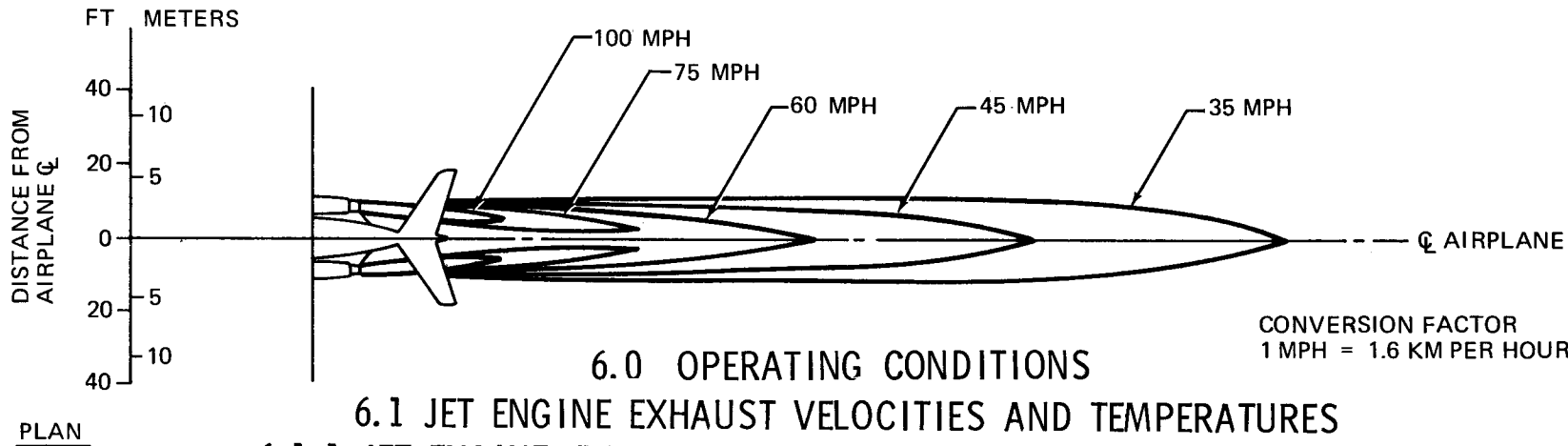
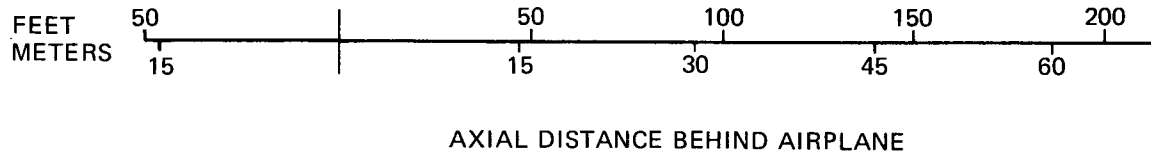
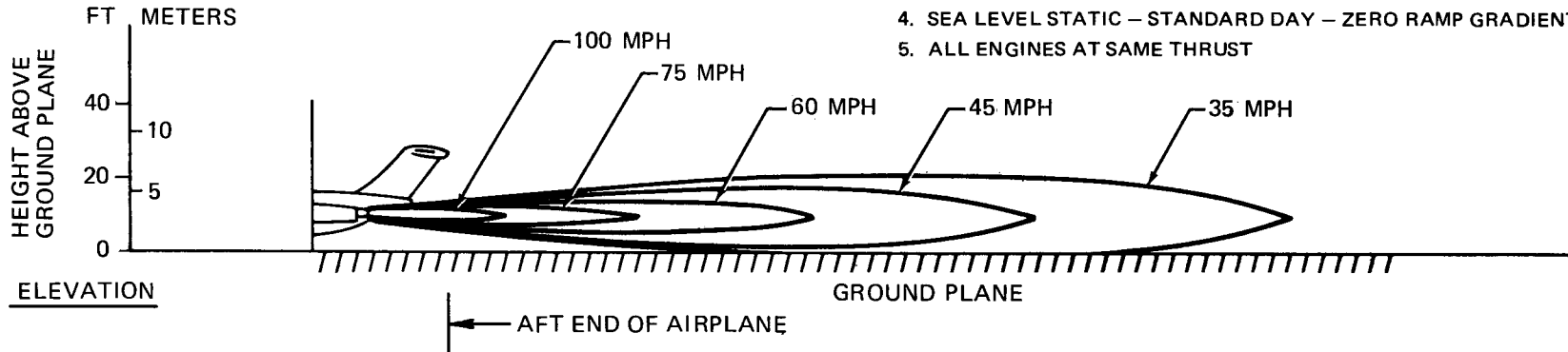

CONVERSION FACTOR
1 MPH = 1.6 KM PER HOUR

6.0 OPERATING CONDITIONS

6.1 JET ENGINE EXHAUST VELOCITIES AND TEMPERATURES

6.1.1 JET ENGINE EXHAUST VELOCITY CONTOURS, BREAKAWAY POWER

DC-9 MODELS

(SERIES 10 THROUGH 50)

- NOTES: 1. ALL TEMPERATURES ARE DEGREES FAHRENHEIT
 2. THESE CONTOURS ARE TO BE USED AS GUIDELINES ONLY SINCE OPERATIONAL ENVIRONMENT VARIES GREATLY – OPERATIONAL SAFETY ASPECTS ARE THE RESPONSIBILITY OF THE USER/PLANNER
 3. CROSSWINDS WILL HAVE CONSIDERABLE EFFECT ON CONTOURS
 4. SEA LEVEL STATIC–STANDARD DAY–ZERO RAMP GRADIENT
 5. ALL ENGINES AT SAME THRUST

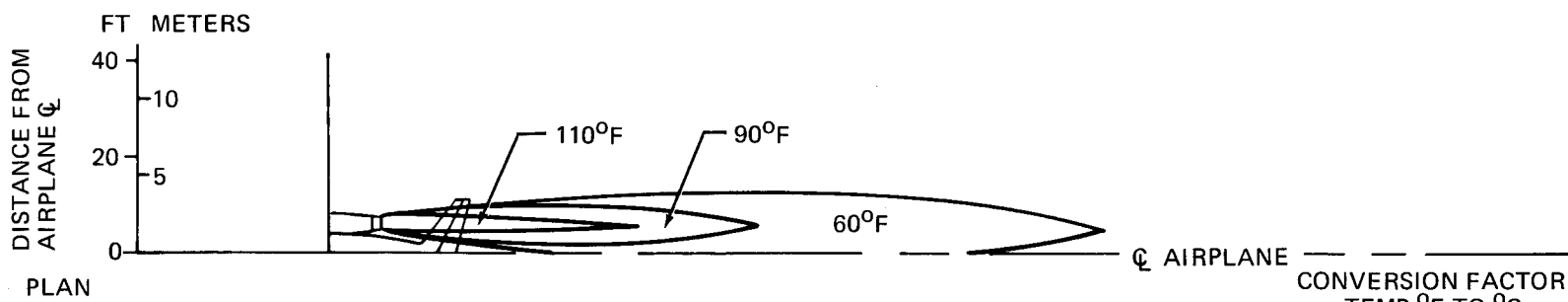
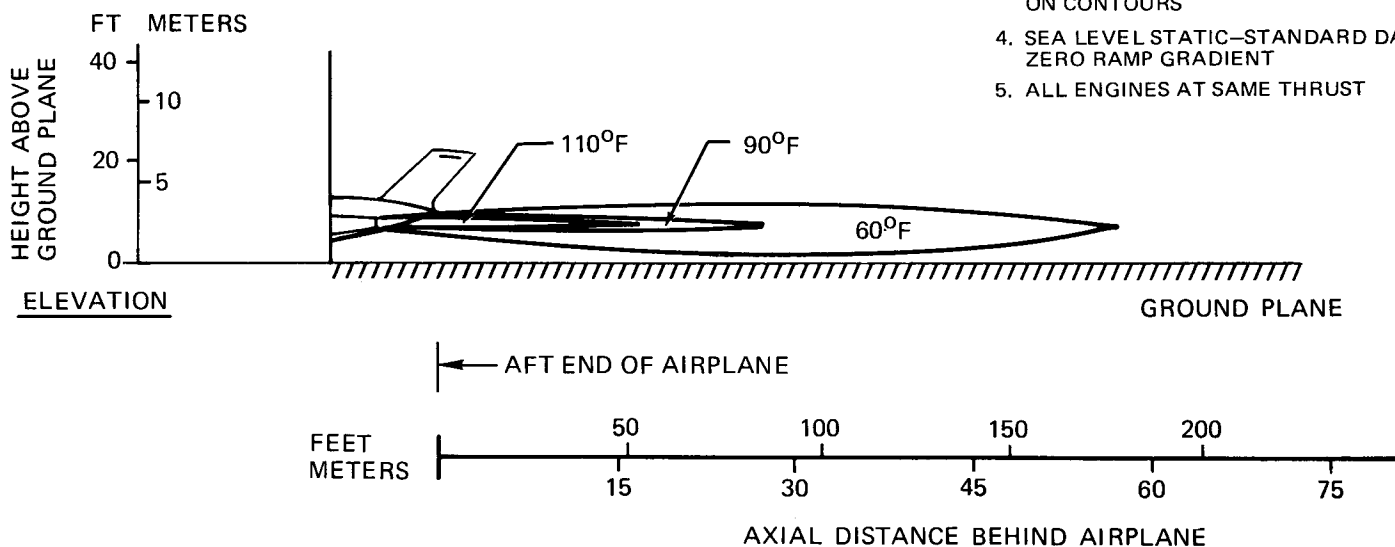

CONVERSION FACTOR
 TEMP °F TO °C
 $^{\circ}\text{C} = \frac{(^{\circ}\text{F} - 32)}{1.8}$

6.1 JET EXHAUST VELOCITIES AND TEMPERATURES
 6.1.2 JET ENGINE EXHAUST TEMPERATURE CONTOURS, BREAKAWAY POWER
 DC-9 MODELS
 (SERIES 10 THROUGH 50)

- NOTES: 1. THESE CONTOURS ARE TO BE USED AS GUIDELINES ONLY SINCE OPERATIONAL ENVIRONMENT VARIES GREATLY – OPERATIONAL SAFETY ASPECTS ARE THE RESPONSIBILITY OF THE USER/PLANNER
2. ALL VELOCITY VALUES ARE STATUTE MILES/HOUR
3. CROSSWINDS WILL HAVE CONSIDERABLE EFFECT ON CONTOURS
4. SEA LEVEL STATIC – STANDARD DAY – ZERO RAMP GRADIENT
5. ALL ENGINES AT SAME THRUST

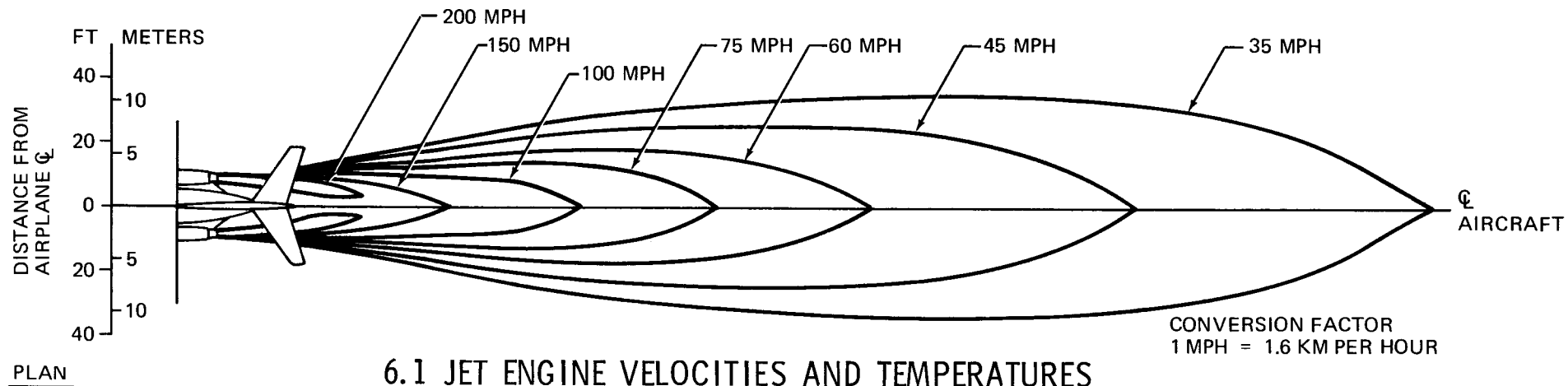
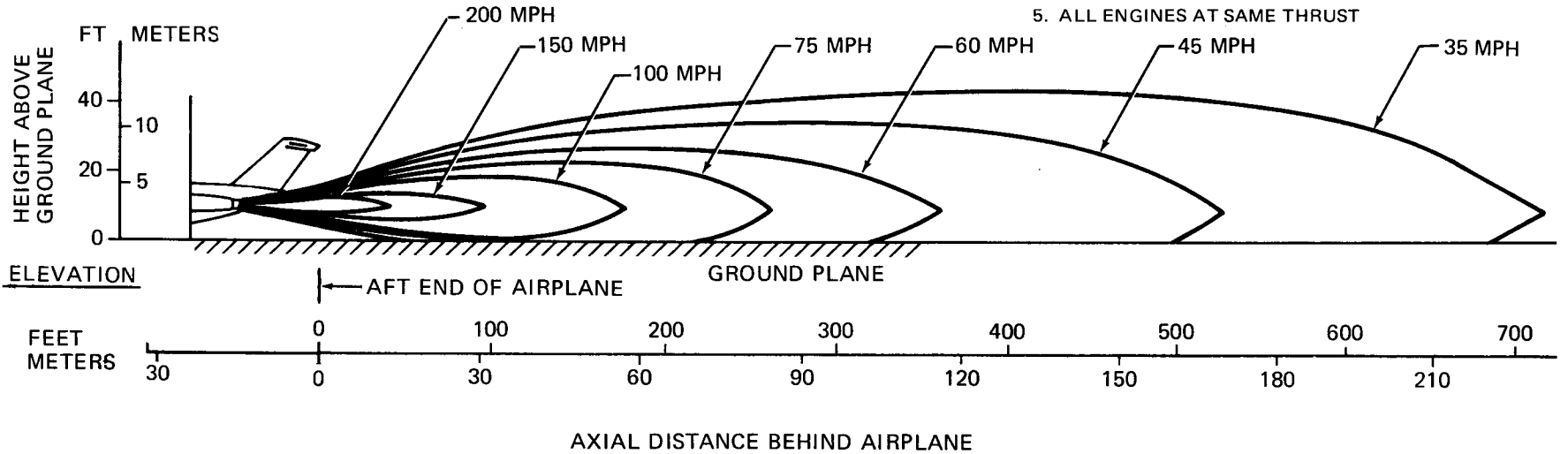

6.1 JET ENGINE VELOCITIES AND TEMPERATURES
 6.1.3 JET ENGINE EXHAUST VELOCITY CONTOURS, TAKEOFF POWER
 DC-9 MODELS
 (SERIES 10 THROUGH 50)

- NOTES: 1. ALL TEMPERATURES ARE DEGREES FAHRENHEIT
 2. THESE CONTOURS ARE TO BE USED AS GUIDELINES ONLY SINCE OPERATIONAL ENVIRONMENT VARIES GREATLY — OPERATIONAL SAFETY ASPECTS ARE THE RESPONSIBILITY OF THE USER/PLANNER
 3. CROSSWINDS WILL HAVE CONSIDERABLE EFFECT ON CONTOURS
 4. SEA LEVEL STATIC—STANDARD DAY—ZERO RAMP GRADIENT
 5. ALL ENGINES AT SAME THRUST

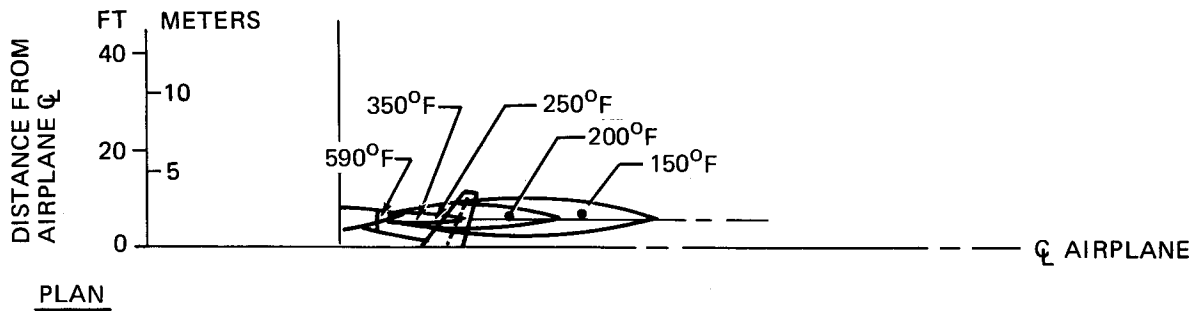
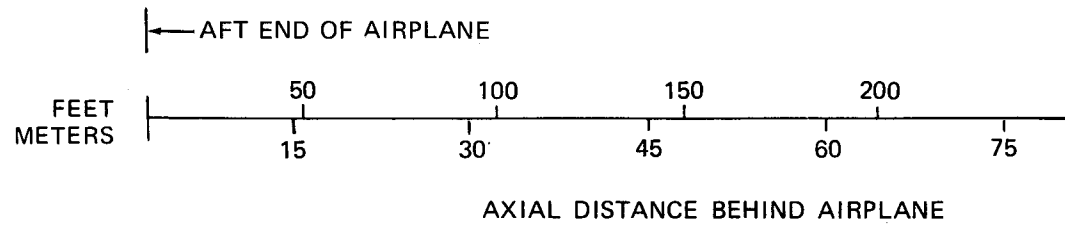
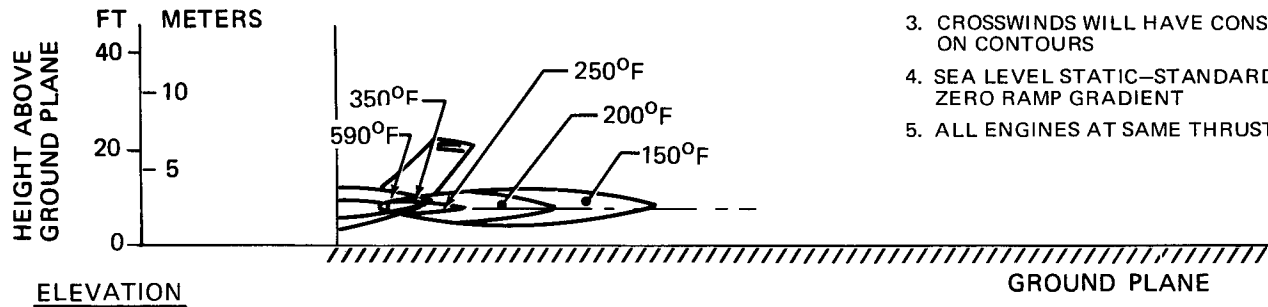

CONVERSION FACTOR
 TEMP °F TO °C

$$^{\circ}\text{C} = \frac{(^{\circ}\text{F} - 32)}{1.8}$$

6.1 JET ENGINE VELOCITIES AND TEMPERATURES
 6.1.4 JET ENGINE EXHAUST TEMPERATURE CONTOURS, TAKEOFF POWER
 DC-9 MODELS
 (SERIES 10 THROUGH 50)

- NOTES: 1. THESE CONTOURS ARE TO BE USED AS GUIDELINES ONLY SINCE OPERATIONAL ENVIRONMENT VARIES GREATLY – OPERATIONAL SAFETY ASPECTS ARE THE RESPONSIBILITY OF THE USER/PLANNER
- 2. ALL VELOCITY VALUES ARE STATUTE MILES PER HOUR
- 3. CROSSWINDS WILL HAVE CONSIDERABLE EFFECT ON CONTOURS
- 4. SEA LEVEL STATIC – STANDARD DAY – ZERO RAMP GRADIENT
- 5. ALL ENGINES AT SAME THRUST

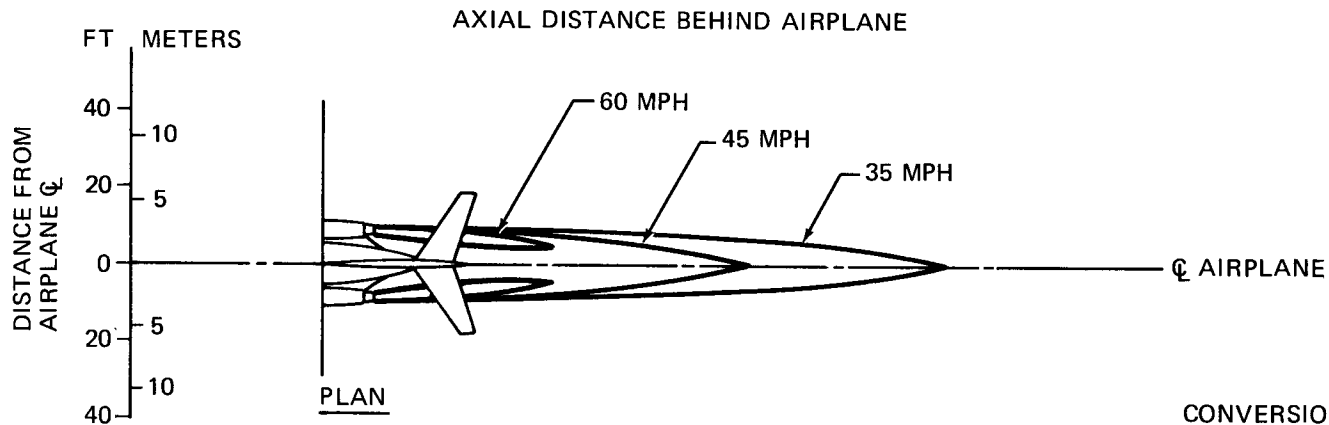
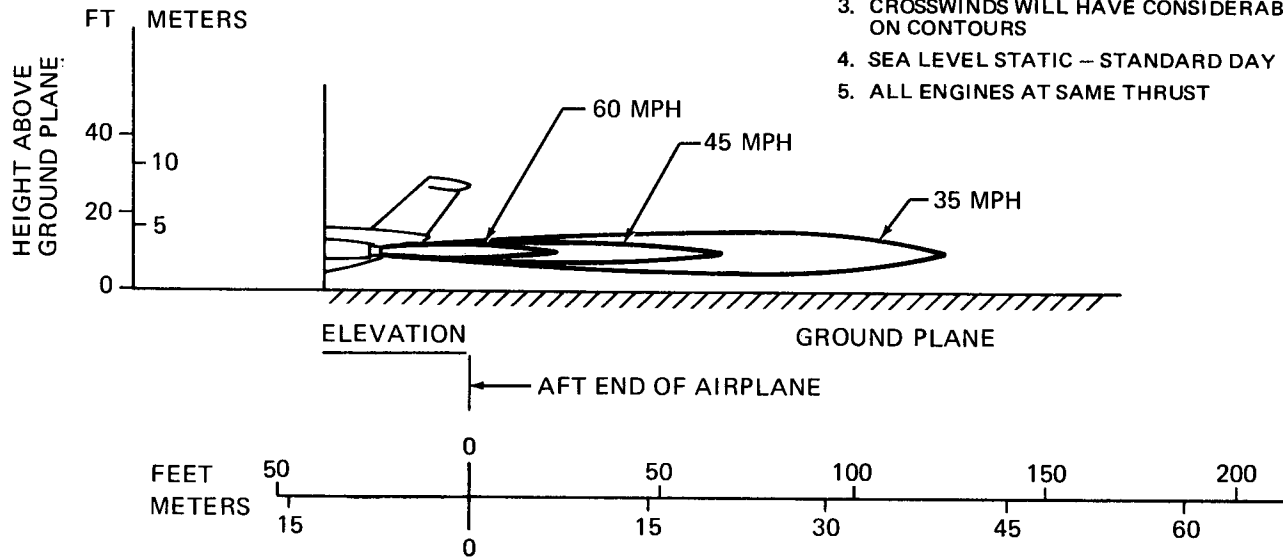

CONVERSION FACTOR
1 MPH = 1.6 KM PER HOUR

6.1 JET ENGINE VELOCITIES AND TEMPERATURES
6.1.5 JET ENGINE EXHAUST VELOCITY CONTOURS, IDLE POWER
DC-9 MODELS
(SERIES 10 THROUGH 50)

- NOTES: 1. ALL TEMPERATURES ARE DEGREES FAHRENHEIT
 2. THESE CONTOURS ARE TO BE USED AS GUIDE-LINES ONLY SINCE OPERATIONAL ENVIRONMENT VARIES GREATLY – OPERATIONAL SAFETY ASPECTS ARE THE RESPONSIBILITY OF THE USER/PLANNER
 3. CROSSWINDS WILL HAVE CONSIDERABLE EFFECT ON CONTOURS
 4. SEA LEVEL STATIC-STANDARD DAY – ZERO RAMP GRADIENT
 5. ALL ENGINES AT SAME THRUST

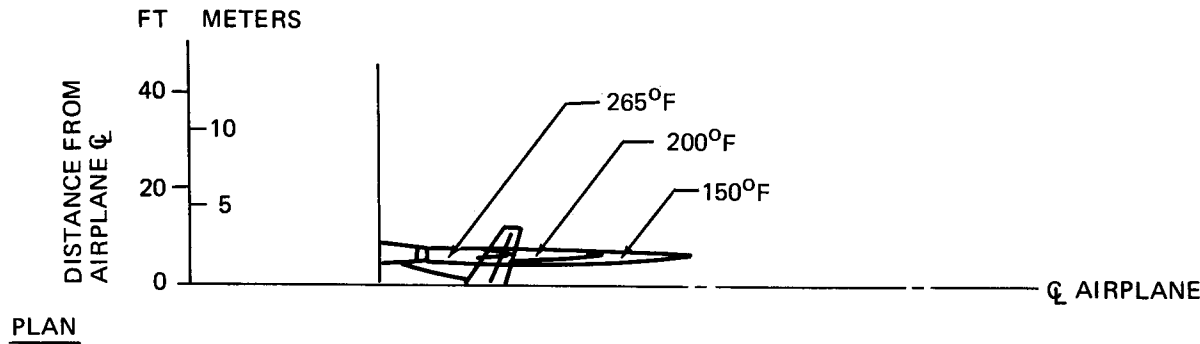
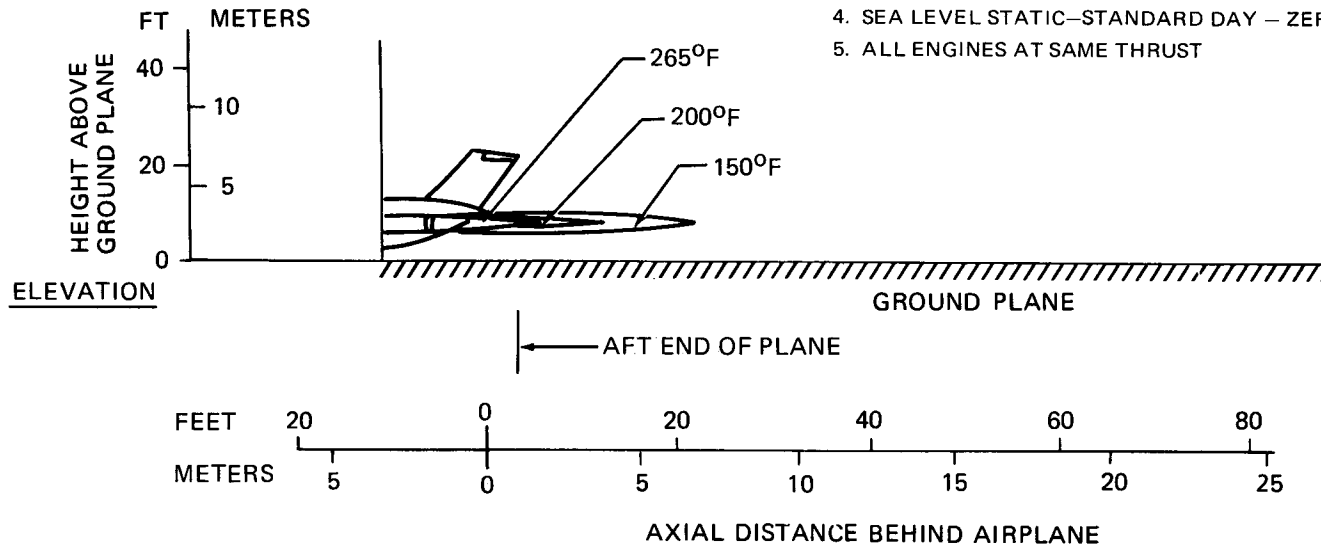

CONVERSION FACTOR
 TEMP °F TO °C
 $^{\circ}\text{C} = \frac{(^{\circ}\text{F} - 32)}{1.8}$

6.1. JET ENGINE VELOCITIES AND TEMPERATURES
 6.1.6 JET ENGINE EXHAUST TEMPERATURE CONTOURS, IDLE POWER
 DC-9 MODELS
 (SERIES 10 THROUGH 50)

6.2 Airport and Community Noise

Aircraft noise is of major concern to the airport and community planner. The airport is a major element in the community's transportation system and, as such, is vital to its growth. However, the airport must also be a good neighbor, and this can be accomplished only with proper planning. Since aircraft noise extends beyond the boundaries of the airport, it is vital to consider the impact on surrounding communities. Many means have been devised to provide the planner with a tool to estimate the impact of airport operations. Too often they oversimplify noise to the point where the results become erroneous. Noise is not a simple subject; therefore, there are no simple answers.

The cumulative noise contour is an effective tool. However, care must be exercised to ensure that the contours, used correctly, estimate the noise resulting from aircraft operations conducted at an airport.

The size and shape of the single-event contours, which are inputs into the cumulative noise contours, are dependent upon numerous factors. They include:

1. Operational Factors

- (a) Aircraft Weight – Aircraft weight is dependent on distance to be traveled, en route winds, payload, and anticipated aircraft delay upon reaching the destination.
- (b) Engine Power Settings – The rates of ascent and descent and the noise levels emitted at the source are influenced by the power setting used.
- (c) Airport Altitude – Higher airport altitude will affect engine performance and thus can influence noise.

Condition 2

Landing:	Takeoff:
85 Percent of Maximum Structural Landing Weight	80 Percent of Maximum Gross Takeoff Weight
10-Knot Headwind	10-Knot Headwind
3-Deg Approach	59°F
59°F	Humidity 70 Percent
Humidity 70 Percent	

As indicated from these data, the contour size varies substantially with operating and atmospheric conditions. Most aircraft operations are, of course, conducted at less than maximum gross weights because average flight distances are much shorter than maximum aircraft range capability and average load factors are less than 100 percent. Therefore, in developing cumulative contours for planning purposes, it is recommended that the airlines serving a particular city be contacted to provide operational information.

In addition, there are no universally accepted methods for developing aircraft noise contours or for relating the acceptability of specific noise zones to specific land uses. It is therefore expected that noise contour data for particular aircraft and the impact assessment methodology will be changing. To ensure that currently available information of this type is used in any planning study, it is recommended that it be obtained directly from the Office of Environmental Quality in the Federal Aviation Administration in Washington, D.C.

It should be noted that the contours shown herein are only for illustrating the impact of operating and atmospheric conditions and do not represent the single-event contour of the family of aircraft described in this document. It is expected that the cumulative contours will be developed as required by planners using the data and methodology applicable to their specific study.

2. Atmospheric Conditions – Sound Propagation

- (a) Wind – With stronger headwinds, the aircraft can take off and climb more rapidly relative to the ground. Also, winds can influence the distribution of noise in surrounding communities.
 - (b) Temperature and Relative Humidity – The absorption of noise in the atmosphere along the transmission path between the aircraft and the ground observer varies with both temperature and relative humidity.
3. Surface Condition Shielding, Extra Ground Attenuation (EGA)
- (a) Terrain – If the ground slopes down after takeoff or up before landing, noise will be reduced since the aircraft will be at a higher altitude above ground. Additionally, hills, shrubs, trees, and large buildings can act as sound buffers.

All of these factors can alter the shape and size of the contours appreciably. To demonstrate the effect of some of these factors, estimated noise level contours for two different operating conditions are shown below. These contours reflect a given noise level upon a ground level plane at runway elevation.

Condition 1

Landing:
Maximum Structural Landing Weight
10-knot Headwind
3-Deg Approach
84°F
Humidity 15 Percent

Takeoff:
Maximum Gross Takeoff Weight
Zero Wind
84°F
Humidity 15 Percent

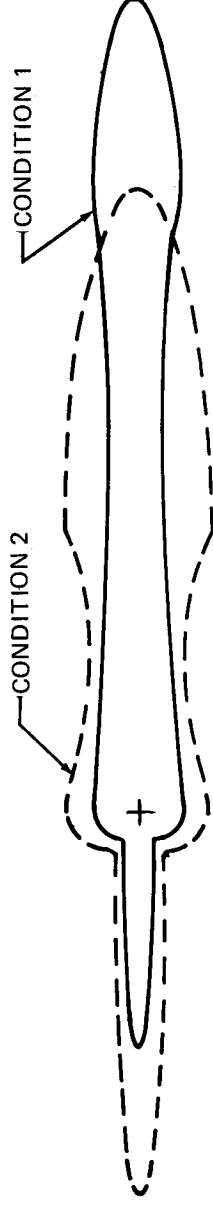

7.0 PAVEMENT DATA

- 7.1 General Information**
- 7.2 Footprint**
- 7.3 Maximum Pavement Loads**
- 7.4 Landing Gear Loading on Pavement**
- 7.5 Flexible Pavement Requirements, U.S. Corps of Engineers Design Method**
- 7.6 Flexible Pavement Requirements, LCN Conversion**
- 7.7 Rigid Pavement Requirements, Portland Cement Association Design Method**
- 7.8 Rigid Pavement Requirements, LCN Conversion**

7.0 PAVEMENT DATA

7.1 General Information

A brief description of the pavement charts which follow will be helpful in their use for airport planning. Each airplane configuration is depicted with a range of four loads imposed on the main landing gear to aid in interpolation between the discrete values shown. All pavement requirement charts present data at a constant main gear tire pressure. The tire pressure used will produce a tire deflection of 32 percent with the airplane loaded to its maximum ramp weight, and with the C.G. at its maximum permissible aft position.

Section 7.2 presents basic data on the landing gear footprint configuration and tire sizes. Also shown are maximum ramp weights and corresponding tire pressures. Main gear tire pressures are based on the maximum permissible aft C.G. and nose gear pressures are based on a nominal C.G. position.

Section 7.3 lists maximum vertical and horizontal pavement loads at the tire ground interfaces for certain critical conditions. The number of struts per airplane is indicated by parentheses where this information is significant.

Section 7.4 provides charts which show static loads imposed on the main landing gear struts for the operational limits of the airplane. These main landing gear loads are used for the interpretation of the pavement design charts which follow.

Section 7.5 presents a pavement requirement chart for flexible pavements. Flexible pavement design curves are based upon the format and procedures set forth in Instruction Report No. S-77-1, "Procedures for Development of CBR Design Curves," published in June 1977 by the U.S. Army Engineer Waterways Experiment Station, Soils and Pavements Laboratory, Vicksburg, Mississippi.

Section 7.6 consists of LCN conversion curves for flexible pavements. These LCN curves have been plotted using procedures and curves in the International Civil Aviation Organization (ICAO) Aerodrome Design Manual, Part 3, "Pavements," Document 9157-AN/901, 1977 Edition.

Section 7.7 provides rigid pavement design curves prepared with the use of the Westergaard Equations in general accordance with the relationships outlined in the 1955 edition of "Design of Concrete Airport Pavement" published by the Portland Cement Association, 33 W. Grand Ave., Chicago 10, Illinois, but modified to the new format described in the 1968 Portland Cement Association publication, "Computer Program for Airport Pavement Design" by Robert G. Packard. The following procedure is used to develop the rigid pavement design curves.

1. Having established the scale for pavement thickness to the left and the scale for allowable working stress to the right, an arbitrary load line is drawn representing the main landing gear maximum weight to be shown.
2. All values of the subgrade modulus (K-values) are then plotted using the maximum load line, as shown.
3. Additional load lines for the incremental value of weight on the main landing gear are then established on the basis of the curve for $K = 300$ PCI, already established.

Section 7.8 presents LCN conversion curves for rigid pavements. These curves have been plotted using procedures and curves in the International Civil Aviation Organization (ICAO) Aerodrome Design Manual, Part 3, "Pavements," Document 9157-AN/901, 1977 Edition. The LCN requirements are based on the condition of center of slab loading. Radius of relative stiffness values are obtained from Section 7.8.1.

On the same charts showing LCN versus equivalent single wheel load, there are load plots for airplane Model DC-9 showing equivalent single wheel load versus pavement thickness for flexible pavements and versus radius of relative stiffness for rigid pavements.

Procedures and curves provided in the ICAO Aerodrome Design Manual are used to determine equivalent single wheel loads for use in making LCN conversion of rigid pavement requirements.

It should be noted that pavement requirements are presented for loads, tires, and tire pressures presently certified for commercial usage. All curves represent data at a constant specified tire pressure.

Section 7.9 provides ACN data prepared according to the ACN-PCN system described in "Aerodromes, Annex 14 to the Convention on International Civil Aviation, Amendment 35."

ACN-PCN provides a standardized international airplane/pavement rating system replacing the various S, T, TT, LCN, AUW, ISWL, etc., rating systems used throughout the world. ACN is the Aircraft Classification Number and PCN is the corresponding Pavement Classification Number. An aircraft having an ACN equal to or less than the PCN can operate without restriction on the pavement. Numerically, the ACN is two times the derived single wheel load expressed in thousands of kilograms, where the derived single wheel load is defined as the load on a single tire inflated to 1.25 MPa (181 psi) that would have the same pavement requirements as the aircraft. Computationally, the ACN-PCN system uses PCA programs PDILB for rigid pavements and S-77-1 for flexible pavements to calculate ACN values. The method of pavement evaluation is the responsibility of the airport with the results of their evaluation presented as follows:

REPORT EXAMPLE: PCN 80/R/B/W/T

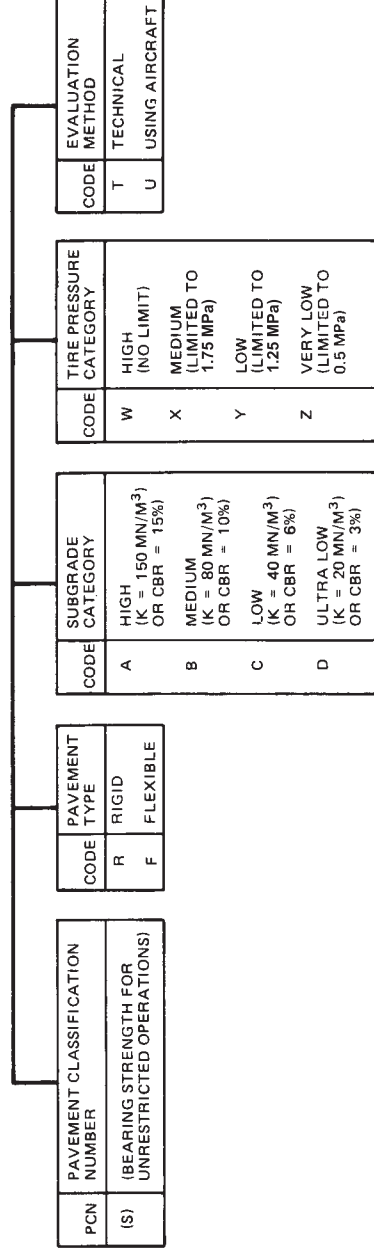

MODEL DC-9					
	-15	-21	-32	-41	-51
MAXIMUM RAMP WEIGHT	91,500 LB (41,504 KG)	101,000 LB (45,813 KG)	109,000 LB (49,442 KG)	115,000 LB (52,163 KG)	122,000 LB (55,338 KG)
PERCENT OF WEIGHT ON MAIN GEAR	SEE SECTION 7.4				
NOSE TIRE SIZE	26 x 6.6 TYPE VII	26 x 6.6 TYPE VII	26 x 6.6 TYPE VII	26 x 6.6 TYPE VII	26 x 6.6 TYPE VII
NOSE TIRE PRESSURE	118 PSI (8.3 KG/CM ²)	131 PSI (9.2 KG/CM ²)	140 PSI (9.9 KG/CM ²)	148 PSI (10.4 KG/CM ²)	157 PSI (11.0 KG/CM ²)
MAIN GEAR TIRE SIZE	40 x 14-16 20 PR	40 x 14-16 22 PR	40 x 14-16 24 PR	41 x 15-18 24 PR	41 x 15-18 24 PR
MAIN GEAR TIRE PRESSURE	130 PSI (9.1 KG/CM ²)	143 PSI (10.1 KG/CM ²)	155 PSI (10.9 KG/CM ²)	160 PSI (11.3 KG/CM ²)	172 PSI (12.1 KG/CM ²)

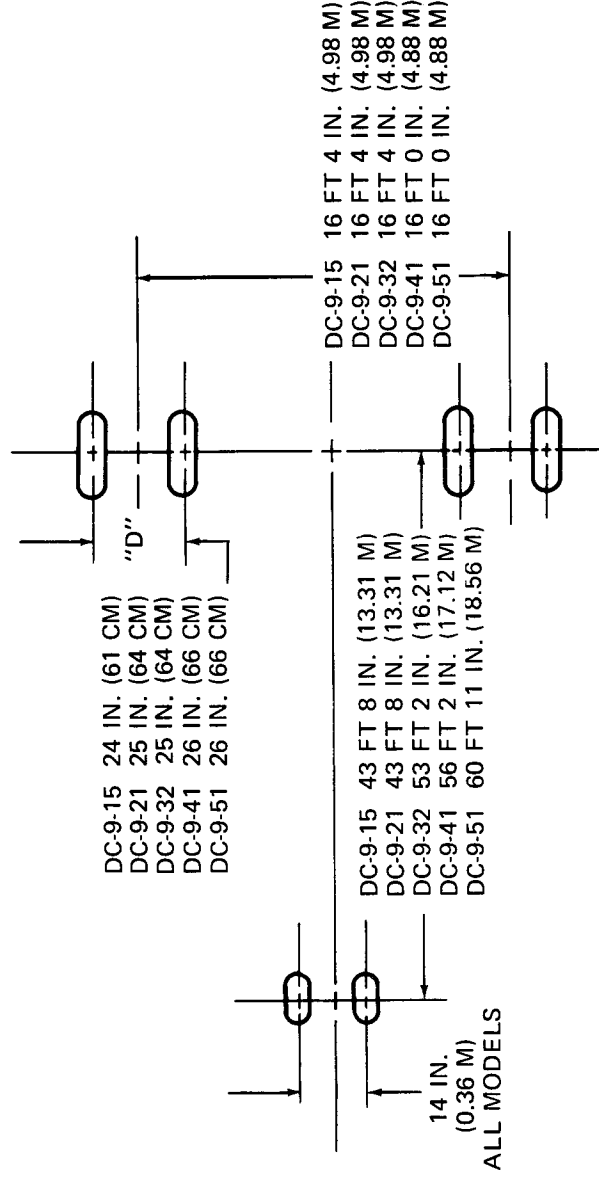

7.2 FOOTPRINT MODEL DC-9

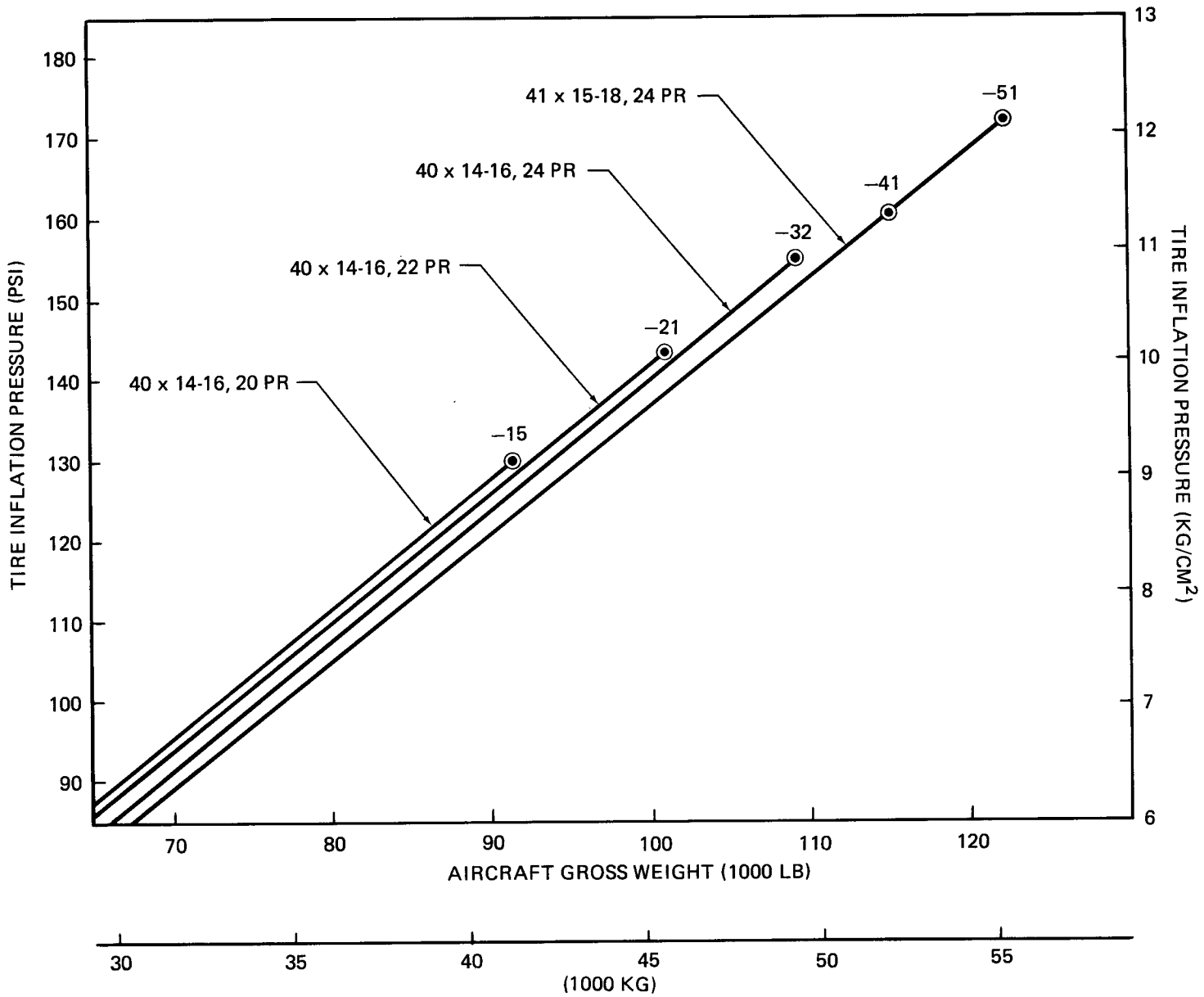

7.2.1 TIRE INFLATION CHART – MODELS DC-9-15, -21, -32, -41, -51

LEGEND: V_{NG} = MAXIMUM VERTICAL NOSE GEAR GROUND LOAD AT MOST FORWARD C.G.
 V_{MG} = MAXIMUM VERTICAL MAIN GEAR GROUND LOAD AT MOST AFT C.G.
H = MAXIMUM HORIZONTAL GROUND LOAD FROM BRAKING

NOTE: ALL LOADS CALCULATED USING
AIRPLANE MAXIMUM GROSS WEIGHT

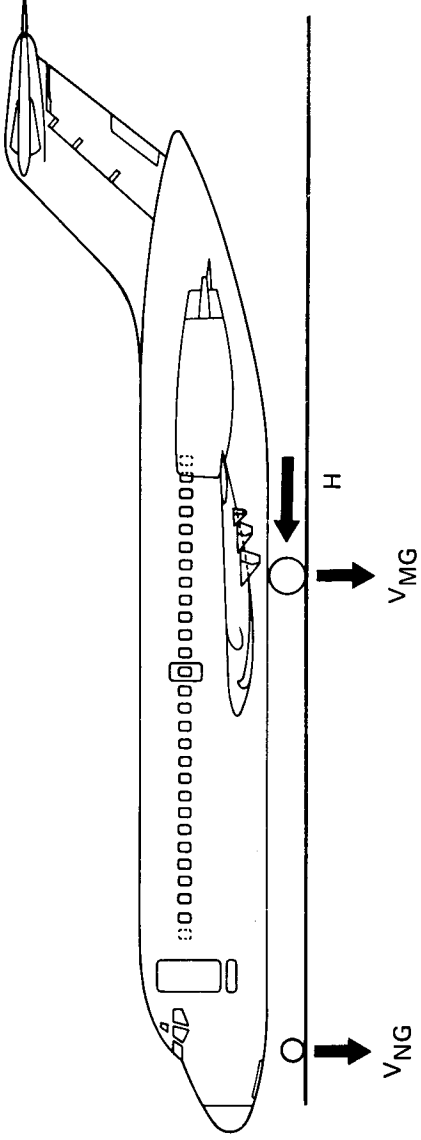

MODEL DC-9	MAXIMUM GROSS WEIGHT		V_{NG} FORWARD CG				V_{MG} PER STRUT (2), AFT CG		H PER STRUT (2)			
	LB	KG	STATIC		STEADY BRAKING*		STATIC		INSTANTANEOUS BRAKING (COEFF OF FRICTION 0.8)		STEADY BRAKING*	
	LB	KG	LB	KG	LB	KG	LB	KG	LB	KG	LB	KG
-15	91,500	4,012	8,844	4,012	14,810	6,718	42,439	19,250	29,069	13,185	14,208	6,445
-21	101,000	5,190	11,443	5,190	18,028	8,177	47,648	21,613	32,637	14,804	15,683	7,114
-32	109,000	5,206	11,477	5,206	17,313	7,853	50,360	22,843	35,405	16,059	16,925	7,678
-41	115,000	5,167	11,391	5,167	17,220	7,811	53,817	24,411	38,062	17,265	17,857	8,101
-51	122,000	5,340	11,773	5,340	16,549	7,506	57,303	25,992	41,645	18,890	18,944	8,594

*10 FT/SEC² DECELERATION DUE ONLY TO BRAKING

7.3 MAXIMUM PAVEMENT LOADS MODEL DC-9

NOTE: UNSHADED AREAS REPRESENT OPERATIONAL LIMITS

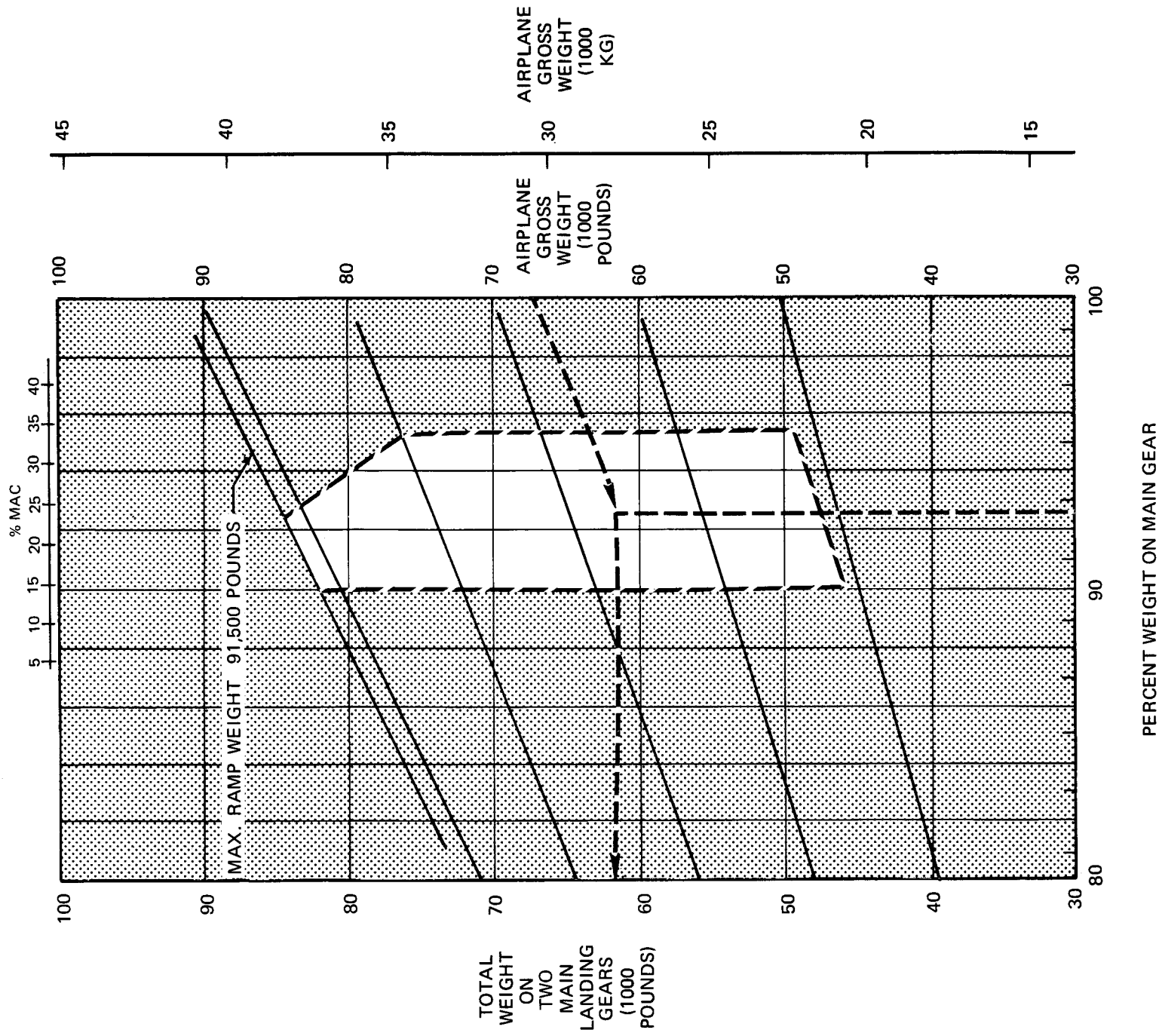

7.4 LANDING GEAR LOADING ON PAVEMENT MODEL DC-9-15

NOTE: UNSHADED AREAS REPRESENT OPERATIONAL LIMITS

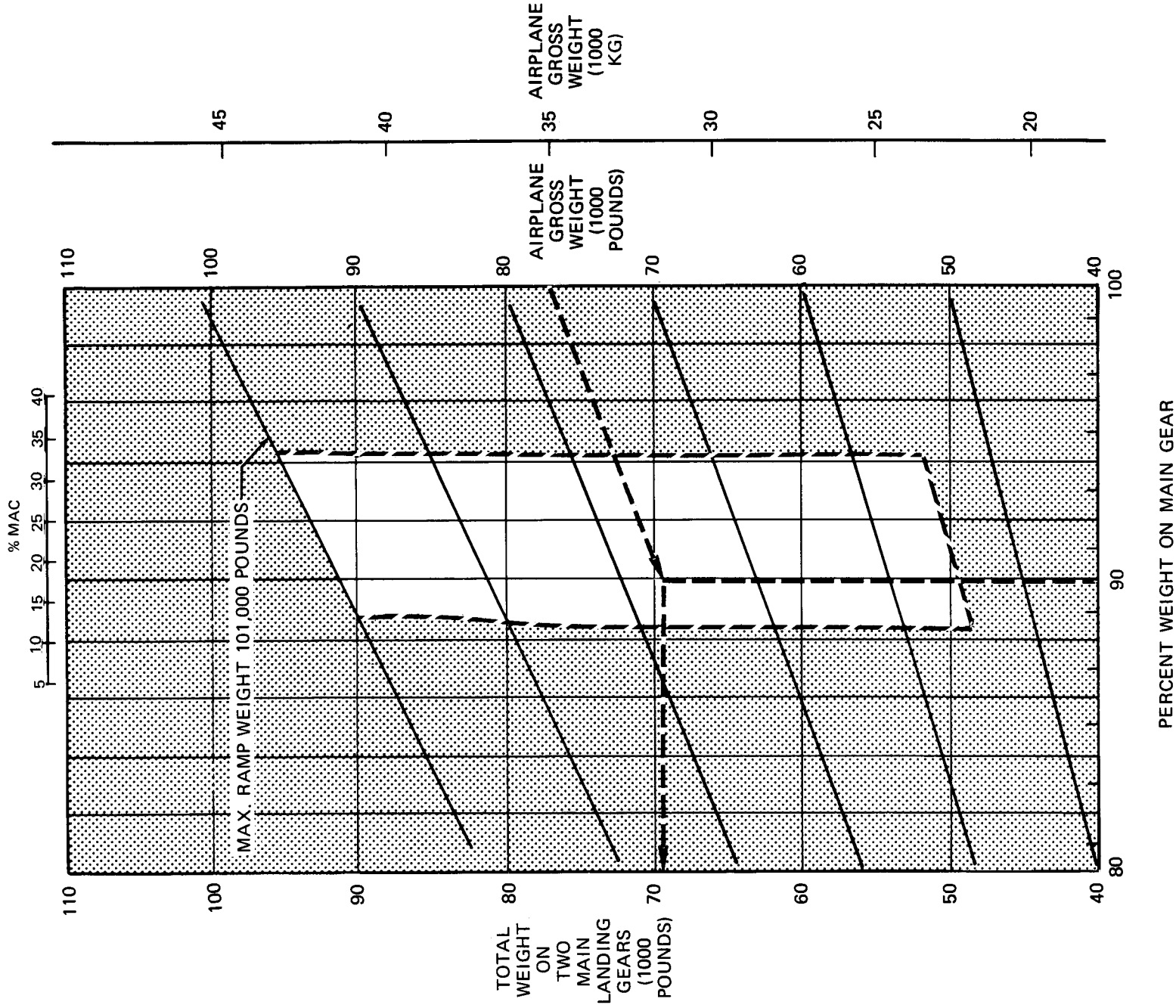

7.4 LANDING GEAR LOADING ON PAVEMENT MODEL DC-9-21

NOTE: UNSHADED AREAS REPRESENT OPERATIONAL LIMITS

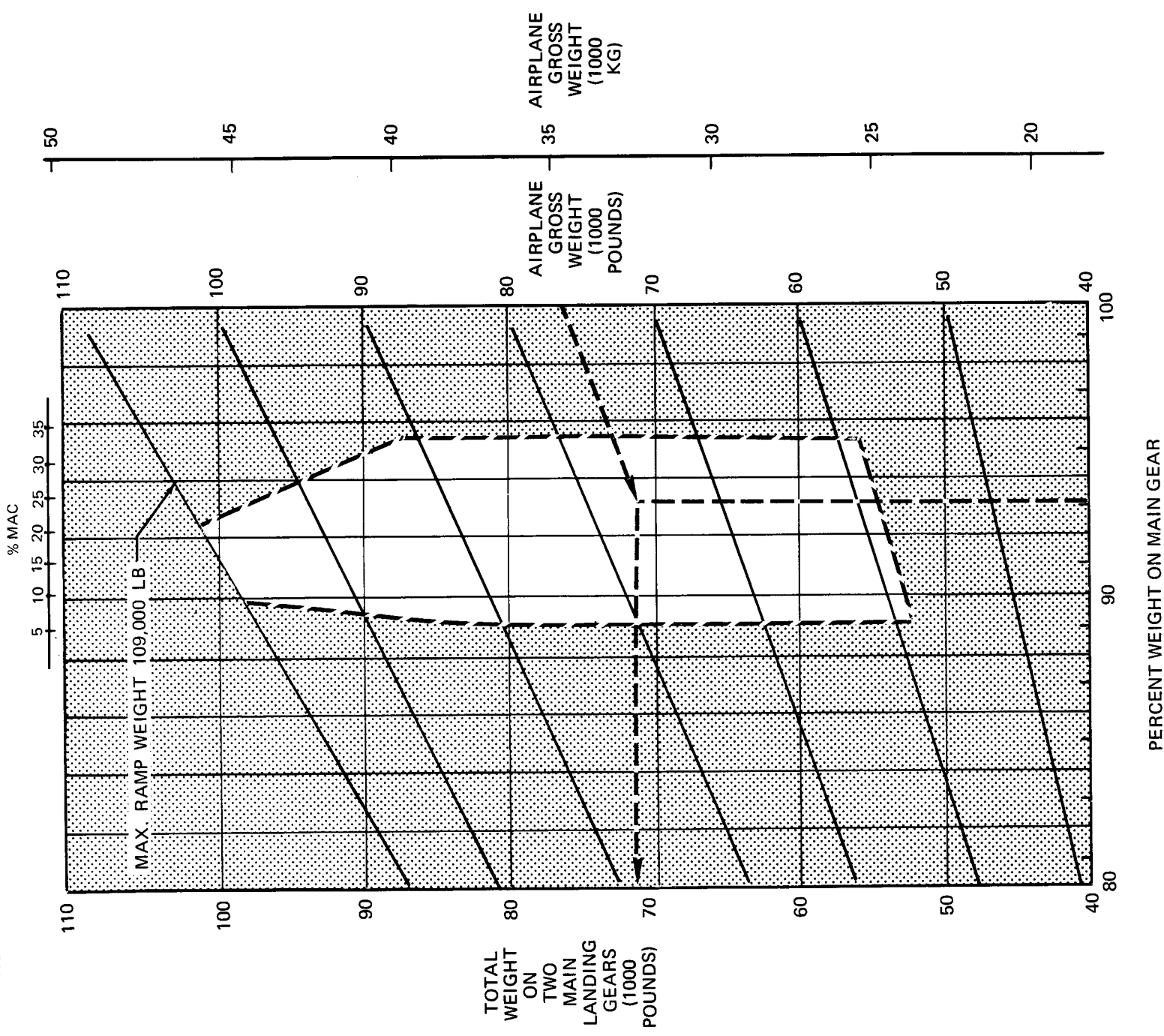

7.4 LANDING GEAR LOADING ON PAVEMENT MODEL DC-9-32

NOTE: UNSHADED AREAS REPRESENT OPERATIONAL LIMITS

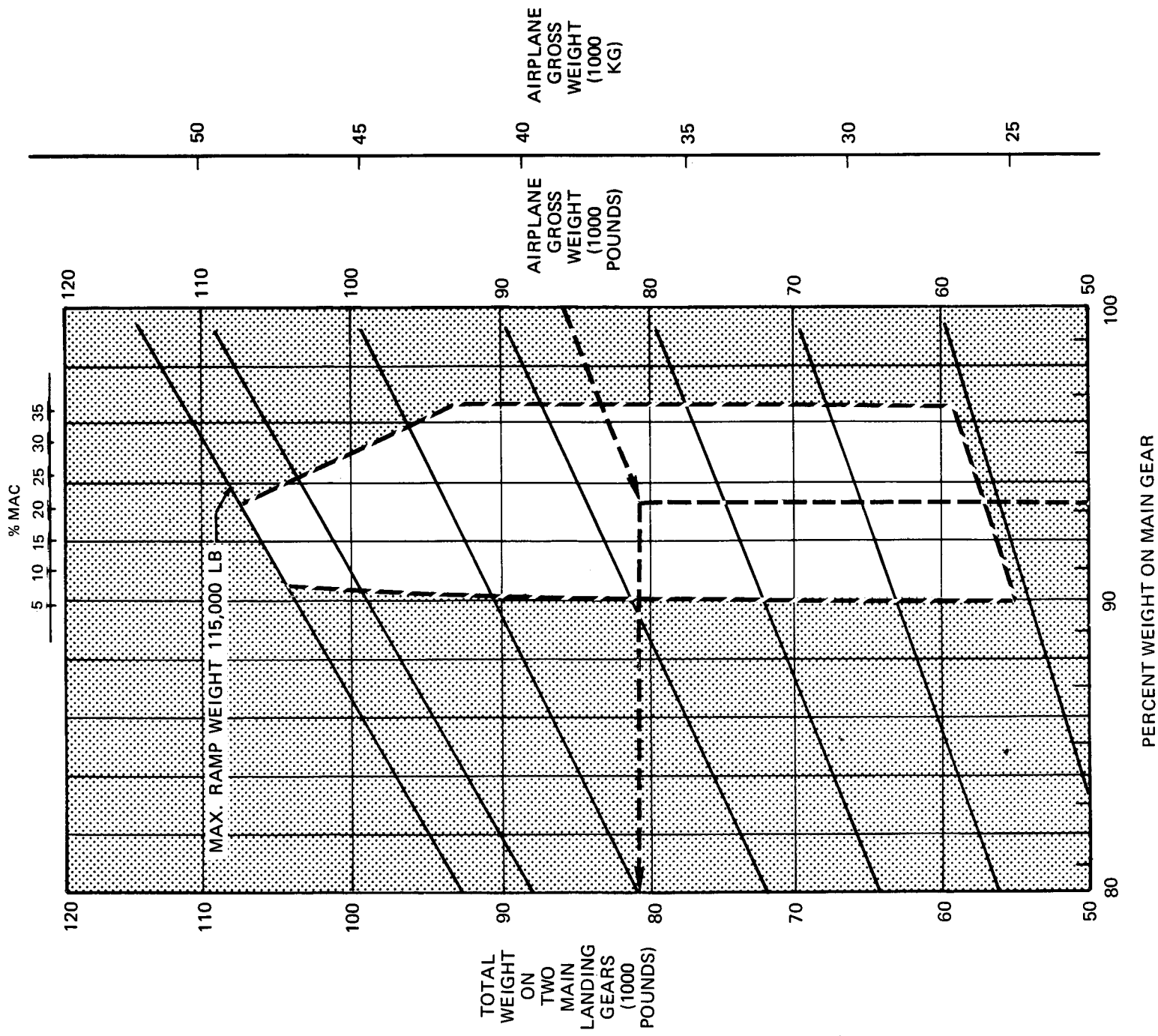

7.4 LANDING GEAR LOADING ON PAVEMENT MODEL DC-9-41

NOTE: UNSHADED AREAS REPRESENT OPERATIONAL LIMITS

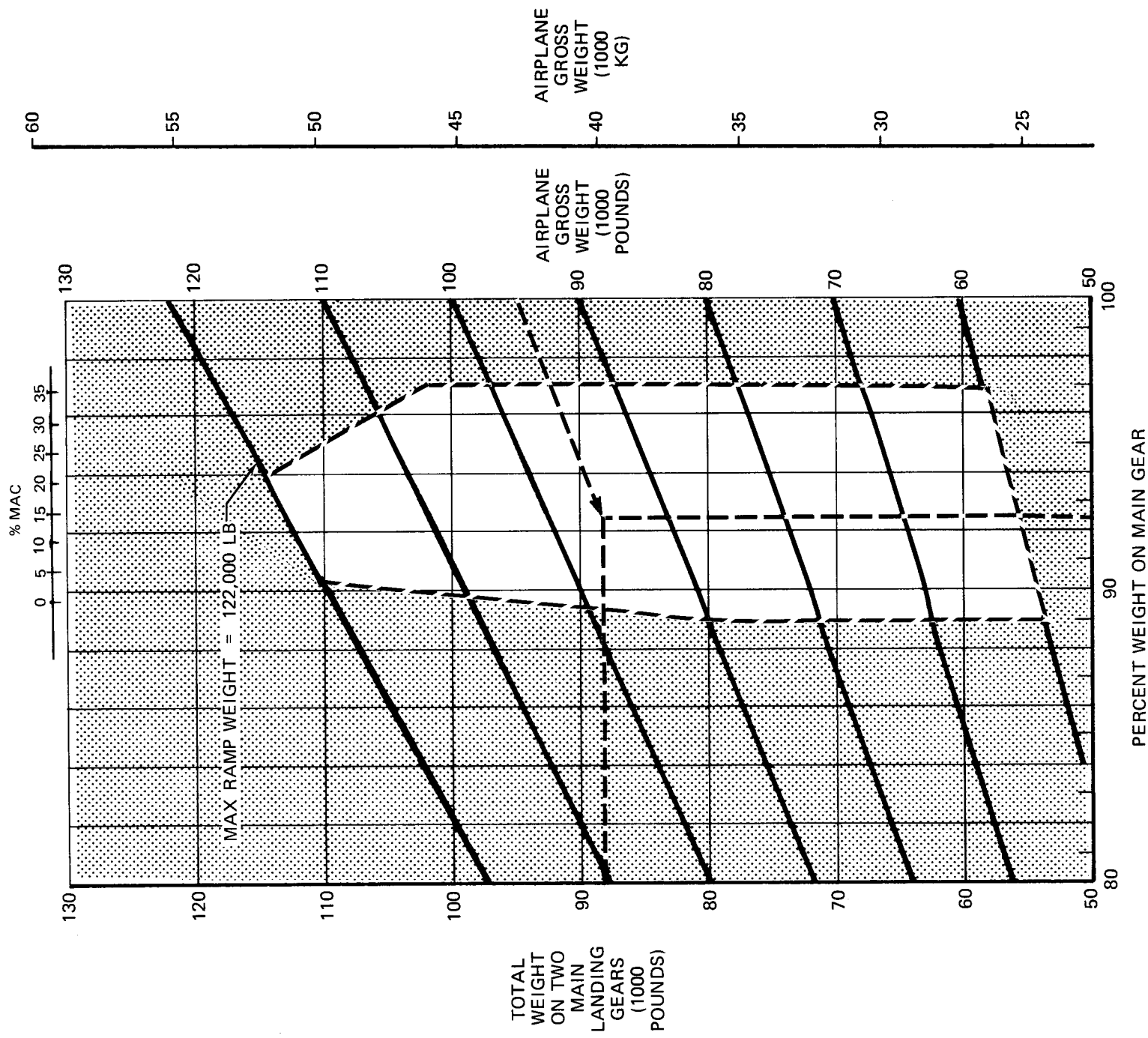

7.4 LANDING GEAR LOADING ON PAVEMENT MODEL DC-9-51

7.5 Flexible Pavement Requirements – U.S. Army Corps of Engineers Method (S-77-1)

The flexible pavement design chart is prepared for standard-pressure tires. This chart presents the data for incremental maingear weights as well as the maximum ramp weight of each model.

In the example shown on the next page, for a CBR of 7.0 and an annual departure level of 6000, the required flexible pavement thickness for an airplane with a maingear loading of 70,000 pounds is 20.0 inches.

The line showing 10,000 coverages is used for ACN calculations.

40 x 14-16 AND 41 x 15-18 TIRES
TIRE PRESSURE RANGE: 130 TO 172 PSI

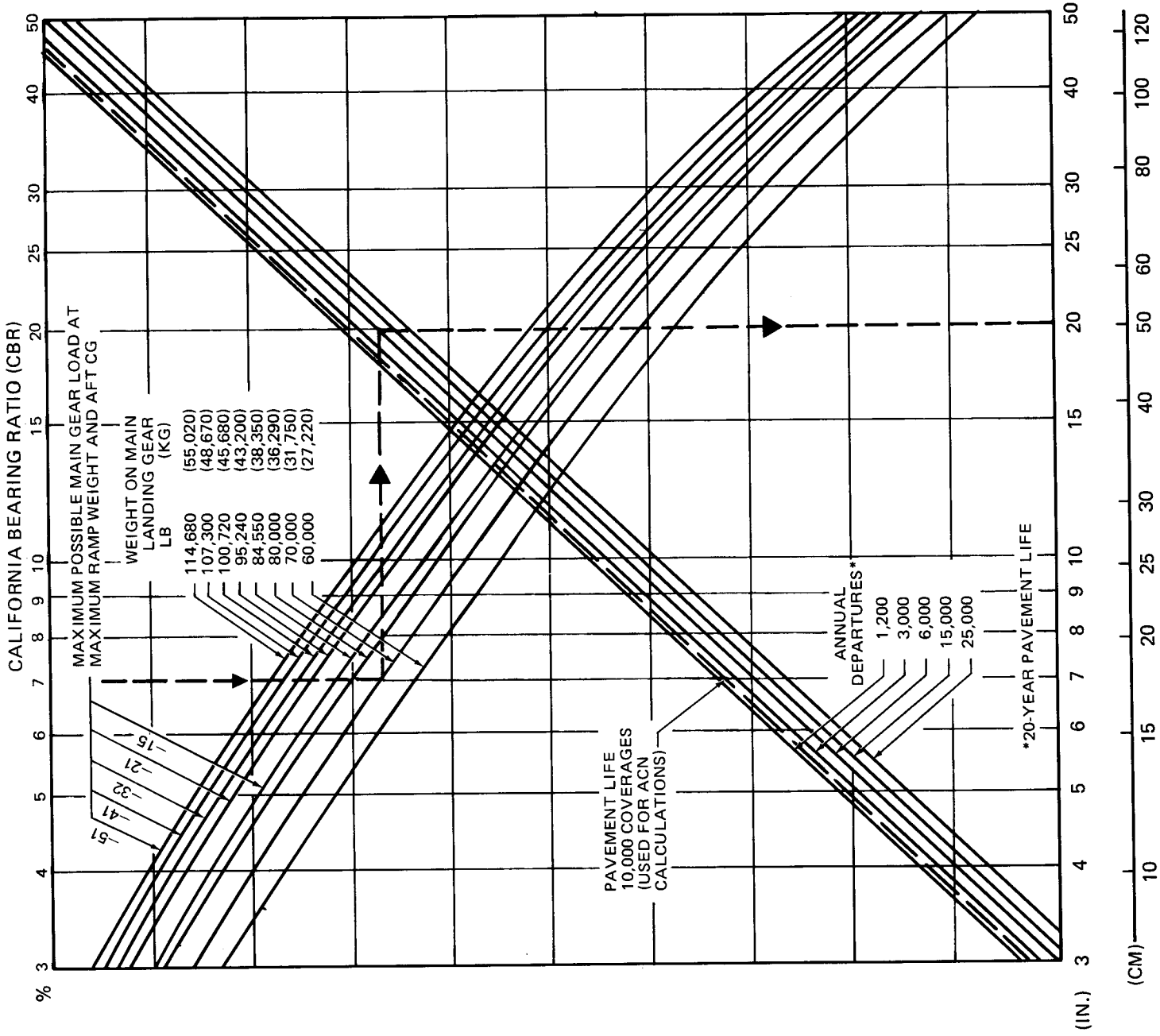

**7.5 FLEXIBLE PAVEMENT REQUIREMENTS –
U.S. ARMY CORPS OF ENGINEERS DESIGN
METHOD (S-77-1)**

MODELS DC-9-15, -21, -32, -41, -51

7.6 Flexible Pavement Requirements, LCN Conversion

In order to determine the airplane weight that can be accommodated on a particular flexible airport pavement, both the LCN of the pavement and the thickness (h) of the pavement must be known.

In the example for the Model DC-9-15, the flexible pavement thickness is 25 inches and the LCN is 39. For these conditions, the weight on the main landing gear is 75,000 pounds.

Note: If the resultant aircraft LCN is not more than 10 percent above the published pavement LCN, it is the United Kingdom's view that the bearing strength of the pavement can be considered sufficient for unlimited use by the airplane. The figure of 10 percent has been chosen as representing the lowest degree of variation in LCN that is significant. (Reference: ICAO Aerodrome Design Manual, Paragraph 3.5.2, 1977 Edition.)

NOTE: EQUIVALENT SINGLE WHEEL LOADS ARE DERIVED BY METHODS SHOWN IN ICAO AERODROME MANUAL.

40 x 14 TIRES – TIRE PRESSURE CONSTANT AT 130 PSI (9.1 KG/CM²)

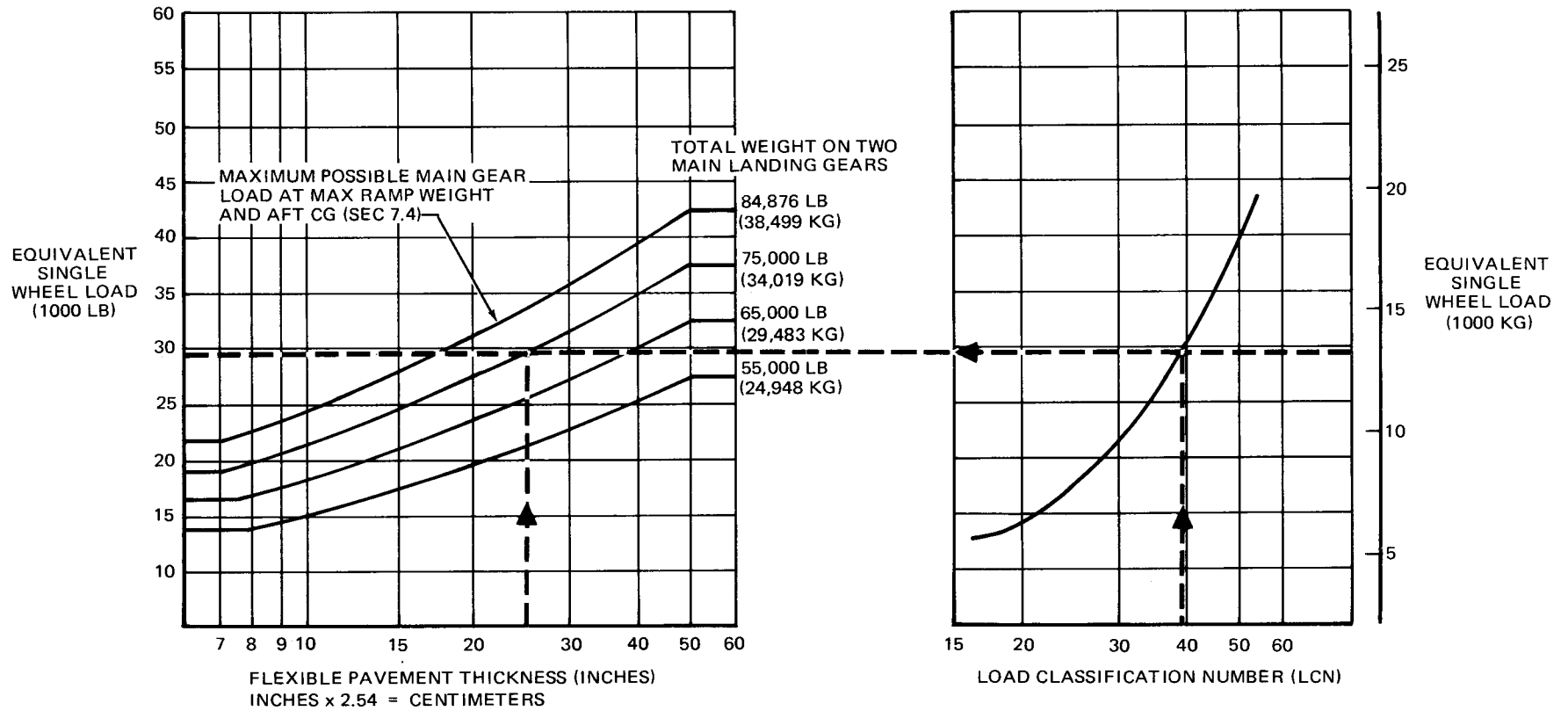

7.6 FLEXIBLE PAVEMENT REQUIREMENTS – LCN CONVERSION MODEL DC-9-15

NOTE: EQUIVALENT SINGLE WHEEL LOADS ARE DERIVED BY METHODS SHOWN IN ICAO AERODROME MANUAL.

40 x 14 TIRES – TIRE PRESSURE CONSTANT AT 143 PSI (10.1 KG/CM²)

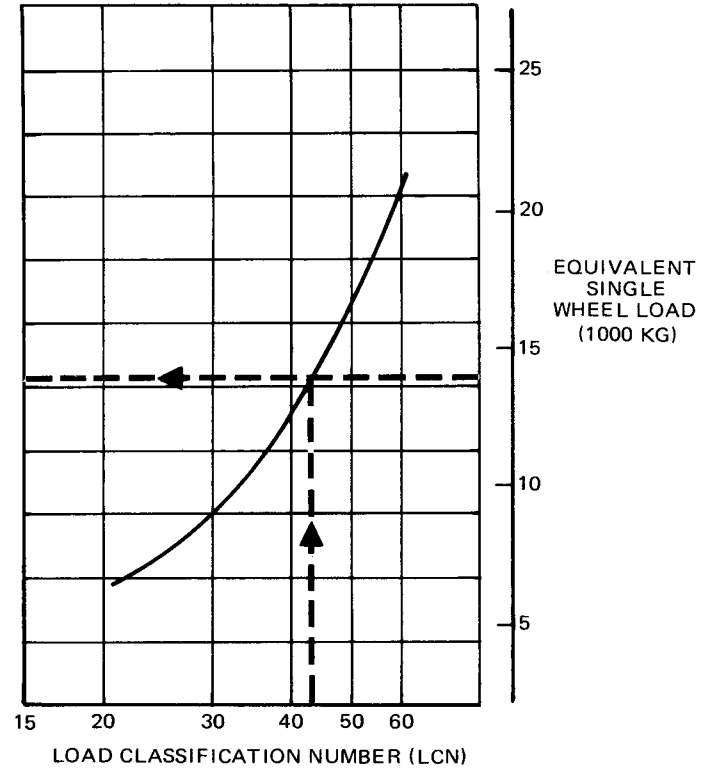
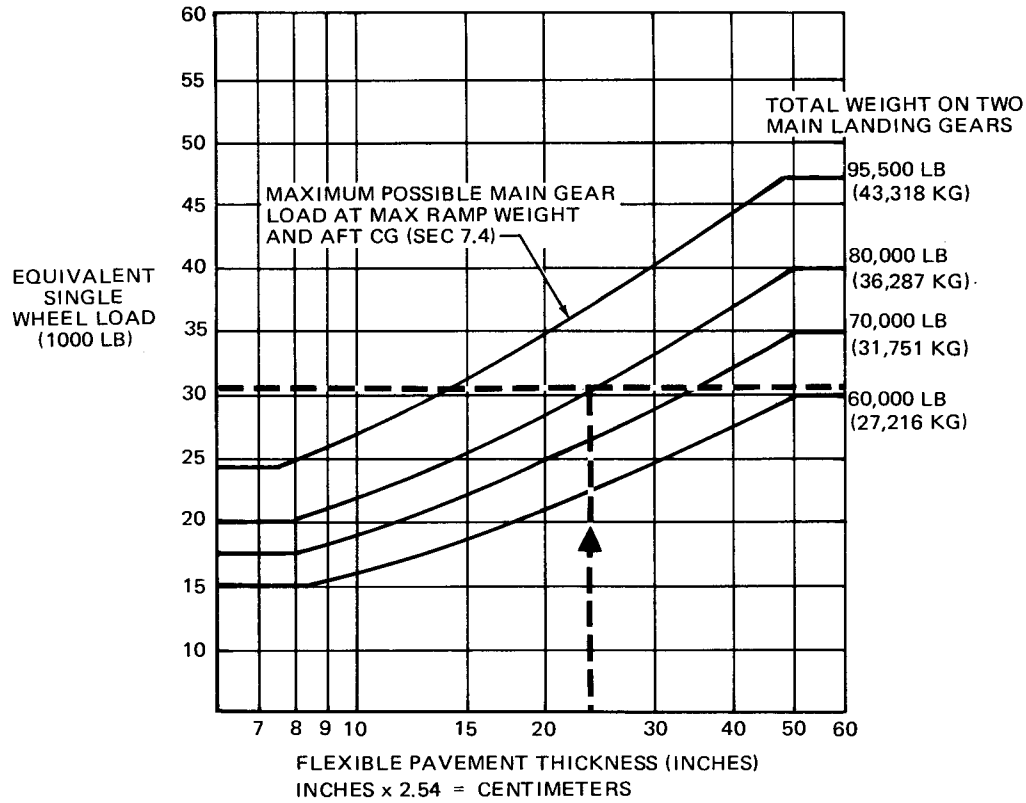

7.6 FLEXIBLE PAVEMENT REQUIREMENTS – LCN CONVERSION MODEL DC-9-21

NOTE: EQUIVALENT SINGLE WHEEL LOADS ARE DERIVED BY METHODS SHOWN IN ICAO AERODROME MANUAL.

40 x 14 TIRES – TIRE PRESSURE CONSTANT AT 155 PSI (10.9 KG/CM²)

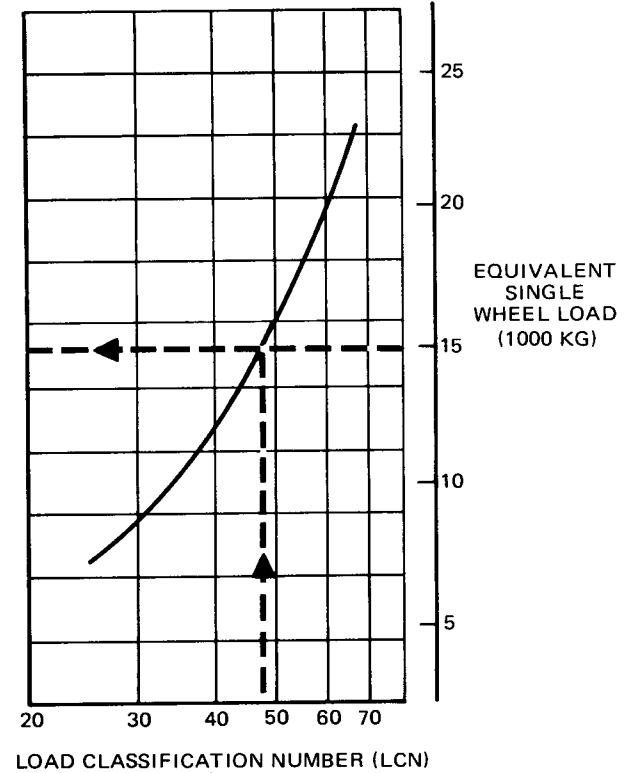
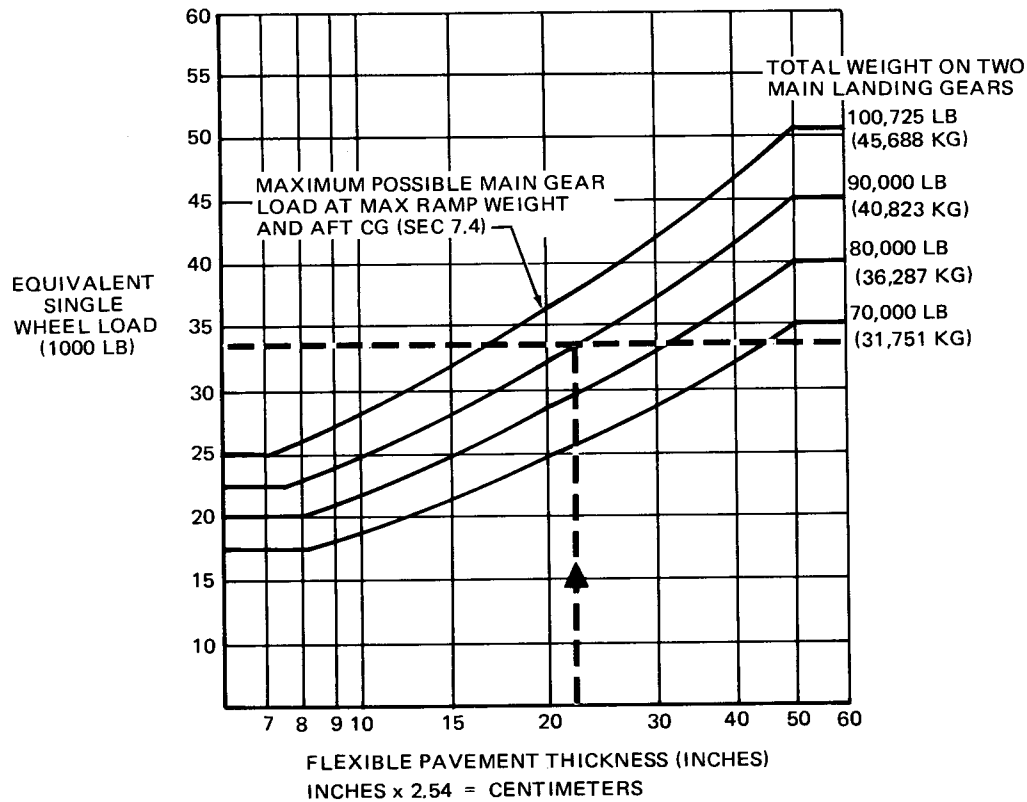

7.6 FLEXIBLE PAVEMENT REQUIREMENTS – LCN CONVERSION MODEL DC-9-32

NOTE: EQUIVALENT SINGLE WHEEL LOADS ARE DERIVED BY METHODS SHOWN IN ICAO AERODROME MANUAL, I

41 x 15 TIRES – TIRE PRESSURE CONSTANT AT 160 PSI (11.3 KG/CM²)

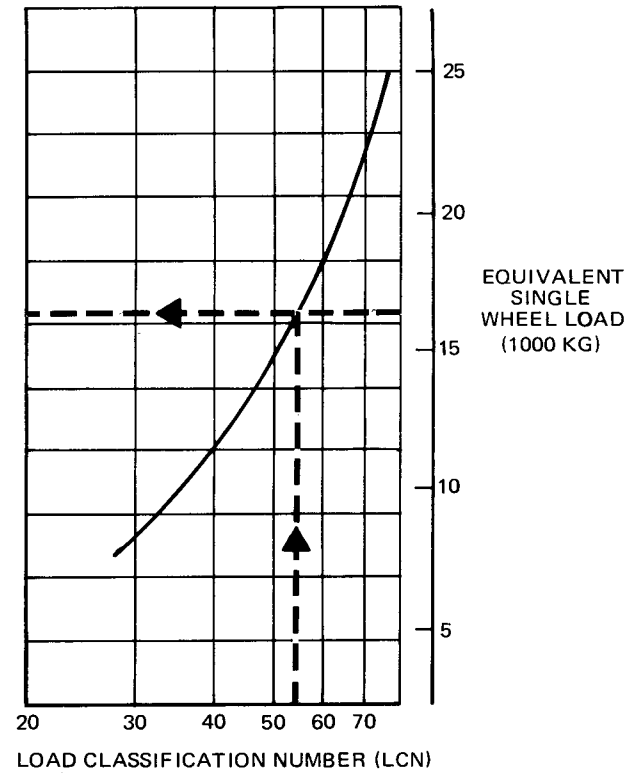
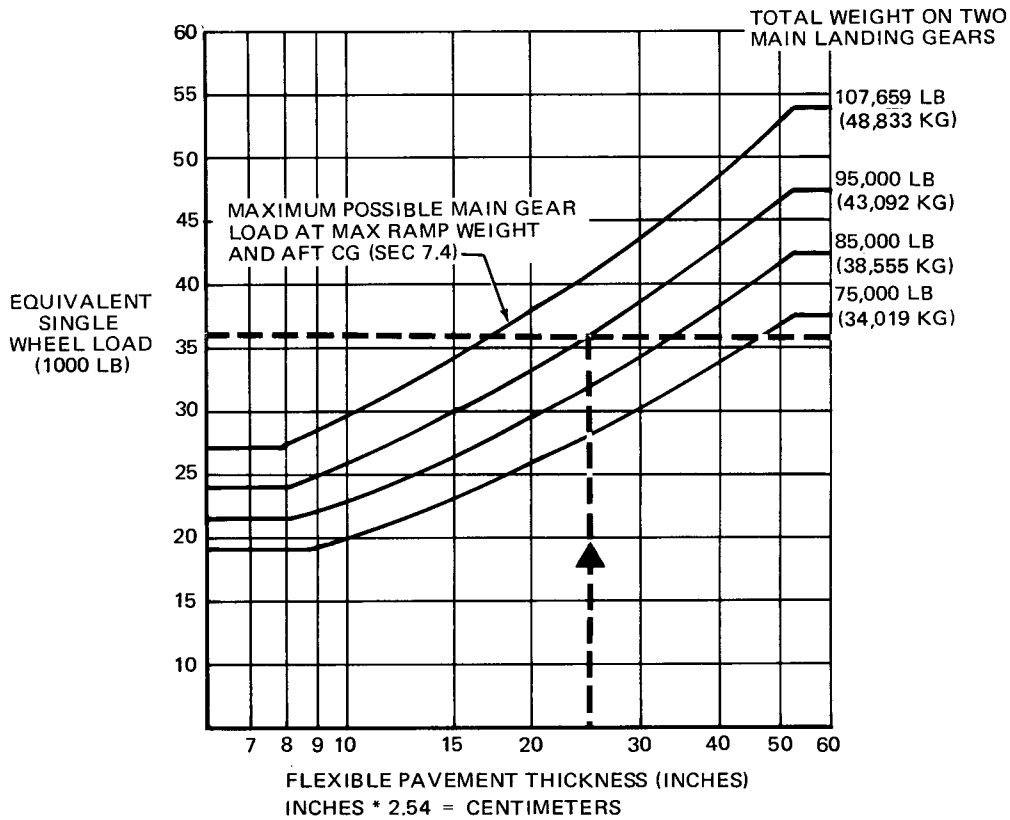

7.6 FLEXIBLE PAVEMENT REQUIREMENTS – LCN CONVERSION MODEL DC-9-41

NOTE: EQUIVALENT SINGLE WHEEL LOADS ARE DERIVED BY METHODS SHOWN IN ICAO AERODROME MANUAL.

41 x 15 TIRES – TIRE PRESSURE CONSTANT AT 172 PSI (12.1 KG/CM²)

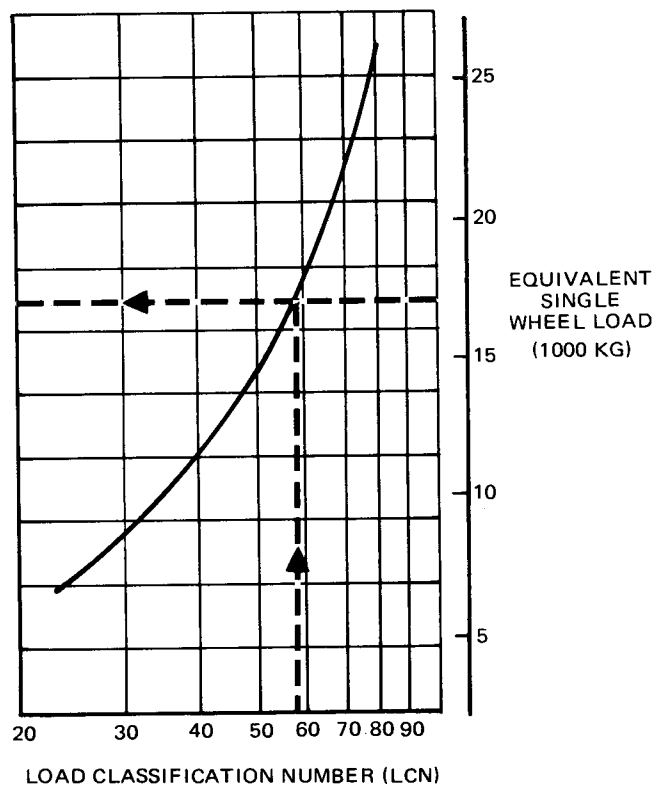
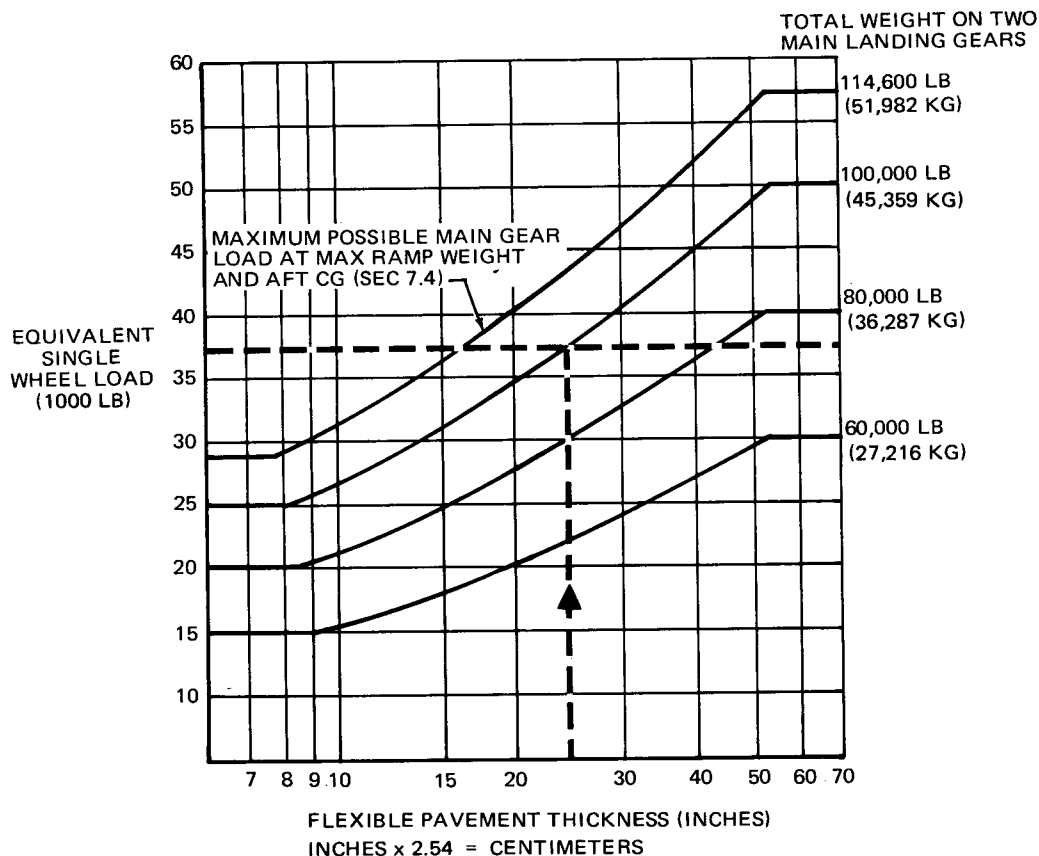

7.6 FLEXIBLE PAVEMENT REQUIREMENTS – LCN CONVERSION MODEL DC-9-51

7.7 Rigid Pavement Requirements, Portland Cement Association Design Method

In order to determine the airplane weight that can be accommodated on a particular rigid pavement, the thickness (h) of the pavement, the subgrade modulus (k) and the allowable working stress must be known.

In the example for the Model DC-9-15, the rigid pavement thickness is 8 inches, the subgrade modulus is 300, and the allowable working stress is 476 psi. For these conditions, the weight on the main landing gear is 84,880 pounds.

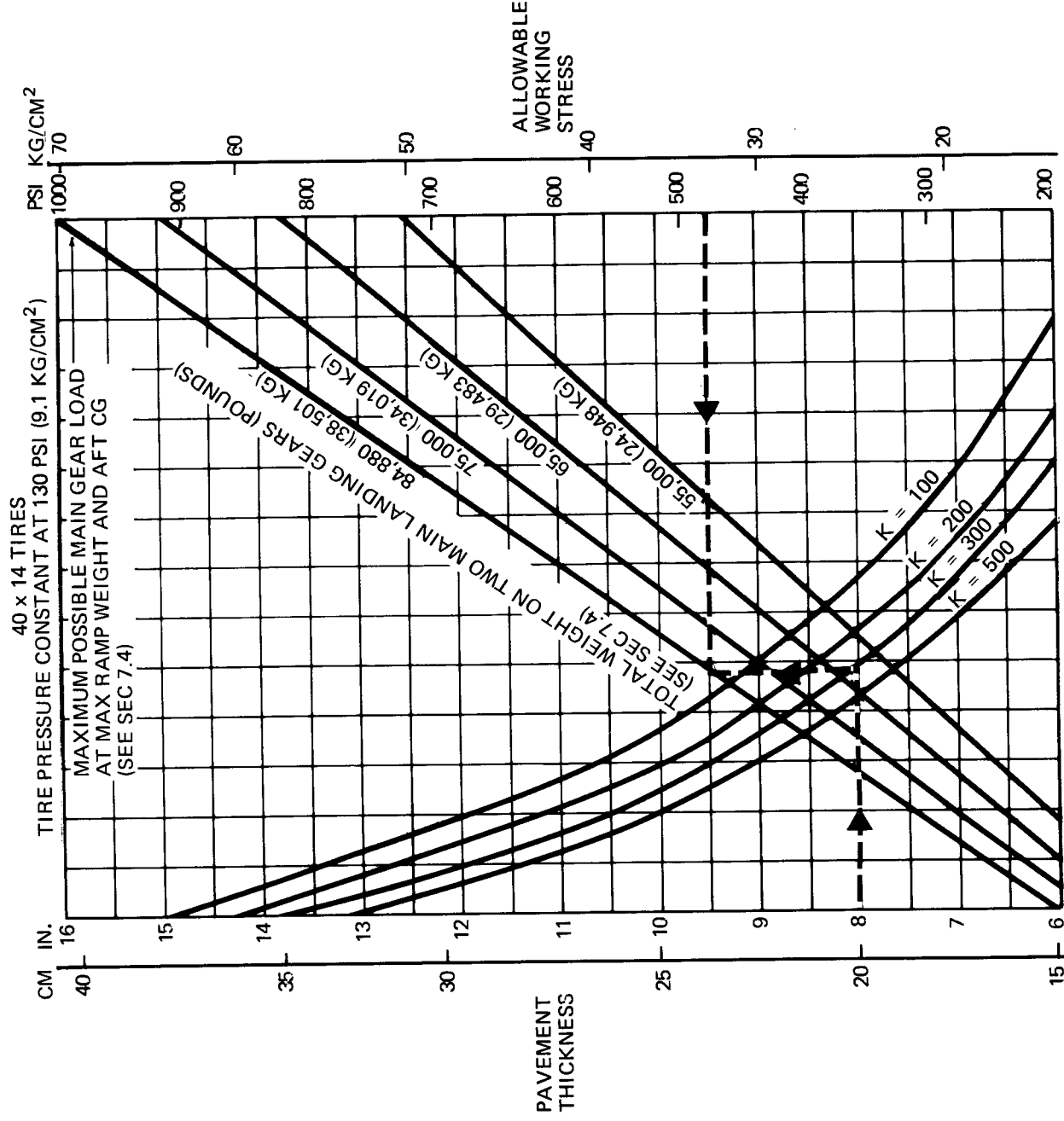

NOTE: THE VALUES OBTAINED BY USING THE MAXIMUM LOAD REFERENCE LINE AND ANY VALUE OF K ARE EXACT. FOR LOADS LESS THAN MAXIMUM, THE CURVES ARE EXACT FOR K = 300, BUT DEVIATE SLIGHTLY FOR OTHER VALUES OF K.

REFERENCE: "DESIGN OF CONCRETE AIRPORT PAVEMENT" AND COMPUTER PROGRAM FOR PAVEMENT DESIGN," (PROGRAM PDILB) PORTLAND CEMENT ASSOCIATION

7.7 RIGID PAVEMENT REQUIREMENTS, PORTLAND CEMENT ASSOCIATION DESIGN METHOD MODEL DC-9-15

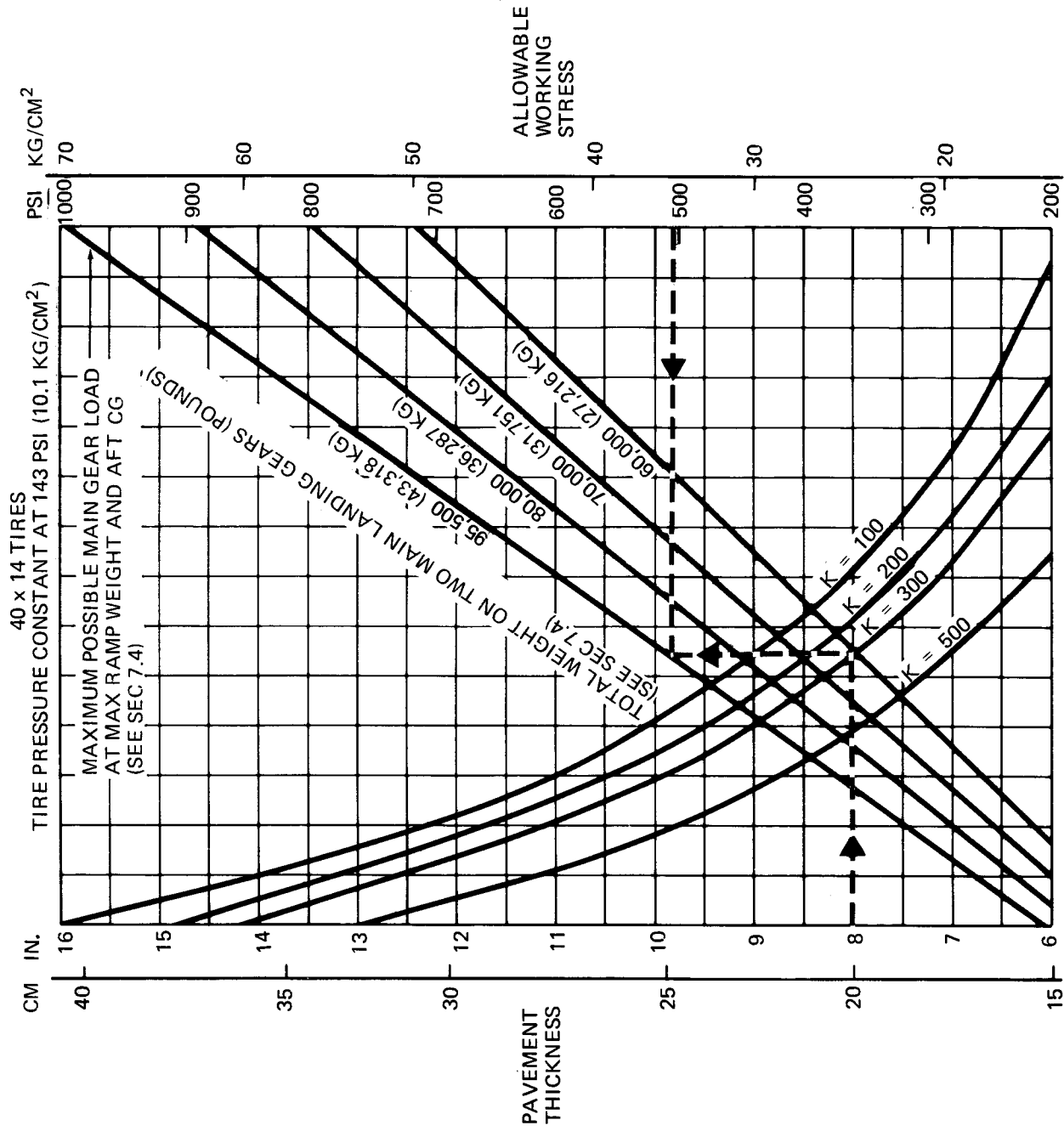

NOTE: THE VALUES OBTAINED BY USING THE MAXIMUM LOAD REFERENCE LINE AND ANY VALUE OF K ARE EXACT. FOR LOADS LESS THAN MAXIMUM, THE CURVES ARE EXACT FOR K = 300, BUT DEVIATE SLIGHTLY FOR OTHER VALUES OF K.

REFERENCE: "DESIGN OF CONCRETE AIRPORT PAVEMENT" AND "COMPUTER PROGRAM FOR PAVEMENT DESIGN," (PROGRAM PDILB) PORTLAND CEMENT ASSOCIATION

7.7 RIGID PAVEMENT REQUIREMENTS, PORTLAND CEMENT ASSOCIATION DESIGN METHOD MODEL DC-9-21

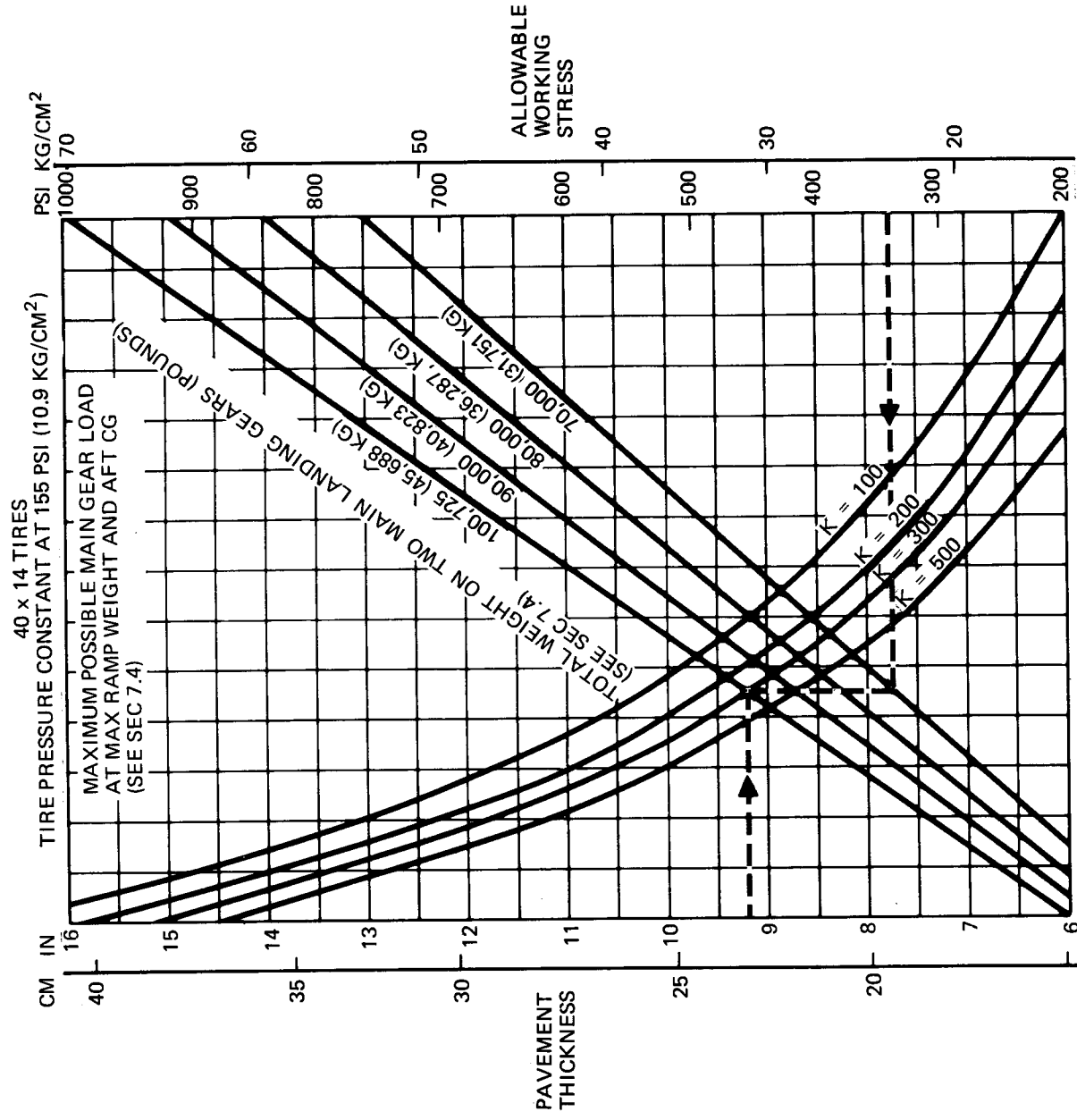

NOTE: THE VALUES OBTAINED BY USING THE MAXIMUM LOAD REFERENCE LINE AND ANY VALUE OF K ARE EXACT. FOR LOADS LESS THAN MAXIMUM, THE CURVES ARE EXACT FOR K = 300, BUT DEVIATE SLIGHTLY FOR OTHER VALUES OF K.

REFERENCE: "DESIGN OF CONCRETE AIRPORT PAVEMENT" AND
COMPUTER PROGRAM FOR PAVEMENT DESIGN,"
(PROGRAM PDILB) PORTLAND CEMENT ASSOCIATION

7.7 RIGID PAVEMENT REQUIREMENTS, PORTLAND CEMENT ASSOCIATION DESIGN METHOD MODEL DC-9-32

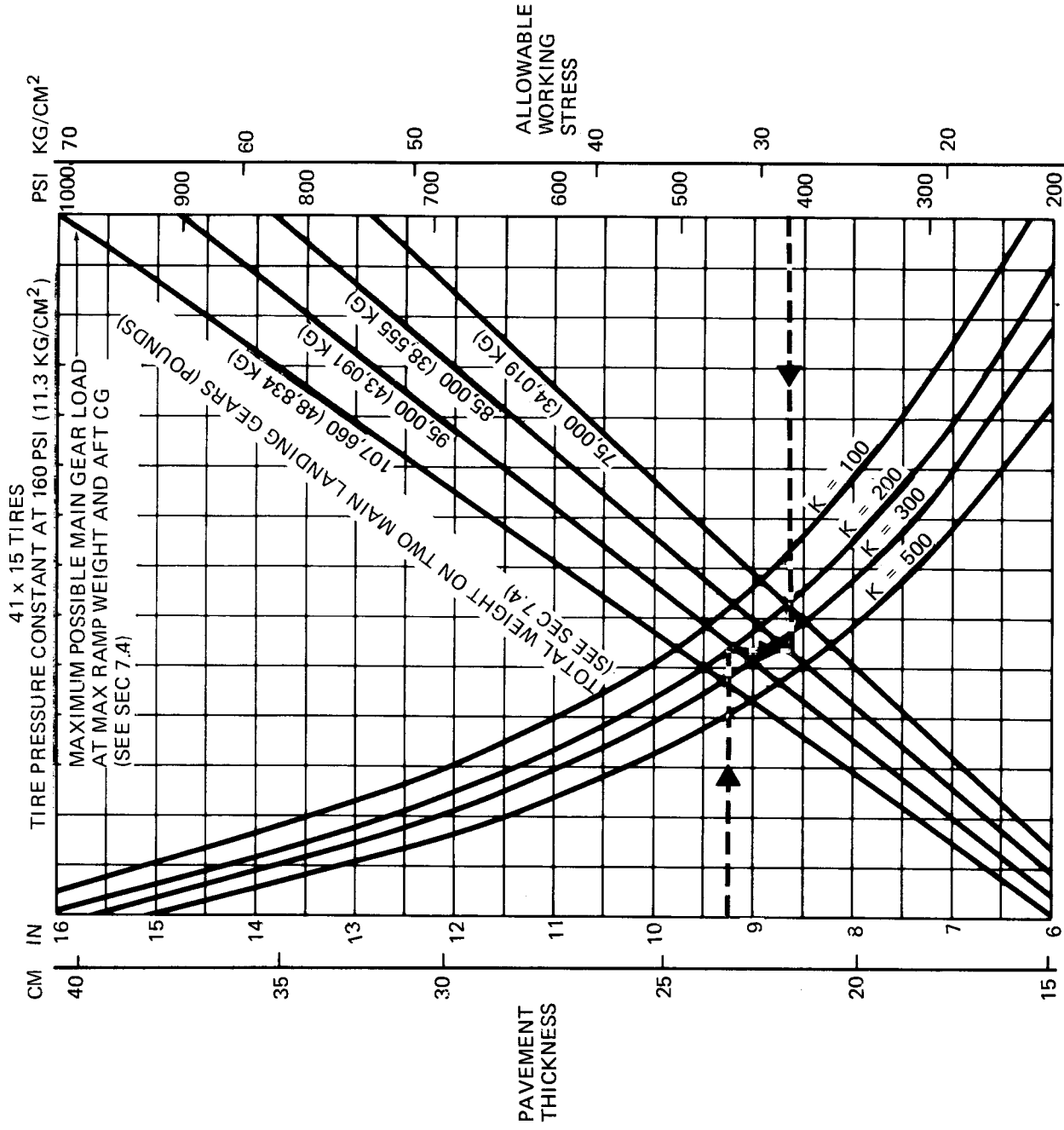

NOTE: THE VALUES OBTAINED BY USING THE MAXIMUM LOAD REFERENCE LINE AND ANY VALUE OF K ARE EXACT. FOR LOADS LESS THAN MAXIMUM, THE CURVES ARE EXACT FOR K = 300, BUT DEVIATE SLIGHTLY FOR OTHER VALUES OF K.

REFERENCE: "DESIGN OF CONCRETE AIRPORT PAVEMENT" AND "COMPUTER PROGRAM FOR PAVEMENT DESIGN," (PROGRAM PDILB) PORTLAND CEMENT ASSOCIATION

7.7 RIGID PAVEMENT REQUIREMENTS, PORTLAND CEMENT ASSOCIATION DESIGN METHOD MODEL DC-9-41

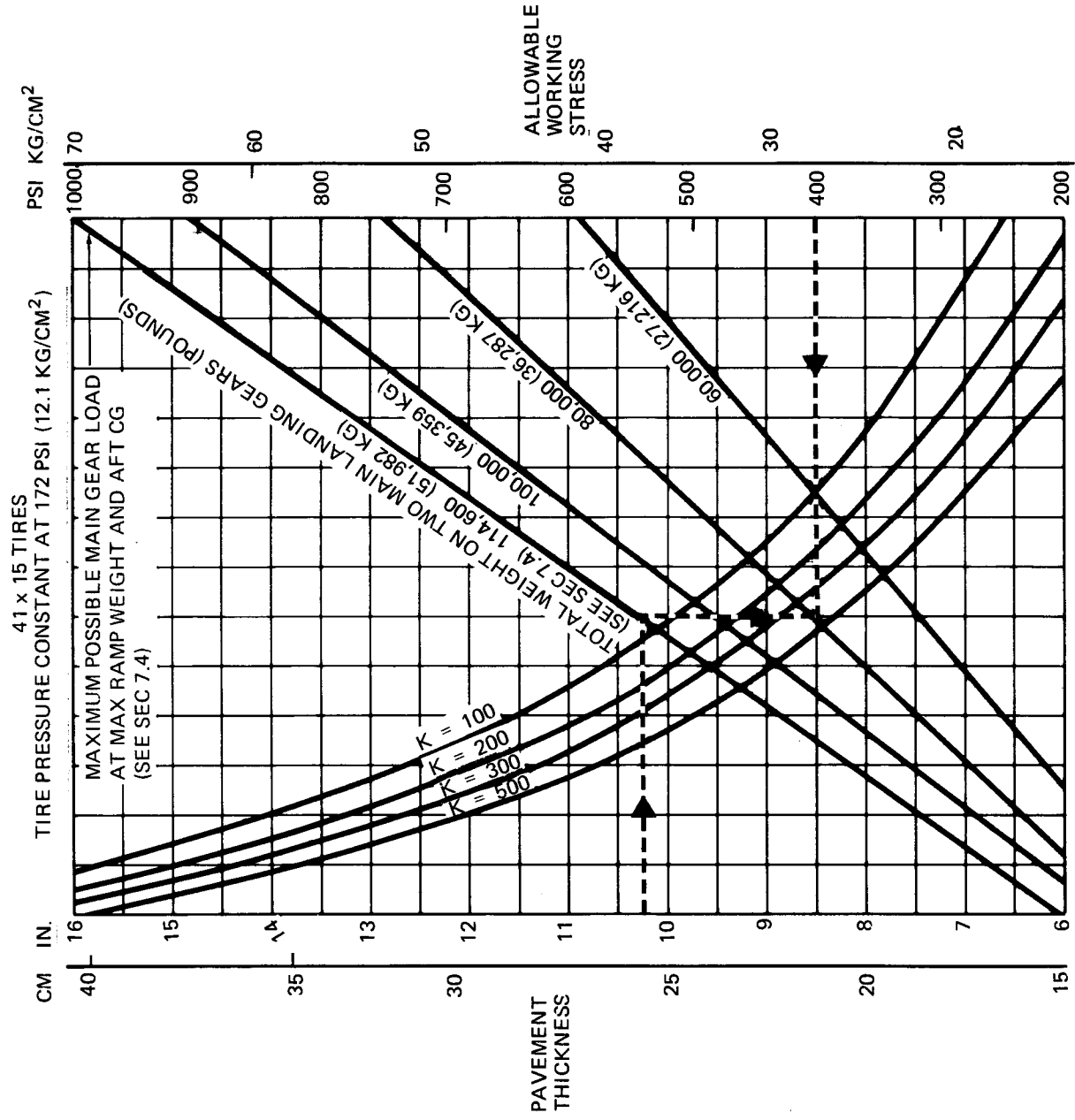

NOTE: THE VALUES OBTAINED BY USING THE MAXIMUM LOAD REFERENCE LINE AND ANY VALUE OF K ARE EXACT FOR LOADS LESS THAN MAXIMUM, THE CURVES ARE EXACT FOR K = 300, BUT DEVIATE SLIGHTLY FOR OTHER VALUES OF K.

REFERENCE: "DESIGN OF CONCRETE AIRPORT PAVEMENT" AND COMPUTER PROGRAM FOR PAVEMENT DESIGN," (PROGRAM PDILB) PORTLAND CEMENT ASSOCIATION

7.7 RIGID PAVEMENT REQUIREMENTS, PORTLAND CEMENT ASSOCIATION DESIGN METHOD MODEL DC-9-51

7.8 Rigid Pavement Requirements, LCN Conversion

In order to determine the airplane weight that can be accommodated on a particular rigid airport pavement, both the LCN of the pavement and the radius of relative stiffness must be known.

In the example for the Model DC-9-15, the rigid pavement radius of relative stiffness is 52 inches, and the LCN is 35. For these conditions, the weight on the main landing gear is 65,000 pounds.

The LCN charts use ℓ -values based on Young's Modulus (E) of 4,000,000 psi and Poisson's Ratio (μ) of 0.15. For convenience in finding ℓ -values based on other values of E and μ , the curves in Subsections 7.8.1 and 7.8.2 are included. For example, to find an ℓ -value based on an E of 3,000,000 psi the "E" factor of 0.931 is multiplied by the ℓ -value found in Table 7.8.1. The effect of variations of " μ " on the ℓ -value is treated in a similar manner.

Note: If the resultant aircraft LCN is not more than 10 percent above the published pavement LCN, it is the United Kingdom's view that the bearing strength of the pavement can be considered sufficient for unlimited use by the airplane. The figure of 10 percent has been chosen as representing the lowest degree of variation in LCN which is significant. (Reference: ICAO Aerodrome Design Manual, Paragraph 3.5.2, 1977 Edition.)

NOTE: EQUIVALENT SINGLE WHEEL LOADS ARE DERIVED BY METHODS SHOWN IN ICAO AERODROME MANUAL,

LCN REQUIREMENTS ARE BASED ON CENTER OF SLAB LOADING

40 x 14 TIRES – TIRE PRESSURE CONSTANT AT 130 PSI (9.1 KG/CM²)

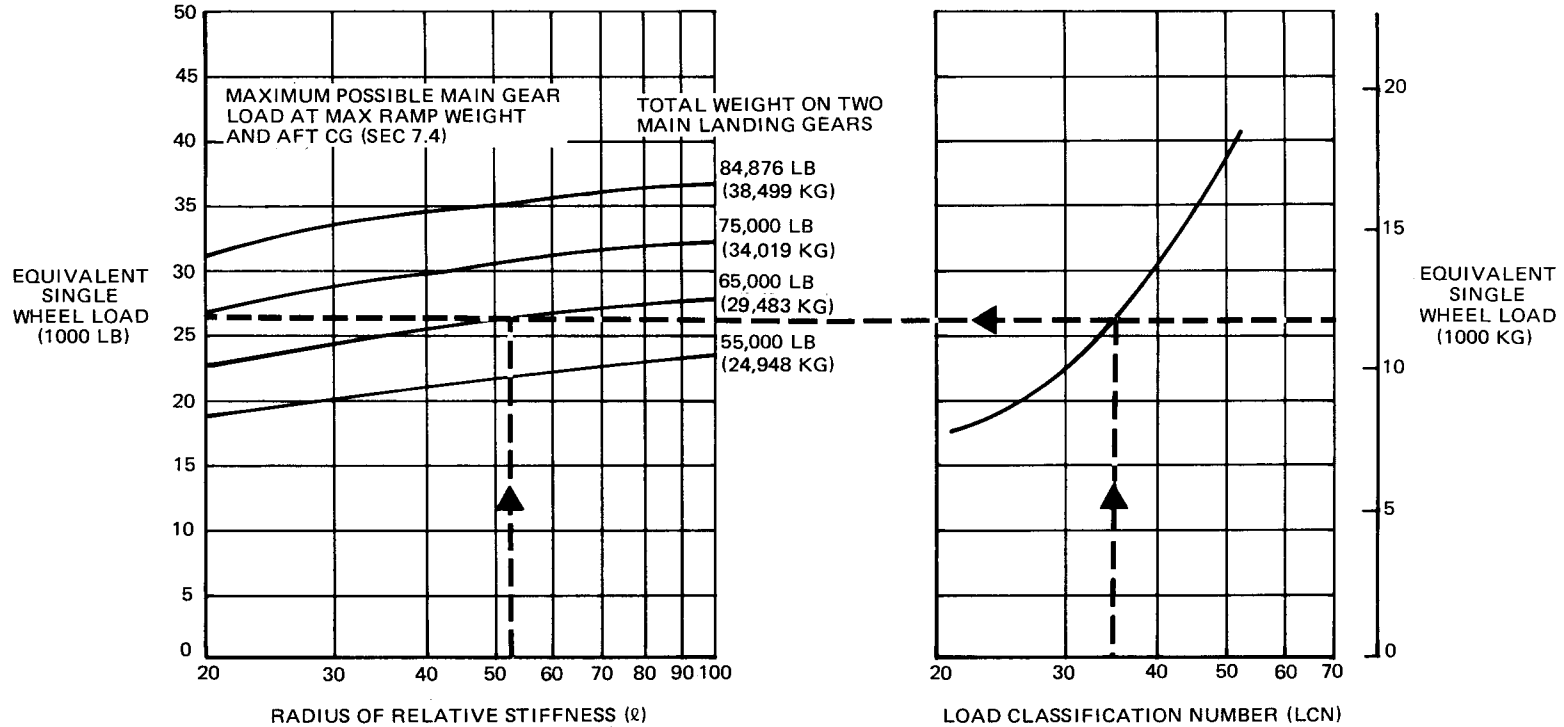

7.8 RIGID PAVEMENT REQUIREMENTS, LCN CONVERSION MODEL DC-9-15

NOTE: EQUIVALENT SINGLE WHEEL LOADS ARE DERIVED BY METHODS SHOWN IN ICAO AERODROME MANUAL.

LCN REQUIREMENTS ARE BASED ON CENTER OF SLAB LOADING

40 x 14 TIRES – TIRE PRESSURE CONSTANT AT 143 PSI (10.1 KG/CM²)

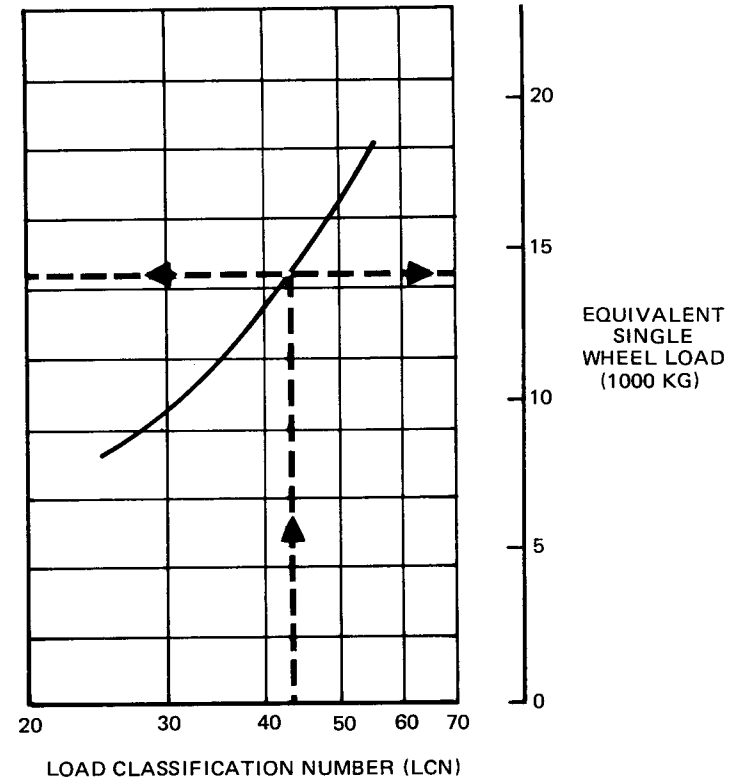
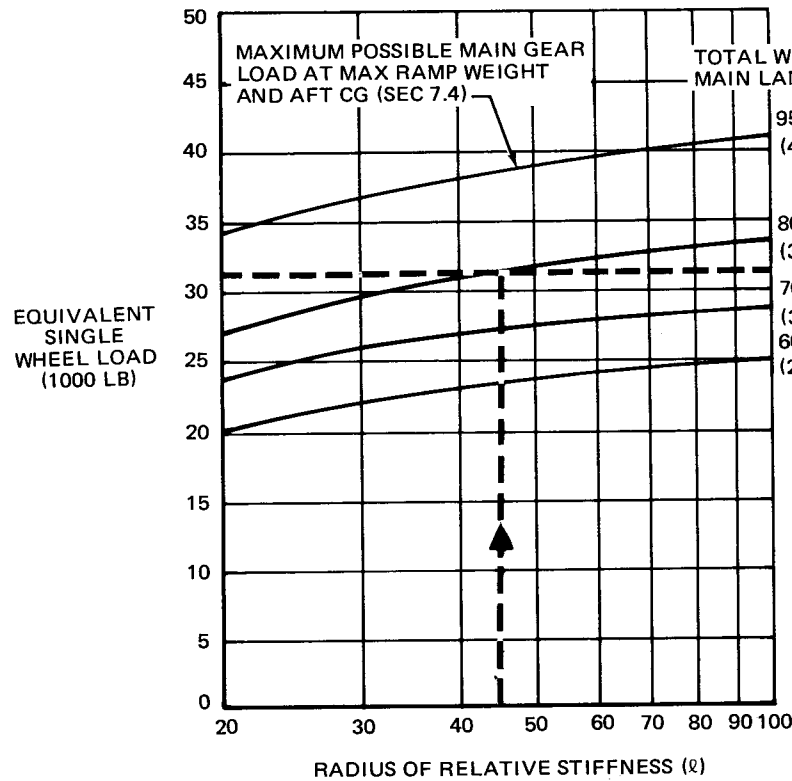

7.8 RIGID PAVEMENT REQUIREMENTS, LCN CONVERSION MODEL DC-9-21

NOTE: EQUIVALENT SINGLE WHEEL LOADS ARE DERIVED BY METHODS SHOWN IN ICAO AERODROME MANUAL.

LCN REQUIREMENTS ARE BASED ON CENTER OF SLAB LOADING

40 x 14 TIRES – TIRE PRESSURE CONSTANT AT 155 PSI (10.9 KG/CM²)

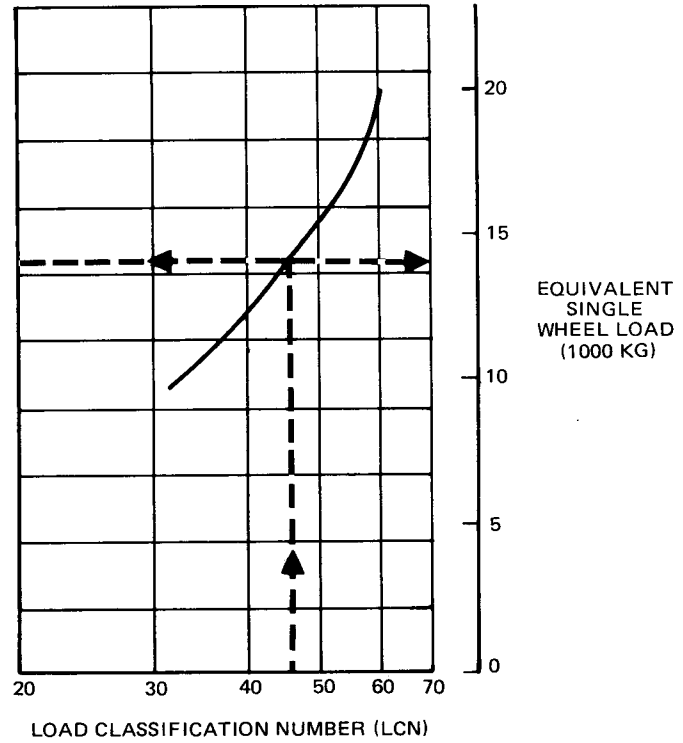
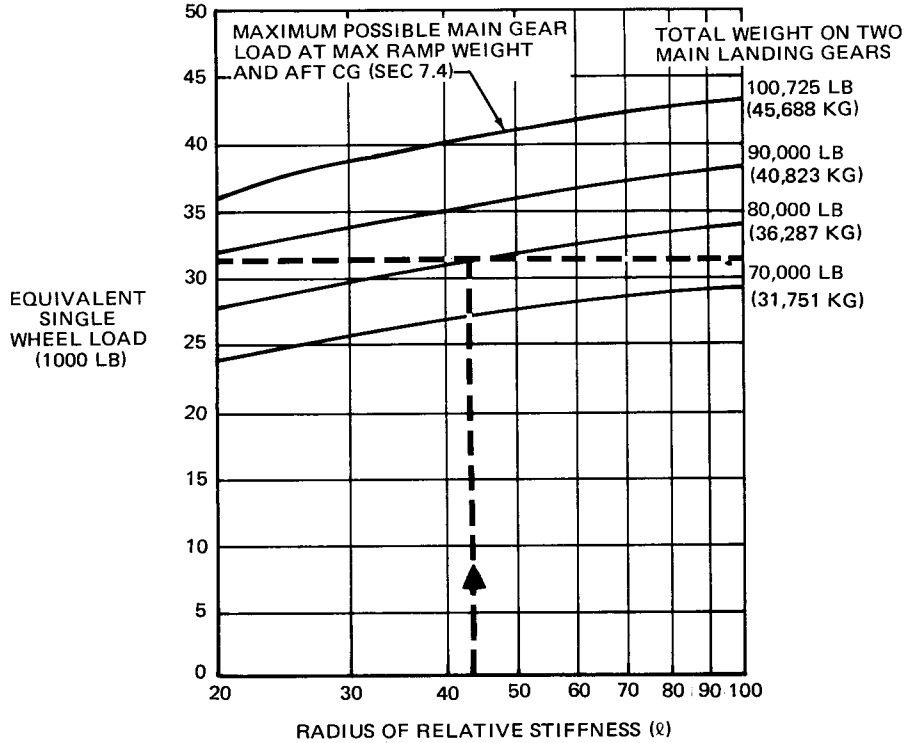

7.8 RIGID PAVEMENT REQUIREMENTS, LCN CONVERSION MODEL DC-9-32

NOTE: EQUIVALENT SINGLE WHEEL LOADS ARE DERIVED BY METHODS SHOWN IN ICAO AERODROME MANUAL.

LCN REQUIREMENTS ARE BASED ON CENTER OF SLAB LOADING

41 x 15 TIRES – TIRE PRESSURE CONSTANT AT 160 PSI (11.3 KG/CM²)

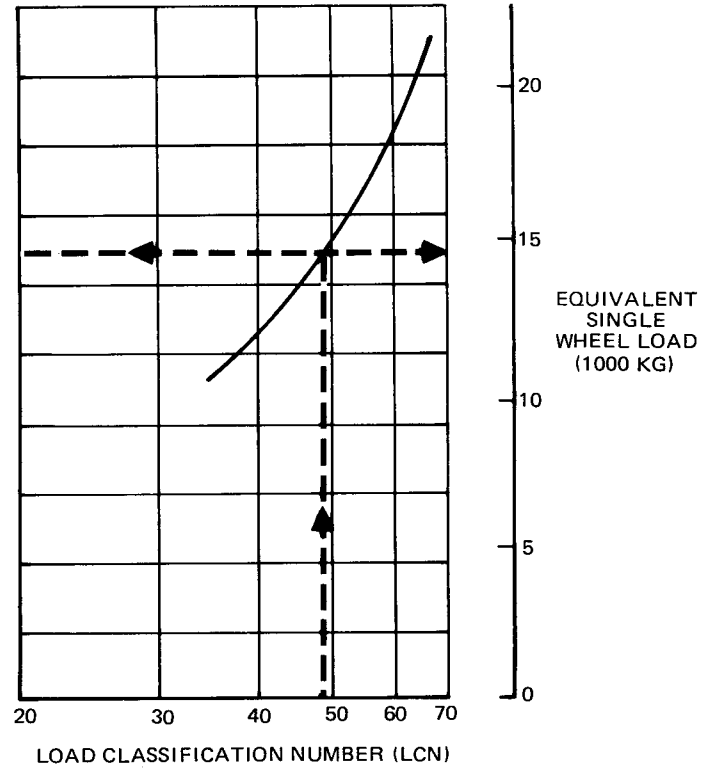
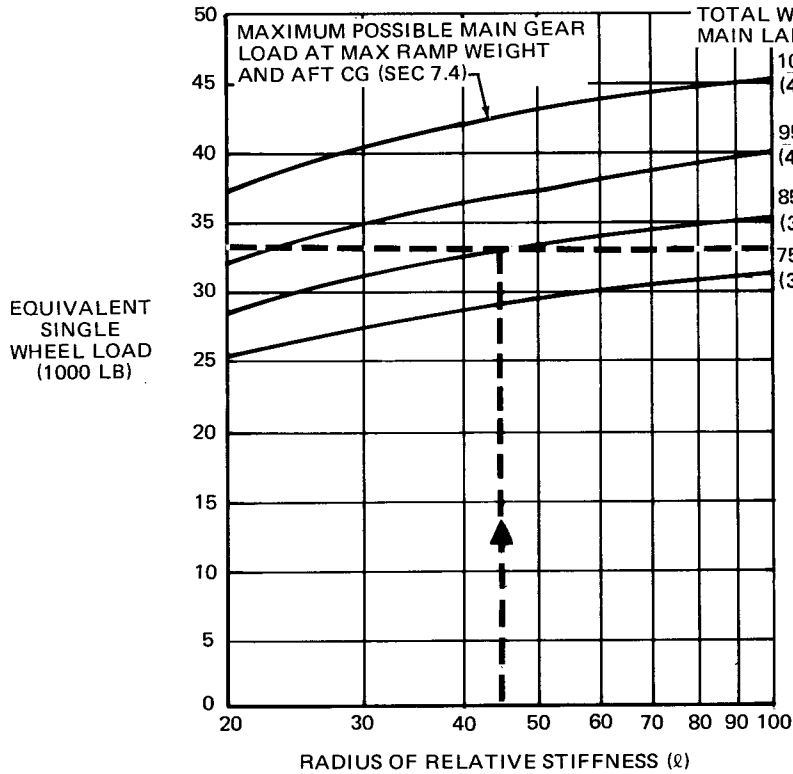

7.8 RIGID PAVEMENT REQUIREMENTS, LCN CONVERSION MODEL DC-9-41

NOTE: EQUIVALENT SINGLE WHEEL LOADS ARE DERIVED BY METHODS SHOWN IN ICAO AERODROME MANUAL.

LCN REQUIREMENTS ARE BASED ON CENTER OF SLAB LOADING

41 x 15 TIRES TIRE PRESSURE CONSTANT AT 172 PSI (12.1 KG/CM²)

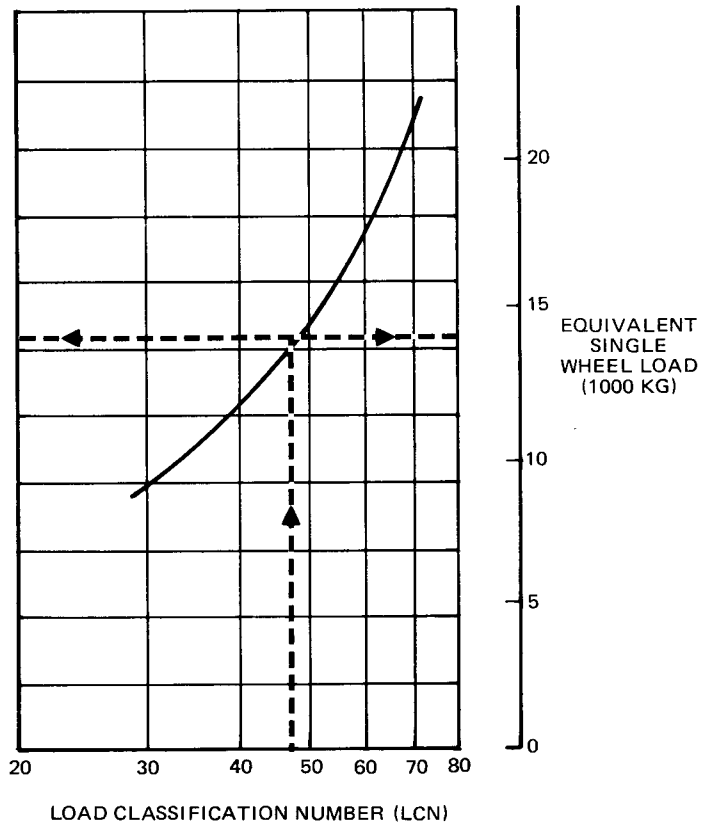
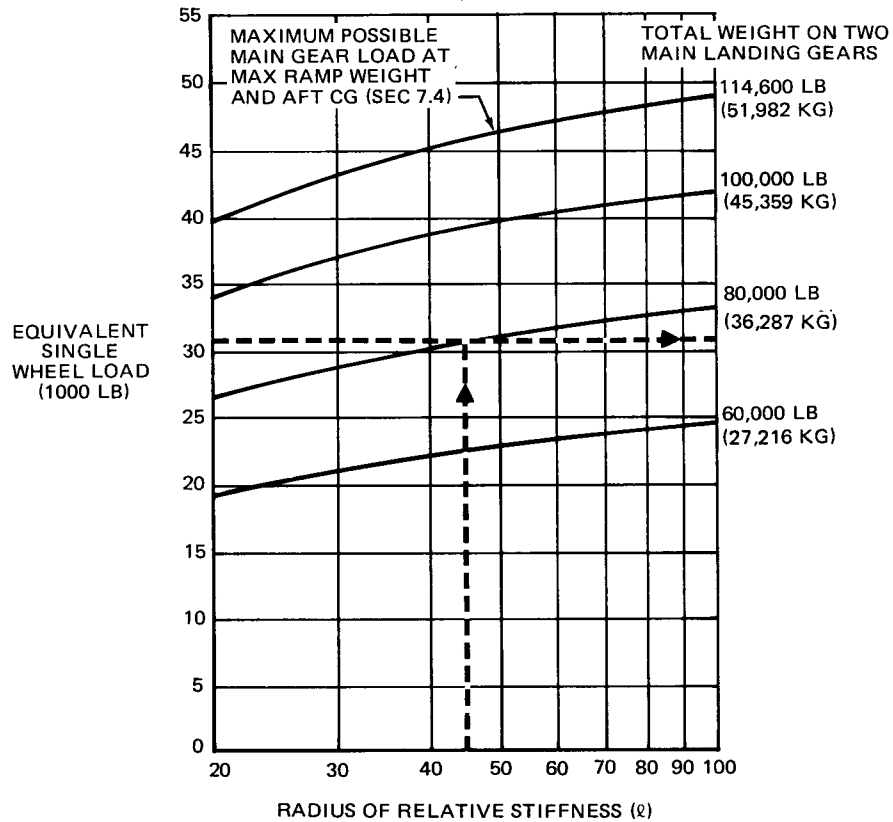

7.8 RIGID PAVEMENT REQUIREMENTS, LCN CONVERSION MODEL DC-9-51

7.8.1 Radius of Relative Stiffness (Other values of E and ℓ)

The chart of Section 7.8 presents ℓ -values based on Young's Modulus (E) of 4,000,000 psi and Poisson's Ratio (μ) of 0.15. For convenience in finding ℓ -values based on other values of E and μ the curves of Section 7.8.1 are included. For example, to find an ℓ -value based on an E of 3,000,000 psi, the "E" factor of 0.931 is multiplied by the ℓ -value found in the table of Section 7.8.1. The effect of variations of " μ " on the ℓ -value is treated in a similar manner.

RADIUS OF RELATIVE STIFFNESS (ℓ)
VALUES OF ℓ IN INCHES

FOR E = 4,000,000 P.S.I. AND μ = 0.15

$$\text{RADIUS OF RELATIVE STIFFNESS} = \ell = \sqrt[4]{\frac{E_d^3}{12(1-\mu^2)k}} = 24.1652 \sqrt[4]{\frac{d^3}{k}}$$

d in in.	k=50	k=100	k=150	k=200	k=250	k=300	k=350	k=400	k=500
6	34.84	29.30	26.47	24.63	23.30	22.26	21.42	20.72	19.59
6.5	36.99	31.11	28.11	26.16	24.74	23.64	22.74	22.00	20.80
7	39.11	32.89	29.72	27.65	26.15	24.99	24.04	23.25	21.99
7.5	41.19	34.63	31.29	29.12	27.54	26.32	25.32	24.49	23.16
8	43.23	36.35	32.85	30.57	28.91	27.62	26.58	25.70	24.31
8.5	45.24	38.04	34.37	31.99	30.25	28.91	27.81	26.90	25.44
9	47.22	39.71	35.88	33.39	31.58	30.17	29.03	28.08	26.55
9.5	49.17	41.35	37.36	34.77	32.89	31.42	30.23	29.24	27.65
10	51.10	42.97	38.83	36.14	34.17	32.65	31.42	30.39	28.74
10.5	53.01	44.57	40.28	37.48	35.45	33.87	32.59	31.52	29.81
11	54.89	46.16	41.71	38.81	36.71	35.07	33.75	32.64	30.87
11.5	56.75	47.72	43.12	40.13	37.95	36.26	34.89	33.74	31.91
12	58.59	49.27	44.52	41.43	39.18	37.44	36.02	34.84	32.95
12.5	60.41	50.80	45.90	42.72	40.40	38.60	37.14	35.92	33.97
13	62.22	52.32	47.27	43.99	41.61	39.75	38.25	36.99	34.99
13.5	64.00	53.82	48.63	45.26	42.80	40.89	39.35	38.06	35.99
14	65.77	55.31	49.98	46.51	43.98	42.02	40.44	39.11	36.99
14.5	67.53	56.78	51.31	47.75	45.16	43.15	41.51	40.15	37.97
15	69.27	58.25	52.63	48.98	46.32	44.26	42.58	41.19	38.95
15.5	70.99	59.70	53.94	50.20	47.47	45.36	43.64	42.21	39.92
16	72.70	61.13	55.24	51.41	48.62	46.45	44.70	43.23	40.88
16.5	74.40	62.56	56.53	52.61	49.75	47.54	45.74	44.24	41.84
17	76.08	63.98	57.81	53.80	50.88	48.61	46.77	45.24	42.78
17.5	77.75	65.38	59.08	54.98	52.00	49.68	47.80	46.23	43.72
18	79.41	66.78	60.34	56.16	53.11	50.74	48.82	47.22	44.66
19	82.70	69.54	62.84	58.48	55.31	52.84	50.84	49.17	46.51
20	85.95	72.27	65.30	60.77	57.47	54.91	52.84	51.10	48.33
21	89.15	74.96	67.74	63.04	59.62	56.96	54.81	53.01	50.13
22	92.31	77.63	70.14	66.28	61.73	58.98	56.75	54.89	51.91
23	95.44	80.26	72.52	67.49	63.83	60.98	58.68	56.75	53.67
24	98.54	82.86	74.87	69.68	65.90	62.96	60.58	58.59	55.41

7.8.1 RADIUS OF RELATIVE STIFFNESS
(REFERENCE: PORTLAND CEMENT ASSOCIATION)

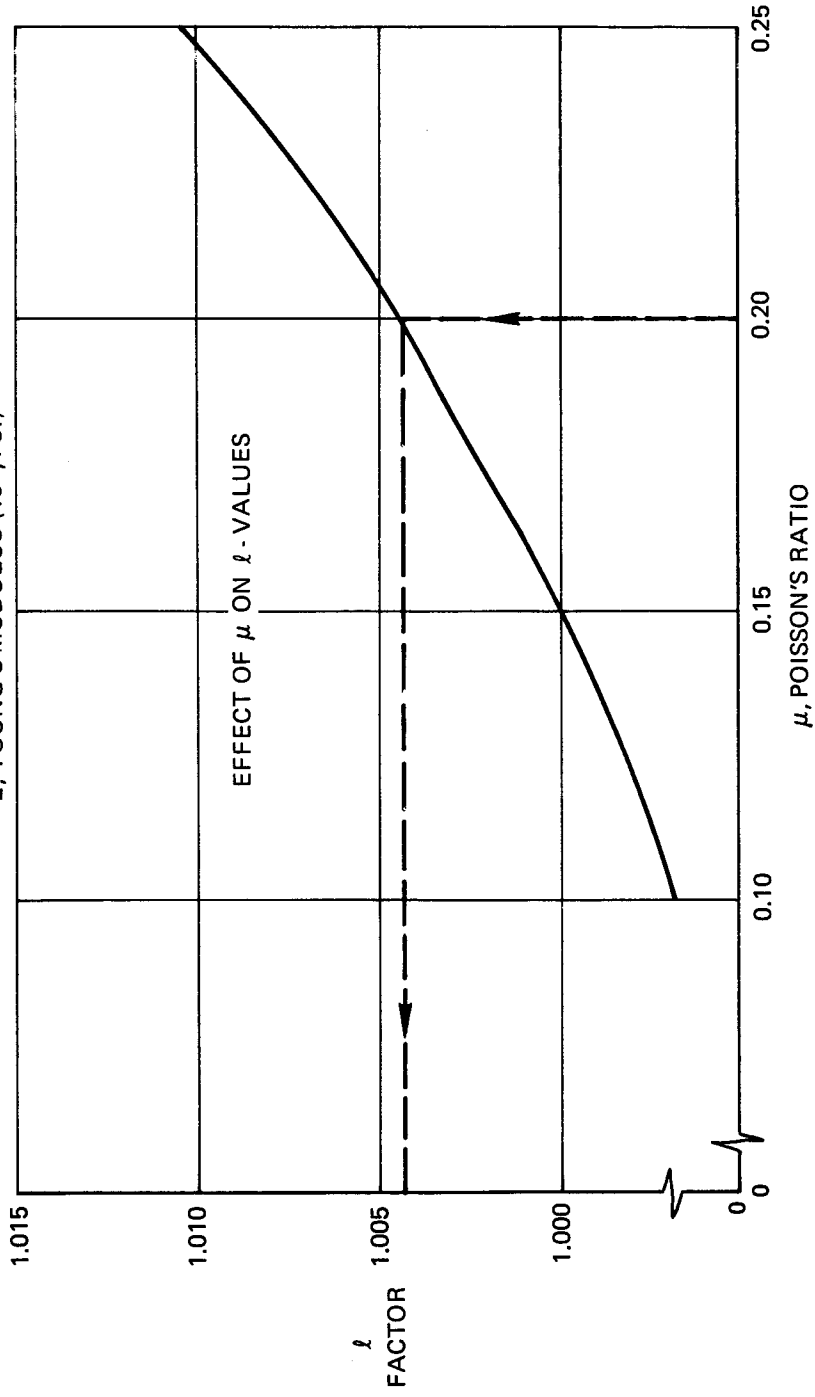
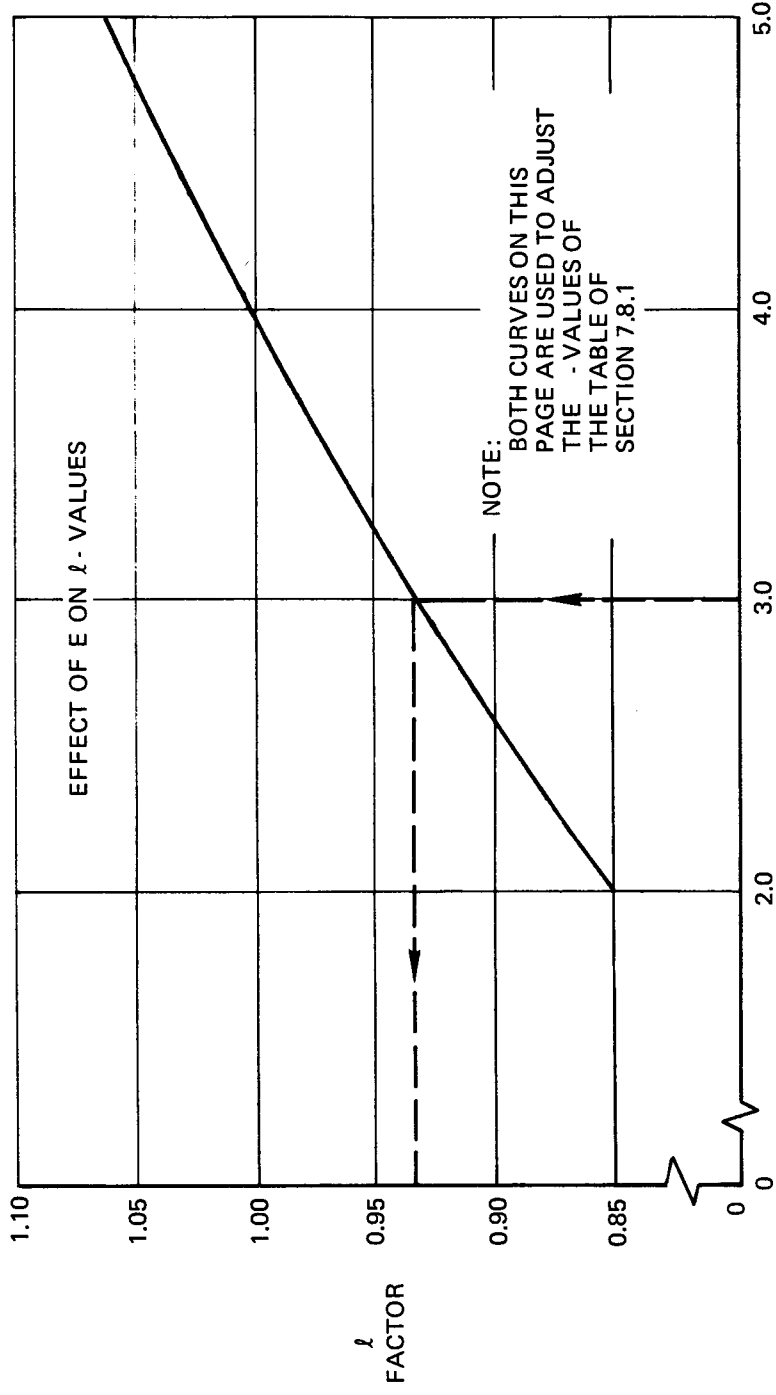

7.8.2 EFFECT OF E AND μ ON λ VALUES

7.9 ACN-PCN Reporting System: Flexible and Rigid Pavements

To determine the ACN of an aircraft on flexible or rigid pavement, both the aircraft gross weight and the subgrade strength category must be known. For an aircraft gross weight of 95,000 pounds and medium subgrade strength, the ACN for flexible pavement is 23. The ACN for rigid pavement for the same gross weight is 26.5.

Note: An aircraft with an ACN equal to or less than the reported PCN can operate on the pavement subject to any limitations on the tire pressure.

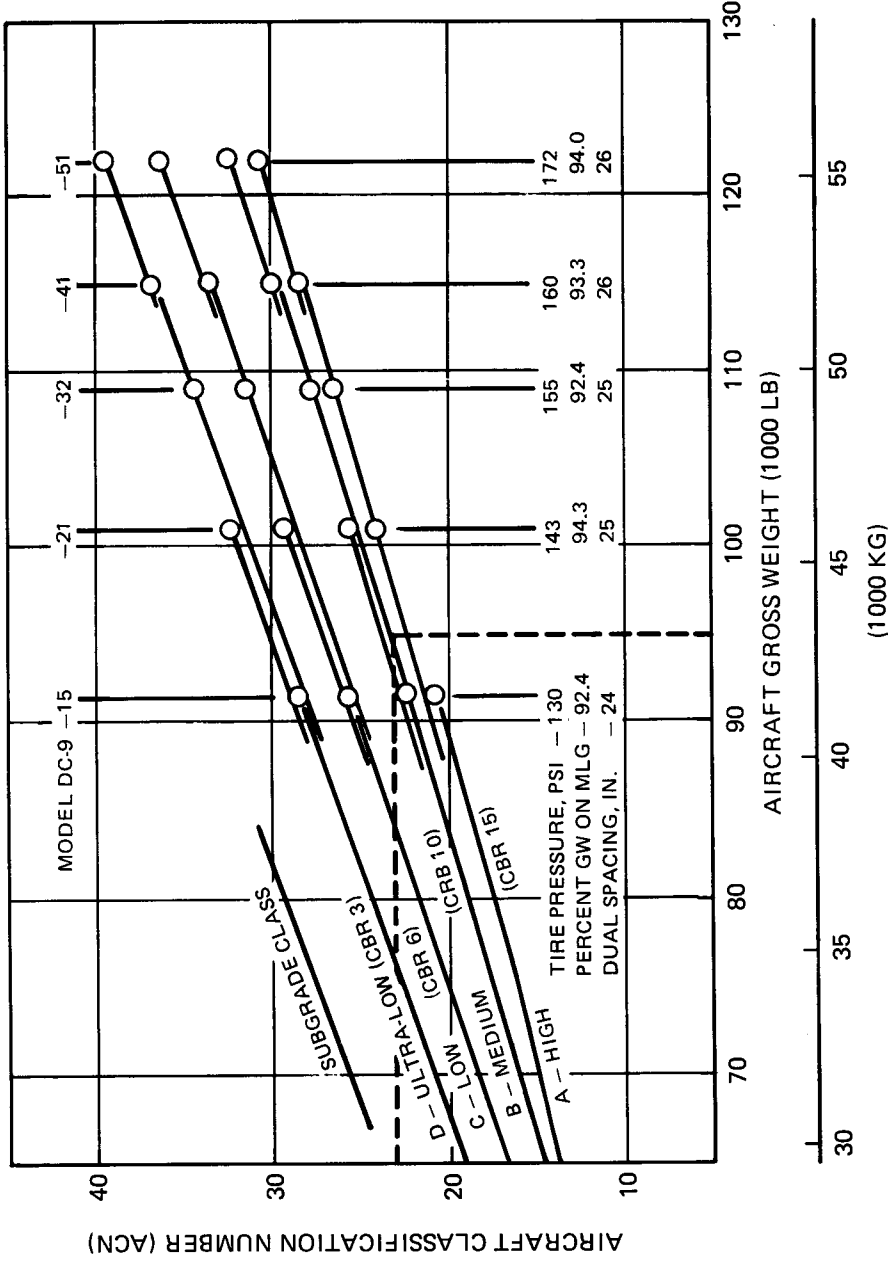

7.9 AIRCRAFT CLASSIFICATION NUMBER
7.9.1 FLEXIBLE PAVEMENT
MODELS DC-9-15, -21, -32, -41, -51

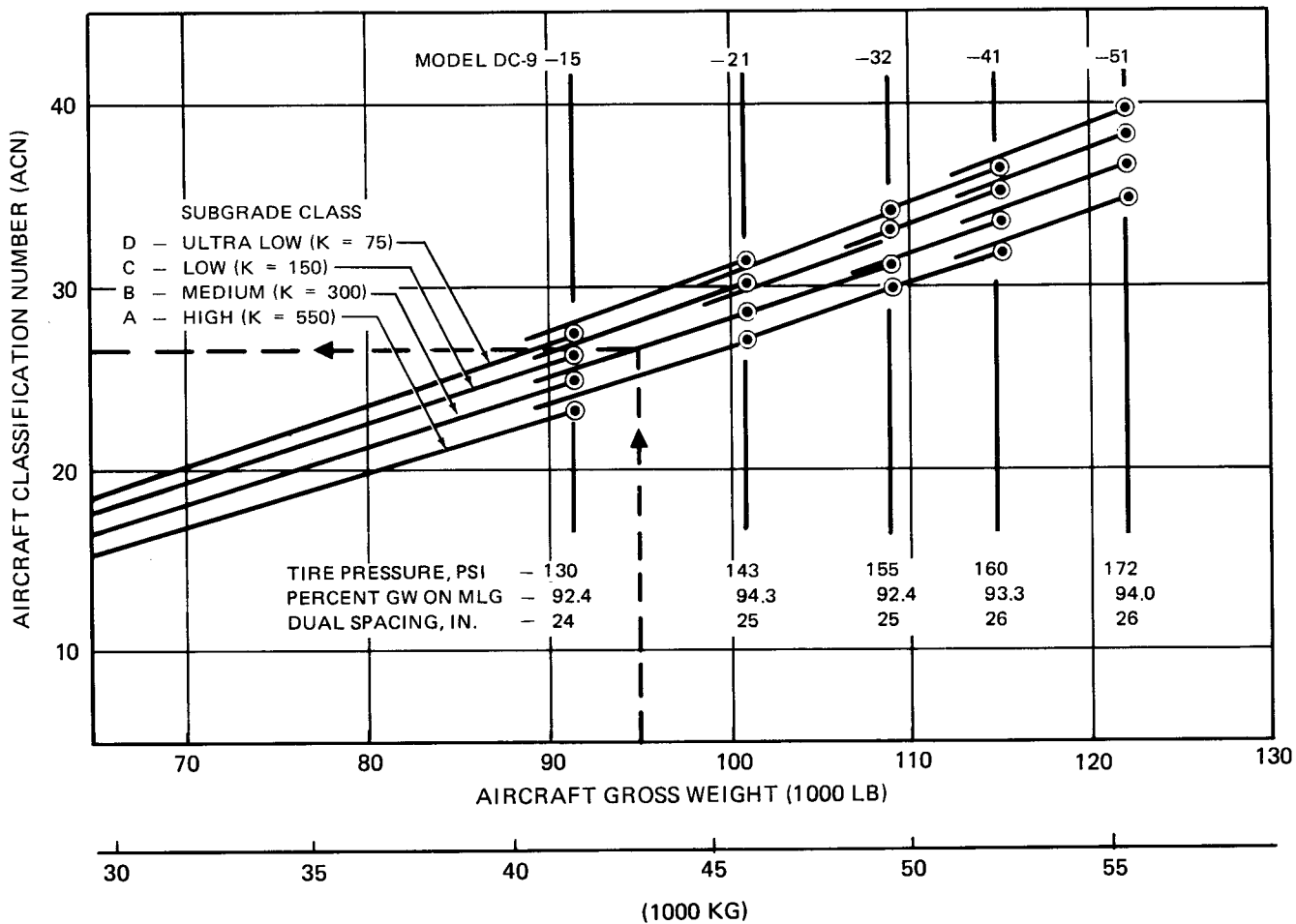

7.9 AIRCRAFT CLASSIFICATION NUMBER
 7.9.2 RIGID PAVEMENT
 MODELS DC-9-15, -21, -32, -41, -51

7.9.1 Development of ACN Charts

The ACN charts for flexible and rigid pavements were developed by methods referenced in ICAO Annex 14. The procedures to develop these charts are also described below.

The following procedure is used to develop the flexible-pavement ACN charts already shown in this subsection.

1. Determine the percentage of weight on the main gear to be used below in steps 2, 3, and 4 below. It is the maximum aft center of gravity position that yields the critical loading on the critical gear (see Section 7.4). This center of gravity position is used to determine main-gear loads at all gross weights of the model being considered.
2. Establish a flexible-pavement requirements chart using the S-77-1 design method, such as shown on the right-hand side of 7.9.3 Use standard subgrade strengths of CBR 3, 5, 10, and 15 percent and 10,000 coverages. This chart provides the same thickness values as those of Subsection 7.5, but is presented here in a different format.
3. Determine reference thickness values from the pavement requirements chart of step 2 for each standard subgrade strength and gear loading.
4. Enter the reference thickness values into the ACN flexible-pavement conversion chart shown on the left-hand side of page 7.9.3 to determine ACN. This chart was developed using the S-77-1 design method with a single tire inflated to 1.25 MPa (181 psi) pressure and 10,000 coverages. The ACN is two times the derived single-wheel load expressed in thousands of kilograms. These values of ACN were plotted as functions of aircraft gross weight, as already shown.

The following procedure is used to develop the rigid-pavement ACN charts already shown in this subsection:

1. Determine the percentage of weight on the main gear to be used in steps 2, 3, and 4 below. It is maximum aft center of gravity position that yields the critical loading on the critical gear (see Section 7.4). This center of gravity position is used to determine main-gear loads at all gross weights of the model being considered.
2. Establish a rigid-pavement-requirements chart using the PCA computer program PDILB, such as shown on the right-hand side of 7.9.4 Use standard subgrade strengths of $k = 75, 150, 300$, and 550 pci (nominal values for $k = 20, 40, 80, 150 \text{ MN/m}^3$). This chart provides the same thickness values as those of Subsection 7.7.
3. Determine reference thickness values from the pavement requirements chart of step 2 for each standard subgrade strength and gear loading at 400 psi working stress (nominal value for 2.75 MPa working stress).

4. Enter the reference thickness values into the ACN rigid-pavement conversion chart shown on the left-hand side of 7.9.4 to determine ACN. This chart was developed using the PCA computer program PDILB with a single tire inflated to 1.25 MPa (181 psi) pressure and a working stress of 400 psi. The ACN is two times the derived single-wheel load expressed in thousands of kilograms. These values of ACN were plotted as functions of aircraft gross weight, as already shown in this subsection.

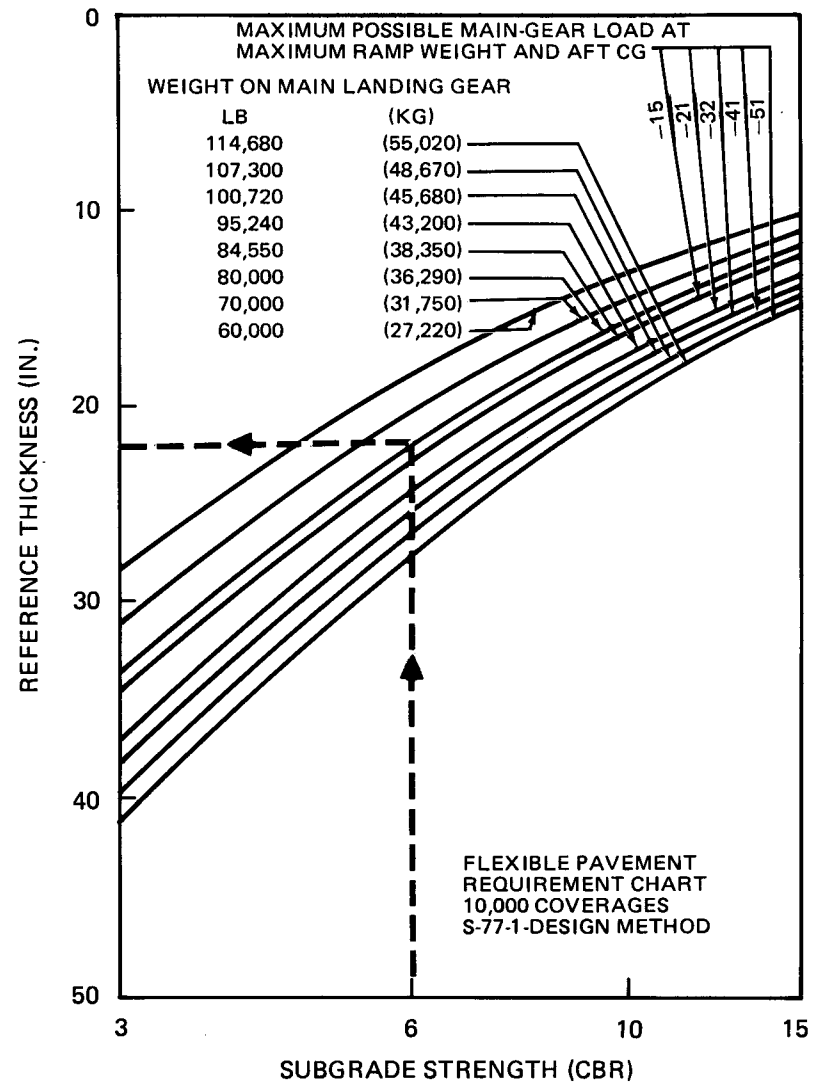
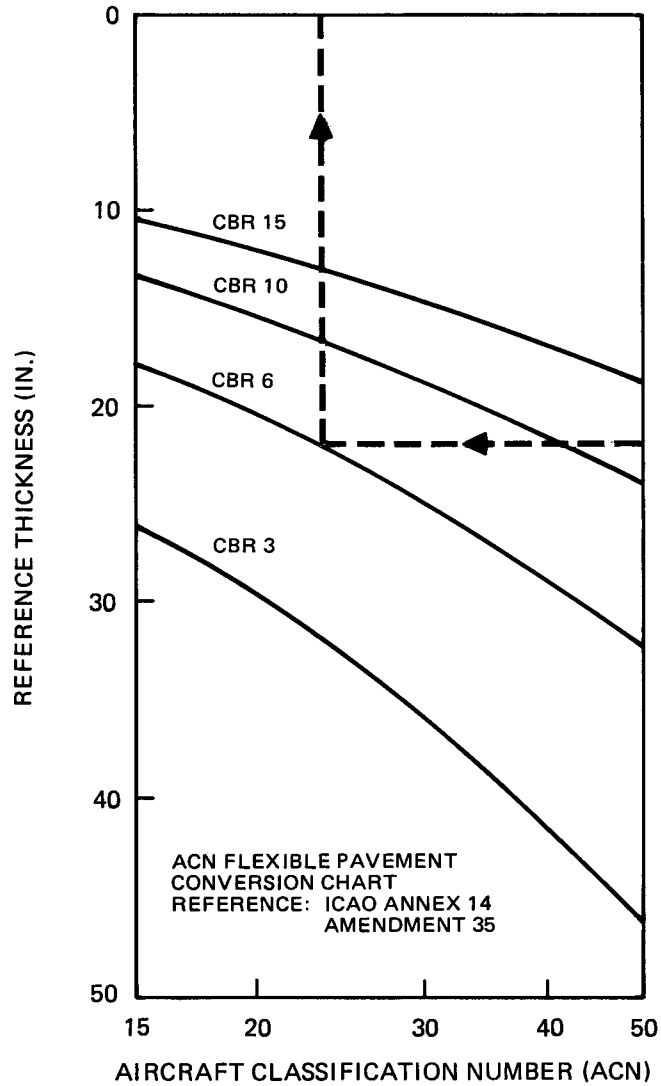

7.9 AIRCRAFT CLASSIFICATION NUMBER
7.9.3 DEVELOPMENT OF AIRCRAFT
CLASSIFICATION NUMBER (ACN) – FLEXIBLE
PAVEMENT

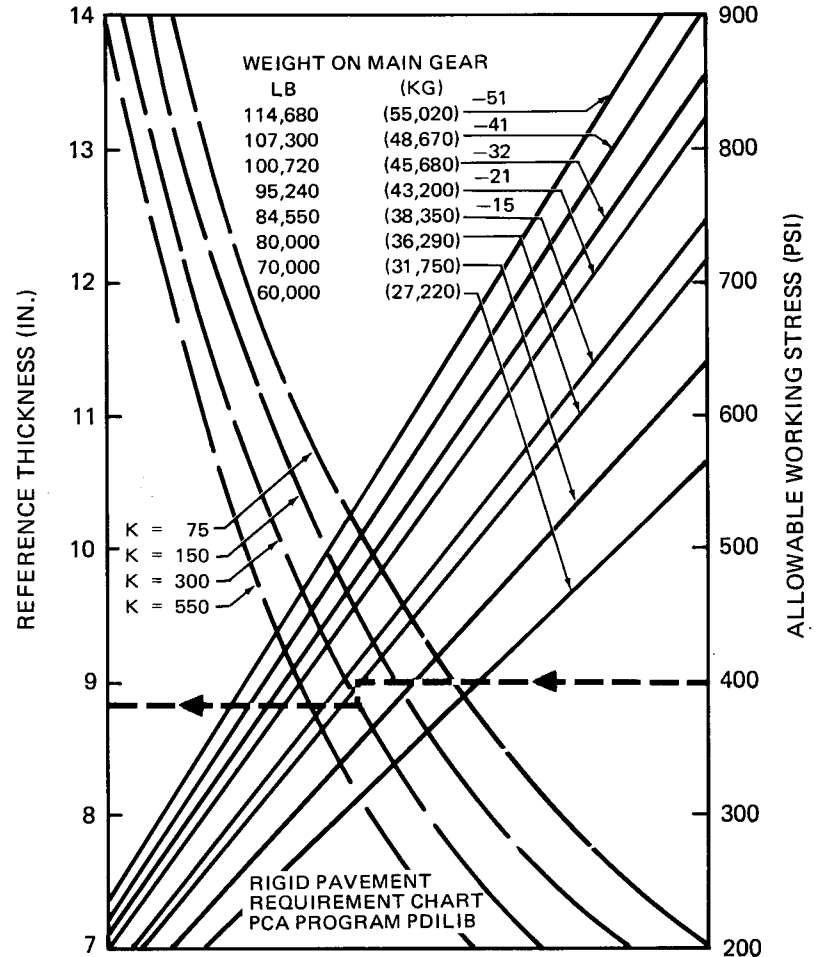
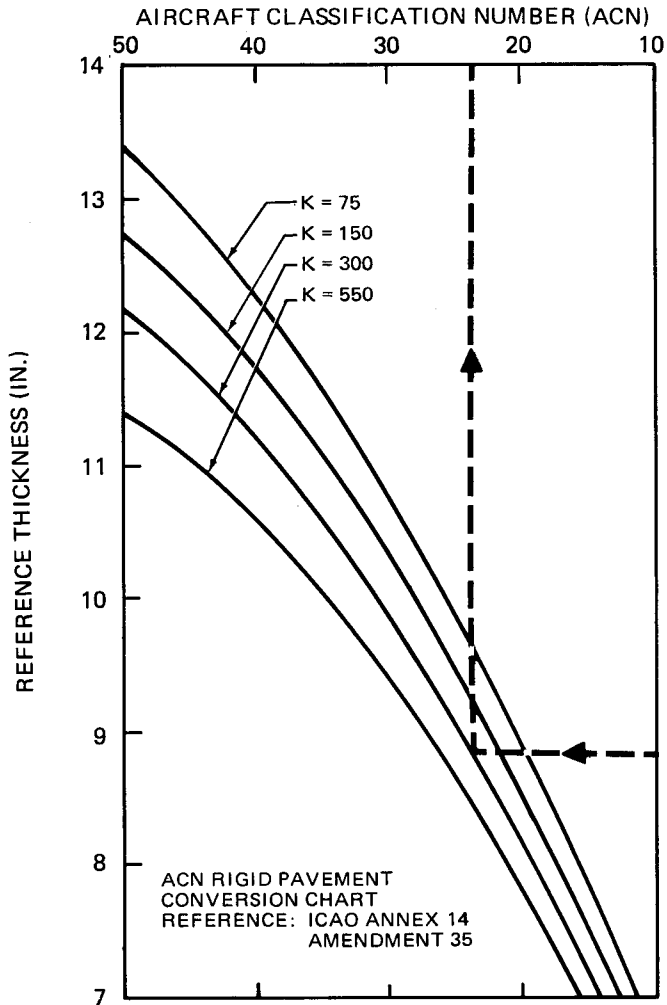

7.9 AIRCRAFT CLASSIFICATION NUMBER
7.9.4 DEVELOPMENT OF AIRCRAFT
CLASSIFICATION NUMBER (ACN) – RIGID
PAVEMENT

8.0 POSSIBLE DC-9 DERIVATIVE AIRPLANES

8.0 POSSIBLE DC-9 DERIVATIVE AIRPLANES

The derivative potential of the DC-9 is under continuing assessment. However, since late Model DC-9 series aircraft have been redesignated as the MD series aircraft, all future derivatives will have the MD designation.

9.0 SCALE DRAWINGS

SCALE: 1 IN. = 32 FT

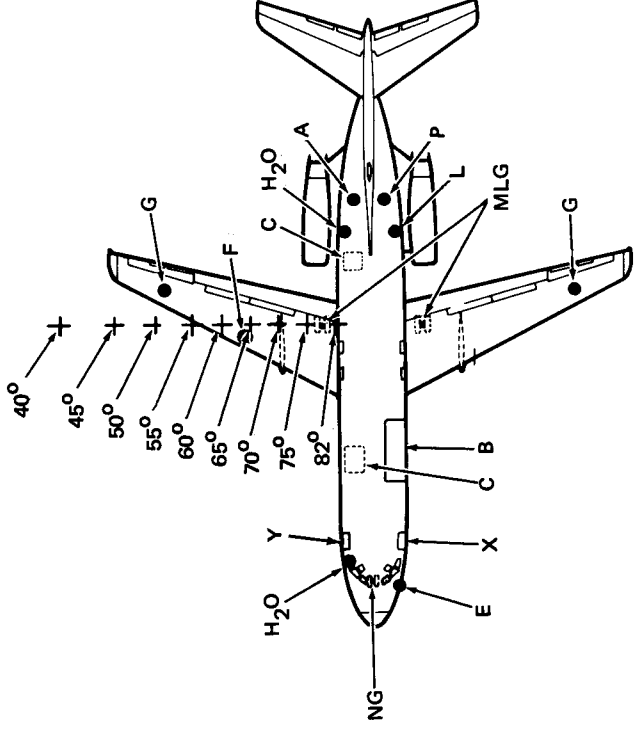

LEGEND

- | | | | |
|----|-------------------------------|-----|-------------------|
| A. | PRECONDITIONED AIR | L. | LAVATORY (1) |
| B. | MAIN CARGO DOOR | MLG | MAIN LANDING GEAR |
| C. | FWD, AFT CARGO DOORS | NG | NOSE LANDING GEAR |
| E. | ELECTRICAL - GROUND POWER | P. | PNEUMATIC POWER |
| F. | PRESSURE REFUELING POINTS (1) | X. | PASSENGER DOOR |
| G. | GRAVITY REFUELING POINTS (2) | Y. | SERVICE DOOR |
- H₂O POTABLE WATER

TURNING RADIUS POINTS, +

82°, 75°, 70°, 65°, 60°, 55°, 50°, 45°, 40°

9.0 SCALE DRAWINGS DC-9-15

SCALE: 1 IN. = 50 FT

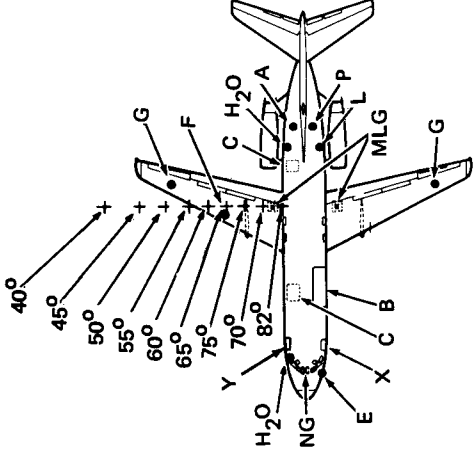

LEGEND

- | | | | |
|----|-------------------------------|-----|-------------------|
| A. | PRECONDITIONED AIR | L. | LAVATORY (1) |
| B. | MAIN CARGO DOOR | MLG | MAIN LANDING GEAR |
| C. | FWD, AFT CARGO DOORS | NG | NOSE LANDING GEAR |
| E. | ELECTRICAL – GROUND POWER | P. | PNEUMATIC POWER |
| F. | PRESSURE REFUELING POINTS (1) | X. | PASSENGER DOOR |
| G. | GRAVITY REFUELING POINTS (2) | Y. | SERVICE DOOR |
- H₂O POTABLE WATER (2)

TURNING RADIUS POINTS, +

82°, 75°, 70°, 65°, 60°, 55°, 50°, 45°, 40°

9.0 SCALE DRAWINGS

DC-9-15

SCALE: 1 IN. = 100 FT.*

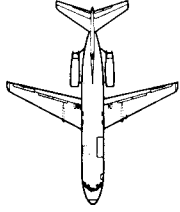

*SEE OTHER PAGES IN THIS SECTION FOR SERVICE POINT LOCATIONS.

LEGEND

- | | | | |
|----|-------------------------------|-----|-------------------|
| A. | PRECONDITIONED AIR | L. | LAVATORY (1) |
| B. | MAIN CARGO DOOR | MLG | MAIN LANDING GEAR |
| C. | FWD, AFT CARGO DOORS | NG | NOSE LANDING GEAR |
| E. | ELECTRICAL – GROUND POWER | P. | PNEUMATIC POWER |
| F. | PRESSURE REFUELING POINTS (1) | X. | PASSENGER DOOR |
| G. | GRAVITY REFUELING POINTS (2) | | |
- H₂O POTABLE WATER (2)

TURNING RADIUS POINTS, +

82°, 75°, 70°, 65°, 60°, 55°, 50°, 45°, 40°

9.0 SCALE DRAWINGS

DC-9-15

SCALE: 1 TO 500

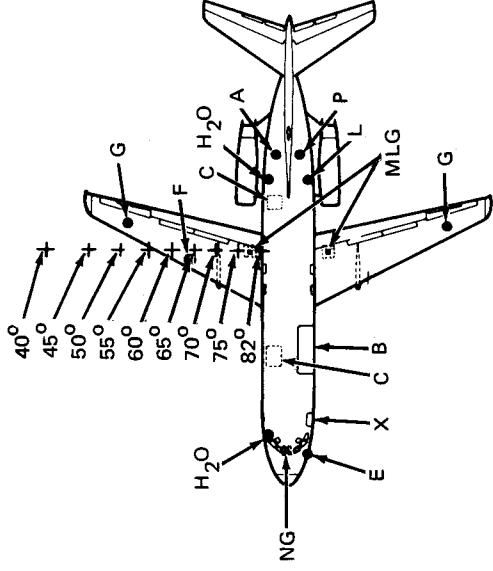

LEGEND

- | | |
|----------------------------------|-----------------------|
| A. PRECONDITIONED AIR | L. LAVATORY (1) |
| B. MAIN CARGO DOOR | MLG MAIN LANDING GEAR |
| C. FWD, AFT CARGO DOORS | NG NOSE LANDING GEAR |
| E. ELECTRICAL - GROUND POWER | P. PNEUMATIC POWER |
| F. PRESSURE REFUELING POINTS (1) | X. PASSENGER DOOR |
| G. GRAVITY REFUELING POINTS (2) | |

H₂O POTABLE WATER (2)

TURNING RADIUS POINTS, +

82°, 75°, 70°, 65°, 60°, 55°, 50°, 45°, 40°

**9.0 SCALE DRAWINGS
DC-9-15**

SCALE: 1 TO 1000

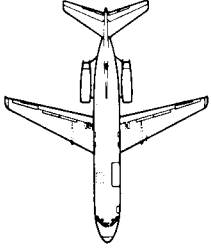

*SEE OTHER PAGES IN THIS SECTION FOR SERVICE POINT LOCATIONS.

LEGEND

- | | | | |
|----|-------------------------------|-----|-------------------|
| A. | PRECONDITIONED AIR | L. | LAVATORY (1) |
| B. | MAIN CARGO DOOR | MLG | MAIN LANDING GEAR |
| C. | FWD, AFT CARGO DOORS | NG | NOSE LANDING GEAR |
| E. | ELECTRICAL -- GROUND POWER | P. | PNEUMATIC POWER |
| F. | PRESSURE REFUELING POINTS (1) | X. | PASSENGER DOOR |
| G. | GRAVITY REFUELING POINTS (2) | | |
- H₂O POTABLE WATER (2)

TURNING RADIUS POINTS, +
82°, 75°, 70°, 65°, 60°, 55°, 50°, 45°, 40°

9.0 SCALE DRAWINGS

DC-9-15

SCALE: 1 IN. = 32 FT

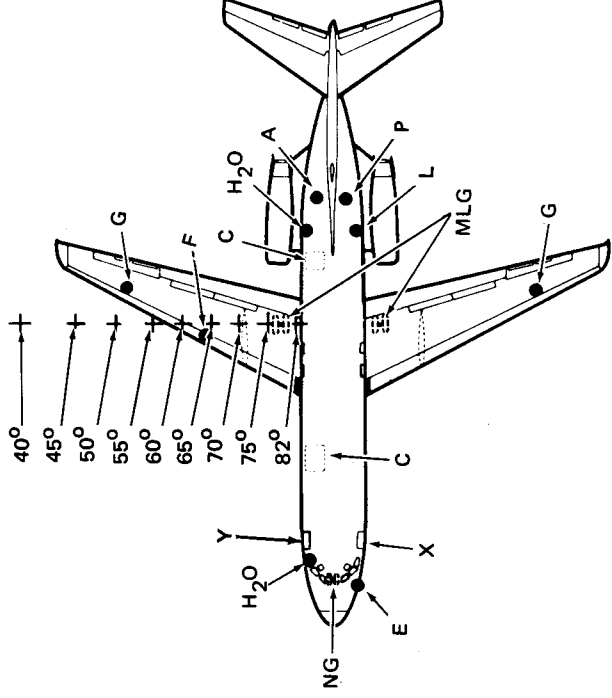

LEGEND

- | | |
|----------------------------------|-----------------------|
| A. PRECONDITIONED AIR | L. LAVATORY (1) |
| B. MAIN CARGO DOOR | MLG MAIN LANDING GEAR |
| C. FWD, AFT CARGO DOORS | NG NOSE LANDING GEAR |
| E. ELECTRICAL - GROUND POWER | P. PNEUMATIC POWER |
| F. PRESSURE REFUELING POINTS (1) | X. PASSENGER DOOR |
| G. GRAVITY REFUELING POINTS (2) | Y. SERVICE DOOR |

H₂O POTABLE WATER (2)

TURNING RADIUS POINTS,+
82°, 75°, 70°, 65°, 60°, 55°, 50°, 45°, 40°

9.0 SCALE DRAWINGS
DC-9-21

SCALE: 1 IN. = 50 FT

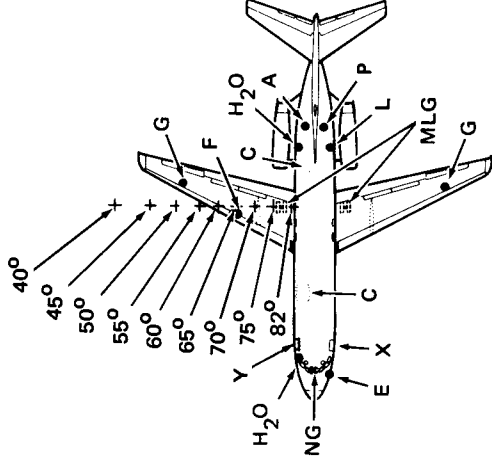

LEGEND

- | | | | |
|----|-------------------------------|-----|-------------------|
| A. | PRECONDITIONED AIR | L. | LAVATORY (1) |
| B. | MAIN CARGO DOOR | MLG | MAIN LANDING GEAR |
| C. | FWD, AFT CARGO DOORS | NG | NOSE LANDING GEAR |
| E. | ELECTRICAL – GROUND POWER | P. | PNEUMATIC POWER |
| F. | PRESSURE REFUELING POINTS (1) | X. | PASSENGER DOOR |
| G. | GRAVITY REFUELING POINTS (2) | Y. | SERVICE DOOR |

H₂O POTABLE WATER (2)

TURNING RADIUS POINTS, +
82°, 75°, 70°, 65°, 60°, 55°, 50°, 45°, 40°

9.0 SCALE DRAWINGS
DC-9-21

SCALE: 1 IN. = 100 FT.*

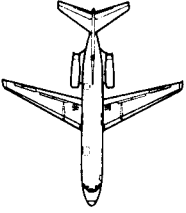

*SEE OTHER PAGES IN THIS SECTION FOR SERVICE POINT LOCATIONS.

LEGEND

- | | |
|------------------------------------|-----------------------|
| A. PRECONDITIONED AIR | L. LAVATORY (1) |
| B. MAIN CARGO DOOR | MLG MAIN LANDING GEAR |
| C. FWD, AFT CARGO DOORS | NG NOSE LANDING GEAR |
| E. ELECTRICAL – GROUND POWER | P. PNEUMATIC POWER |
| F. PRESSURE REFUELING POINTS (1) | X. PASSENGER DOOR |
| G. GRAVITY REFUELING POINTS (2) | |
| H ₂ O POTABLE WATER (2) | |

TURNING RADIUS POINTS, +
82°, 75°, 70°, 65°, 60°, 55°, 50°, 45°, 40°

9.0 SCALE DRAWINGS

DC-9-21

SCALE: 1 TO 500

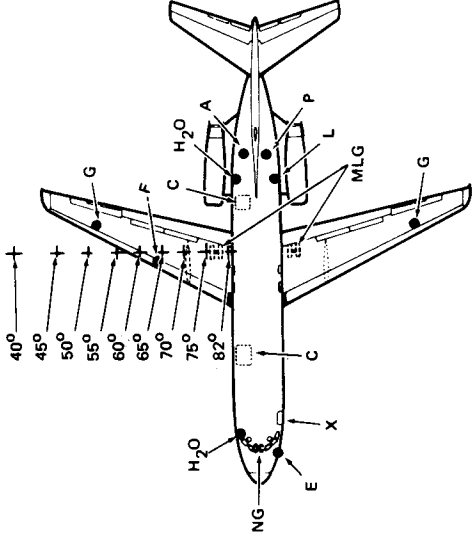

LEGEND

- A. PRECONDITIONED AIR
- B. MAIN CARGO DOOR
- C. FWD, AFT CARGO DOORS
- E. ELECTRICAL – GROUND POWER
- F. PRESSURE REFUELING POINTS (1)
- G. GRAVITY REFUELING POINTS (2)
H₂O POTABLE WATER (2)
- L. LAVATORY (1)
- MLG MAIN LANDING GEAR
- NG NOSE LANDING GEAR
- P. PNEUMATIC POWER
- X. PASSENGER DOOR

TURNING RADIUS POINTS, +
82°, 75°, 70°, 65°, 60°, 55°, 50°, 45°, 40°

9.0 SCALE DRAWINGS
DC-9-21

SCALE: 1 TO 1000

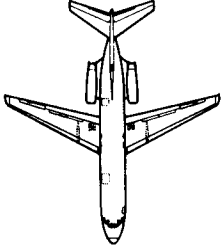

*SEE OTHER PAGES IN THIS SECTION FOR SERVICE POINT LOCATIONS.

LEGEND

- | | | | |
|----|-------------------------------|-----|-------------------|
| A. | PRECONDITIONED AIR | L. | LAVATORY (1) |
| B. | MAIN CARGO DOOR | MLG | MAIN LANDING GEAR |
| C. | FWD, AFT CARGO DOORS | NG | NOSE LANDING GEAR |
| E. | ELECTRICAL – GROUND POWER | P. | PNEUMATIC POWER |
| F. | PRESSURE REFUELING POINTS (1) | X. | PASSENGER DOOR |
| G. | GRAVITY REFUELING POINTS (2) | | |
- H₂O POTABLE WATER (2)

TURNING RADIUS POINTS, +
82°, 75°, 70°, 65°, 60°, 55°, 50°, 45°, 40°

9.0 SCALE DRAWINGS

DC-9-21

SCALE: 1 IN. = 32 FT

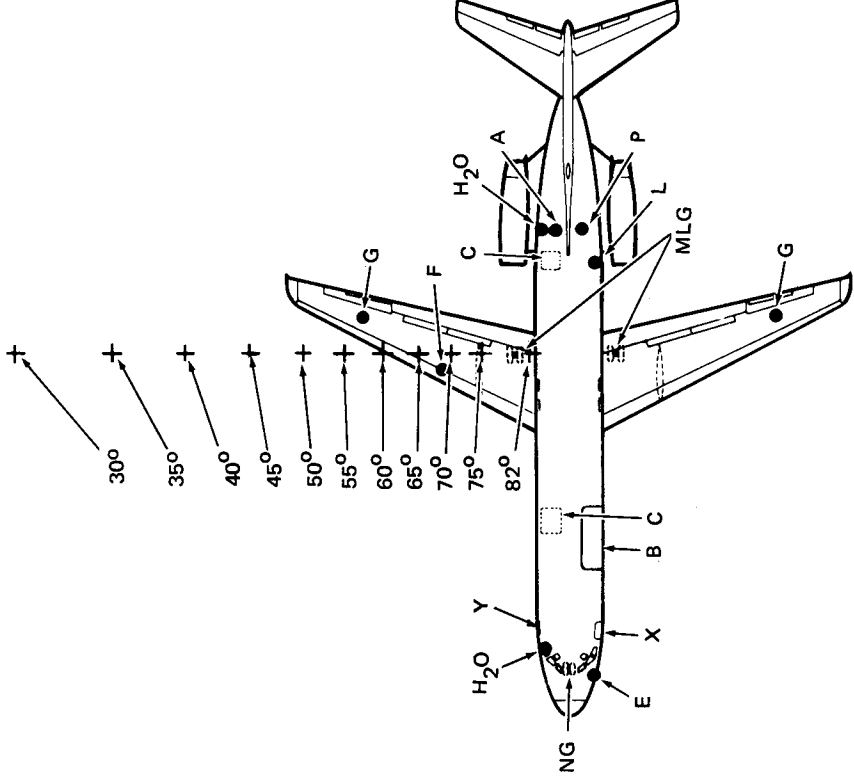

LEGEND

- | | |
|----------------------------------|-----------------------|
| A. PRECONDITIONED AIR | L. LAVATORY (1) |
| B. MAIN CARGO DOOR | MLG MAIN LANDING GEAR |
| C. FWD, AFT CARGO DOORS | NG NOSE LANDING GEAR |
| E. ELECTRICAL – GROUND POWER | P. PNEUMATIC POWER |
| F. PRESSURE REFUELING POINTS (1) | X. PASSENGER DOOR |
| G. GRAVITY REFUELING POINTS (2) | Y. SERVICE DOOR |
- H₂O POTABLE WATER (2)

TURNING RADIUS POINTS, +
 82°, 75°, 70°, 65°, 60°, 55°, 50°, 45°, 40°, 35°, 30°

9.0 SCALE DRAWINGS
 DC-9-32

SCALE: 1 IN. = 50 FT

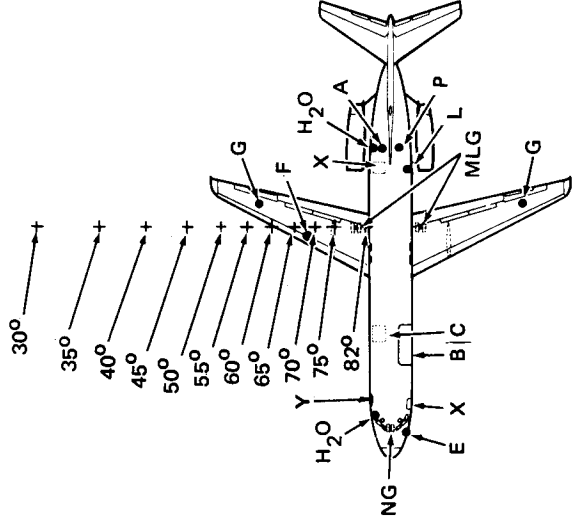

LEGEND

- | | | | |
|----|-------------------------------|------------------|-------------------|
| A. | PRECONDITIONED AIR | H ₂ O | POTABLE WATER (2) |
| B. | MAIN CARGO DOOR | L. | LAVATORY (1) |
| C. | FWD, AFT CARGO DOORS | MLG | MAIN LANDING GEAR |
| E. | ELECTRICAL – GROUND POWER | NG | NOSE LANDING GEAR |
| F. | PRESSURE REFUELING POINTS (1) | P. | PNEUMATIC POWER |
| G. | GRAVITY REFUELING POINTS (2) | X. | PASSENGER DOOR |
| | | Y. | SERVICE DOOR |

TURNING RADIUS POINTS, +

82°, 75°, 70°, 65°, 60°, 55°, 50°, 45°, 40°, 35°, 30°

9.0 SCALE DRAWINGS
DC-9-32

SCALE: 1 IN. = 100 FT.*

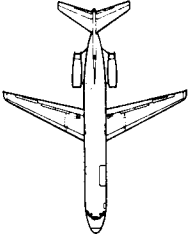

*SEE OTHER PAGES IN THIS SECTION FOR SERVICE POINT LOCATIONS.

LEGEND

- | | |
|------------------------------------|-----------------------|
| A. PRECONDITIONED AIR | L. LAVATORY (1) |
| B. MAIN CARGO DOOR | MLG MAIN LANDING GEAR |
| C. FWD, AFT CARGO DOORS | NG NOSE LANDING GEAR |
| E. ELECTRICAL – GROUND POWER | P. PNEUMATIC POWER |
| F. PRESSURE REFUELING POINTS (1) | X. PASSENGER DOOR |
| G. GRAVITY REFUELING POINTS (2) | |
| H ₂ O POTABLE WATER (2) | |

TURNING RADIUS POINTS, +
82°, 75°, 70°, 65°, 60°, 55°, 50°, 45°, 40°, 35°, 30°

**9.0 SCALE DRAWINGS
DC-9-32**

SCALE: 1 TO 500

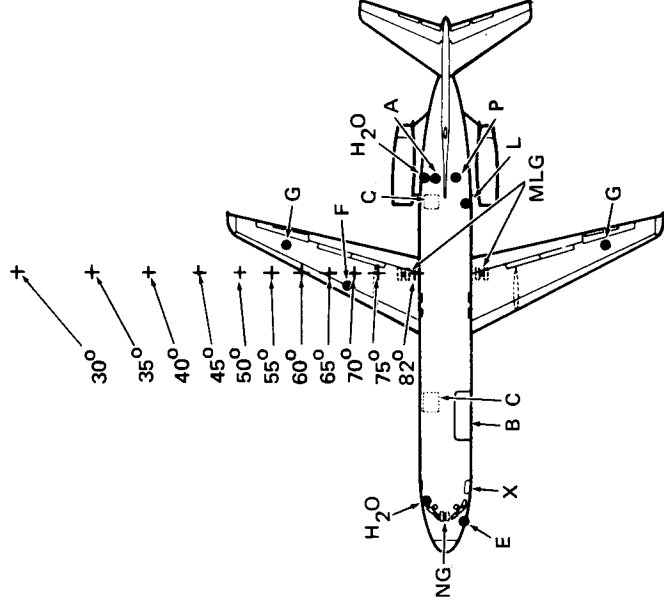

LEGEND

- | | | | |
|----|-------------------------------|------------------|-------------------|
| A. | PRECONDITIONED AIR | H ₂ O | POTABLE WATER (2) |
| B. | MAIN CARGO DOOR | L. | LAVATORY (1) |
| C. | FWD, AFT CARGO DOORS | MLG | MAIN LANDING GEAR |
| E. | ELECTRICAL – GROUND POWER | NG | NOSE LANDING GEAR |
| F. | PRESSURE REFUELING POINTS (1) | P. | PNEUMATIC POWER |
| G. | GRAVITY REFUELING POINTS (2) | X. | PASSENGER DOOR |

TURNING RADIUS POINTS, +

82°, 75°, 70°, 65°, 60°, 55°, 50°, 45°, 40°, 35°, 30°

9.0 SCALE DRAWINGS

DC-9-32

196

REV 5/84

SCALE: 1 TO 1000

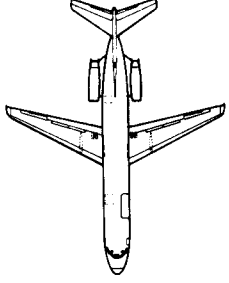

*SEE OTHER PAGES IN THIS SECTION FOR SERVICE POINT LOCATIONS.

LEGEND

- | | | | |
|----|-------------------------------|-----|-------------------|
| A. | PRECONDITIONED AIR | L. | LAVATORY (1) |
| B. | MAIN CARGO DOOR | MLG | MAIN LANDING GEAR |
| C. | FWD, AFT CARGO DOORS | NG | NOSE LANDING GEAR |
| E. | ELECTRICAL – GROUND POWER | P. | PNEUMATIC POWER |
| F. | PRESSURE REFUELING POINTS (1) | X. | PASSENGER DOOR |
| G. | GRAVITY REFUELING POINTS (2) | | |
- H₂O POTABLE WATER (2)

TURNING RADIUS POINTS, +

82°, 75°, 70°, 65°, 60°, 55°, 50°, 45°, 40°, 35°, 30°

9.0 SCALE DRAWINGS

DC-9-32

SCALE: 1 IN. = 32 FT

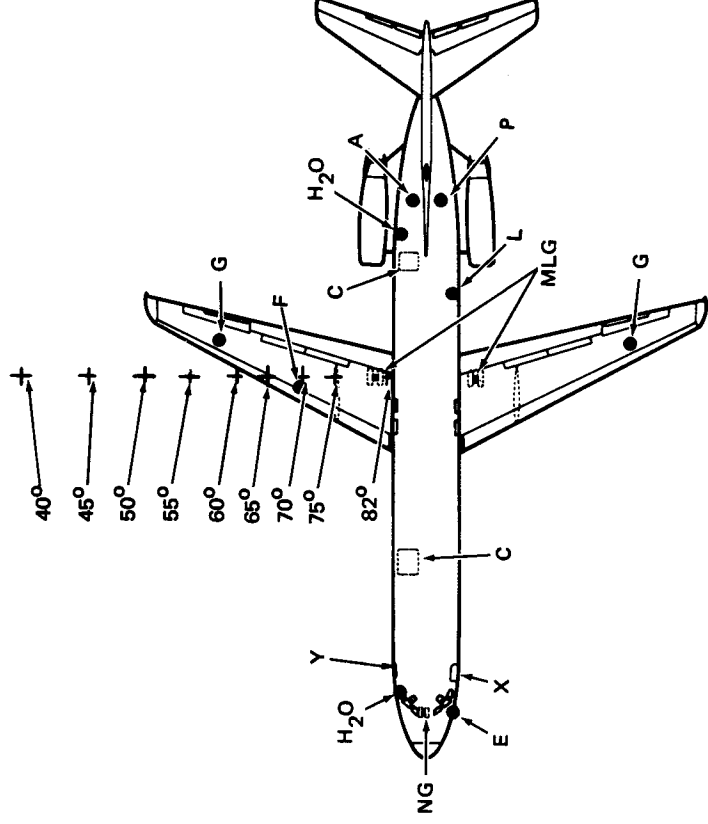

LEGEND

- | | | | |
|----|-------------------------------|-----|-------------------|
| A. | PRECONDITIONED AIR | L. | LAVATORY (1) |
| B. | MAIN CARGO DOOR (NONE) | MLG | MAIN LANDING GEAR |
| C. | FWD, AFT CARGO DOORS | NG | NOSE LANDING GEAR |
| E. | ELECTRICAL - GROUND POWER | P. | PNEUMATIC POWER |
| F. | PRESSURE REFUELING POINTS (1) | X. | PASSENGER DOOR |
| G. | GRAVITY REFUELING POINTS (2) | Y. | SERVICE DOOR |
- H₂O POTABLE WATER (2)

TURNING RADIUS POINTS, +
82°, 75°, 70°, 65°, 60°, 55°, 50°, 45°, 40°

9.0 SCALE DRAWINGS
DC-9-41

SCALE: 1 IN. = 50 FT

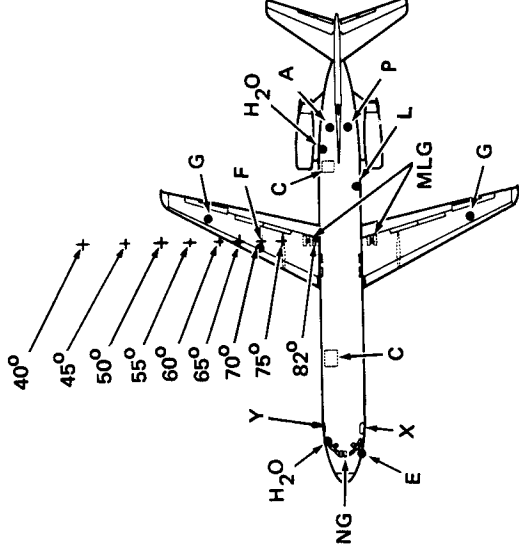

LEGEND

- | | | | |
|----|-------------------------------|-----|-------------------|
| A. | PRECONDITIONED AIR | L. | LAVATORY (1) |
| B. | MAIN CARGO DOOR (NONE) | MLG | MAIN LANDING GEAR |
| C. | FWD, AFT CARGO DOORS | NG | NOSE LANDING GEAR |
| E. | ELECTRICAL - GROUND POWER | P. | PNEUMATIC POWER |
| F. | PRESSURE REFUELING POINTS (1) | X. | PASSENGER DOOR |
| G. | GRAVITY REFUELING POINTS (2) | Y. | SERVICE DOOR |
- H₂O POTABLE WATER (2)

TURNING RADIUS POINTS, +
82°, 75°, 70°, 65°, 60°, 55°, 50°, 45°, 40°

9.0 SCALE DRAWINGS DC-9-41

SCALE: 1 IN. = 100 FT.*

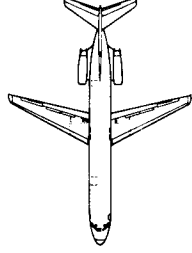

*SEE OTHER PAGES IN THIS SECTION FOR SERVICE POINT LOCATIONS.

LEGEND

- | | |
|---|-----------------------|
| A. PRECONDITIONED AIR | L. LAVATORY (1) |
| B. MAIN CARGO DOOR (NONE) | MLG MAIN LANDING GEAR |
| C. FWD, AFT CARGO DOORS | NG NOSE LANDING GEAR |
| E. ELECTRICAL – GROUND POWER | P. PNEUMATIC POWER |
| F. PRESSURE REFUELING POINTS (1) | X. PASSENGER DOOR |
| G. GRAVITY REFUELING POINTS (2)
H ₂ O POTABLE WATER (2) | |

TURNING RADIUS POINTS, +

82°, 75°, 70°, 65°, 60°, 55°, 50°, 45°, 40°

9.0 SCALE DRAWINGS DC-9-41

200

REV F5/84

SCALE: 1 TO 500

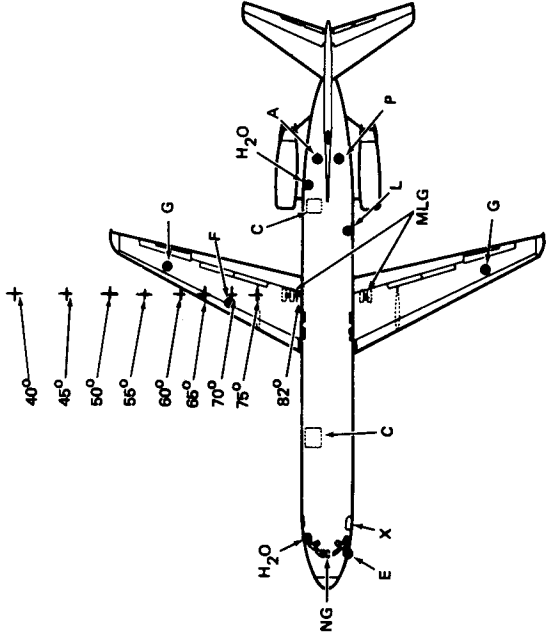

LEGEND

- A. PRECONDITIONED AIR
- B. MAIN CARGO DOOR (NONE)
- C. FWD, AFT CARGO DOORS
- E. ELECTRICAL - GROUND POWER
- F. PRESSURE REFUELING POINTS (1)
- G. GRAVITY REFUELING POINTS (2)
- H₂O POTABLE WATER (2)
- L. LAVATORY (1)
- MLG MAIN LANDING GEAR
- NG NOSE LANDING GEAR
- P. PNEUMATIC POWER
- X. PASSENGER DOOR

TURNING RADIUS POINTS, +
82°, 75°, 70°, 65°, 60°, 55°, 50°, 45°, 40°

9.0 SCALE DRAWINGS
DC-9-41

SCALE: 1 TO 1000

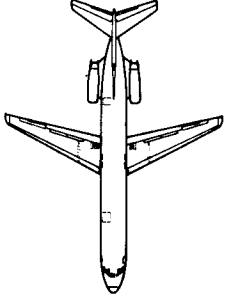

*SEE OTHER PAGES IN THIS SECTION FOR SERVICE POINT LOCATIONS.

LEGEND

A. PRECONDITIONED AIR	L. LAVATORY (1)
B. MAIN CARGO DOOR (NONE)	MLG MAIN LANDING GEAR
C. FWD, AFT CARGO DOORS	NG NOSE LANDING GEAR
E. ELECTRICAL – GROUND POWER	P. PNEUMATIC POWER
F. PRESSURE REFUELING POINTS (1)	X. PASSENGER DOOR
G. GRAVITY REFUELING POINTS (2) H ₂ O POTABLE WATER (2)	

TURNING RADIUS POINTS, +

82°, 75°, 70°, 65°, 60°, 55°, 50°, 45°, 40°

9.0 SCALE DRAWINGS

DC-9-41

SCALE: 1 IN. = 32 FT

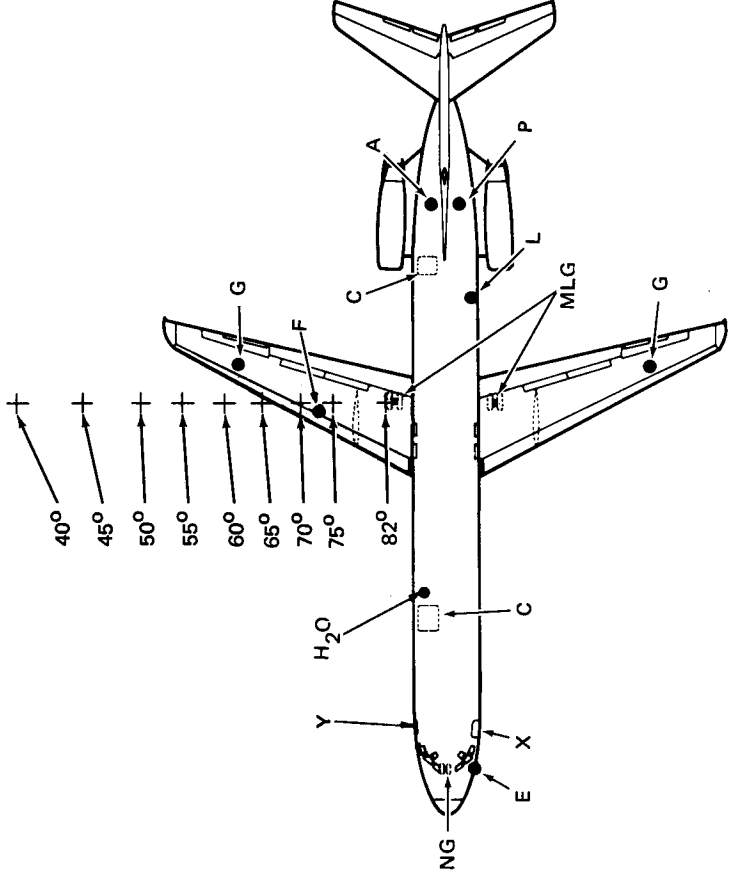

LEGEND

- A. PRECONDITIONED AIR
- B. MAIN CARGO DOOR (NONE)
- C. FWD, AFT CARGO DOORS
- E. ELECTRICAL - GROUND POWER
- F. PRESSURE REFUELING POINTS (1)
- G. GRAVITY REFUELING POINTS (2)
H₂O POTABLE WATER
- L. LAVATORY (1)
- MLG MAIN LANDING GEAR
- NG NOSE LANDING GEAR
- P. PNEUMATIC POWER
- X. PASSENGER DOOR
- Y. SERVICE DOOR

TURNING RADIUS POINTS, +
82°, 75°, 70°, 65°, 60°, 55°, 50°, 45°, 40°

9.0 SCALE DRAWINGS
DC-9-51

SCALE: 1 IN. = 50 FT

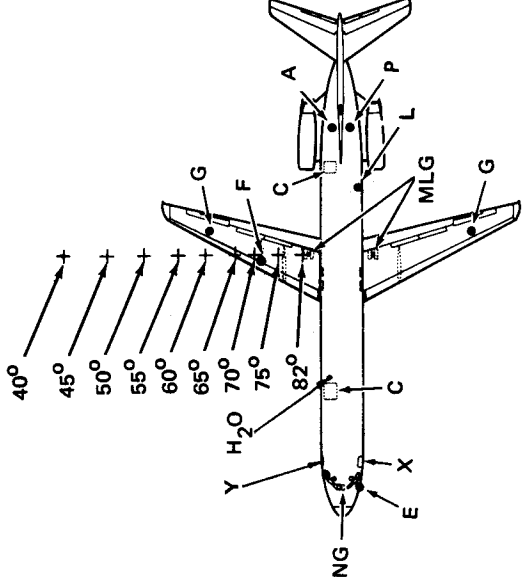

LEGEND

- | | |
|----------------------------------|-----------------------|
| A. PRECONDITIONED AIR | L. LAVATORY (1) |
| B. MAIN CARGO DOOR (NONE) | MLG MAIN LANDING GEAR |
| C. FWD, AFT CARGO DOORS | NG NOSE LANDING GEAR |
| E. ELECTRICAL - GROUND POWER | P. PNEUMATIC POWER |
| F. PRESSURE REFUELING POINTS (1) | X. PASSENGER DOOR |
| G. GRAVITY REFUELING POINTS (2) | Y. SERVICE DOOR |
- H₂O POTABLE WATER

TURNING RADIUS POINTS, +

82°, 75°, 70°, 65°, 60°, 55°, 50°, 45°, 40°

9.0 SCALE DRAWINGS

DC-9-51

SCALE: 1 IN. = 100 FT.

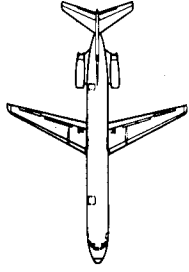

*SEE OTHER PAGES IN THIS SECTION FOR SERVICE POINT LOCATIONS.

LEGEND

- | | |
|------------------------------------|-----------------------|
| A. PRECONDITIONED AIR | L. LAVATORY (1) |
| B. MAIN CARGO DOOR (NONE) | MLG MAIN LANDING GEAR |
| C. FWD, AFT CARGO DOORS | NG NOSE LANDING GEAR |
| E. ELECTRICAL – GROUND POWER | P. PNEUMATIC POWER |
| F. PRESSURE REFUELING POINTS (1) | X. PASSENGER DOOR |
| G. GRAVITY REFUELING POINTS (2) | |
| H ₂ O POTABLE WATER (2) | |

TURNING RADIUS POINTS, +
82°, 75°, 70°, 65°, 60°, 55°, 50°, 45°, 40°

9.0 SCALE DRAWINGS

DC-9-51

SCALE: 1 TO 500

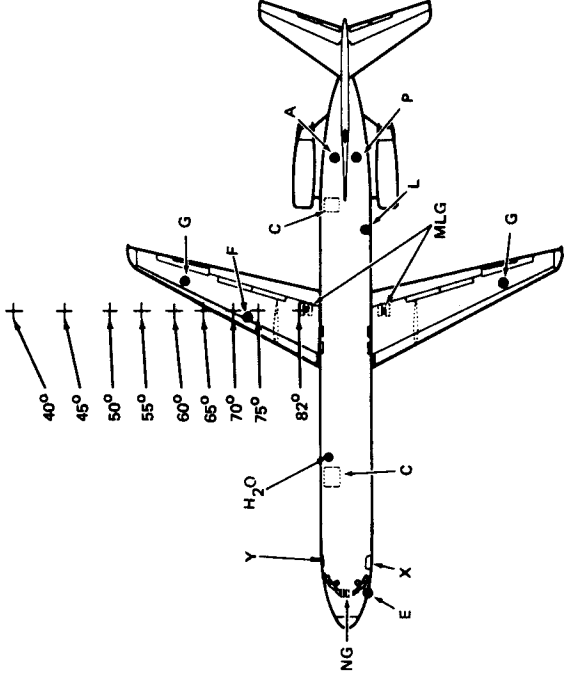

LEGEND

- | | | | |
|----|-------------------------------|-----|-------------------|
| A. | PRECONDITIONED AIR | L. | LAVATORY (1) |
| B. | MAIN CARGO DOOR (NONE) | MLG | MAIN LANDING GEAR |
| C. | FWD, AFT CARGO DOORS | NG | NOSE LANDING GEAR |
| E. | ELECTRICAL - GROUND POWER | P. | PNEUMATIC POWER |
| F. | PRESSURE REFUELING POINTS (1) | X. | PASSENGER DOOR |
| G. | GRAVITY REFUELING POINTS (2) | | |
- H₂O POTABLE WATER (2)

TURNING RADIUS POINTS, +
82°, 75°, 70°, 65°, 60°, 55°, 50°, 45°, 40°

9.0 SCALE DRAWINGS
DC-9-51

SCALE: 1 TO 1000

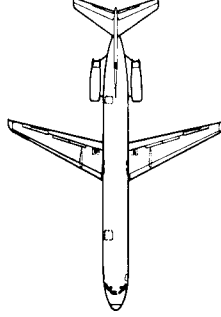

*SEE OTHER PAGES IN THIS SECTION FOR SERVICE POINT LOCATIONS.

LEGEND

- | | | | |
|----|-------------------------------|-----|-------------------|
| A. | PRECONDITIONED AIR | L. | LAVATORY (1) |
| B. | MAIN CARGO DOOR (NONE) | MLG | MAIN LANDING GEAR |
| C. | FWD, AFT CARGO DOORS | NG | NOSE LANDING GEAR |
| E. | ELECTRICAL – GROUND POWER | P. | PNEUMATIC POWER |
| F. | PRESSURE REFUELING POINTS (1) | X. | PASSENGER DOOR |
| G. | GRAVITY REFUELING POINTS (2) | | |
- H₂O POTABLE WATER (2)

TURNING RADIUS POINTS, +
82°, 75°, 70°, 65°, 60°, 55°, 50°, 45°, 40°

9.0 SCALE DRAWINGS

DC-9-51