



MD-90-30 AIRPLANE CHARACTERISTICS FOR AIRPORT PLANNING

**REVISION A
OCTOBER 2002**

BOEING COMMERCIAL AIRPLANES

Not Subject to US Export Administration Regulations (EAR), (15 C.F.R. Parts 730-774)
or US International Traffic in Arms Regulations (ITAR), (22 C.F.R. Parts 120-130).

MDC K9099

i



This page intentionally left blank



This document will be revised periodically to reflect the significant changes to the airplane design which would affect airport planning requirements. Revisions will also be made when other configurations of this airplane are developed.

Since aircraft operational environment varies greatly at each airport, use of the data contained in this document with regard to aircraft/airport operational and safety aspects is at the discretion of and becomes the responsibility of the user.

This document can also be viewed on the Internet at the following address:

www.boeing.com/airports

Revisions to this document will be posted at this website.



This page intentionally left blank



This page intentionally left blank



CONTENTS

Section	Page
1.0	SCOPE 1-1
1.1	Purpose 1-1
1.2	Introduction 1-2
2.0	AIRPLANE DESCRIPTION 2-1
2.1	General Airplane Characteristics 2-1
2.2	General Airplane Dimensions 2-3
2.3	Ground Clearances 2-4
2.4	Interior Arrangements 2-5
2.5	Cabin Cross Section 2-7
2.6	Lower Compartment (No Containers) 2-9
2.7	Door Clearances 2-10
2.7.1	Lower Forward, Mid and Aft Cargo Door Clearances 2-10
2.7.2	Passenger Entrance and Service Door Clearances 2-11
2.7.3	Main Entrance Stairway Clearances 2-12
2.7.4	Forward Passenger Door Opening Clearances 2-13
2.7.5	Aft Service Door Clearances 2-14
2.7.6	Aft Pressure Bulkhead Door Opening Clearances 2-15
2.7.7	Ventral Stair Clearances 2-16
3.0	AIRPLANE PERFORMANCE 3-1
3.1	General Information 3-1
3.2	Payload-Range 3-2
3.3	FAR Takeoff Runway Length Requirements 3-4
3.4	FAR Landing Runway Length Requirements 3-5
4.0	GROUND MANEUVERING 4-1
4.1	General Information 4-1
4.2	Turning Radii, No Slip Angle 4-2
4.3	Minimum Turning Radii 4-3
4.4	Visibility from Cockpit in Static Position 4-4
4.5	Runway and Taxiway Turn Paths 4-5
4.5.1	More than 90-Degree Turn - Runway to Taxiway 4-5
4.5.2	90-Degree Turn - Runway to Taxiway 4-6
4.5.3	90-Degree Turn - Taxiway to Taxiway - Nose Gear Tracking Beyond Taxiway Centerline 4-7
4.5.4	90-Degree Turn - Taxiway to Taxiway - Cockpit Tracks Centerline to Centerline 4-8
4.6	Runway Holding Bay (Apron) 4-9



CONTENTS (CONTINUED)

Section		Page
5.0	TERMINAL SERVICING	5-1
5.1	Airplane Servicing Arrangement (Typical)	5-1
5.2	Terminal Operations, Turnaround Station	5-2
5.3	Terminal Operations, En Route Station	5-3
5.4	Ground Service Connections	5-4
5.5	Engine Starting Pneumatic Requirements	5-8
5.6	Ground Pneumatic Power Requirements	5-9
5.7	Preconditioned Airflow Requirements	5-10
5.8	Ground Towing Requirements	5-11
6.0	OPERATING CONDITIONS	6-1
6.1	Jet Engine Exhaust Velocities and Temperatures	6-1
6.1.1	Jet Engine Exhaust Velocity Contours, Breakaway Power	6-1
6.1.2	Jet Engine Exhaust Velocity Contours, Takeoff Power	6-2
6.1.3	Jet Engine Exhaust Velocity Contours, Idle Power	6-3
6.1.4	Jet Engine Exhaust Temperature	6-4
6.2	Airport and Community Noise	6-5
7.0	PAVEMENT DATA	7-1
7.1	General Information	7-1
7.2	Footprint	7-4
7.3	Maximum Pavement Loads	7-5
7.4	Landing Gear Loading on Pavement	7-6
7.5	Flexible Pavement Requirements, U.S. Corps of Engineers Design Method	7-9
7.6	Flexible Pavement Requirements, LCN Conversion	7-11
7.7	Rigid Pavement Requirements, Portland Cement Association Design Method	7-13
7.8	Rigid Pavement Requirements, LCN Conversion	7-15
7.8.1	Radius of Relative Stiffness (Table)	7-16
7.8.2	Rigid Pavement Requirements, LCN Conversion	7-17
7.8.3	Radius of Relative Stiffness (Other values of E and ℓ)	7-18
7.8.4	Effect of E and μ on ℓ Values	7-19
7.9	ACN-PCN Reporting System	7-20
7.9.1	Aircraft Classification Number (ACN) – Flexible Pavement	7-21
7.9.2	Aircraft Classification Number (ACN) – Flexible Pavement (168,500 lbs) ...	7-22
7.9.3	Aircraft Classification Number (ACN) – Rigid Pavement	7-23
7.9.4	Aircraft Classification Number (ACN) – Rigid Pavement (168,500 lbs)	7-24
7.9.5	Development of ACN Charts	7-25
7.9.6	Development of ACN Charts - Flexible Pavement	7-27
7.9.7	Development of ACN Charts - Rigid Pavement	7-28
8.0	POSSIBLE MD-90-30 DERIVATIVE AIRPLANES	8-1
9.0	SCALED DRAWINGS	9-1



1.0 SCOPE

1.1 Purpose

1.2 Introduction

OCTOBER 2002

MDC K9099

Not Subject to EAR or ITAR.
Copyright © 2023 Boeing. All Rights Reserved.



This page intentionally left blank



1.0 SCOPE

1.1 Purpose

This document provides, in a standardized format, airplane characteristics data for general airport planning. Since operational practices vary among airlines, specific data should be coordinated with the using airlines prior to facility design. Boeing Commercial Airplanes should be contacted for any additional information required.

The content of this document reflects the results of a coordinated effort by representatives of the following organizations:

Aerospace Industries Association
Airports Council International
Air Transport Association of America
International Air Transport Association



1.2 Introduction

This document conforms to NAS 3601. It provides Model MD-90-30 characteristics for airport operators, airlines, and engineering consultant organizations. Since airplane changes and available options may alter the information, the data presented herein must be regarded as subject to change. Similarly, for airplanes not yet certified, changes can be expected to occur.

NOTE:

This document has been partially revised to incorporate key information for the MD-90-30ER with a maximum ramp weight of 168,500 lbs (76,430kgs). The main change on the MD-90-30ER, in addition to the increase in maximum weight, is the addition of auxillary fuel tanks to the cargo compartment. Due to the fact that there were only two aircraft delivered in this higher weight configuration when production of the model ceased, only limited charts in this document have been revised for the MD-90-30ER.

For further information, contact:

Boeing Commercial Airplanes
Airport Technology, M/C 67-KR
P.O. Box 3707
Seattle, WA 98124-2207 USA

Telephone: 425-237-0126
Fax: 425-237-8281
Email: AirportTechnology@Boeing.com
Website: www.boeing.com/airports



2.0 AIRPLANE DESCRIPTION

2.1 General Airplane Characteristics

2.2 General Airplane Dimensions

2.3 Ground Clearances

2.4 Interior Arrangements

2.5 Cabin Cross Section

2.6 Lower Compartment

2.7 Door Clearances



This page intentionally left blank



2.0 AIRPLANE DESCRIPTION

2.1 General Airplane Characteristics

Maximum Design Taxi Weight (MTW). Maximum weight for ground maneuvering as limited by aircraft strength (MTOW plus taxi fuel).

Maximum Design Landing Weight (MLW). Maximum weight for landing as limited by aircraft strength and airworthiness requirements.

Maximum Design Takeoff Weight (MTOW). Maximum weight for takeoff as limited by aircraft strength and airworthiness requirements. (This is the maximum weight at start of the takeoff run.)

Operating Empty Weight (OEW). Weight of structure, power plant, furnishing, systems, unusable fuel and other usable propulsion agents, and other items of equipment that are considered part of a particular airplane configuration. OEW also includes certain standard items, personnel, equipment, and supplies necessary for full operations, excluding usable fuel and payload.

Maximum Design Zero Fuel Weight (MZFW). Maximum weight allowed before usable fuel and other specified usable agents must be loaded in defined sections of the aircraft as limited by strength and airworthiness requirements.

Maximum Payload. Maximum design zero fuel weight minus operational empty weight.

Maximum Seating Capacity. The maximum number of passengers certified or anticipated for certification.

Maximum Cargo Volume. The maximum space available for cargo.

Usable Fuel. Fuel available for aircraft propulsion



		MD-90-30	MD-90-30ER
MAXIMUM DESIGN TAXI WEIGHT	POUNDS	157,000	168,500
	KILOGRAMS	71,214	76,430
MAXIMUM DESIGN LANDING WEIGHT	POUNDS	142,000	142,000
	KILOGRAMS	64,410	64,410
MAXIMUM DESIGN TAKEOFF WEIGHT	POUNDS	156,000	168,000
	KILOGRAMS	70,760	76,204
OPERATING EMPTY WEIGHT	POUNDS	88,171	89,059
	KILOGRAMS	39,994	40,396
MAXIMUM DESIGN ZERO FUEL WEIGHT	POUNDS	130,000	132,000
	KILOGRAMS	58,967	59,874
MAXIMUM PAYLOAD	POUNDS	41,829	42,941
	KILOGRAMS	18,973	19,880
MAXIMUM SEATING CAPACITY	PASSENGERS	172	172
MAXIMUM CARGO VOLUME	CUBIC FEET	1,300	1,177
	CUBIC METERS	36.8	33.3
USABLE FUEL (6.7 LB PER GAL)	U.S. GALLONS	5,840	6,405
	LITERS	22,104	24,242
	POUNDS	39,128	42,897
	KILOGRAMS	17,748	19,457

2.1 GENERAL AIRPLANE CHARACTERISTICS MODEL MD-90-30/-30ER

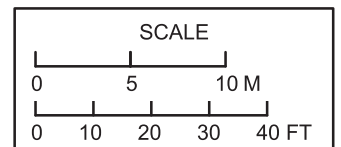
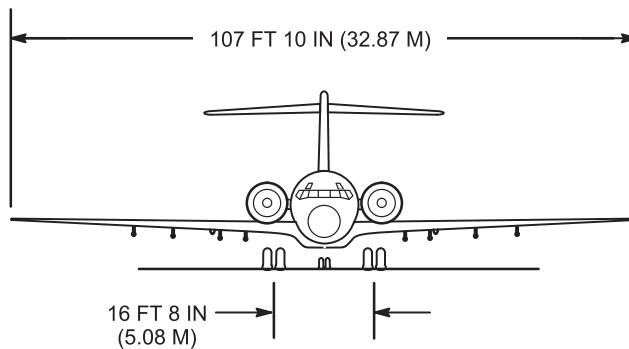
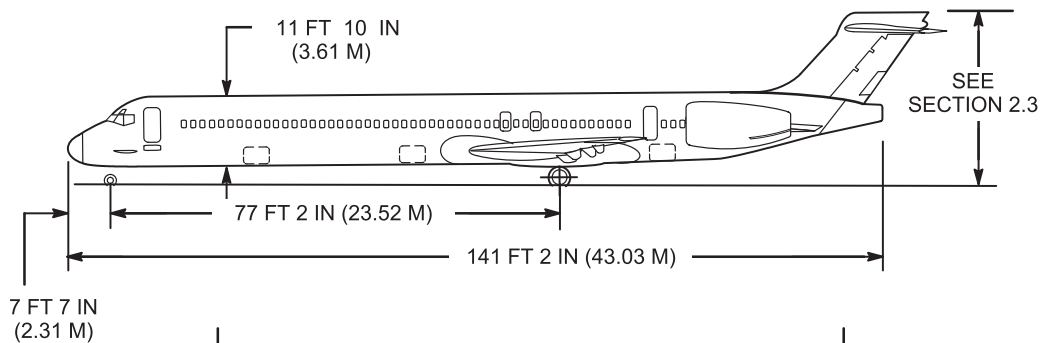
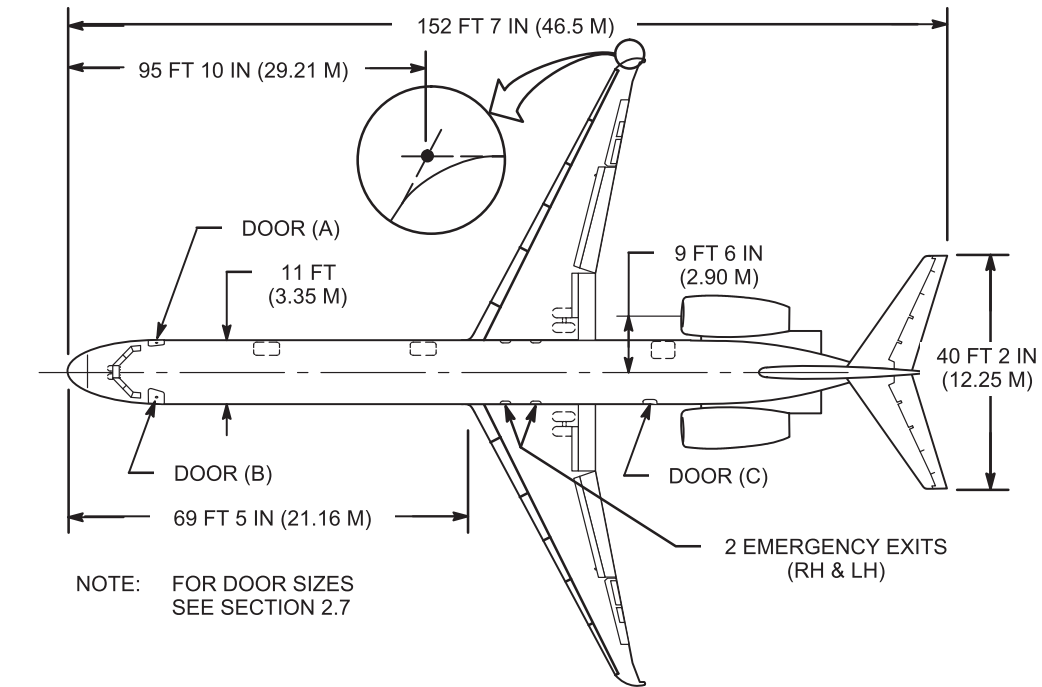

2.2 GENERAL AIRPLANE DIMENSIONS MODEL MD-90-30/-30ER

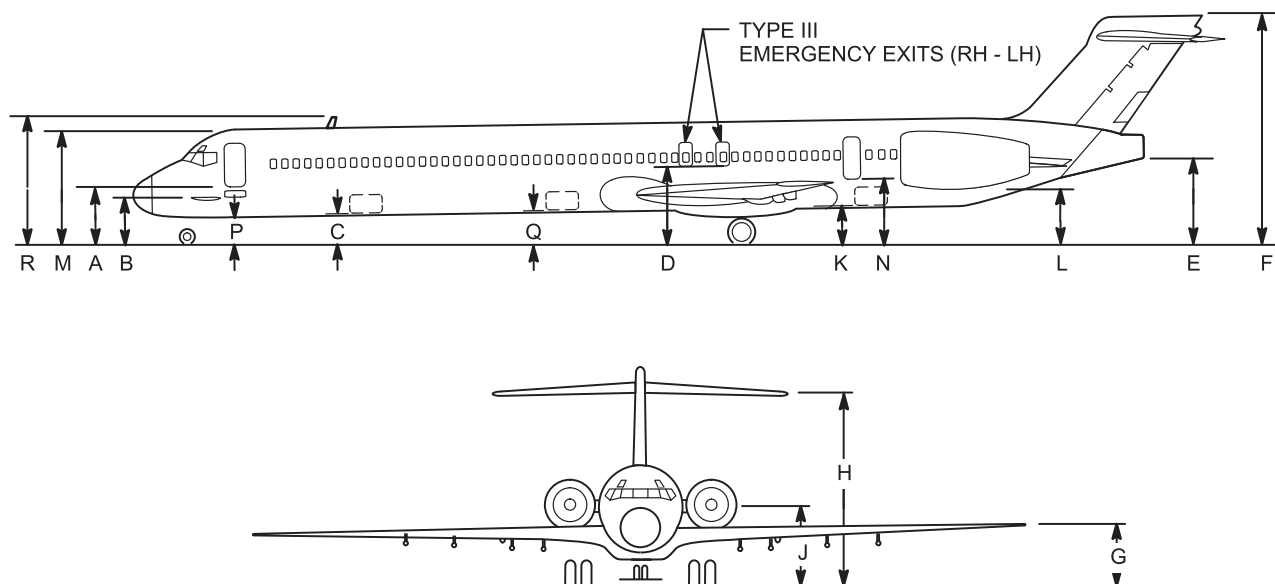

LETTER CODE	MAXIMUM		MINIMUM	
	FT-IN	METERS	FT-IN	METERS
A	8-0	2.4	7-4	2.2
B	6-5	2.0	5-5	1.6
C	4-5	1.3	3-10	1.2
D	10-8	3.3	10-4	3.1
E	12-0	3.7	11-3	3.4
F	31-2	9.5	30-5	9.3
G	8-10	2.7	8-4	2.5
H	27-5	8.4	26-8	8.1
J	1-5	3.5	10-10	3.3
K	5-5	1.6	4-11	1.5
L	7-1	2.2	6-6	2.0
M	15-7	4.7	14-11	4.5
N	9-1	2.8	8-8	2.6
P	3-8	1.1	3-1	0.9
Q	4-8	1.4	4-3	1.3
R	17-0	5.2	16-5	5.0

NOTES: VALUES APPLY TO STATIC AIRCRAFT ON A FLAT, LEVEL SURFACE.

IT IS RECOMMENDED THAT ±3 INCHES BE ALLOWED FOR VERTICAL EXCURSIONS DUE TO LOADING, VARYING STRUT AND TIRE INFLATIONS, PAVEMENT UNEVENNESS, ETC.

2.3 GROUND CLEARANCES MODEL MD-90-30/-30ER

MIXED CLASS

158 PASSENGERS, 4/5-ABREAST SEATING
 12 SEATS ON 36-IN. (91.4 CM) PITCH
 14 SEATS ON 32-IN. (81.3 CM) PITCH
 132 SEATS ON 31-IN. (78.7 CM) PITCH

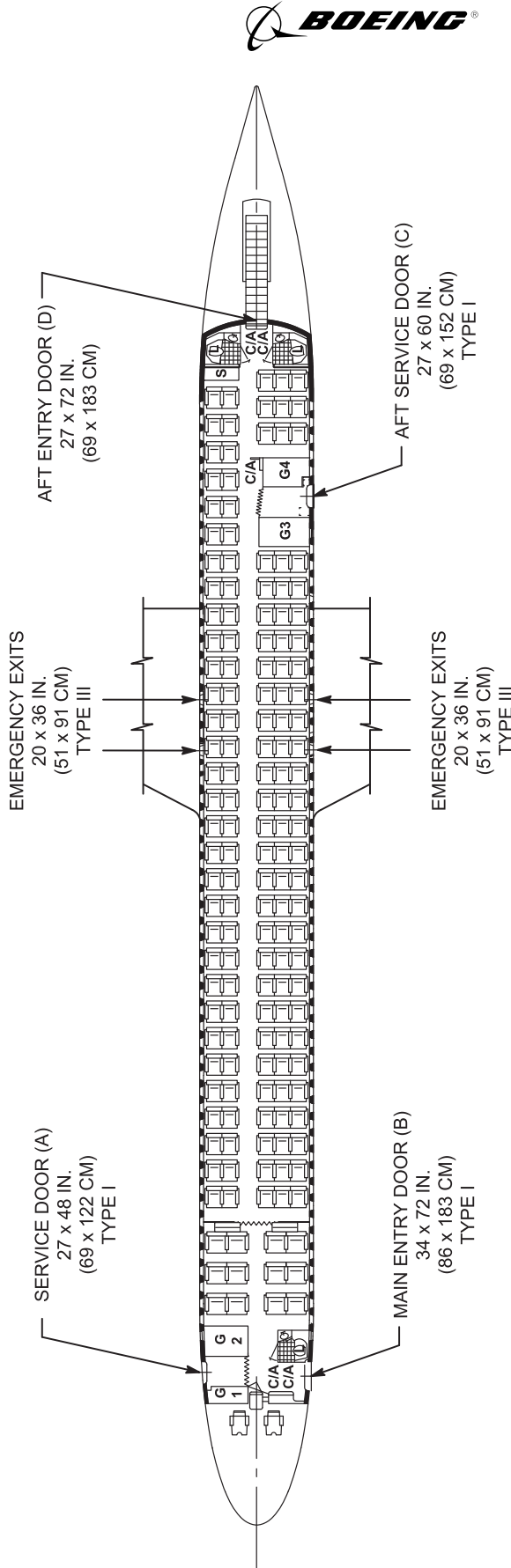

NOTE: MAXIMUM OF 172 PASSENGERS, 5-ABREAST SEATING AVAILABLE

SYMBOLS
 C/A CABIN ATTENDANT SEAT
 G GALLEY
 L LAVATORY
 S STORAGE

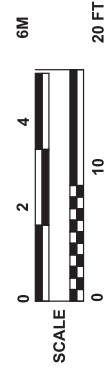

2.4 INTERIOR ARRANGEMENTS
4.1 PASSENGERS -- MIXED CLASS
MODEL MD-90-30/-30ER



ALL ECONOMY

163 PASSENGERS, 5-ABREAST SEATING
 19 SEATS ON 32-IN. (81.3 CM) PITCH
 144 SEATS ON 31-IN. (78.7 CM) PITCH

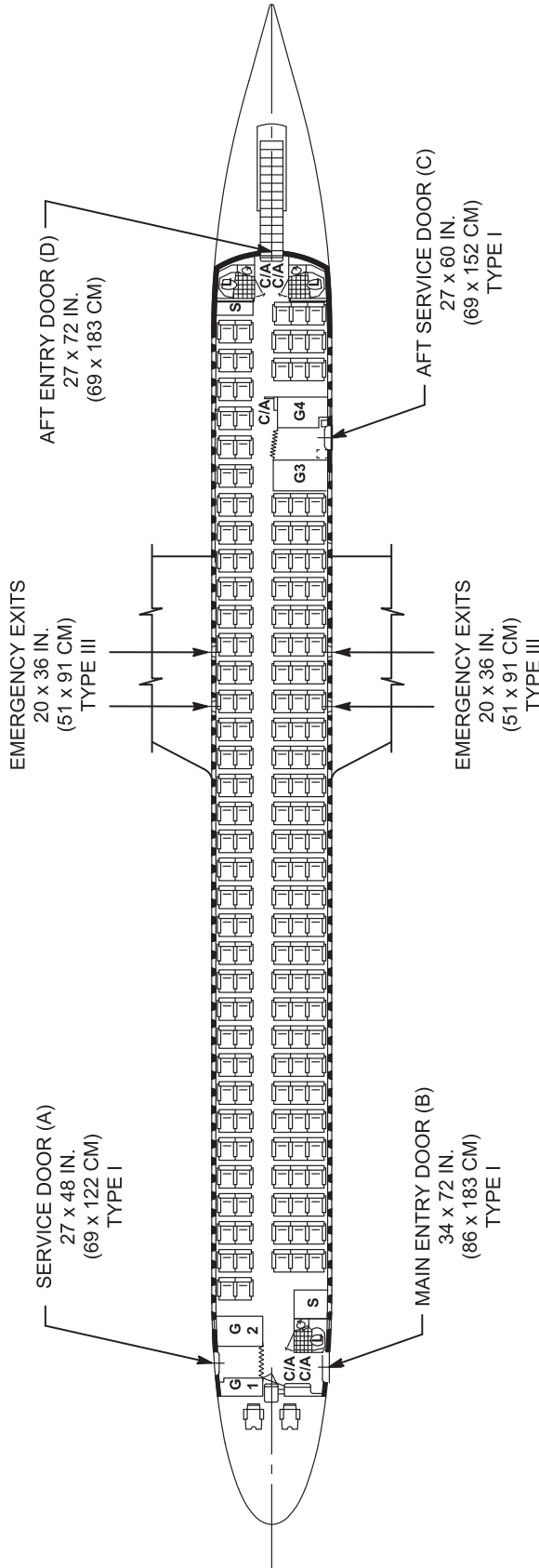

NOTE: MAXIMUM OF 172 PASSENGERS, 5-ABREAST SEATING AVAILABLE

SYMBOLS

- C/A CABIN ATTENDANT SEAT
- G GALLEY
- L LAVATORY
- S STORAGE

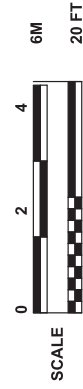

2.4 INTERIOR ARRANGEMENTS
.4.2 PASSENGERS -- ALL ECONOMY
MODEL MD-90-30/-30ER

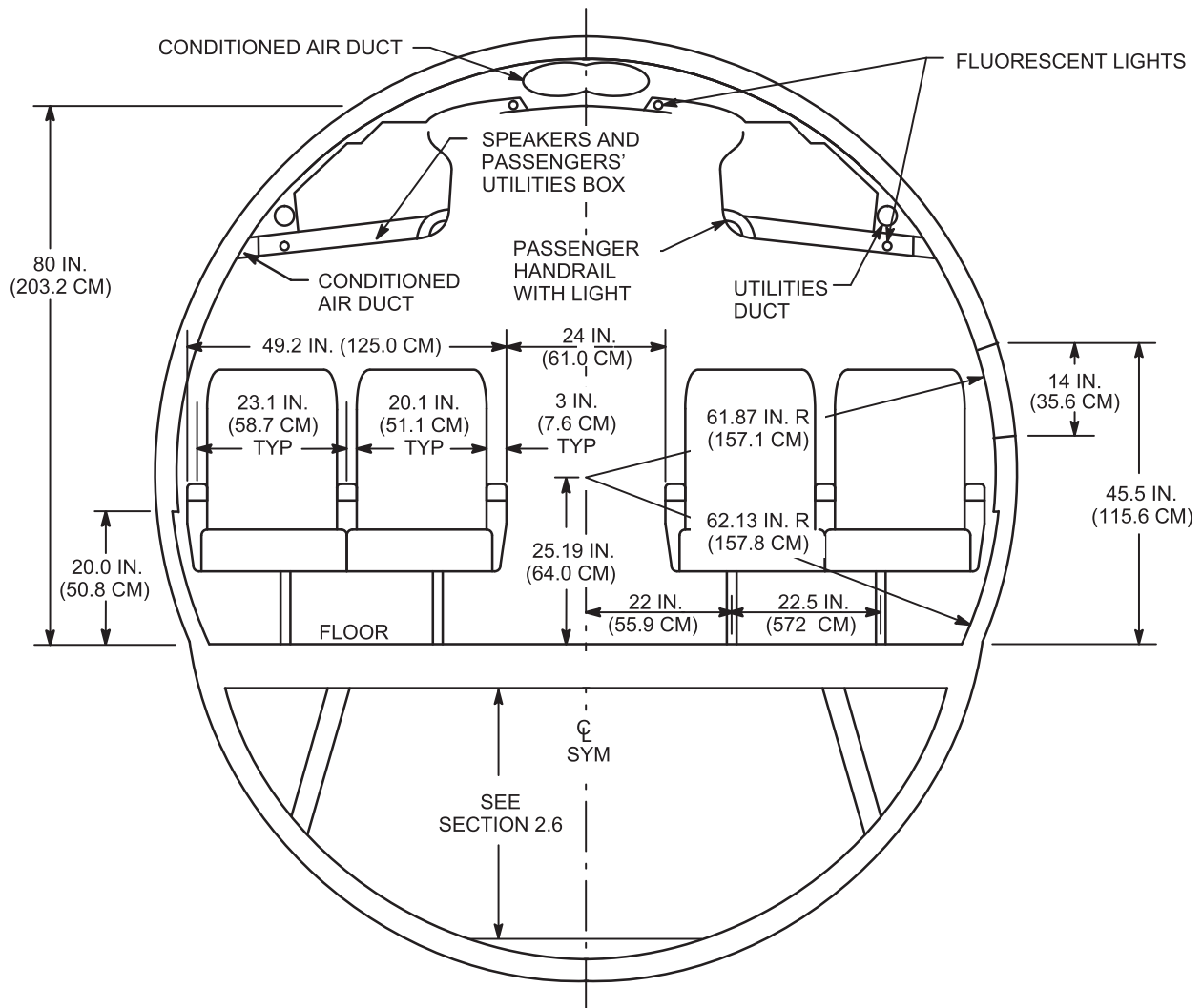

2.5 PASSENGER CABIN CROSS SECTION
2.5.1 FIRST CLASS
MODEL MD-90-30/30ER

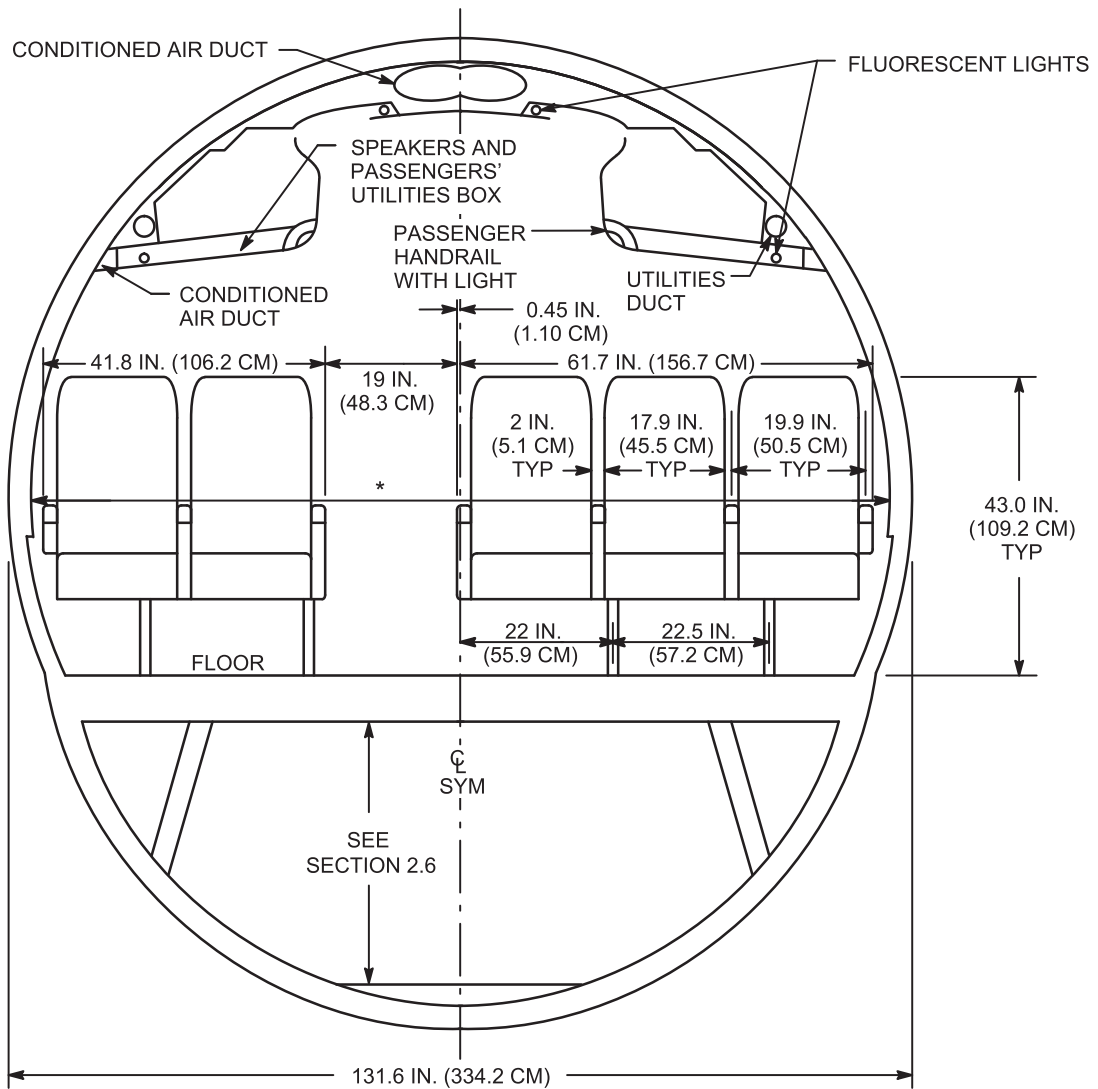

* TRIM TO TRIM 123.7 IN. (314.2 CM)

2.5 PASSENGER CABIN CROSS SECTION
2.5.2 COACH CLASS
MODEL MD-90-30/-30ER

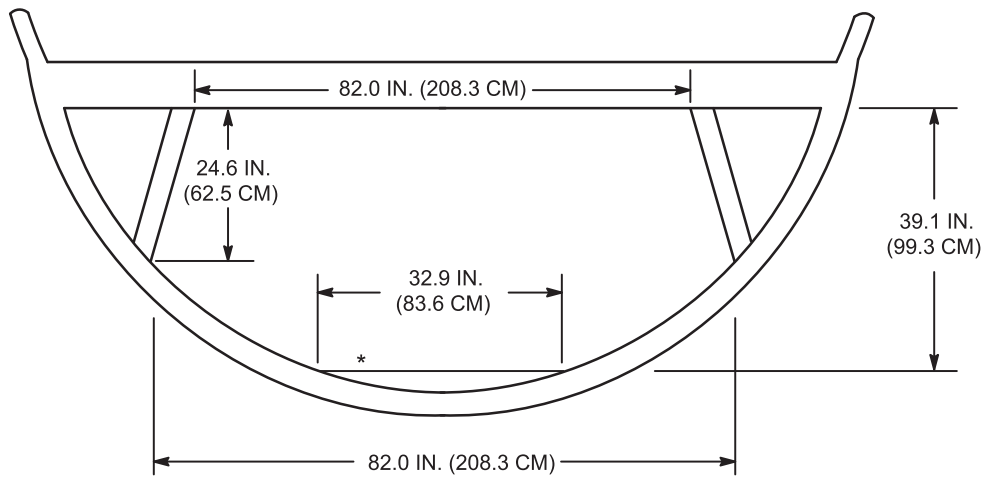
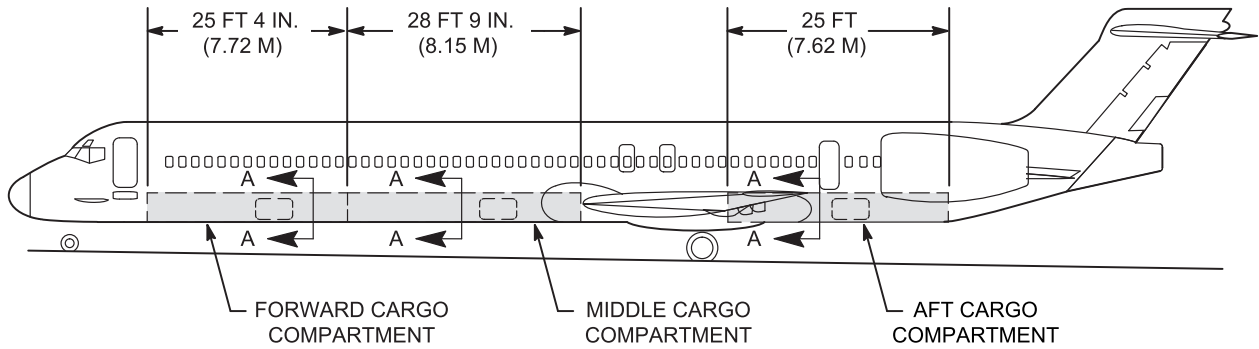

* FLAT FLOOR STANDARD IN THE
CONSTANT FUSELAGE SECTION
(NOT FLAT AFT OF REAR CARGO DOOR)

SECTION A-A

MODEL	FORWARD CARGO COMPARTMENT	MIDDLE CARGO COMPARTMENT	AFT CARGO COMPARTMENT	TOTAL BULK CARGO
MD-90-30	434 FT ³ (12.3 M ³)	466 FT ³ (13.2 M ³)	400 FT ³ (11.3 M ³)	1300 FT ³ (36.8 M ³)
MD-90-30ER	434 FT ³ (12.3 M ³)	343 FT ³ (9.7 M ³)	400 FT ³ (11.3 M ³)	1177 FT ³ (33.3 M ³)

**2.6 LOWER COMPARTMENTS (BULK CARGO)
MODEL MD-90-30/-30ER**

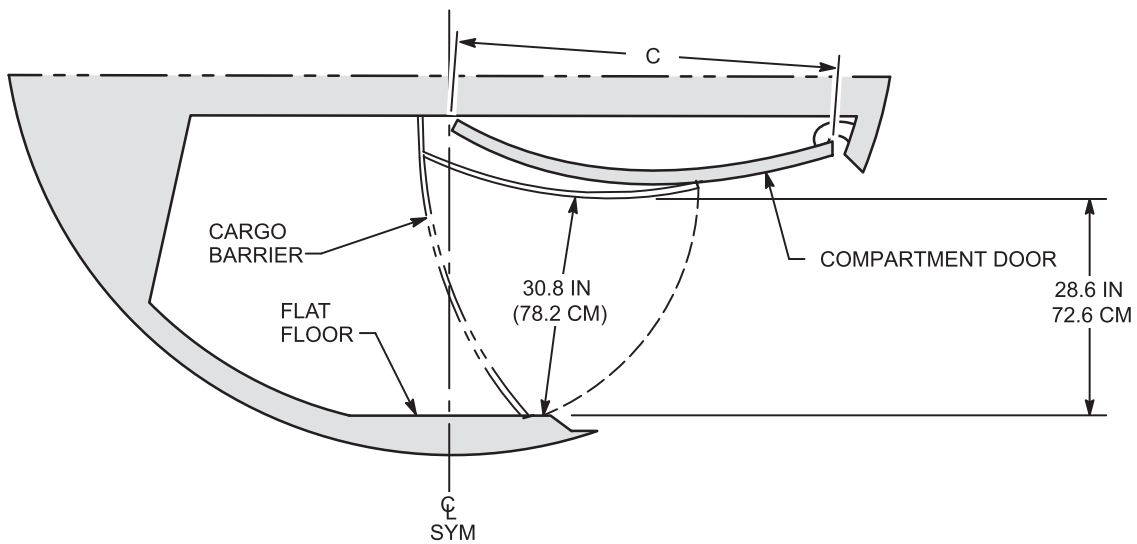
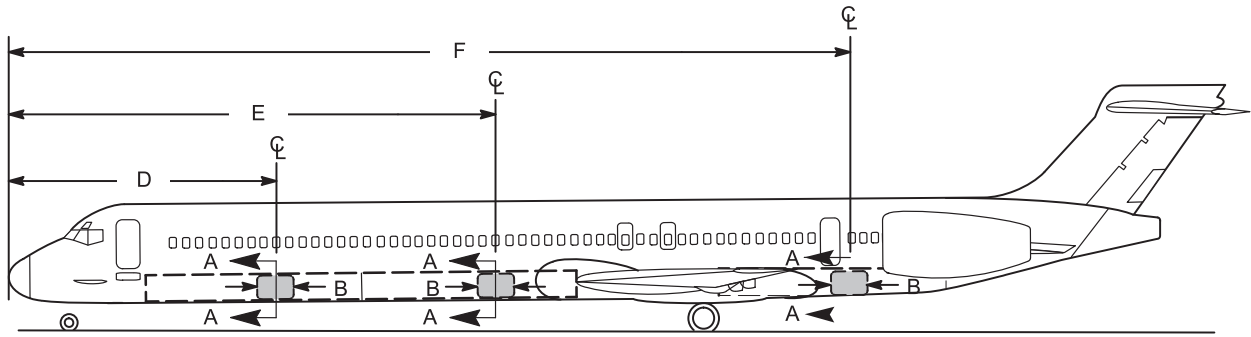

SECTION A-A

DOOR TYPE	DOOR SIZE (B x C)	DISTANCE AFT OF NOSE TO DOOR CL (D,E,F)
FWD CARGO DOOR	ALL ARE 53 x 50 IN. (134.6 x 127 CM)	(D) 32 FT 7.5 IN. (9.94 M)
MID CARGO DOOR		(E) 59 FT 6.5 IN. (18.15 M)
AFT CARGO DOOR		(F) 102 FT 9.5 IN. (31.33 M)

2.7 DOOR CLEARANCES
2.7.1 LOWER FORWARD, MID, AND AFT CARGO
DOOR CLEARANCES
MODEL MD-90-30/-30ER

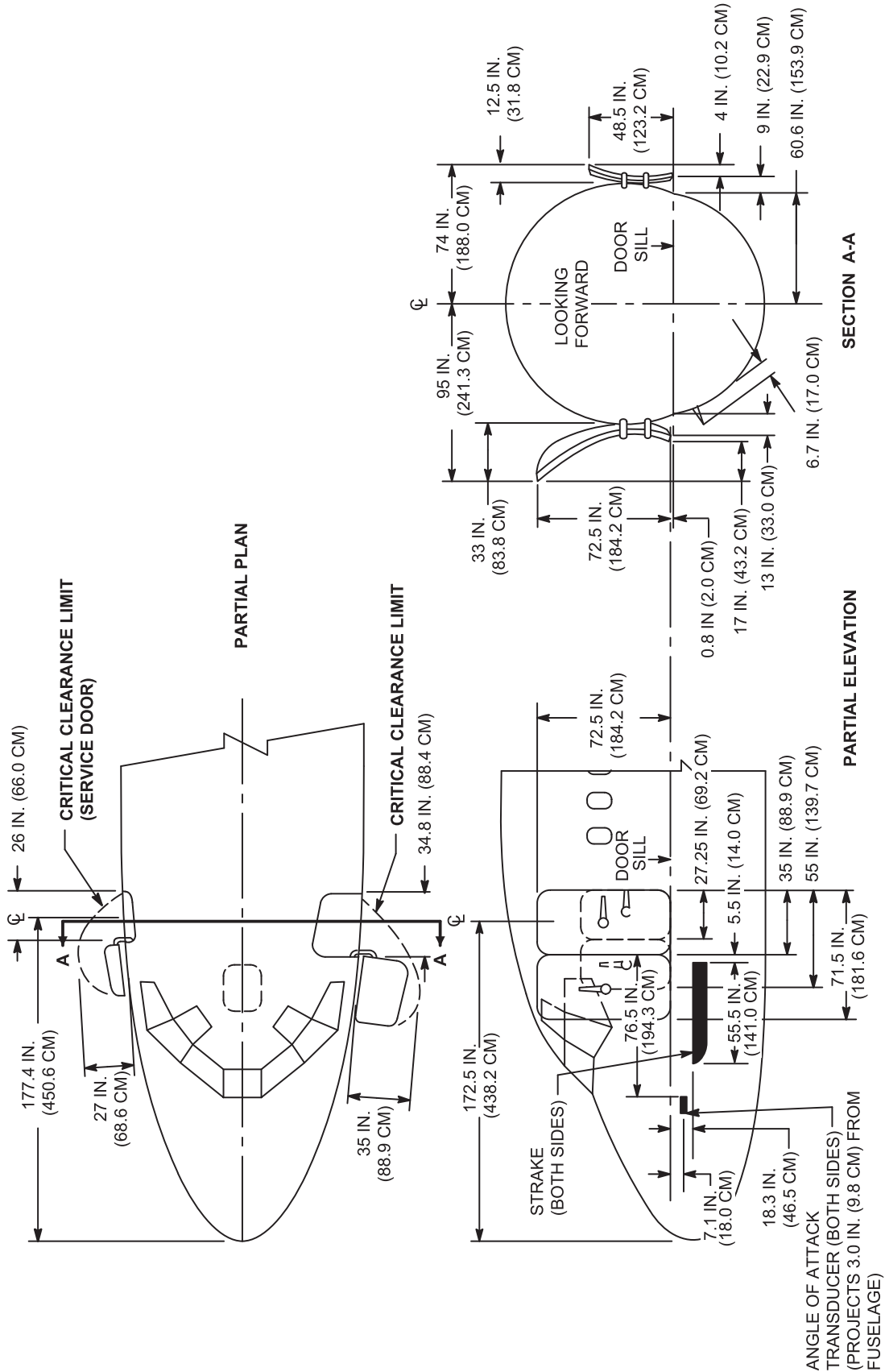

2.7 DOOR CLEARANCES
2.7.2 PASSENGER ENTRANCE AND SERVICE DOOR CLEARANCES
MODEL MD-90-30/-30ER

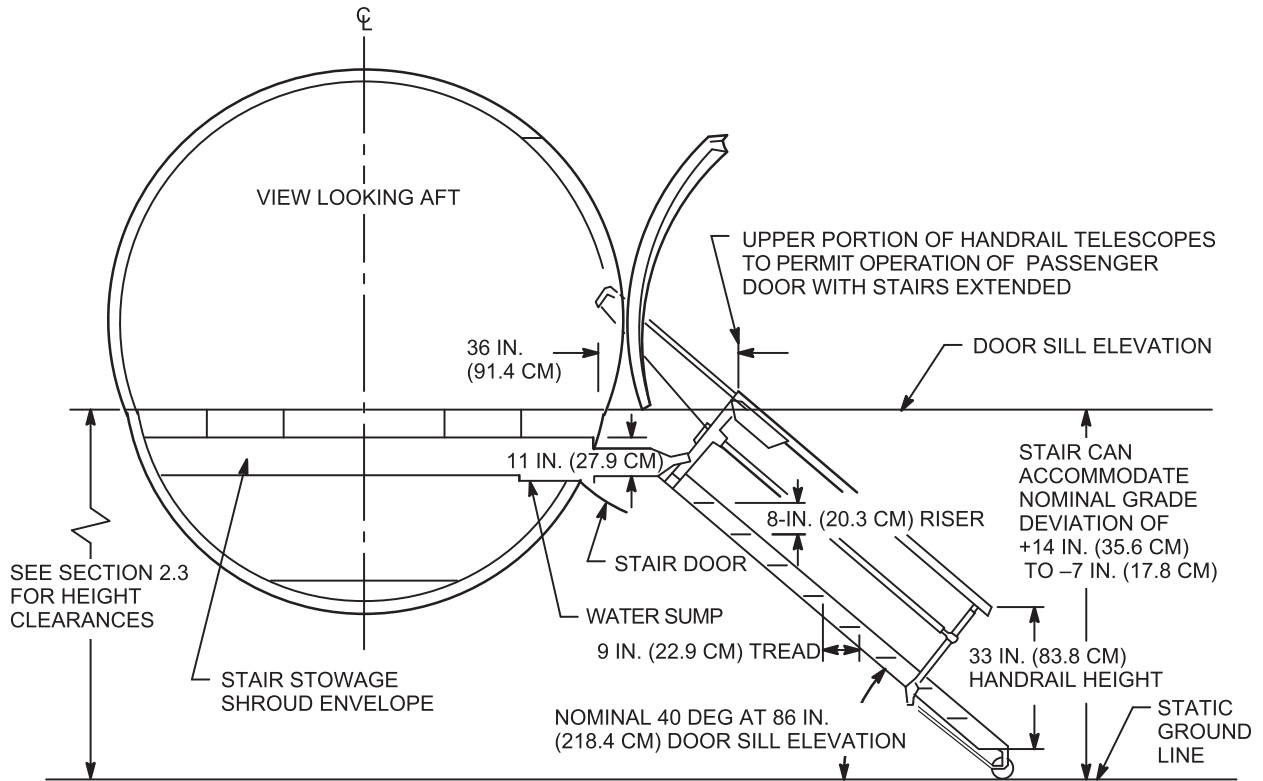

2.7 DOOR CLEARANCES
2.7.3 MAIN ENTRANCE STAIRWAY CLEARANCES
MODEL MD-90-30/-30ER

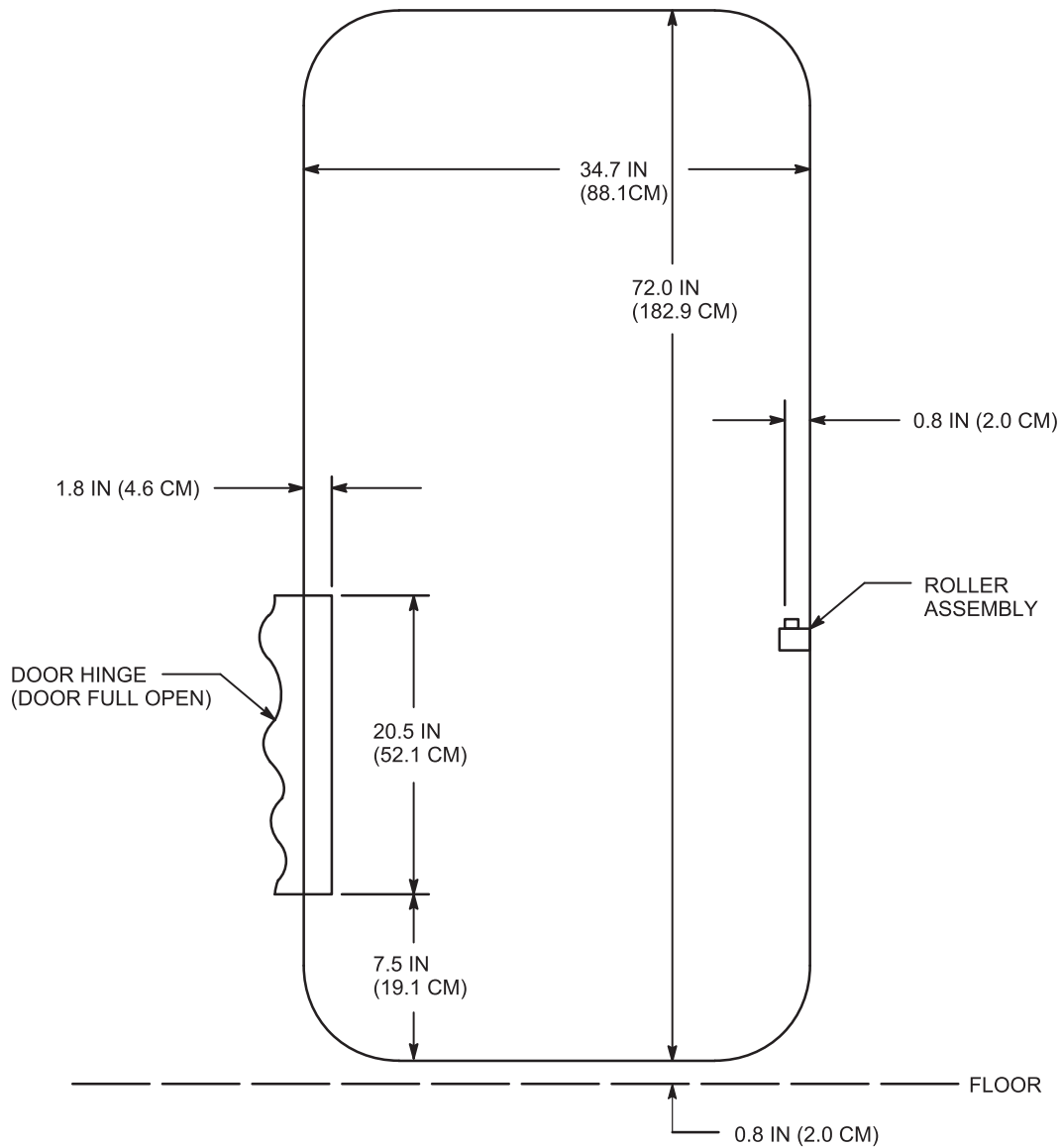

2.7 DOOR CLEARANCES
2.7.4 FORWARD PASSENGER DOOR OPENING
MODEL MD-90-30/-30ER

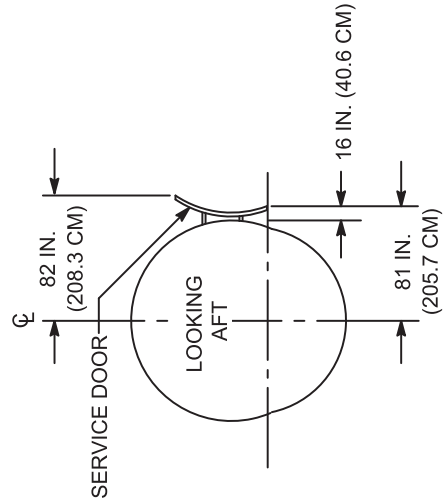
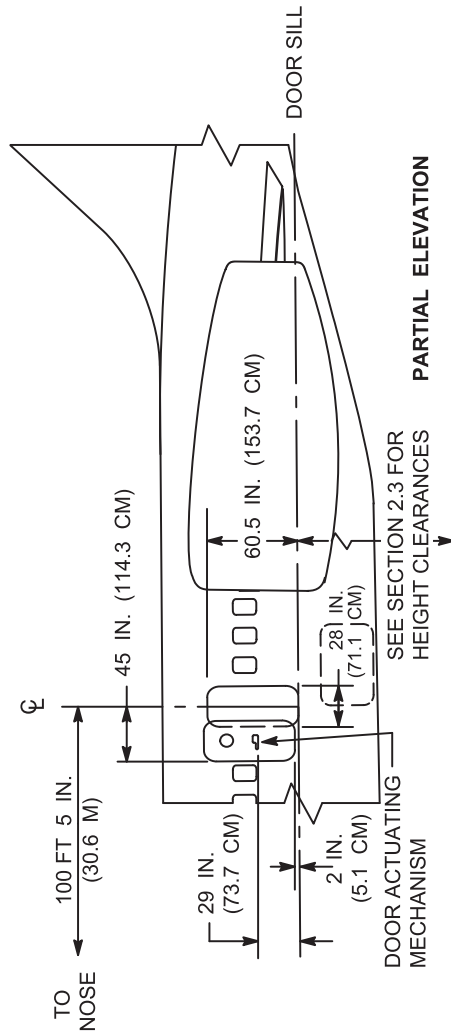
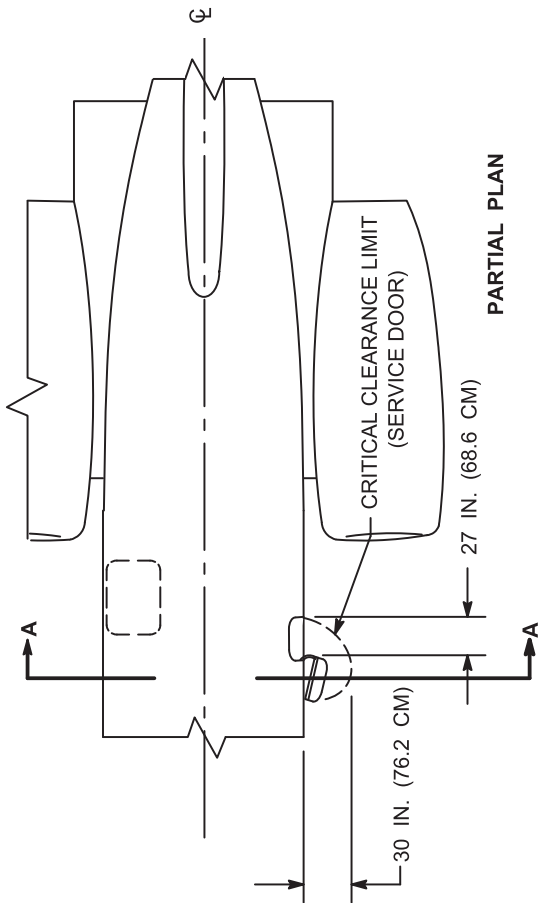

2.7 DOOR CLEARANCES
2.7.5 AFT SERVICE DOOR CLEARANCES
MODEL MD-90-30/-30ER

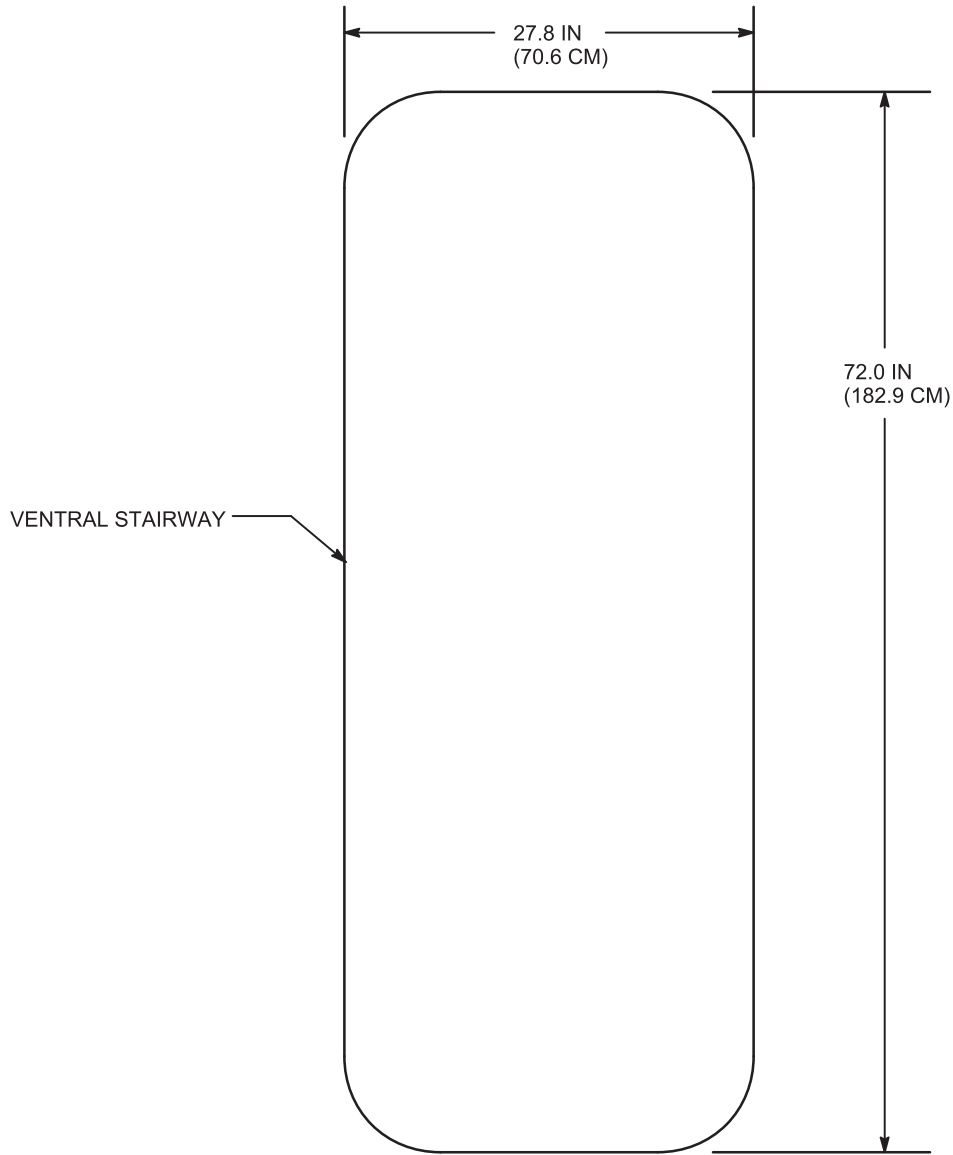

2.7 DOOR CLEARANCES
2.7.6 AFT PRESSURE BULKHEAD DOOR OPENING CLEARANCES
MODEL MD-90-30/-30ER

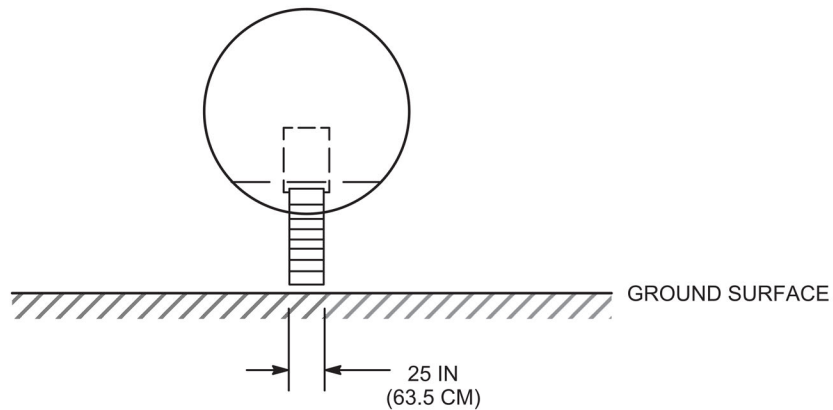
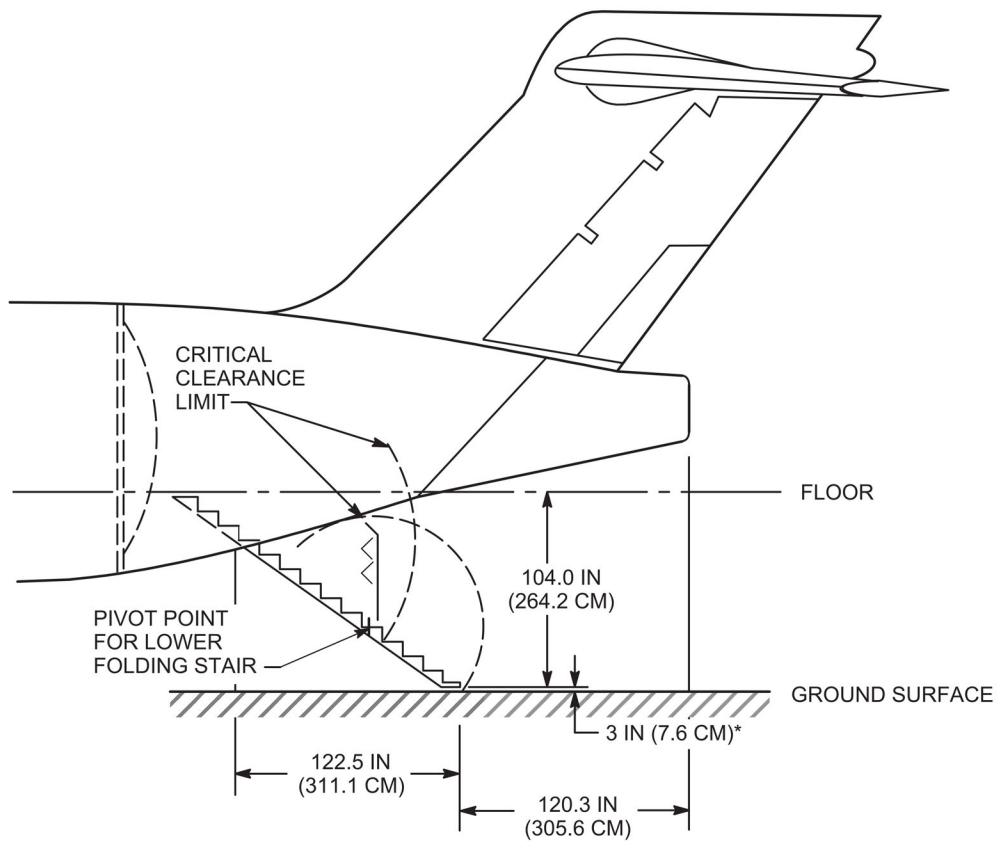

*VARIES WITH WEIGHT, C.G. LOCATION,
AND LANDING GEAR STRUT COMPRESSION

2.7 DOOR CLEARANCES
2.7.7 VENTRAL STAIR CLEARANCES
MODEL MD-90-30/-30ER



3.0 AIRPLANE PERFORMANCE

3.1 General Information

3.2 Payload-Range

3.3 FAR Takeoff Runway Length Requirements

3.4 FAR Landing Runway Length Requirements



This page intentionally left blank



3.0 AIRPLANE PERFORMANCE

3.1 General Information

Figures 3.2.1 and 3.2.2 present payload-range information for a specific Mach number cruise at the fuel reserve condition shown.

Figures 3.3.1 through 3.4.2 represent FAR takeoff and landing field length requirements for FAA certification.

Standard day temperatures for the altitudes shown are tabulated below:

ELEVATION		STANDARD DAY TEMPERATURE	
FEET	METERS	°F	°C
0	0	59.0	15.0
2,000	610	51.9	11.1
4,000	1,220	44.7	7.1
6,000	1,830	37.6	3.1
8,000	2,440	30.5	-0.8

Note: These data are provided for information only and are not to be used for flight planning purposes.

For specific performance data/analysis, contact the using airline or Airport Technology at:

Attention: Airport Technology
Telephone: 425-237-0126
Fax: 425-237-8281
Email: AirportTechnology@Boeing.com
Website: www.boeing.com/airports



STANDARD DAY
NO WIND
OEW 88,175 LB
V2500-D5 ENGINES

**NOT TO BE USED FOR
FLIGHT PLANNING PURPOSES**

NOTE: RESERVES BASED ON
FAR 121.639
200 N MI DISTANCE
TO ALTERNATE

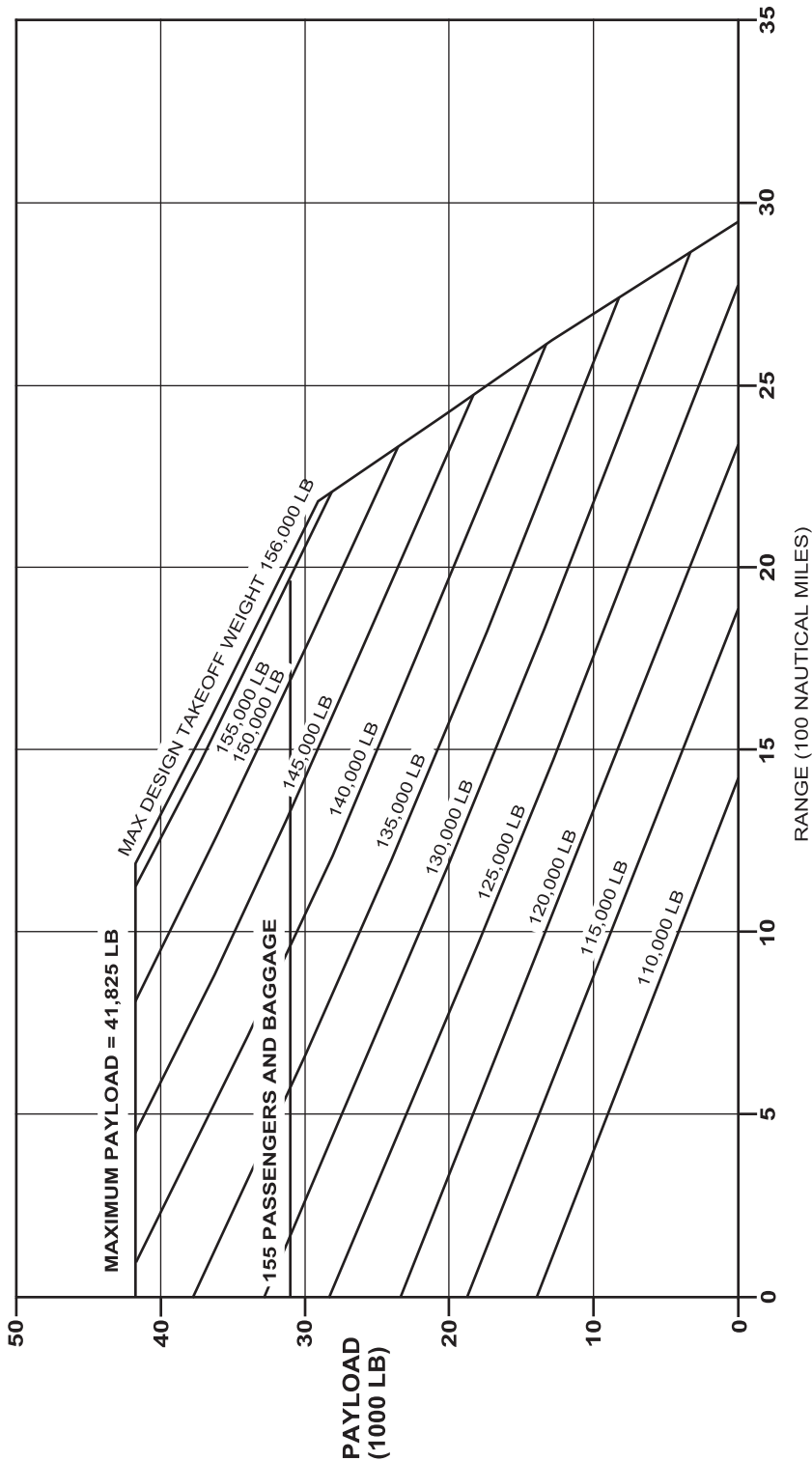

3.2 PAYLOAD-RANGE
3.2.1 PAYLOAD--RANGE FOR TYPICAL LONG-RANGE CRUISE AT 31,000/35,000 FT STEP
MODEL MD-90-30/-30ER



STANDARD DAY
 NO WIND
 OEW 39,996 KG
 V2500-D5 ENGINES

**NOT TO BE USED FOR
 FLIGHT PLANNING PURPOSES**

NOTE: RESERVES BASED ON
 FAR 121.639
 200 N MI DISTANCE
 TO ALTERNATE

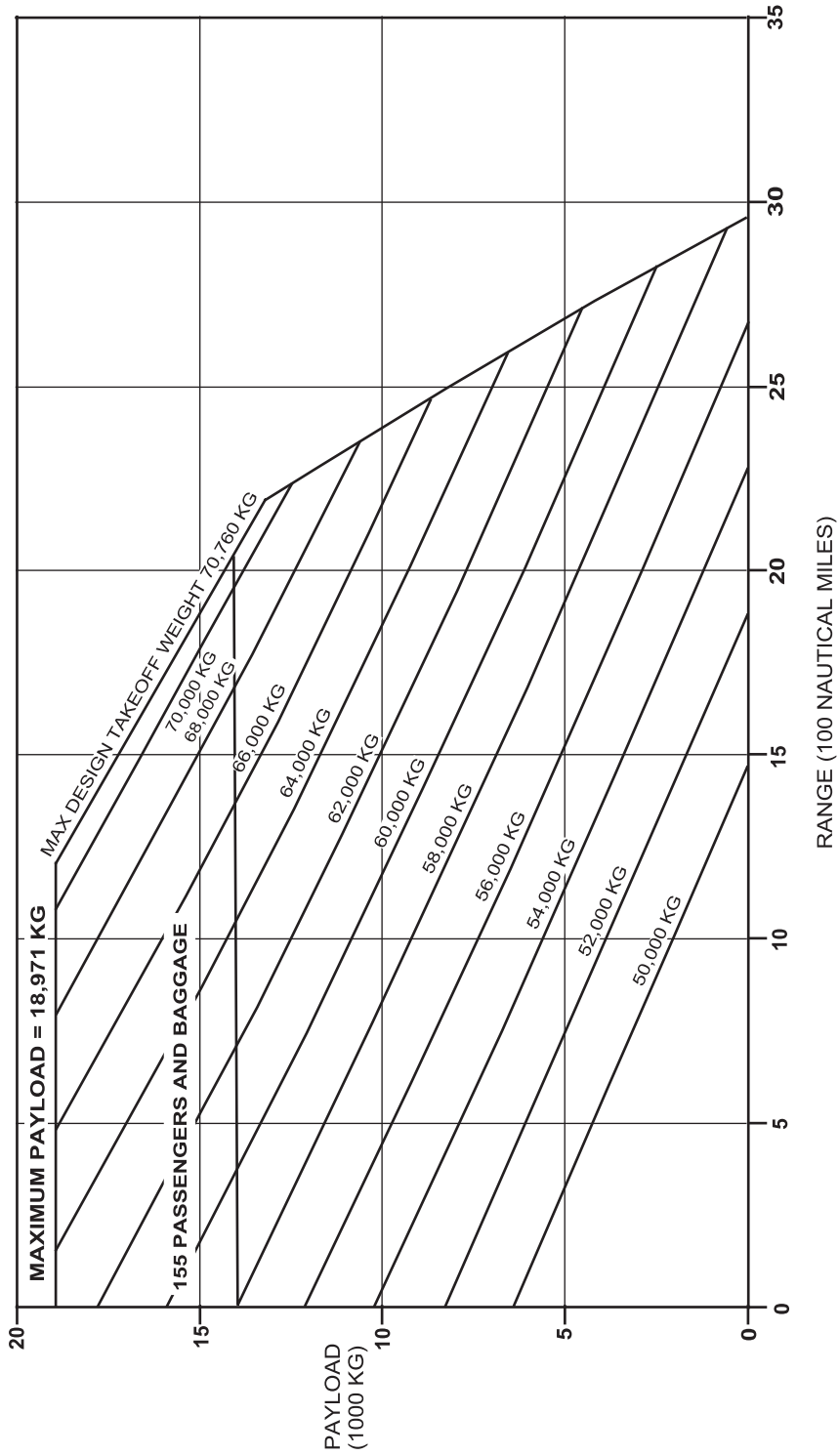

**3.2 PAYLOAD-RANGE
 3.2.2 PAYLOAD--RANGE FOR TYPICAL LONG-RANGE CRUISE AT 9,449/10,668 METER STEP
 MODEL MD-90-30/-30ER**



COORDINATE WITH USING AIRLINE FOR SPECIFIC REQUIREMENTS PRIOR TO FACILITY DESIGN

NOT TO BE USED FOR FLIGHT PLANNING PURPOSES

NOTES: V2500--D5 ENGINES
NORMAL TAKEOFF THRUST AND ART
ZERO RUNWAY GRADIENT
ZERO WIND

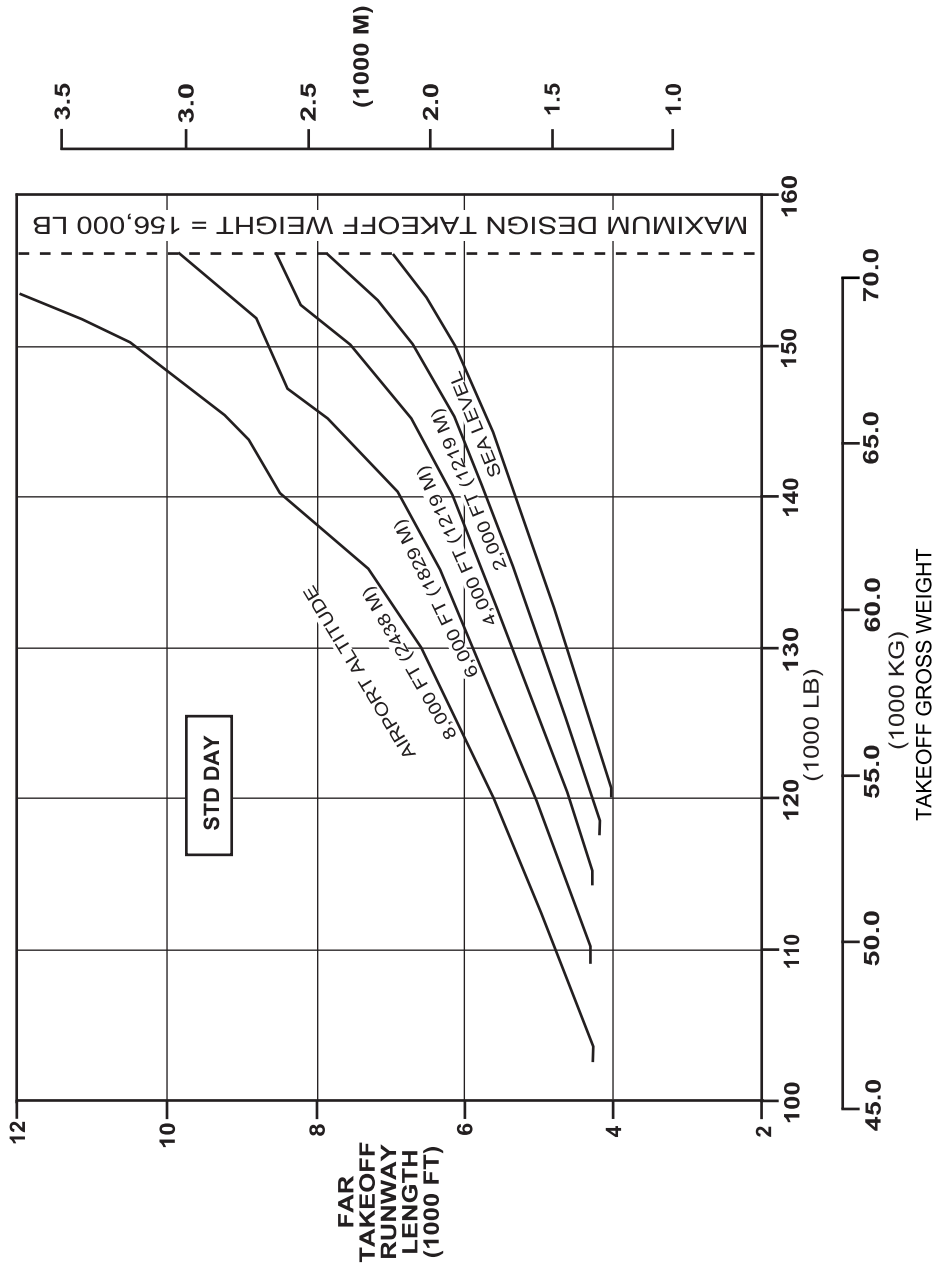

3.3 FAR TAKEOFF RUNWAY LENGTH REQUIREMENTS
3.3.1 STANDARD DAY
MODEL MD-90-30/-30ER



NOTE: V2500--D5 ENGINES
 NORMAL TAKEOFF THRUST AND ART
 ZERO RUNWAY GRADIENT
 ZERO WIND

NOT TO BE USED FOR
 FLIGHT PLANNING PURPOSES

COORDINATE WITH USING AIRLINE FOR
 SPECIFIC REQUIREMENTS PRIOR TO
 FACILITY DESIGN

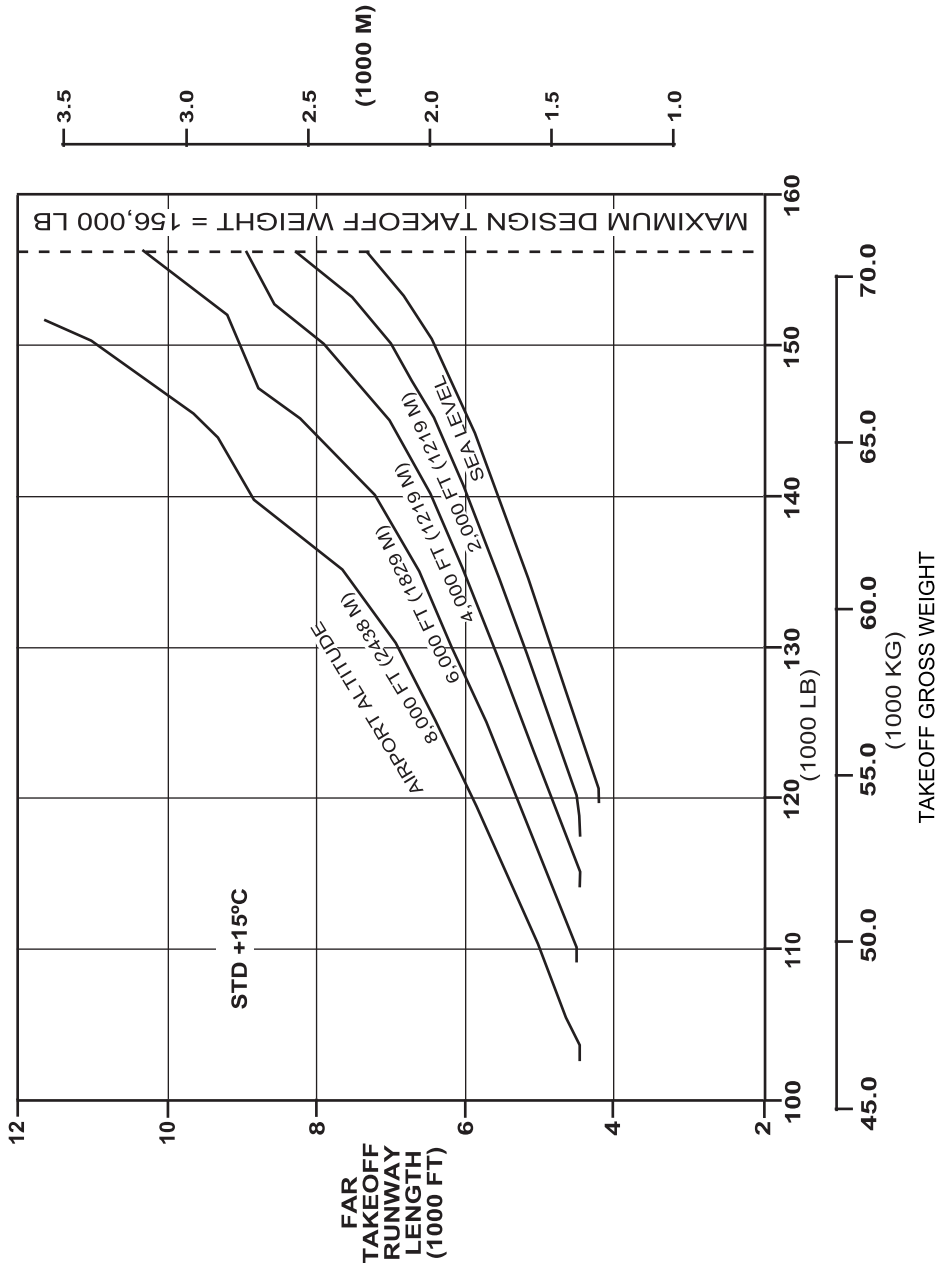

3.3 FAR TAKEOFF RUNWAY LENGTH REQUIREMENTS
3.3.2 STANDARD DAY + 15°C
MODEL MD-90-30/-30ER



$V_{app} = 1.3V_s$ FAR
 = (DRY AND WET RUNWAY)
 V_{app} IS APPROACH VELOCITY
 V_s IS APPROACH VELOCITY

NOT TO BE USED FOR
 FLIGHT PLANNING PURPOSES

- NOTES:
- STANDARD DAY
 - 3-DEGREE GLIDESLOPE
 - SLATS EXTENDED
 - ZERO WIND AT 50 FT HEIGHT
 - ZERO RUNWAY GRADIENT
 - COORDINATE WITH USING AIRLINE FOR SPECIFIC REQUIREMENTS PRIOR TO FACILITY DESIGN

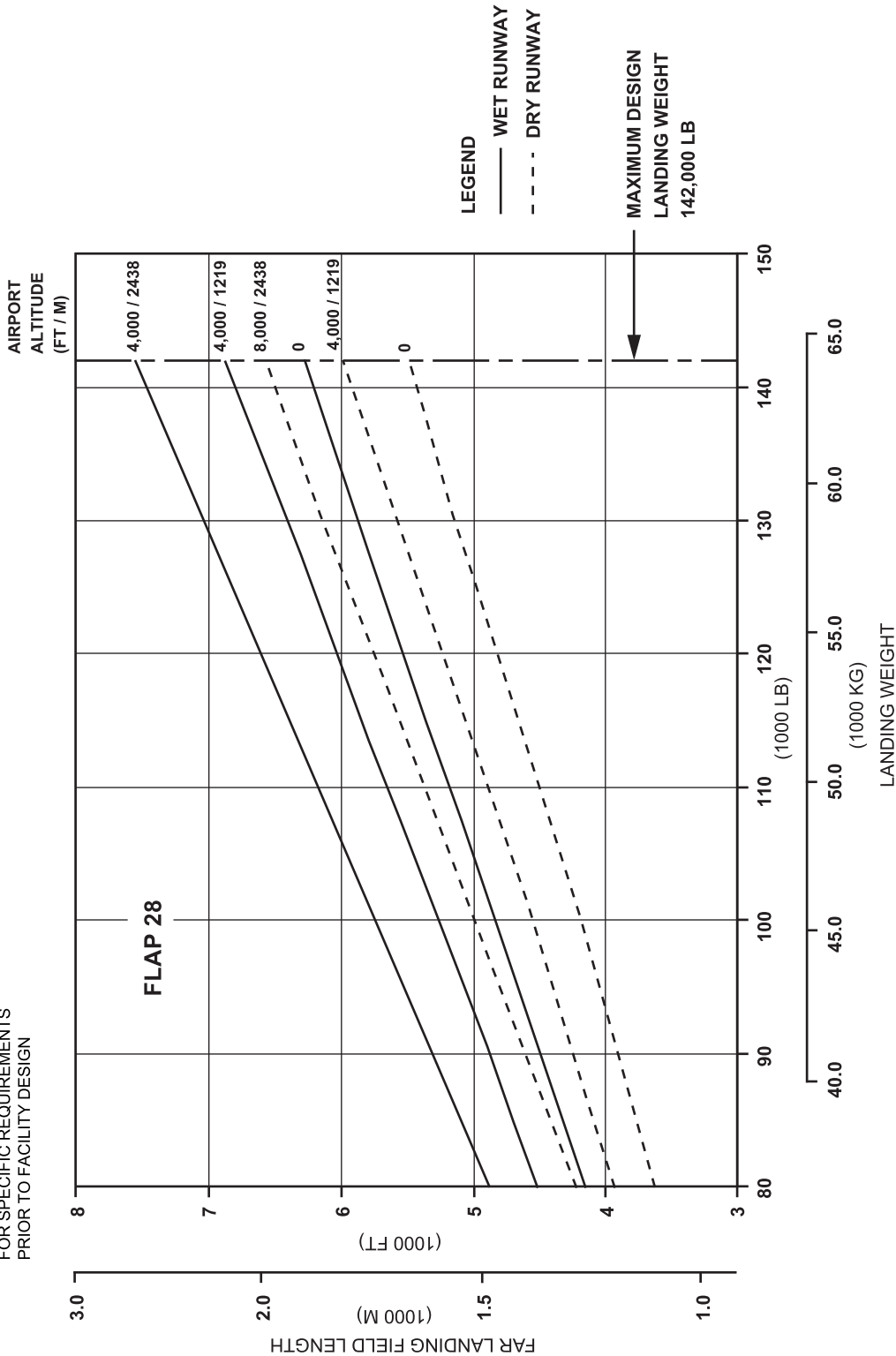

3.4 FAR LANDING RUNWAY LENGTH REQUIREMENTS
3.4.1 FLAP 28
MODEL MD-90-30/-30ER



$V_{app} = 1.3V_s$ FAR
 = (DRY AND WET RUNWAY)
 V_{app} IS APPROACH VELOCITY
 V_s IS APPROACH VELOCITY

**NOT TO BE USED FOR
 FLIGHT PLANNING PURPOSES**

- NOTES:
- STANDARD DAY
 - 3-DEGREE GLIDESLOPE
 - SLATS EXTENDED
 - ZERO WIND AT 50 FT HEIGHT
 - ZERO RUNWAY GRADIENT
 - COORDINATE WITH USING AIRLINE FOR SPECIFIC REQUIREMENTS PRIOR TO FACILITY DESIGN

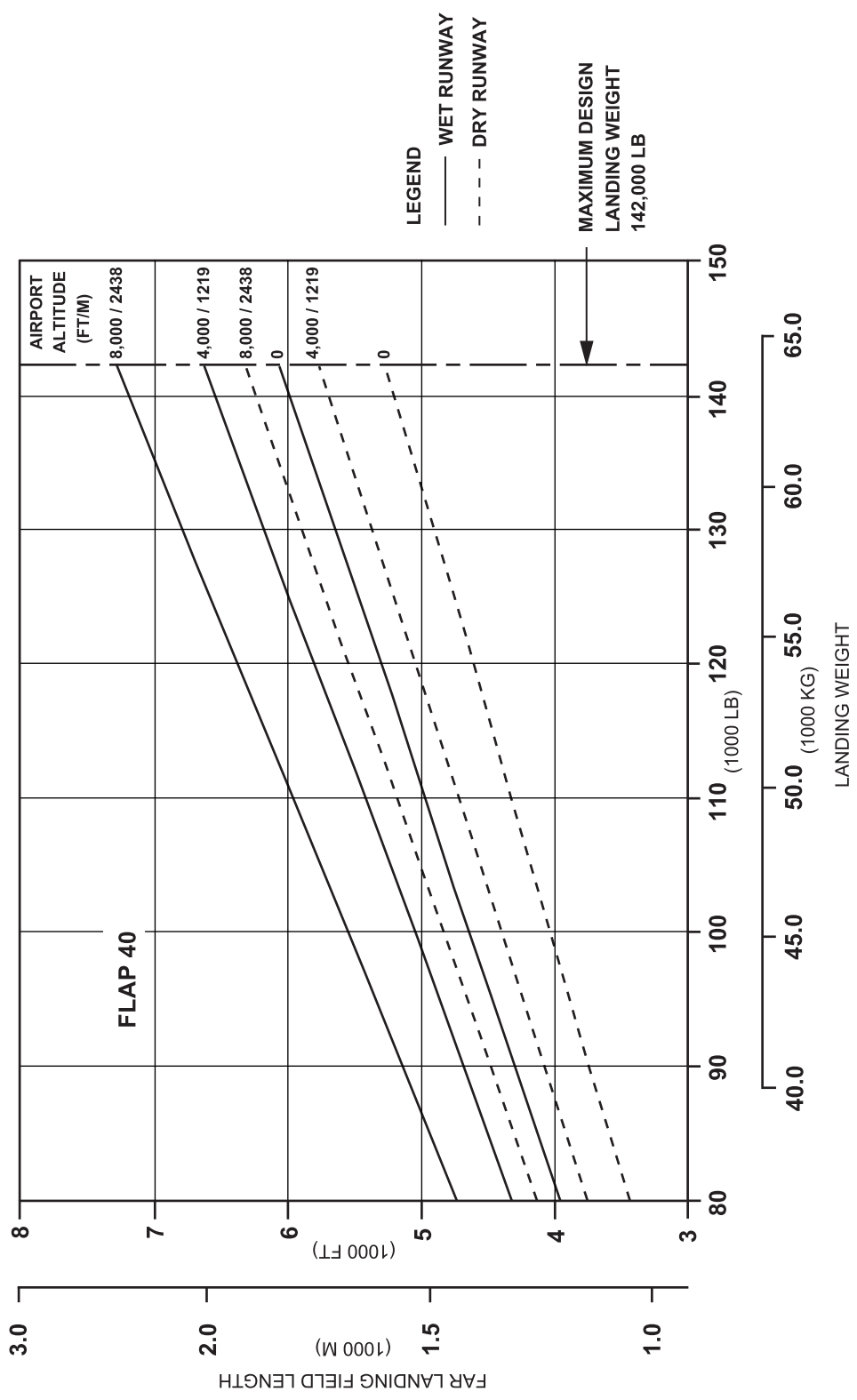

3.4 FAR LANDING RUNWAY LENGTH REQUIREMENTS
3.4.2 FLAP 40
MODEL MD-90-30/-30ER



This page intentionally left blank



4.0 GROUND MANEUVERING

4.1 General Information

4.2 Turning Radii, No Slip Angle

4.3 Minimum Turning Radii

4.4 Visibility from Cockpit

4.5 Runway and Taxiway Turn Paths

4.6 Runway Holding Bay (Apron)



This page intentionally left blank



4.0 GROUND MANEUVERING

4.1 General Information

This section provides airplane turning capability and maneuvering characteristics.

For ease of presentation, these data have been determined from the theoretical limits imposed by the geometry of the aircraft, and where noted, provide for a normal allowance for tire slippage. As such, they reflect the turning capability of the aircraft in favorable operating circumstances. The data should only be used as guidelines for determining such parameters and to obtain the maneuvering characteristics of this aircraft type.

In the ground operating mode, varying airline practices may demand that more conservative turning procedures be adopted. Airline operating techniques will vary in level of performance over a wide range of circumstances throughout the world. Variations from standard aircraft operating patterns may be necessary to satisfy physical constraints within the maneuvering area, such as adverse grades, limited space, or high risk of jet blast damage. For these reasons, ground maneuvering requirements should be coordinated with the using airlines prior to layout planning.

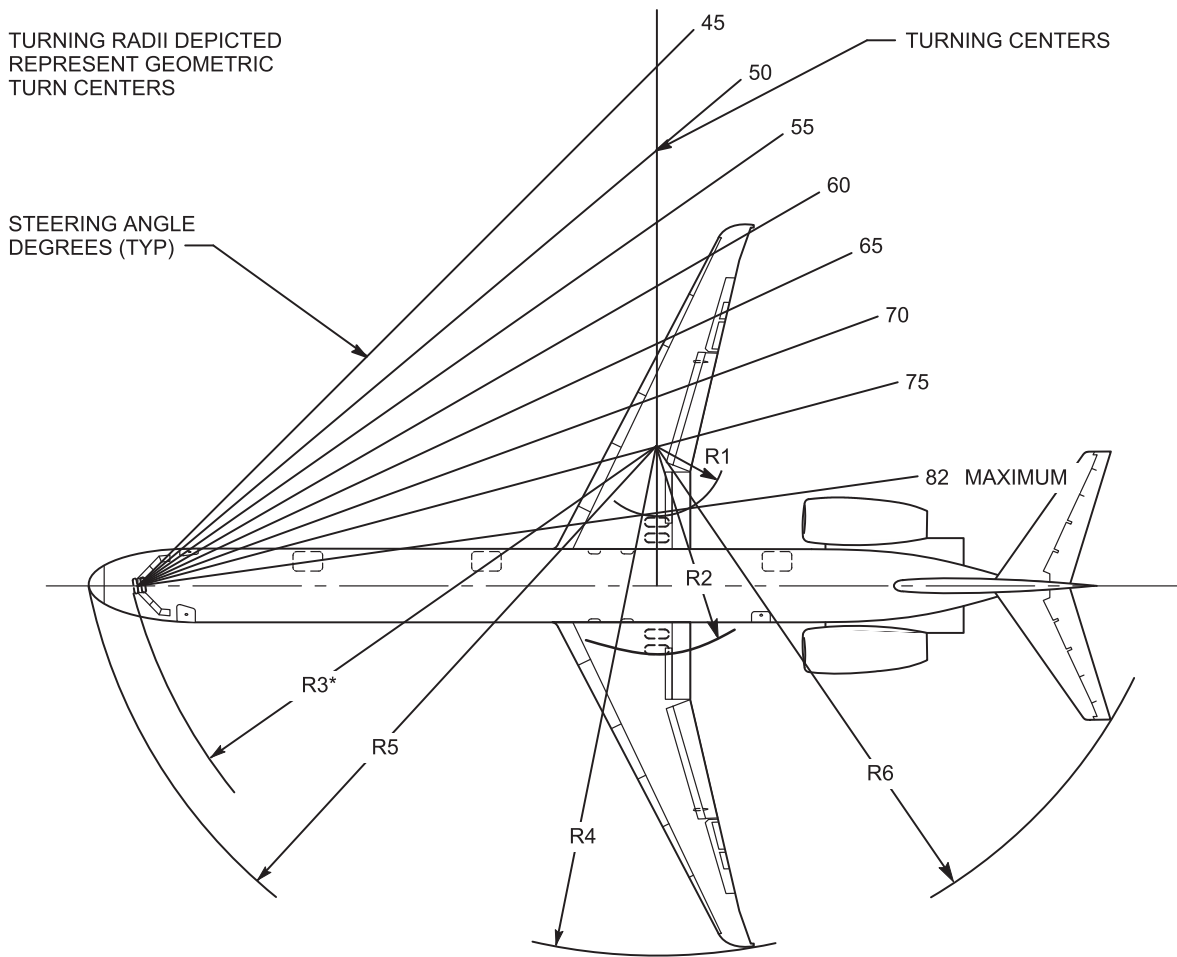

NOTE: ACTUAL OPERATING DATA MAY BE GREATER THAN VALUES SHOWN SINCE TIRE SLIPPAGE IS NOT CONSIDERED IN THESE CALCULATIONS. CONSULT AIRLINE FOR OPERATING PROCEDURES.

*R3 IS MEASURED TO OUTSIDE FACE OF TIRE.

STEERING ANGLE (DEG)	R1		R2		R3*		R4		R5		R6	
	FT	M	FT	M	FT	M	FT	M	FT	M	FT	M
30	123.5	37.6	143.9	43.8	155.2	47.3	188.2	57.4	158.3	48.2	168.0	51.2
45	67.0	20.4	87.4	26.6	110.0	33.5	132.0	40.2	114.6	34.9	118.6	36.1
50	54.6	16.6	75.0	22.8	101.6	31.0	119.6	36.5	106.7	32.5	108.6	33.1
55	43.8	13.4	64.2	19.6	95.1	29.0	109.0	33.2	100.5	30.6	100.5	30.6
60	34.4	10.5	54.8	16.7	90.0	27.4	99.6	30.4	95.8	29.2	93.7	28.6
65	25.8	7.9	46.2	14.1	86.0	26.2	91.2	27.8	92.1	28.1	88.0	26.8
70	17.9	5.5	38.3	11.7	83.0	25.3	83.4	25.4	89.3	27.2	83.2	25.4
75	10.5	3.2	30.9	9.4	80.7	24.6	76.1	23.2	87.2	26.6	79.1	24.1
82 MAXIMUM	0.6	0.2	21.0	6.4	78.8	24.0	66.5	20.3	85.5	26.0	74.6	22.7

4.2 TURNING RADII, NO SLIP ANGLE MODEL MD-90-30/-30ER

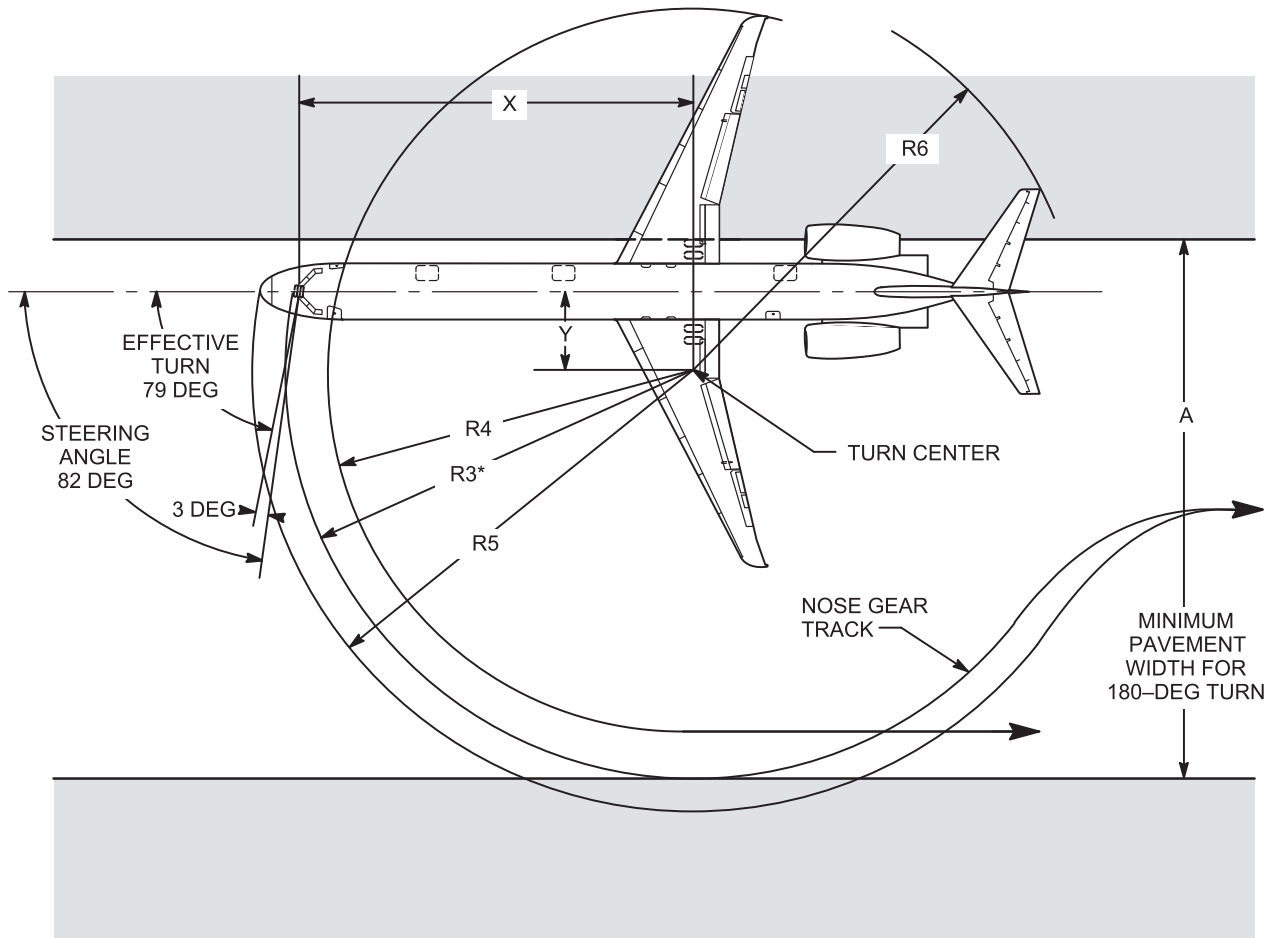

NOTES:

- 3-DEG TIRE SLIP ANGLE APPROXIMATE FOR 82-DEG NOSE WHEEL DEFLECTION DURING VERY SLOW TURNING
- CONSULT AIRLINE FOR ACTUAL OPERATING DATA
- NO DIFFERENTIAL BRAKING OR UNSYMMETRICAL THRUST
- *R3 IS MEASURED TO OUTSIDE FACE OF TIRE

EFFECTIVE TURN ANGLE	X		Y		A		R3*		R4		R5		R6	
	FT	M	FT	M	FT	M	FT	M	FT	M	FT	M	FT	M
79 DEG	77.2	23.5	15.0	4.6	104.7	31.9	79.5	24.2	70.5	21.5	86.1	26.2	76.4	23.3

4.3 MINIMUM TURNING RADII MODEL MD-90-30/-30ER

**NOT TO BE USED FOR
LANDING APPROACH VISIBILITY**

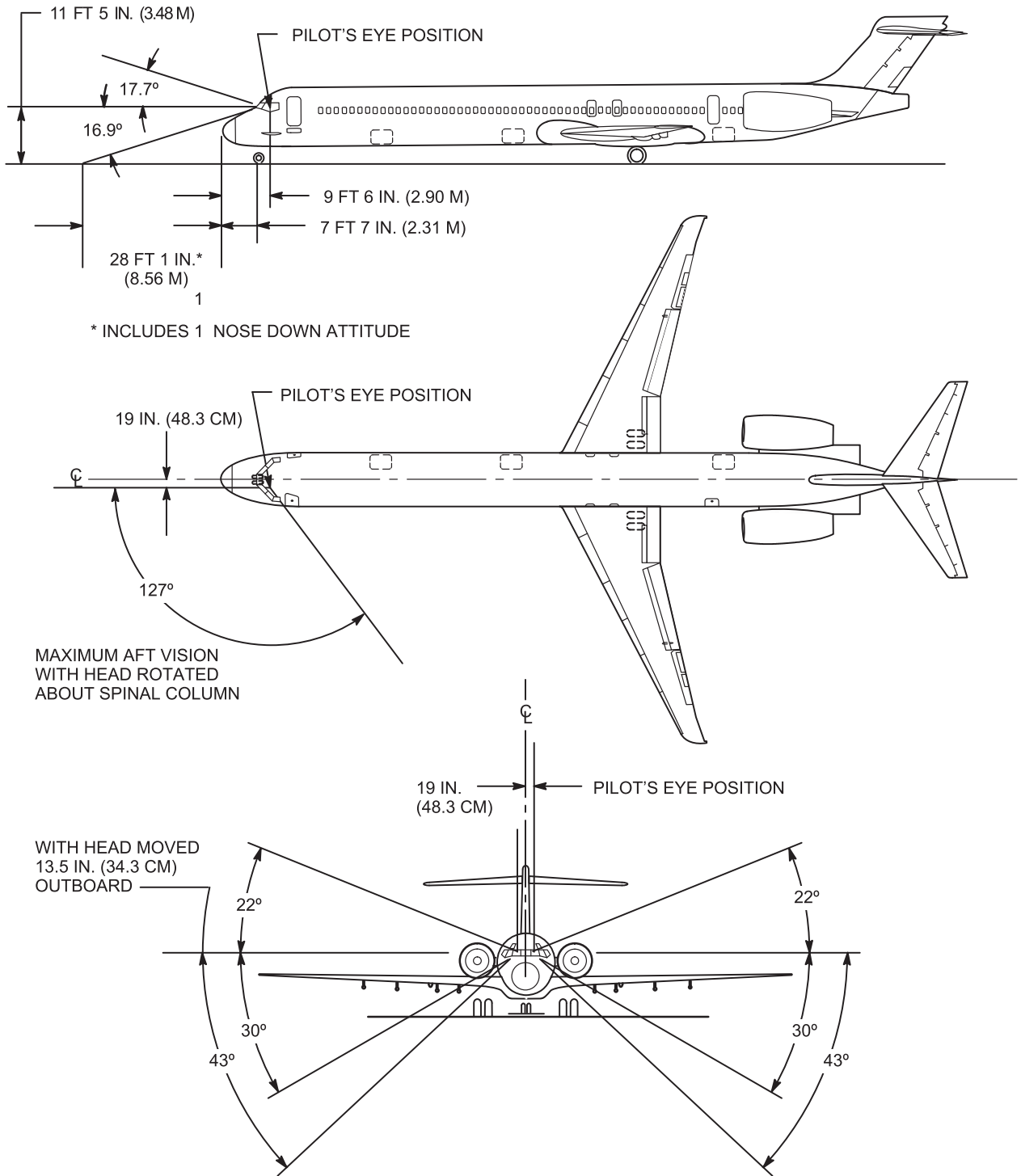

**4.4 VISIBILITY FROM COCKPIT IN STATIC POSITION
MODEL MD-90-30/-30ER**

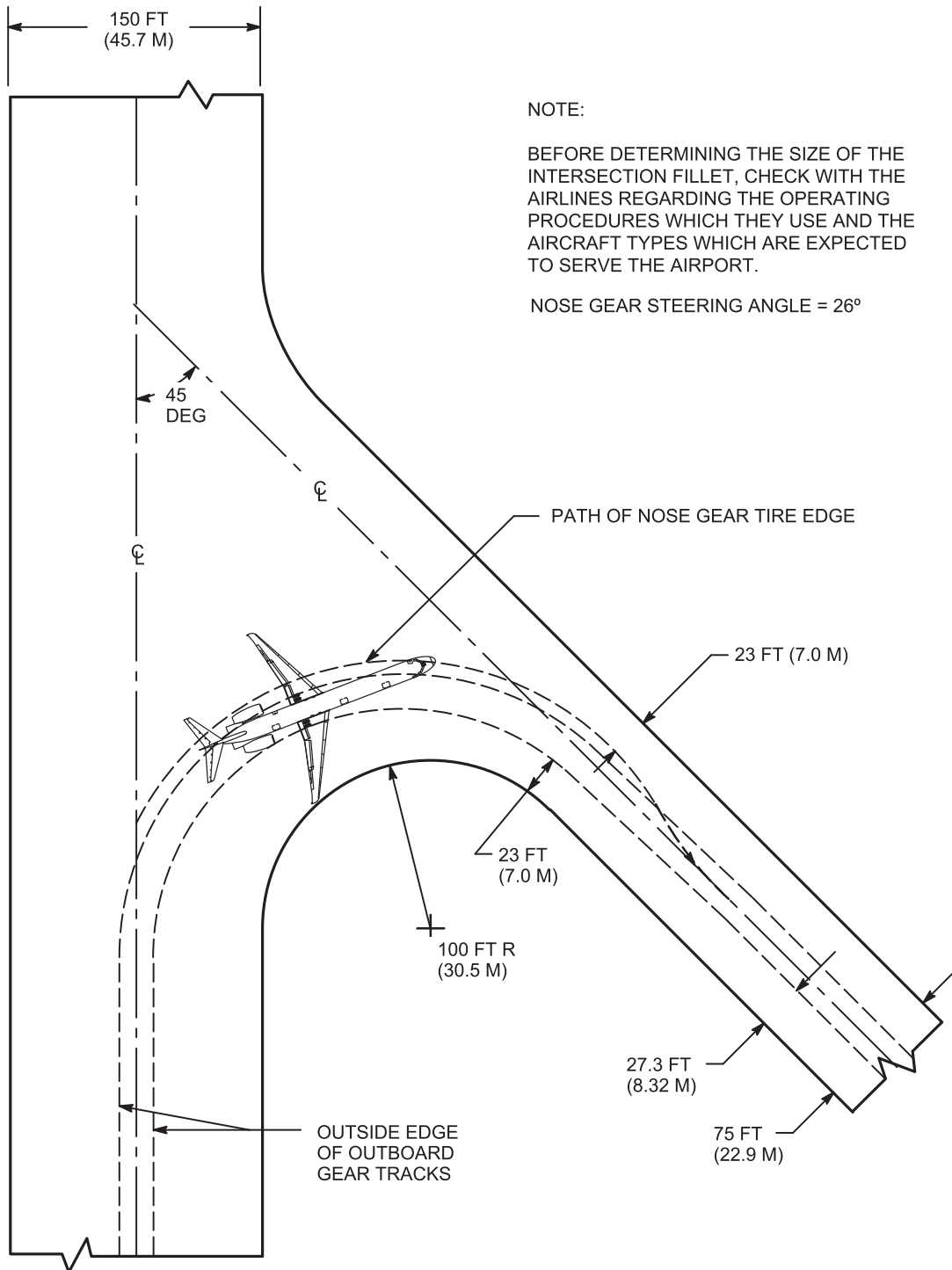

4.5 RUNWAY AND TAXIWAY TURN PATHS
4.5.1 MORE THAN 90-DEG TURN -- RUNWAY TO TAXIWAY
MANEUVERING METHOD -- JUDGMENT OVERSTEERING
MODEL MD-90-30/-30ER

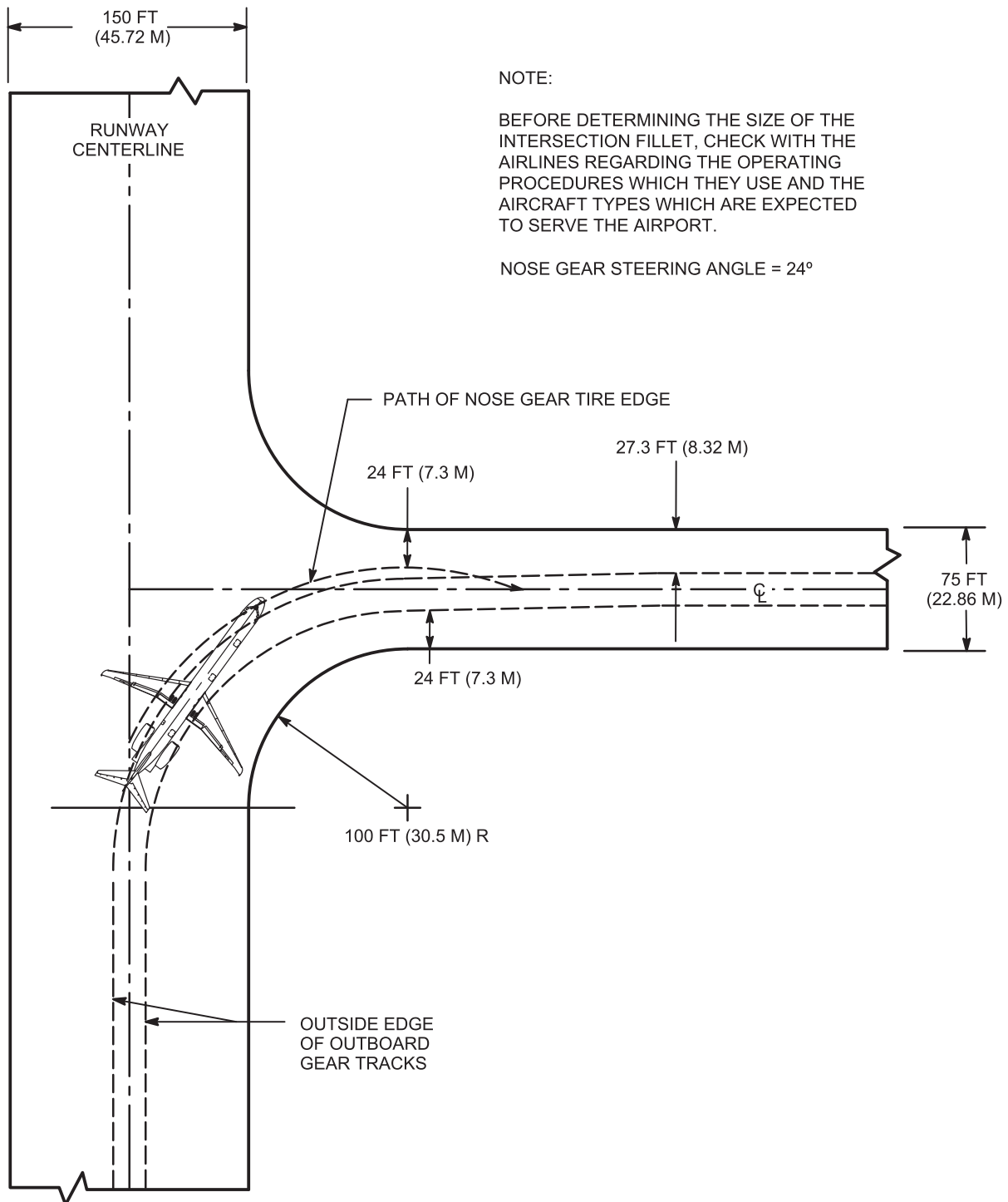

4.5 RUNWAY AND TAXIWAY TURN PATHS
4.5.2 90-DEGREE TURN -- RUNWAY TO TAXIWAY
MANEUVERING METHOD -- JUDGMENTAL OVERSTEERING
MODEL MD-90-30/-30ER

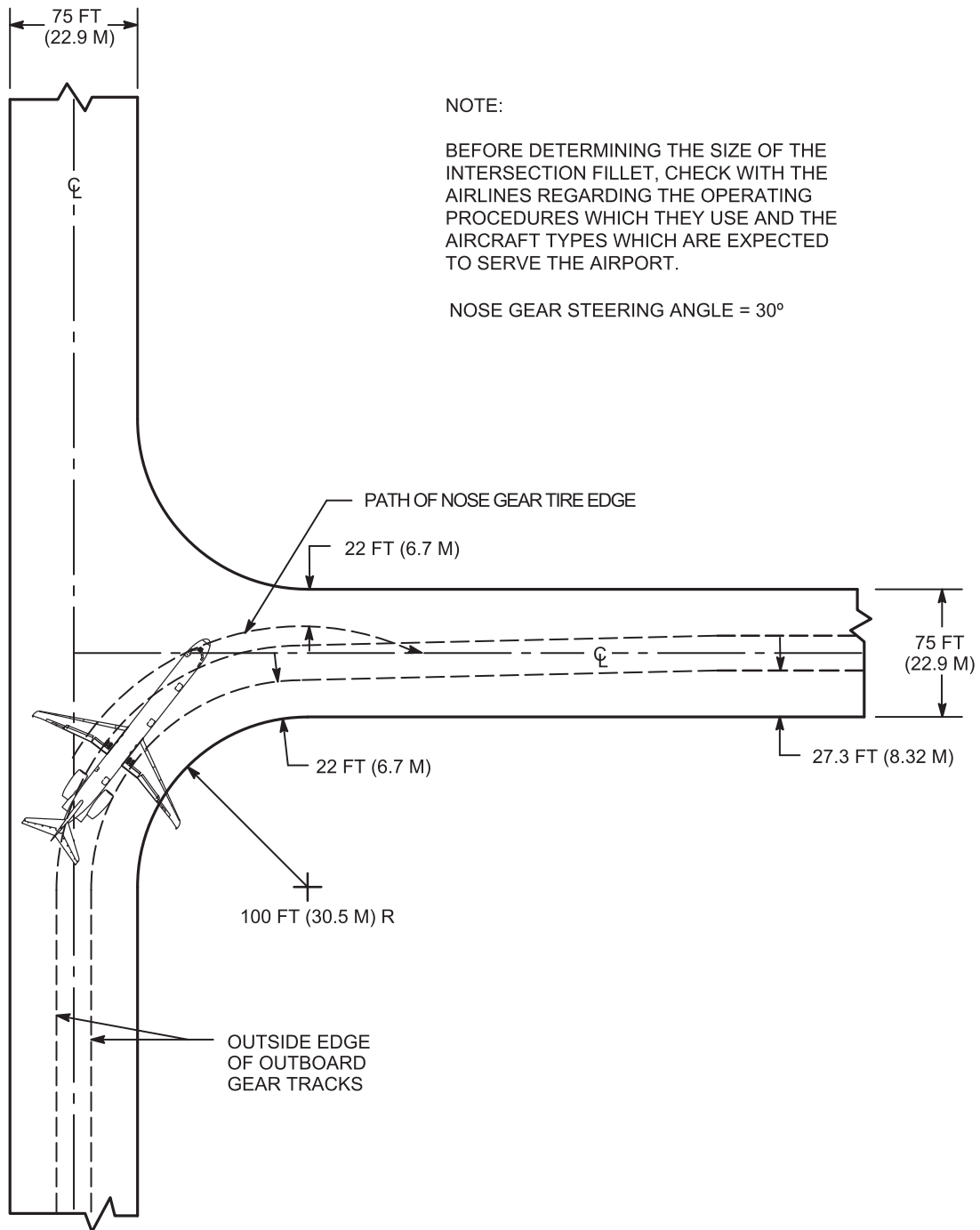

4.5 RUNWAY AND TAXIWAY TURN PATHS
4.5.3 90-DEGREE TURN TAXIWAY TO TAXIWAY
MANEUVERING METHOD -- JUDGMENTAL OVERSTEERING
MODEL MD-90-30/-30ER

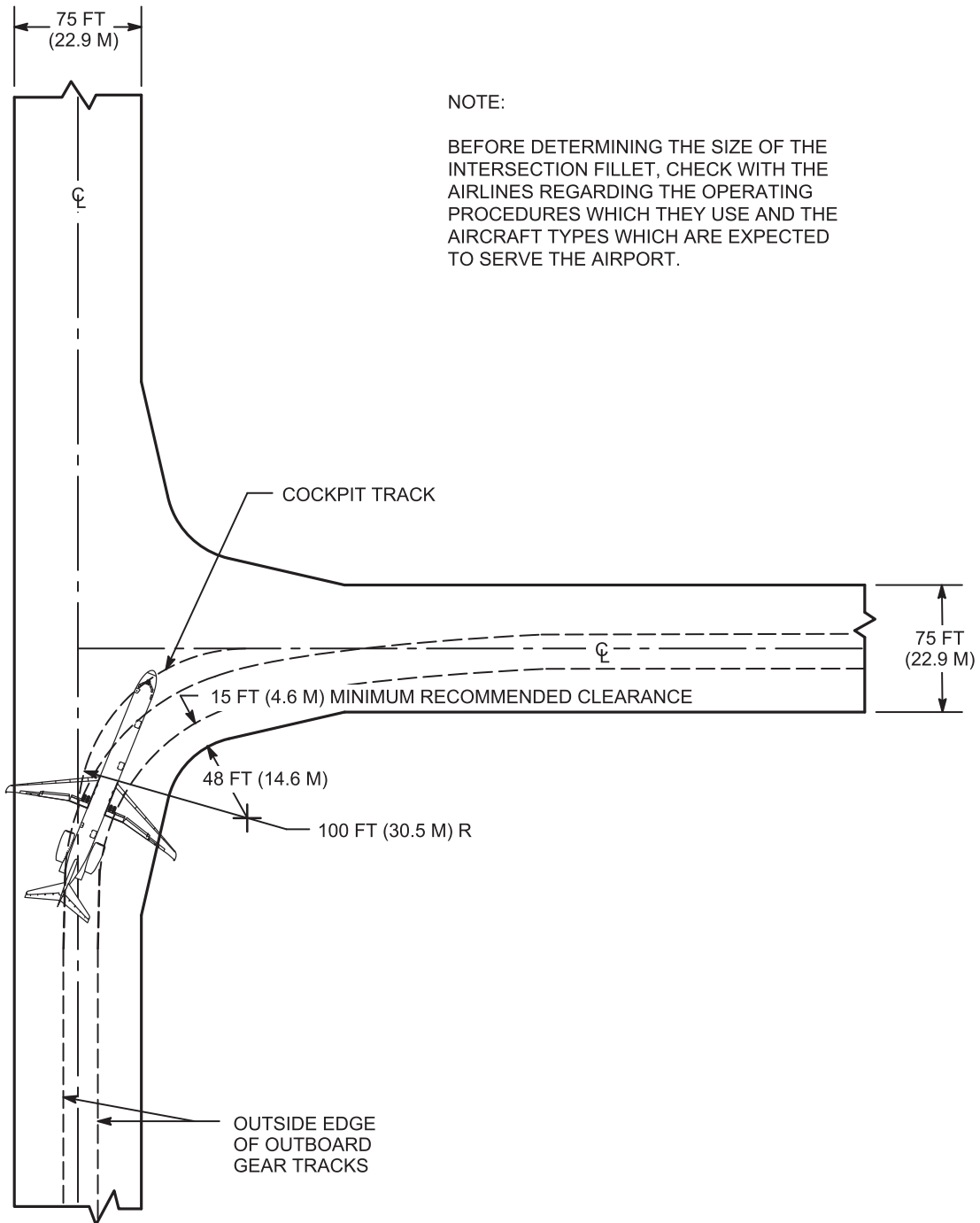

NOTE:

BEFORE DETERMINING THE SIZE OF THE INTERSECTION FILLET, CHECK WITH THE AIRLINES REGARDING THE OPERATING PROCEDURES WHICH THEY USE AND THE AIRCRAFT TYPES WHICH ARE EXPECTED TO SERVE THE AIRPORT.

4.5 RUNWAY AND TAXIWAY TURN PATHS
4.5.4 90-DEGREE TURN -- TAXIWAY TO TAXIWAY
MANEUVERING METHOD -- COCKPIT OVER CENTERLINE STEERING
MODEL MD-90-30/-30ER

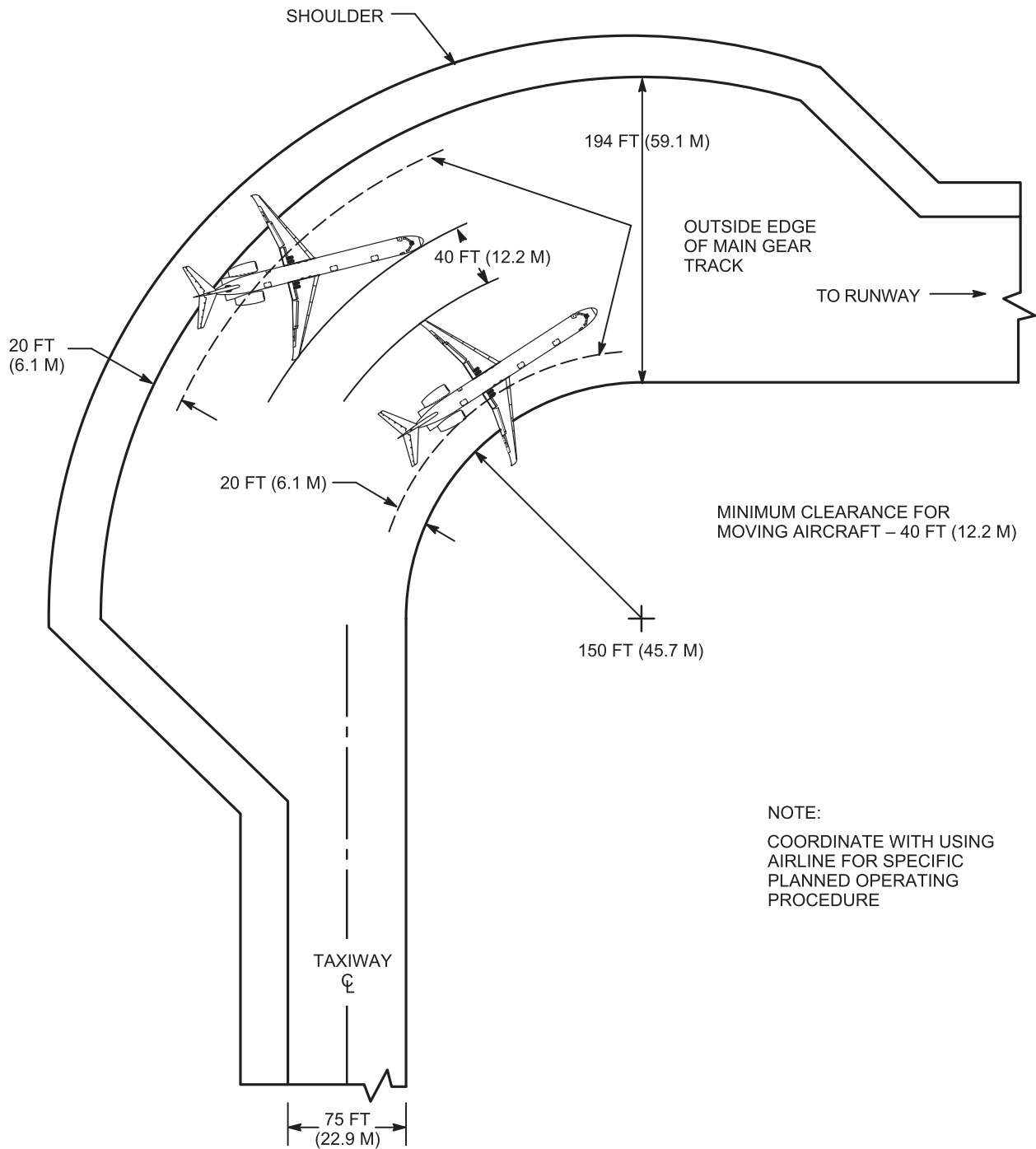

**4.6 RUNWAY HOLDING BAY (APRON)
MODEL MD-90-30/-30ER**



This page intentionally left blank



5.0 TERMINAL SERVICING

5.1 Airplane Servicing Arrangement (Typical)

5.2 Terminal Operations, Turnaround Station

5.3 Terminal Operations, En Route Station

5.4 Ground Service Connections

5.5 Engine Starting Pneumatic Requirements

5.6 Ground Pneumatic Power Requirements

5.7 Preconditioned Airflow Requirements

5.8 Ground Towing Requirements



This page intentionally left blank

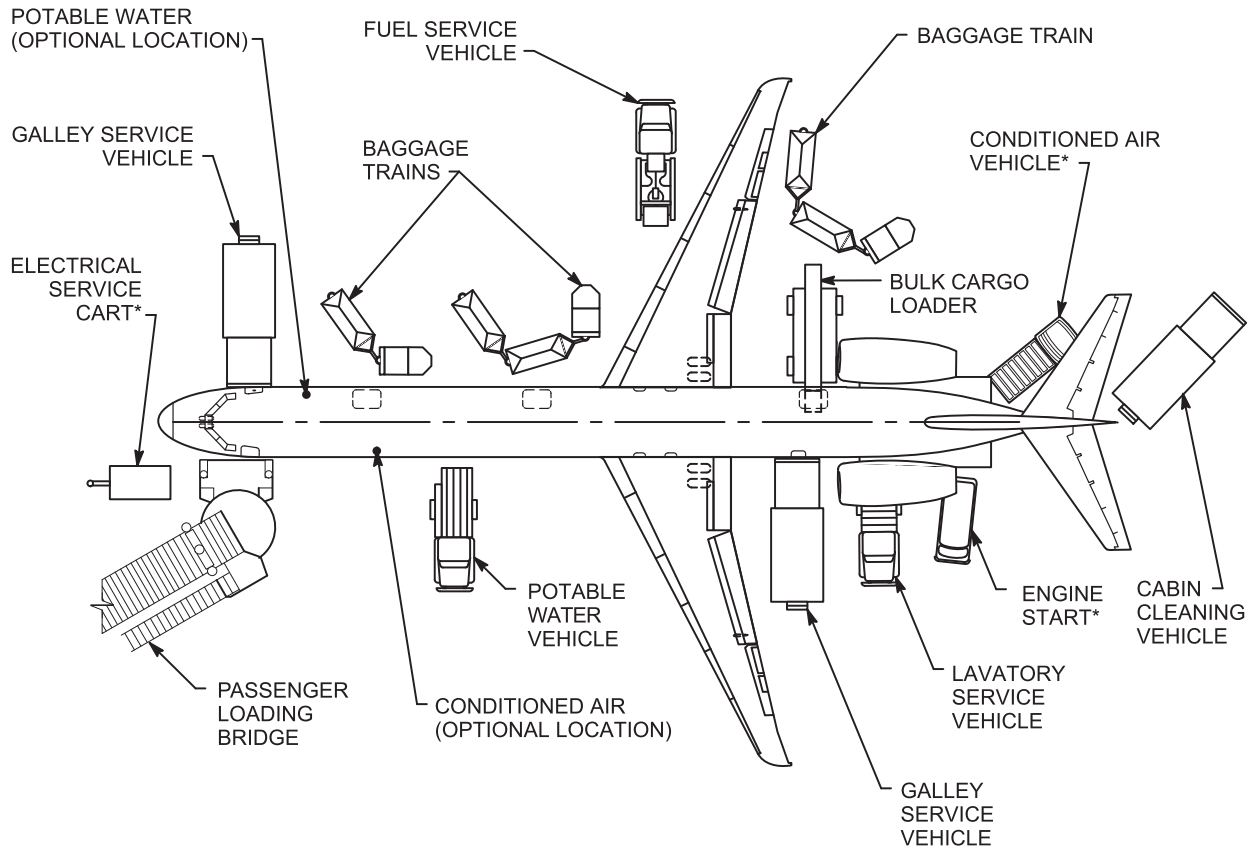

* AUXILIARY POWER UNIT OR FIXED FACILITIES CAN ALSO PROVIDE:

1. ELECTRICAL POWER
2. ENGINE START
3. AIR-CONDITIONING

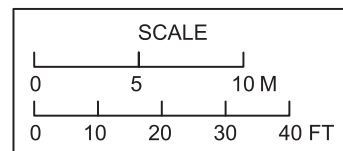

5.0 TERMINAL SERVICING

5.1 AIRPLANE SERVICING ARRANGEMENT (TYPICAL) MODEL MD-90-30/-30ER

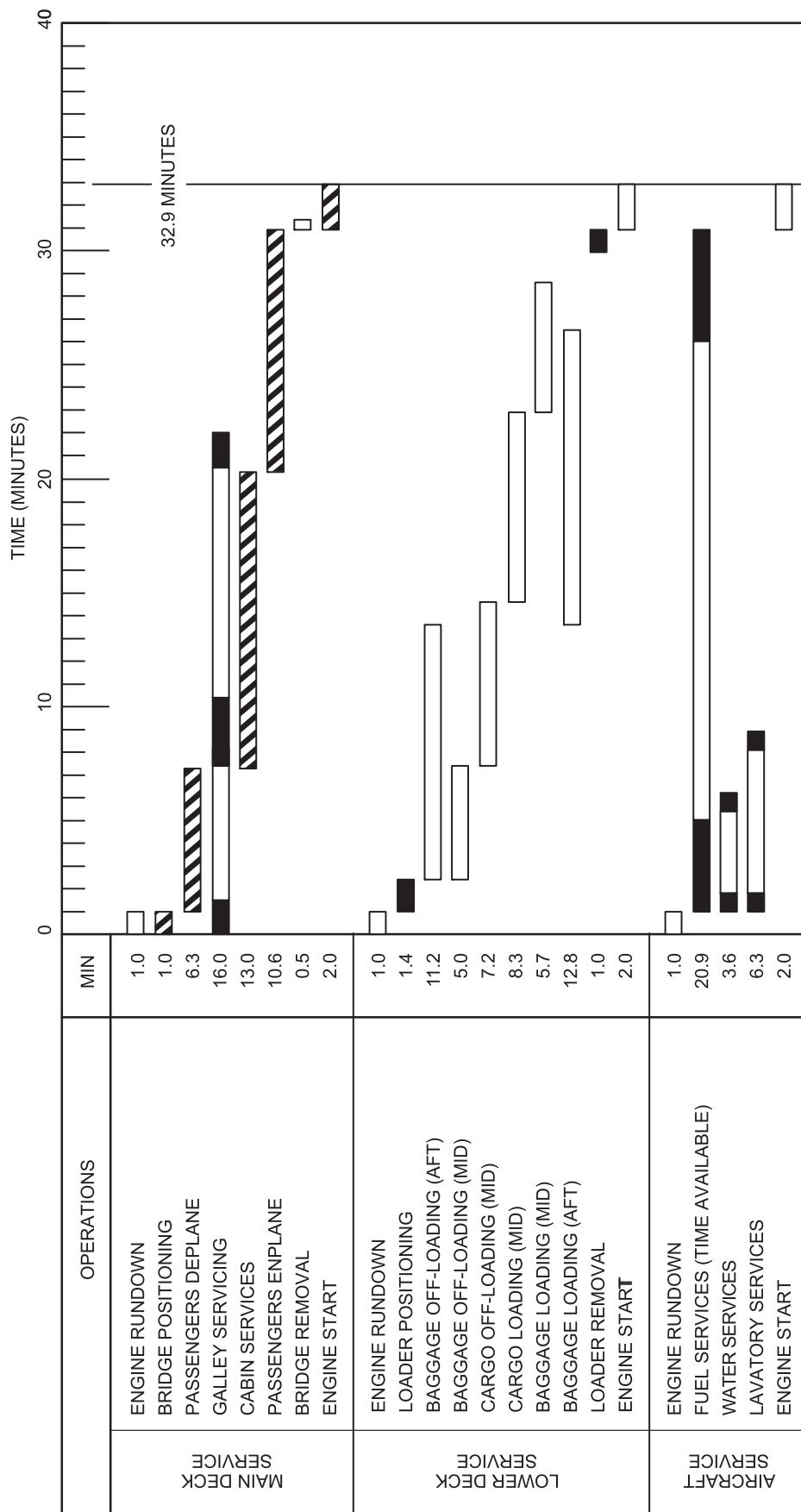

- 1. [Hatched Box] INDICATES CRITICAL TIMEPATH
- 2. [Solid Black Box] INDICATES VEHICLE POSITIONING/REMOVAL
- 3. 100-PERCENT LOAD FACTOR/100-PERCENT EXCHANGE
- 4. SINGLE BRIDGE
- 5. BULK BAGGAGE/CARGO SYSTEM
- 6. 1.2 CHECKED BAGS PER PASSENGER
- 7. 1,500 POUNDS OF CARGO
- 8. FULL CABIN CLEANING WITH A CREW OF FOUR

5.2 TERMINAL OPERATIONS, TURNAROUND STATION MODEL MD-90-30/-30ER

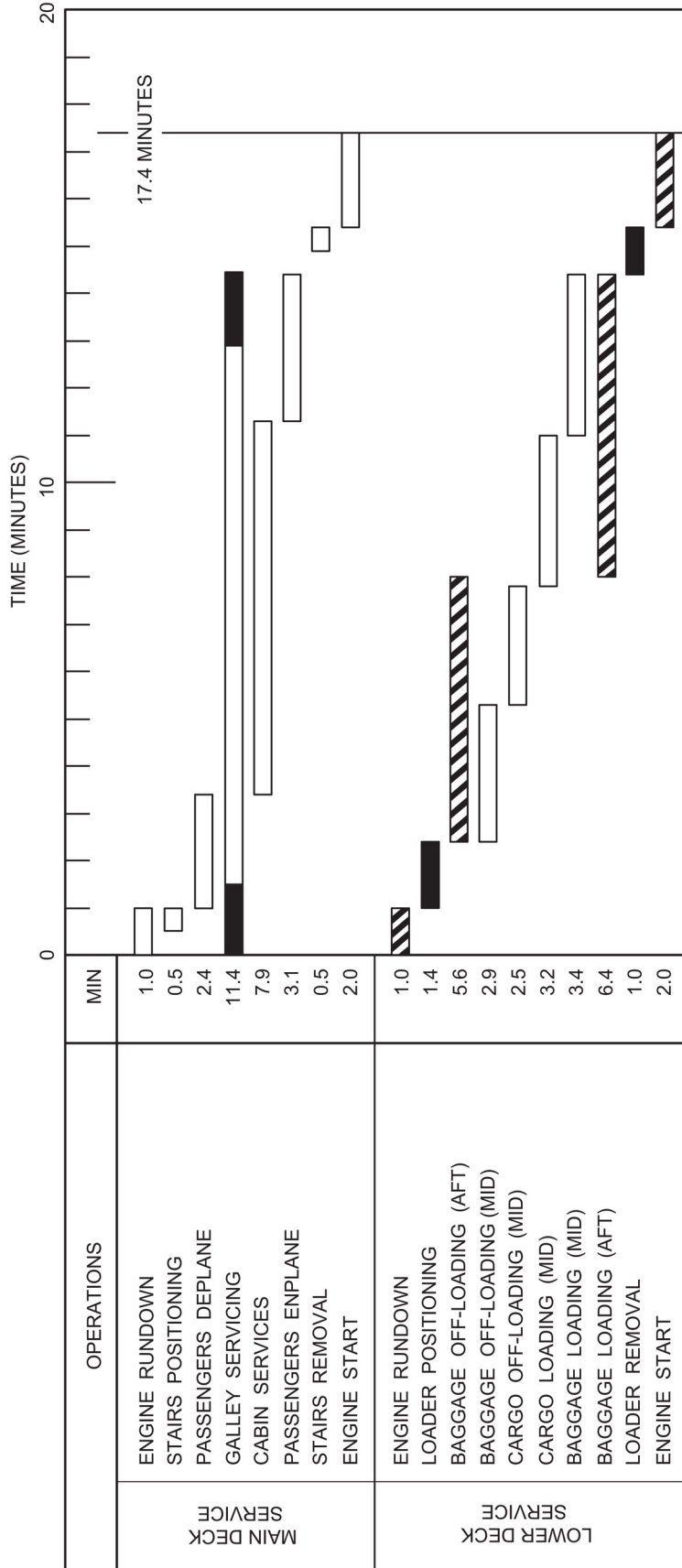

- 1. ■ INDICATES CRITICAL TIMEPATH
- 2. ■ INDICATES VEHICLE POSITIONING/REMOVAL
- 3. ■ 100-PERCENT LOAD FACTOR/55-PERCENT EXCHANGE
- 4. ■ VENTRAL AND AIRSTAIR
- 5. ■ BULK BAGGAGE/CARGO SYSTEM
- 6. ■ GALLEY/CABIN SERVICE AND CARGO HANDLING (500 LB) ARE BASED ON TIME AVAILABLE

5.3 TERMINAL OPERATIONS, ENROUTE STATION MODEL MD-90-30/-30ER

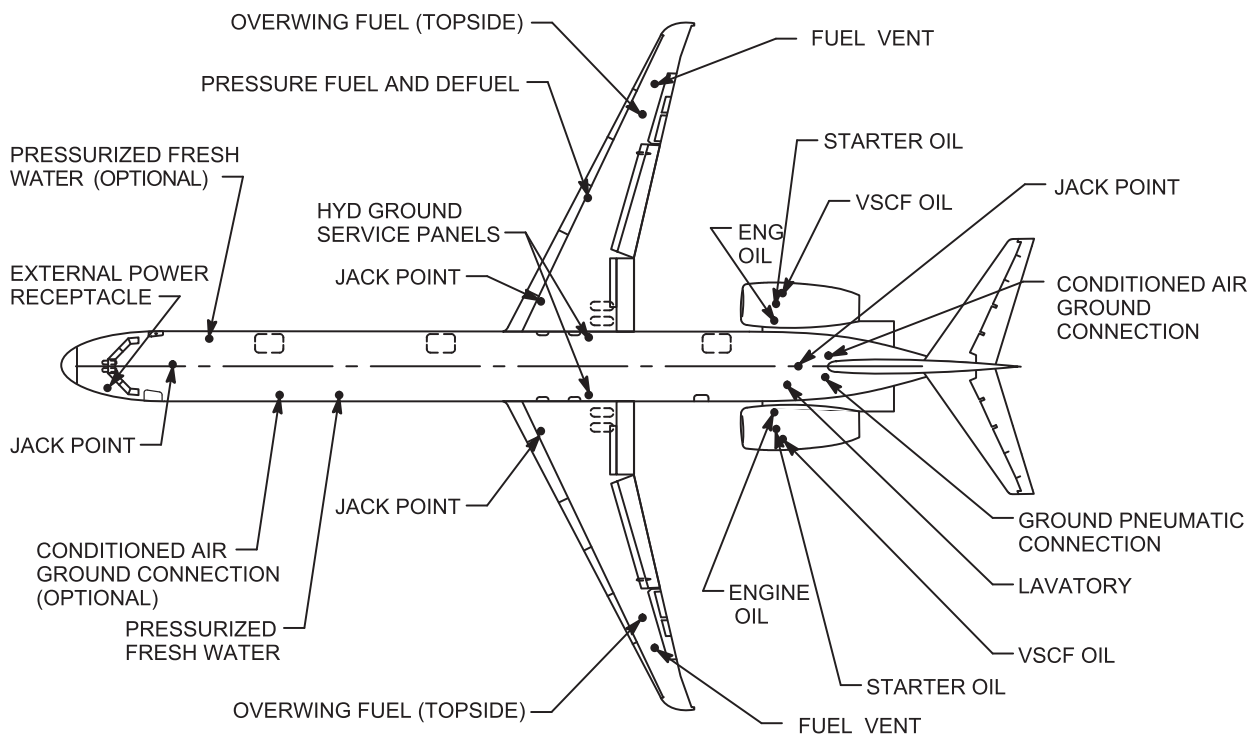

TOP VIEW

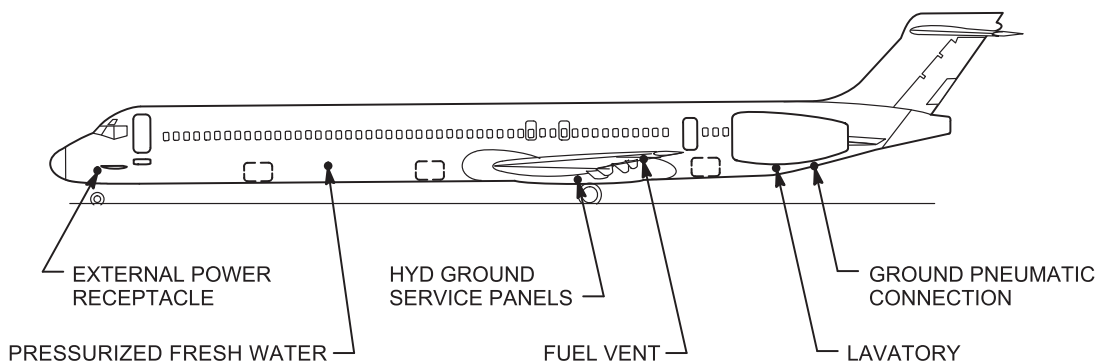

SIDE VIEW

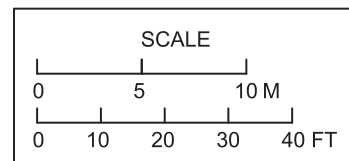

5.4 GROUND SERVICE CONNECTIONS MODEL MD-90-30/-30ER



	DISTANCE AFT OF NOSE	DISTANCE FROM AIRPLANE CENTERLINE				HEIGHT ABOVE GROUND				
		RIGHT SIDE		LEFT SIDE		MINIMUM		MAXIMUM		
		FT-IN.	METERS	FT-IN.	METERS	FT-IN.	METERS	FT-IN.	METERS	
5.4.1 HYDRAULIC SYSTEM <ul style="list-style-type: none"> ● 2 SERVICE PANELS, LH AND RH HYDRAULIC GROUND CONNECTIONS ● 6 ACCUMULATORS <ul style="list-style-type: none"> A. 2 BRAKE ACCUMULATORS, LH AND RH B. 2 THRUST REVERSER ACCUMULATORS, LH AND RH C. 1 ELEVATOR ACCUMULATOR, LH D. 1 COMBINATION ELEVATOR, RUDDER, AND VENTRAL STAIR ACCUMULATOR, RH (SYSTEM PRESSURE 3000 PSI SKYDROL 500B)	82-10	25.2	4-7	1.4	4-7	1.4	4-2	1.3	4-6	1.4
	83-0	25.3	4-7	1.4	4-7	1.4	6-6	2.0	6-10	2.1
	119-11	36.6	-	-	4-6	1.4	10-9	3.3	11-3	3.4
	120-4	36.7	3-10	1.2	-	-	8-8	2.6	9-2	2.6
	118-0	36.0	-	-	4-2	1.3	8-11	2.6	9-2	2.6
	121-11	37.2	3-10	1.2	-	-	9-3	2.8	9-10	3.0
5.4.2 ELECTRICAL SYSTEM <ul style="list-style-type: none"> ● 1 GROUND SERVICE CONNECTION 115/200 VOLTS, 400 HZ, 3-PHASE, 4-WIRE 90-KVA CONT. AT 0.80 TO 1.0 P.F. 	7-5	2.3	-	-	3-4	1.0	4-11	1.5	5-7	1.7
5.4.3 OXYGEN SYSTEM <ul style="list-style-type: none"> ● NO GROUND SERVICE CONNECTION A. AIR CREW SYSTEM, ONE 76 FT³ CYLINDER B. PASSENGER SYSTEM, MODULAR SYSTEM 	O ₂ CYLINDER EXCHANGED. LOCATED IN AIR CREW COMPARTMENT. O ₂ UNITS EXCHANGED. LOCATED IN ENV. PANEL UNDER THE OVERHEAD LUG. RACK OF EACH ROW, LAVATORIES, AND CABIN ATTENDANT STATIONS.									
5.4.4 FUEL SYSTEM <ul style="list-style-type: none"> ● 1 GROUND SERVICE CONNECTION 420 GPM (1590 LPM) AT 50 PSIG (RH WING) ● 3 FUEL TANKS <ul style="list-style-type: none"> 2 - OUTBOARD MAIN TANKS - 1383 GALLONS EACH (5234 LITERS) 1 - CENTER WING TANK - 3074 GALLONS (11,636 LITERS) 	82-7	25.2	26-5	8.1	-	-	6-10	2.1	7-2	2.2

5.4 GROUND SERVICE CONNECTIONS
5.4.1 CONNECTIONS AND CAPACITIES DATA
MODEL MD-90-30/-30ER



	DISTANCE AFT OF NOSE		DISTANCE FROM AIRPLANE CENTERLINE				HEIGHT ABOVE GROUND			
	FT-IN.	METERS	RIGHT SIDE		LEFT SIDE		MINIMUM		MAXIMUM	
			FT-IN.	METERS	FT-IN.	METERS	FT-IN.	METERS	FT-IN.	METERS
5.4.4 FUEL SYSTEM (CONT.) <ul style="list-style-type: none"> 1 - AUXILIARY TANK -- 565 GAL (2,138 LITERS) STANDARD ON -ER MODEL ONLY TOTAL CAPACITY WITH AUXILIARY TANK: 6405 U.S. GALLONS (24,242 LITERS) <ul style="list-style-type: none"> 2 GRAVITY FEED FILLER INLETS 4 SUMP DRAIN VALVES A. CENTER WING TANK (2 SUMPS) B. WING TANKS (1 SUMP EACH) 2 FUEL VENTS 	91-2	27.8	39-5	12.0	39-5	12.0	8-0	2.4	8-0	2.6
	78-5	23.9	2-4	0.7	2-4	0.7	3-7	1.1	3-11	1.2
	80-11	24.7	11-4	3.5	11-4	3.5	5-7	1.7	5-10	1.8
	93-2	28.4	44-2	13.5	44-2	13.5	7-5	2.3	7-10	2.4
5.4.5 PNEUMATIC SYSTEM <ul style="list-style-type: none"> 1 SERVICE CONNECTION FOR AIR CONDITIONING (SEE SECTION 5.6) AND ENGINE STARTING (SEE SECTION 5.5) 1 SERVICE CONNECTION FOR PRECONDITIONED AIR (SEE SECTION 5.7) OPTIONAL LOCATION 	119-10	36.5	-	-	1-9	0.5	6-7	2.0	7-2	2.2
	120-4	36.7	1-8	0.5	-	-	6-9	2.1	7-4	2.2
	34-3	10.4	-	-	4-6	1.4	6-0	1.8	6-7	2.0
5.4.6 POTABLE WATER SERVICE <ul style="list-style-type: none"> 1 SERVICE CONNECTION AT 10 PSIG PRESSURE 47 U.S. GALLONS (178 LITERS) AT 6 GALLONS (23 LITERS) PER MINUTE OPTIONAL LOCATION 	43-7	13.3	-	-	4-6	1.4	6-0	1.8	6-6	2.0
	23-2	7.1	4-4	1.3	-	-	5-9	1.8	6-4	1.9
5.4.7 LAVATORY SYSTEM <ul style="list-style-type: none"> 1 SERVICE CONNECTION ONE 47 U.S. GALLONS (178 LITERS) WASTE VOLUME PLUS 20 GALLONS (76 LITERS) FLUSH REQUIRED AT 25-50 PSIG AND 30 GALLONS (114 LITERS) PER MINUTE 	113-10	34.7	-	-	2-11	0.9	6-1	1.9	6-8	2.0

5.4 GROUND SERVICE CONNECTIONS
5.4.1 CONNECTIONS AND CAPACITIES DATA
MODEL MD-90-30/-30ER



	DISTANCE AFT OF NOSE		DISTANCE FROM AIRPLANE CENTERLINE				HEIGHT ABOVE GROUND			
	FT-IN.	METERS	RIGHT SIDE		LEFT SIDE		MINIMUM FT-IN.	MAXIMUM METERS		
			FT-IN.	METERS	FT-IN.	METERS				
5.4.8 ENGINE SERVICE SYSTEM <ul style="list-style-type: none"> ● 2 SERVICE POINTS <ul style="list-style-type: none"> A. OIL GRAVITY FILL-CAN SYSTEM OF 5.5 U.S. GALLONS (21 LITERS) OIL TYPE SPECIFIED BY IAE B. VSCF GENERATOR GRAVITY FEED-CAN, REFER TOMID-90 STANDARD PRACTICE MAINTENANCE MANUAL 	111-10	34.1	7-2	2.2	7-2	2.2	8-8	2.6	9-2	2.8
	113-2	34.5	11-5	3.5	11-5	3.5	8-3	2.5	8-9	2.7

5.4 GROUND SERVICE CONNECTIONS
5.4.1 CONNECTIONS AND CAPACITIES DATA
MODEL MD-90-30/-30ER



GROUND CONNECTION AIRFLOW

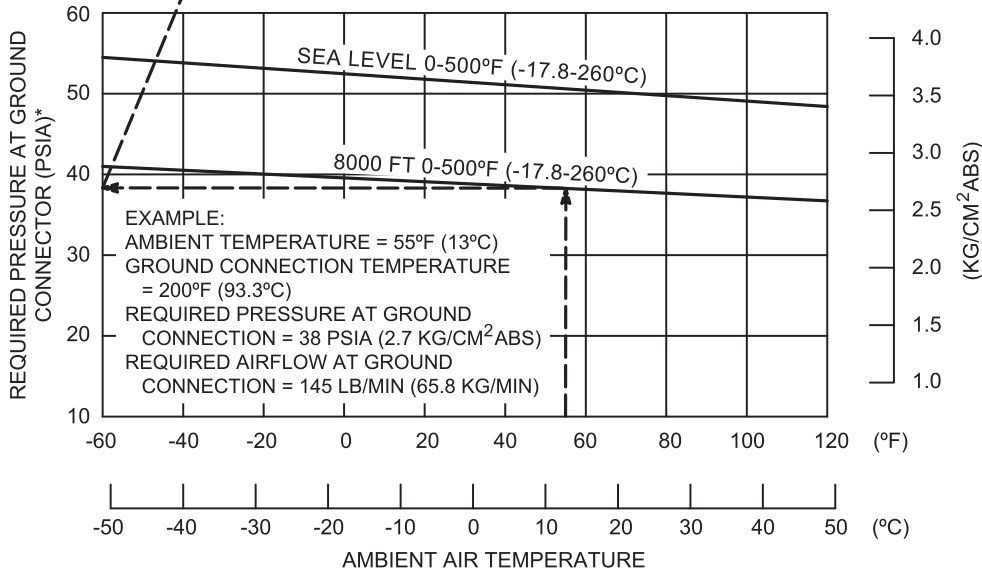
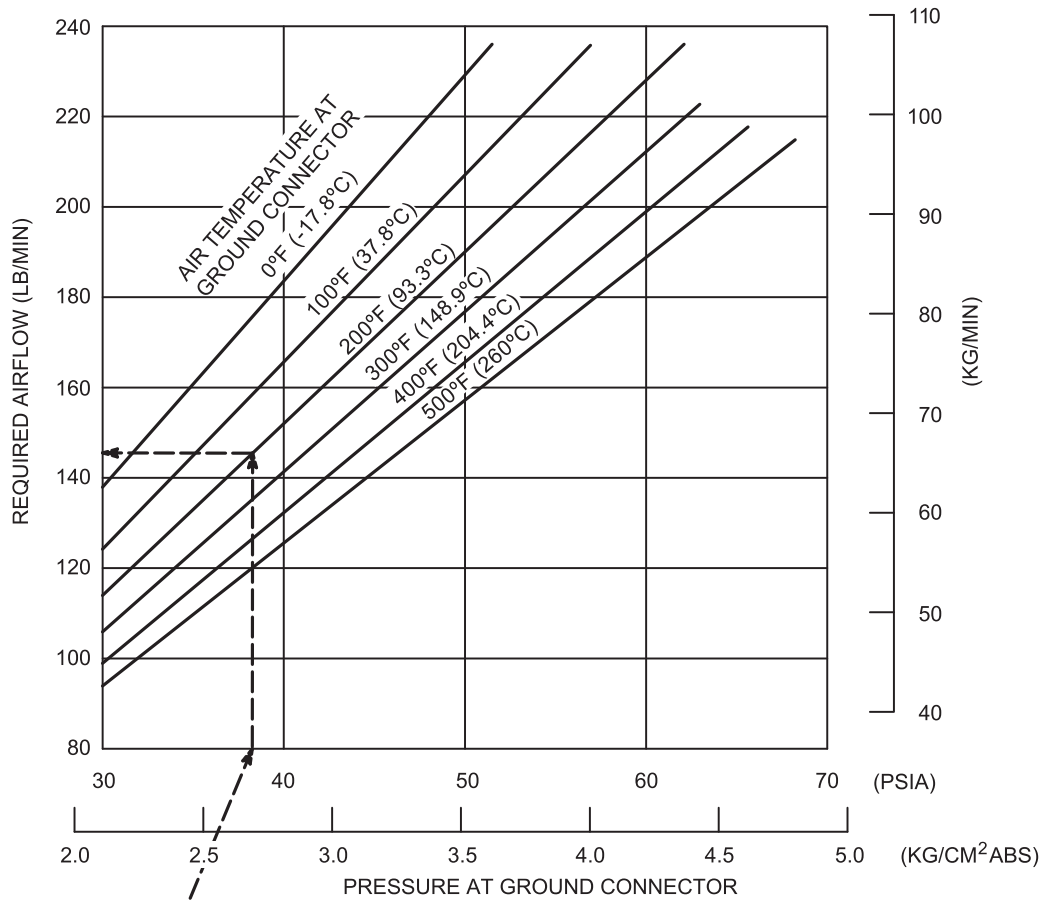

• THERE IS NO SATISFACTORY DEFINITION FOR "REQUIRED PRESSURE AT GROUND CONNECTOR" SO THAT A SINGLE LINE CAN BE DEPICTED. THE LINE DEPICTED IS FOR A 46-SECOND START TIME, WHICH IS AN ARBITRARY VALUE.

**5.5 ENGINE STARTING PNEUMATIC REQUIREMENTS
MODEL MD-90-30/-30ER**



INITIAL CABIN TEMP AT 0°F (-17.8°C). OUTSIDE AIR TEMP AT 0°F (-17.8°C). NO GALLEY LOAD, CLOUDY DAY, NO LIGHTS. P = 12 TO 70 PSIG AT THE GROUND CONNECTION. TEMP AT GROUND CONNECTION = 300°F (148.9°C)

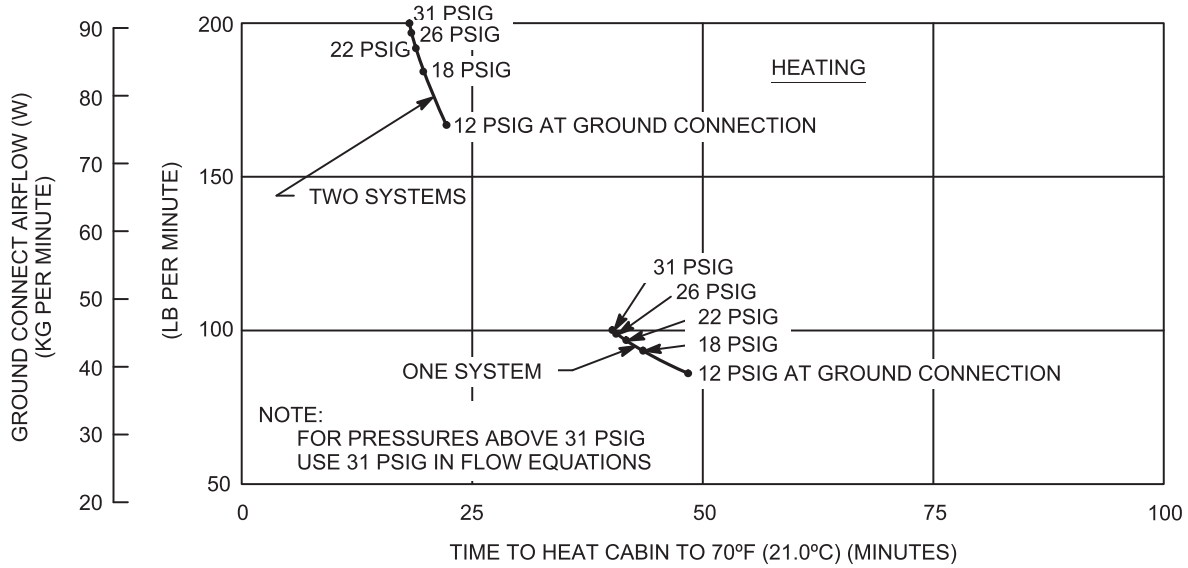

INITIAL CABIN TEMP AT 103°F (39.4°C). OUTSIDE AIR TEMP AT 103°F (39.4°C). SOLAR LOAD x 2620 BTU/HR. BRIGHT DAY; SOLAR IRRADIATION; NO GALLEY LOAD; DAY LIGHTING ON; NO PASSENGERS. P = 12 TO 70 PSIG AT THE GROUND CONNECTION. TEMP AT GROUND CONNECTION = 410°F (210°C)

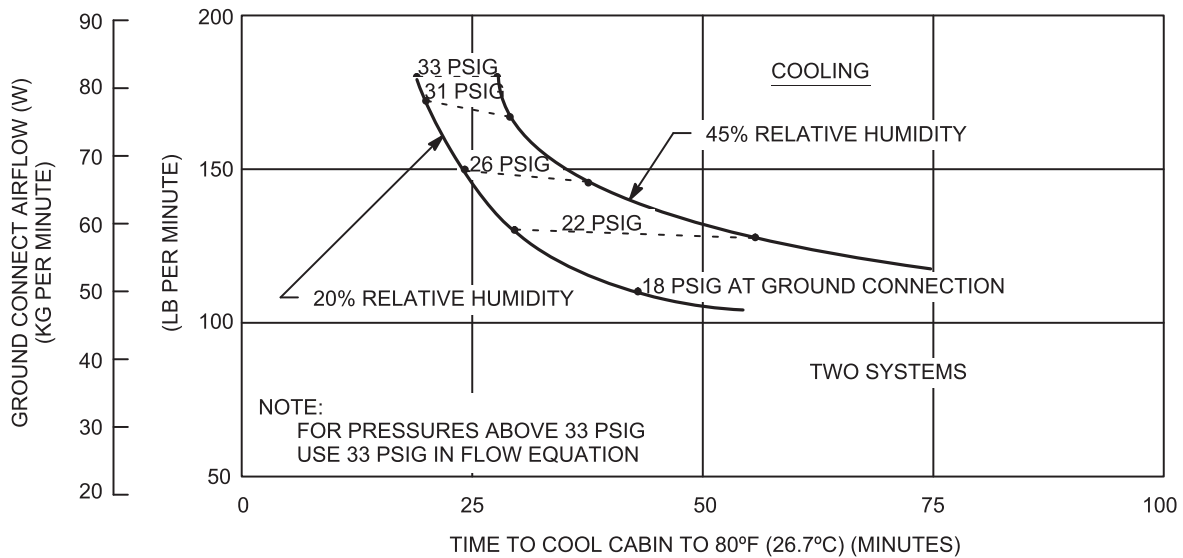

CAUTION: ELECTRICAL POWER IS REQUIRED WHENEVER THE AIR-CONDITIONING SYSTEM IS OPERATED

5.6 GROUND PNEUMATIC POWER REQUIREMENTS MODEL MD-90-30/-30ER



- ① – CABIN AT 75°F (24°C). 7 CREW, 172 PASSENGERS, NO GALLEY LOAD. BRIGHT DAY, SOLAR IRRADIATION, SOLAR LOAD x 2620 BTU/HR. DAY ELECTRICAL LOAD x 5150 BTU/HR.
- ② – CABIN AT 80°F (26.7°C). 7 CREW, 172 PASSENGERS, NO GALLEY LOAD. BRIGHT DAY, SOLAR IRRADIATION, SOLAR LOAD x 2620 BTU/HR. DAY ELECTRICAL LOAD x 5150 BTU/HR.
- ③ – CABIN AT 75°F (24°C). 3 CREW MEMBERS ONLY. BRIGHT DAY, SOLAR IRRADIATION, SOLAR LOAD x 2620 BTU/HR. ELECTRICAL LOAD x 5150 BTU/HR. GALLEY LOAD x 3000 BTU/HR.
- ④⑤ AND ⑥ – CABIN TEMP AT 70°F (21°C). NO CREW, NO PASSENGERS, CLOUDY DAY OR NIGHT. NO SOLAR IRRADIATION. NO ELECTRICAL LOAD. NO GALLEY LOAD.

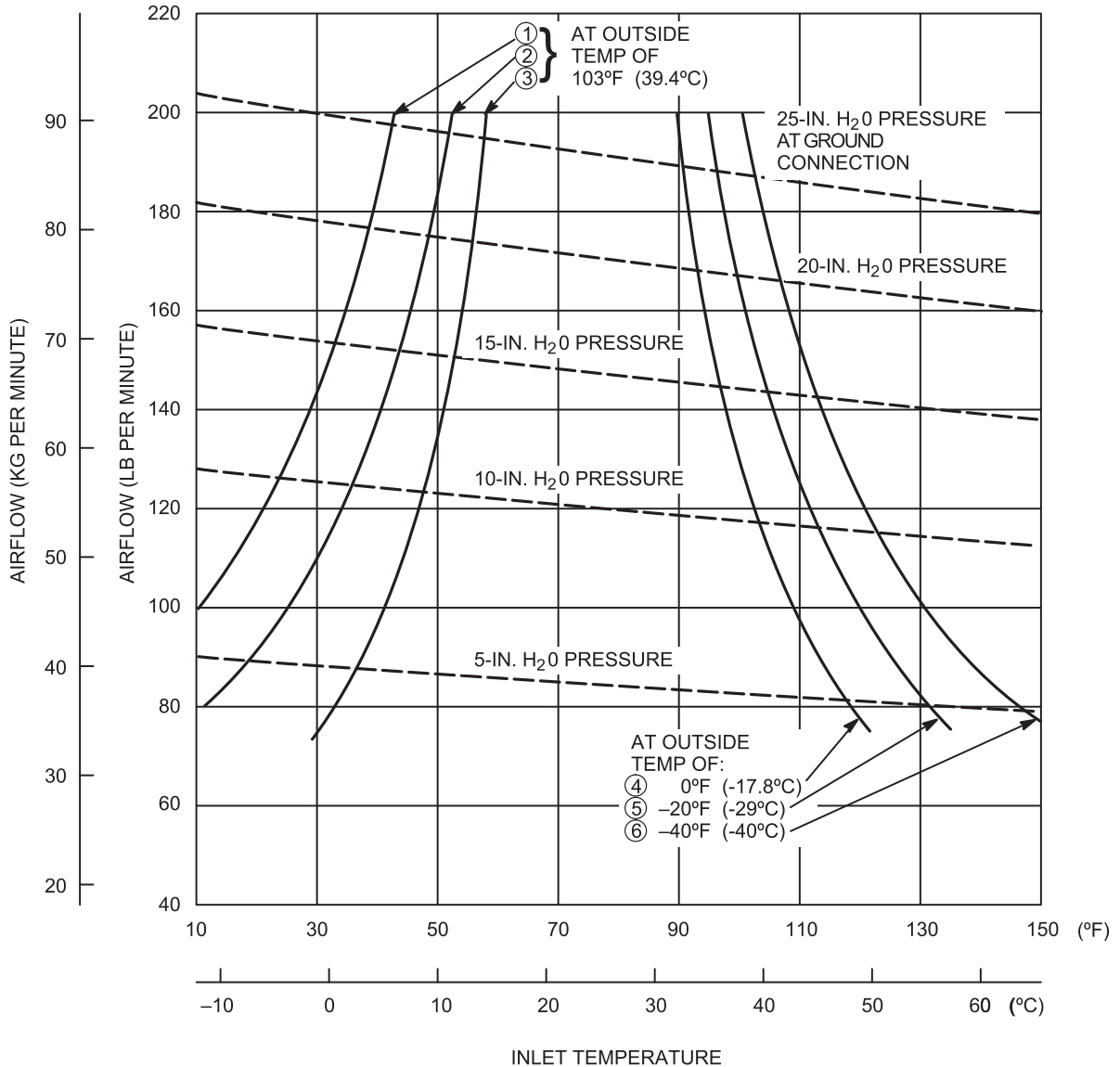

5.7 PRECONDITIONED AIRFLOW REQUIREMENTS MODEL MD-90-30/-30ER



- UNUSUAL BRAKING CONDITIONS NOT REFLECTED
- ESTIMATED FOR TOW VEHICLES WITH RUBBER TIRES
- COEFFICIENTS OF FRICTION (μ) APPROXIMATE

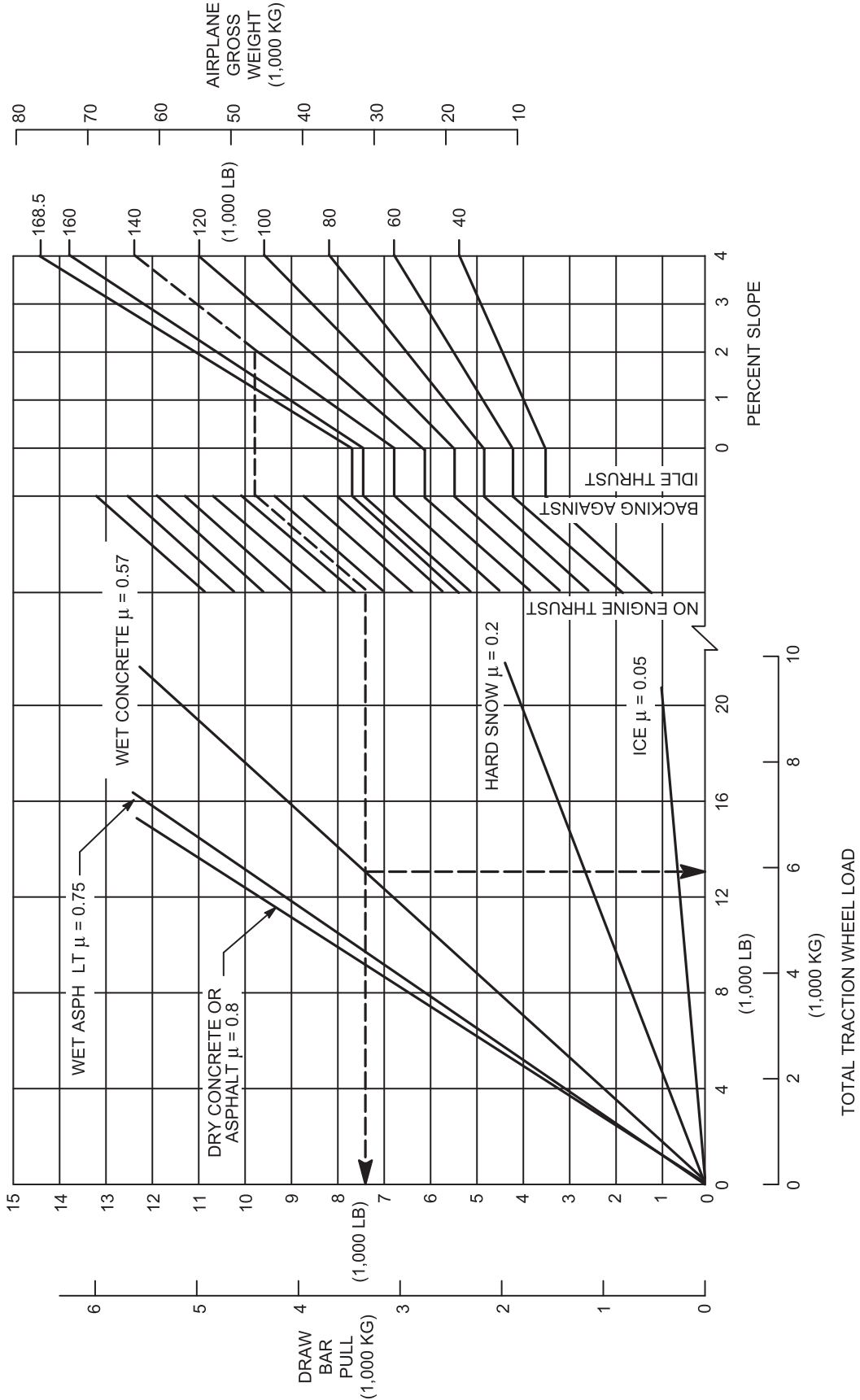

5.8 GROUND TOWING REQUIREMENTS MODEL MD-90-30/-30ER



This page intentionally left blank



6.0 OPERATING CONDITIONS

6.1 Jet Engine Exhaust Velocities and Temperatures

6.2 Airport and Community Noise



This page intentionally left blank

- NOTES:
1. THESE CONTOURS ARE TO BE USED AS GUIDELINES ONLY SINCE THE OPERATIONAL ENVIRONMENT VARIES GREATLY -- OPERATIONAL SAFETY ASPECTS ARE THE RESPONSIBILITY OF THE USER/PLANNER
 2. ALL VELOCITY VALUES ARE STATUTE MILES PER HOUR
 3. CROSSWINDS WILL HAVE CONSIDERABLE EFFECT ON CONTOURS
 4. SEA LEVEL STATIC -- STANDARD DAY -- ZERO RAMP GRADIENT
 5. INCLUDES EFFECTS OF TIRES IN COLD WEATHER
 6. BOTH ENGINES (V2500-D5) AT 950 LB THRUST EACH

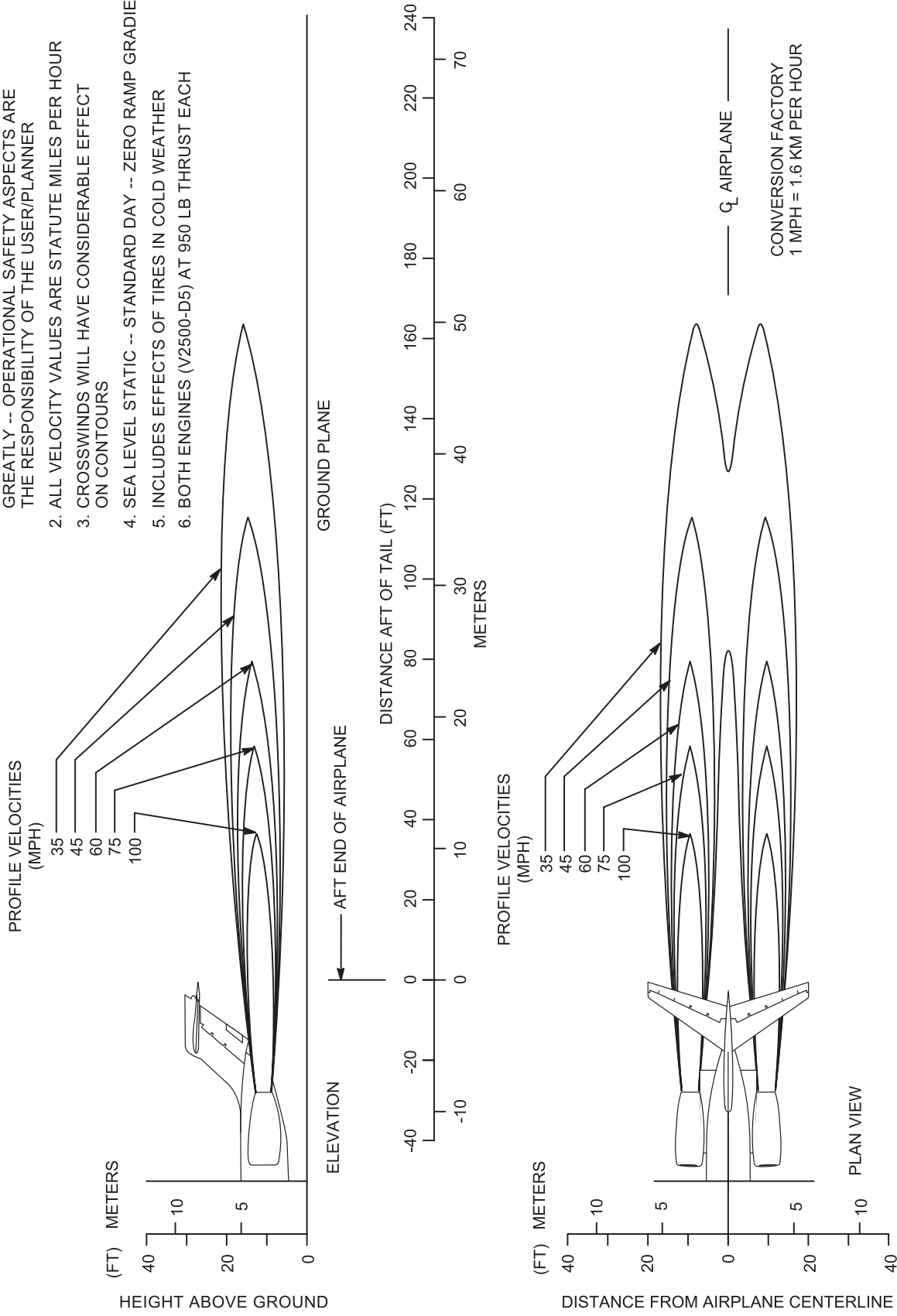

6.0 OPERATING CONDITIONS
6.1 JET ENGINE EXHAUST VELOCITIES AND TEMPERATURES
6.1.1 JET ENGINE EXHAUST VELOCITY CONTOURS, BREAKAWAY POWER (ESTIMATED)
MODEL MD-90-30

- NOTES:**
1. THESE CONTOURS ARE TO BE USED AS GUIDELINES ONLY SINCE THE OPERATIONAL ENVIRONMENT VARIES GREATLY -- OPERATIONAL SAFETY ASPECTS ARE THE RESPONSIBILITY OF THE USER/PLANNER
 2. ALL VELOCITY VALUES ARE STATUTE MILES PER HOUR
 3. CROSSWINDS WILL HAVE CONSIDERABLE EFFECT ON CONTOURS
 4. SEA LEVEL STATIC -- STANDARD DAY -- ZERO RAMP GRADIENT
 5. BOTH ENGINES (V2500-D5) AT 950 LB THRUST EACH

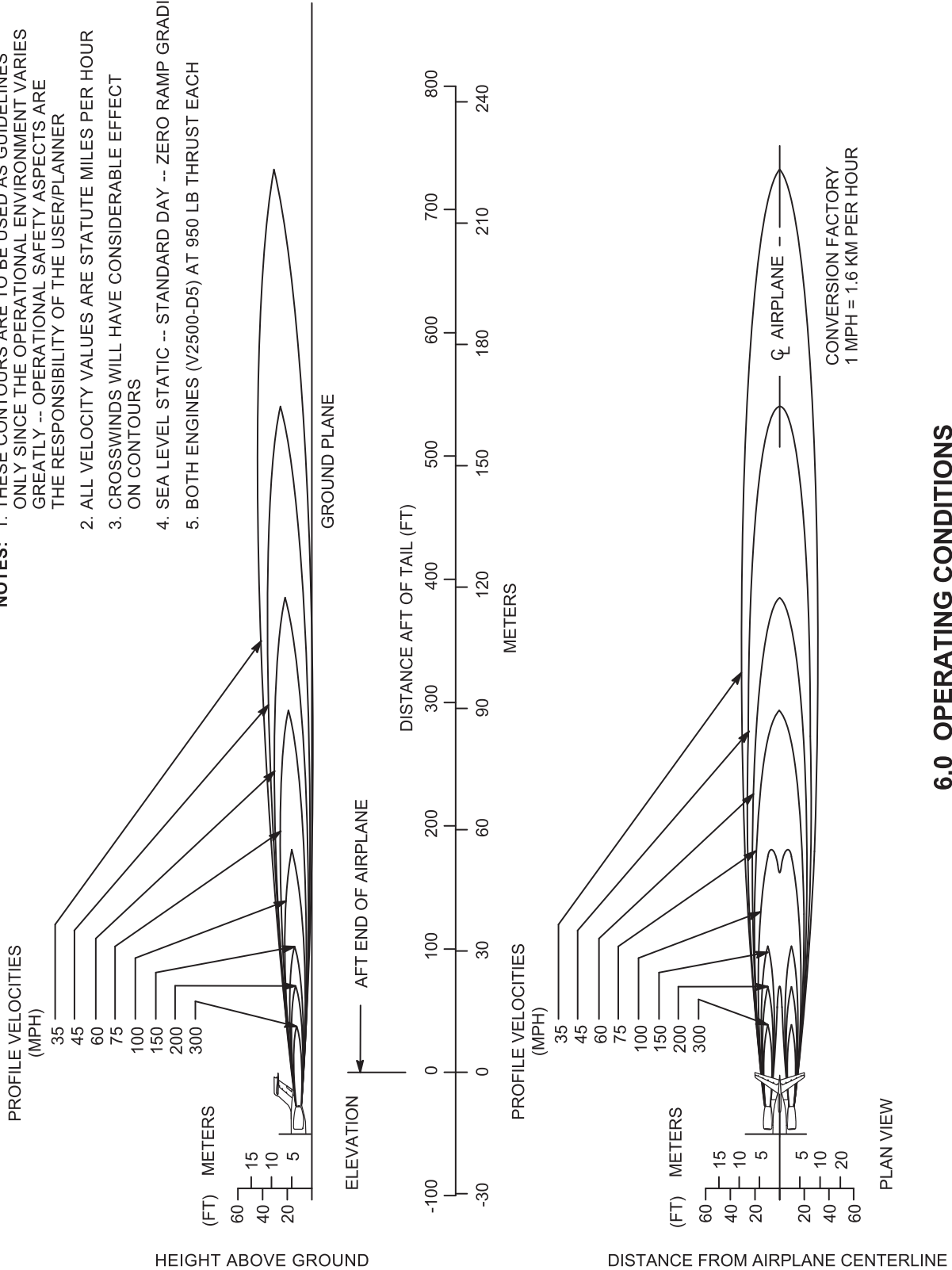

6.0 OPERATING CONDITIONS

6.1 JET ENGINE EXHAUST VELOCITIES AND TEMPERATURES

6.1.2 JET ENGINE EXHAUST VELOCITY CONTOURS, TAKEOFF POWER (ESTIMATED)

MODEL MD-90-30

NOTES: 1. THESE CONTOURS ARE TO BE USED AS GUIDELINES ONLY SINCE THE OPERATIONAL ENVIRONMENT VARIES GREATLY -- OPERATIONAL SAFETY ASPECTS ARE THE RESPONSIBILITY OF THE USER/PLANNER

2. ALL VELOCITY VALUES ARE STATUTE MILES PER HOUR ON CONTOURS

3. CROSSWINDS WILL HAVE CONSIDERABLE EFFECT

4. SEA LEVEL STATIC -- STANDARD DAY -- ZERO RAMP GRADIENT

5. BOTH ENGINES (V2500-D5) AT 950 LB THRUST EACH

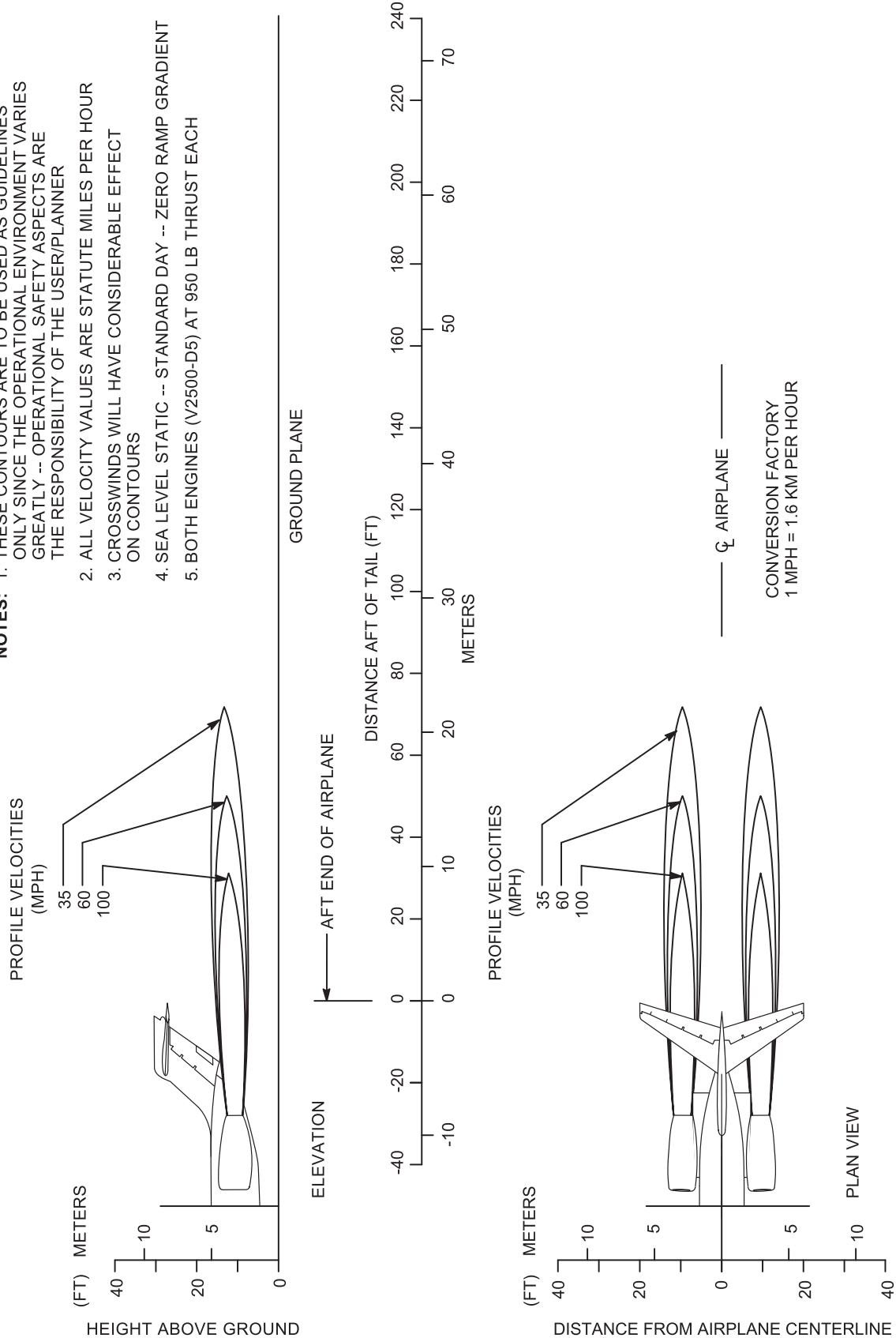

6.0 OPERATING CONDITIONS
6.1 JET ENGINE EXHAUST VELOCITIES AND TEMPERATURES
6.1.3 JET ENGINE EXHAUST VELOCITY CONTOURS, IDLE POWER (ESTIMATED)
MODEL MD-90-30



6.1.4 Jet Engine Exhaust Temperature

Jet engine exhaust temperature contour lines have not been presented because the adverse effects of exhaust temperature at any given position behind the aircraft fitted with these high-bypass engines are considerably less than the effects of exhaust velocity.



6.2 Airport and Community Noise

Airport noise is of major concern to the airport and community planner. The airport is a major element of the community's transportation system and, as such, is vital to its growth. However, the airport must also be a good neighbor, and this can be accomplished only with proper planning. Since aircraft noise extends beyond the boundaries of the airport, it is vital to consider the impact on surrounding communities. Many means have been devised to provide the planner with a tool to estimate the impact of airport operations. Too often they oversimplify noise to the point where the results become erroneous. Noise is not a simple subject; therefore, there are no simple answers.

The cumulative noise contour is an effective tool. However, care must be exercised to ensure that the contours, used correctly, estimate the noise resulting from aircraft operations conducted at an airport.

The size and shape of the single-event contours, which are inputs into the cumulative noise contours, are dependent upon numerous factors. They include:

1. Operational Factors

- (a) Aircraft Weight --- Aircraft weight is dependent on distance to be traveled, en route winds, payload, and anticipated aircraft delay upon reaching the destination.
- (b) Engine Power Settings — The rates of ascent and descent and the noise levels emitted at the source are influenced by the power setting used.
- (c) Airport Altitude — Higher airport altitude will affect engine performance and thus can influence noise.

2. Atmospheric Conditions — Sound Propagation

- (a) Wind --- With stronger headwinds, the aircraft can take off and climb more rapidly relative to the ground. Also, winds can influence the distribution of noise in surrounding communities.
- (b) Temperature and Relative Humidity --- The absorption of noise in the atmosphere along the transmission path between the aircraft and the ground observer varies with both temperature and relative humidity.

3. Surface Condition — Shielding, Extra Ground Attenuation (EGA)

Terrain --- If the ground slopes down after takeoff or up before landing, noise will be reduced since the aircraft will be at a higher altitude above the ground. Additionally, hills, shrubs, trees, and large buildings can act as sound buffers.



All of these factors can alter the shape and size of the contours appreciably. To demonstrate the effect of some of these factors, estimated noise level contours for two different operating conditions are shown below. These contours reflect a given noise level upon a ground level plane at runway elevation.

As indicated by these data, the contour size varies substantially with operating and atmospheric conditions. Most aircraft operations are, of course, conducted at less than maximum gross weights because average flight distances are much shorter than maximum aircraft range capability and average load factors are less than 100 percent. Therefore, in developing cumulative contours for planning purposes, it is recommended that the airlines serving a particular city be contacted to provide operational information.

In addition, there are no universally accepted methods for developing aircraft noise contours or for relating the acceptability of specific noise zones to specific land uses. It is therefore expected that noise contour data for particular aircraft and the impact assessment methodology will be changing. To ensure that currently available information of this type is used in any planning study, it is recommended that it be obtained directly from the Office of Environmental Quality in the Federal Aviation Administration in Washington, D.C.

It should be noted that the contours are shown here only to illustrate the impact of operating and atmospheric conditions and do not represent the single-event contour of the family of aircraft described in this document. It is expected that the cumulative contours will be developed as required by planners using the data and methodology applicable to their specific study.

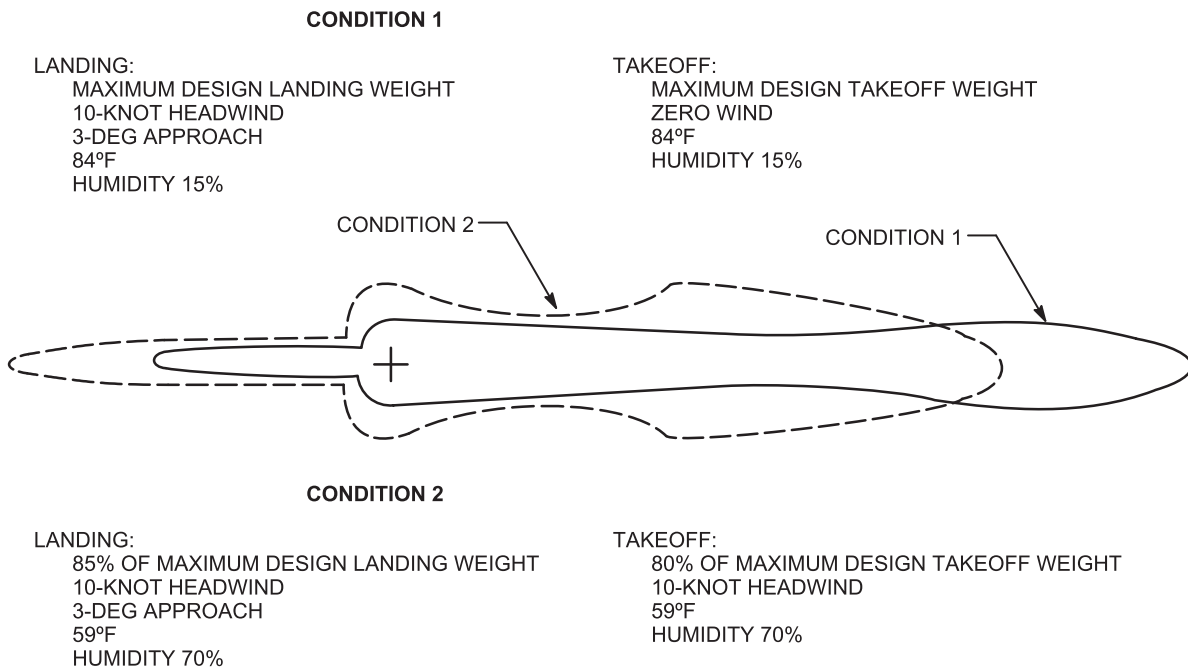



7.0 PAVEMENT DATA

7.1 General Information

7.2 Footprint

7.3 Maximum Pavement Loads

7.4 Landing Gear Loading on Pavement

7.5 Flexible Pavement Requirements

**7.6 Flexible Pavement Requirements, LCN
Conversion**

7.7 Rigid Pavement Requirements

**7.8 Rigid Pavement Requirements, LCN
Conversion**

**7.9 ACN-PCN Reporting System: Flexible
and Rigid Pavements**



This page intentionally left blank



7.0 PAVEMENT DATA

7.1 General Information

A brief description of the following pavement charts will be helpful in their use for airport planning. Each airplane configuration is shown with a minimum range of five loads imposed on the main landing gear to aid in interpolation between the discrete values shown. All curves for any single chart represent data based on rated loads and tire pressures considered normal and acceptable by current aircraft tire manufacturer's standards.

Section 7.2 presents basic data on the landing gear footprint configuration, maximum design taxi loads, and tire sizes and pressures.

Maximum pavement loads for certain critical conditions at the tire-ground interfaces are shown in Section 7.3.

Pavement requirements for commercial airplanes are customarily derived from the static analysis of loads imposed on the main landing gear struts. The chart in Section 7.4 is provided in order to determine these loads throughout the stability limits of the airplane at rest on the pavement. These main landing gear loads are used as the point of entry to the pavement design charts, interpolating load values where necessary.

The flexible pavement design curves (Section 7.5) are based on procedures set forth in Instruction Report No. S-77-1, "Procedures for Development of CBR Design Curves," dated June 1977, and as modified according to the methods described in FAA Advisory Circular 150/5320-6D, "Airport Pavement Design and Evaluation," dated July 7, 1995. Instruction Report No. S-77-1 was prepared by the U.S. Army Corps of Engineers Waterways Experiment Station, Soils and Pavements Laboratory, Vicksburg, Mississippi. The line showing 10,000 coverages is used to calculate Aircraft Classification Number (ACN).

The following procedure is used to develop the flexible pavement curves:

1. Having established the scale for pavement depth at the bottom and the scale for CBR at the top, an arbitrary line is drawn representing 6,000 annual departures.
2. Values of the aircraft gross weight are then plotted.
3. Additional annual departure lines are drawn based on the load lines of the aircraft gross weights already established.
4. An additional line representing 10,000 coverages (used to calculate the Aircraft Classification Number) is also placed.



Rigid pavement design curves (Section 7.7) have been prepared with the use of the Westergaard equation in general accordance with the relationships outlined in the 1955 Edition of "Design of Concrete-Airport Pavement" published by the Portland Cement Association, 33 W. Grand Ave., Chicago, Illinois, but modified to the new format described in the 1968 Portland Cement Association publication, "Computer Program for Airport Pavement Design" (Program PDILB) by Robert G. Packard.

The following procedure is used to develop the rigid pavement design curves such as that shown in Section 7.7:

1. Having established the scale for pavement thickness to the left and the scale for allowable working stress to the right, an arbitrary load line is drawn representing the main landing gear maximum weight to be shown.
2. All values of the subgrade modulus (k-values) are then plotted.
3. Additional load lines for the incremental values of weight on the main landing gear are then established on the basis of the curve for $k = 300$, already established.

All Load Classification Number (LCN) curves (Sections 7.6 and 7.8) have been plotted from data in the International Civil Aviation Organization (ICAO) Document 7290-AN/865/2, Aerodrome Manual, Part 2, "Aerodrome Physical Characteristics," 2nd Edition, 1965.

On the same charts showing LCN versus equivalent single wheel load, there are load plots for airplane Model MD-90-30 showing equivalent single wheel load versus pavement thickness for flexible pavements and versus radius of relative stiffness for rigid pavements.

Procedures and curves provided in the ICAO Aerodrome Manual – Part 2, Chapter 4 are used to determine equivalent single wheel loads for use in making LCN conversion of rigid pavement requirements.

Note: Pavement requirements are presented for loads, tires and tire pressures presently certified for commercial usage. All curves represent data at a constant specified tire pressure.

The ACN-PCN system (Section 7.9) as referenced in ICAO Annex 14, "Aerodromes," 3rd Edition, July 1999, provides a standardized international airplane/pavement rating system replacing the various S, T, TT, LCN, AUW, ISWL, etc., rating systems used throughout the world. ACN is the Aircraft Classification Number and PCN is the corresponding Pavement Classification Number. An aircraft having an ACN equal to or less than the PCN can operate without restriction on the pavement. Numerically, the ACN is two times the derived single wheel load expressed in thousands of kilograms, where the derived single wheel load is defined as the load on a single tire inflated to 1.25 MPa (181 psi) that would have the same pavement requirements as the aircraft. Computationally, the ACN-PCN system uses PCA program PDILB for rigid pavements and S-77-1 for flexible pavements to calculate ACN values. The method of pavement evaluation is left up to the airport with the results of its evaluation presented as follows:



PCN	PAVEMENT CLASSIFICATION NUMBER	CODE	PAVEMENT TYPE	CODE	SUBGRADE CATEGORY	CODE	TIRE PRESSURE CATEGORY	CODE	EVALUATION METHOD
(s)	(BEARING STRENGTH FOR UN-RESTRICTED OPERATIONS)	R F	RIGID FLEXIBLE	A B C D	HIGH (k = 150 MN/M ³) (OR CBR = 15) MEDIUM (k = 80 MN/M ³) (OR CBR = 10) LOW (k = 40 MN/M ³) (OR CBR = 6) ULTRA LOW (K = 20 MN/M ³) (OR CBR = 3)	W X Y Z	HIGH (NO LIMIT) MEDIUM (LIMITED TO 1.75 MPa) LOW (LIMITED TO 1.25 MPa) VERY LOW (LIMITED TO 0.5 MPa)	T U	TECHNICAL USING AIRCRAFT

This document has been partially revised to incorporate key information for the MD-90-30ER with a maximum ramp weight of 168,500 lbs (76,430 kgs). Due to the fact that there were only two aircraft delivered in this higher weight configuration when production of the model ceased, only limited charts in this section have been revised for the MD-90-30ER. The modified/new charts are limited to the following:

- 7.2 Footprint
- 7.3 Maximum Pavement Loads
- 7.4 Landing Gear Loading on Pavement
- 7.9.3 Aircraft Classification Number - Flexible Pavement (168,500 lbs)
- 7.9.4 Aircraft Classification Number - Rigid Pavement (168,500 lbs)

Contact Airport Technology for any additional data needed for this high weight model at:

Attention: Airport Compatibility
 Telephone: 425-237-1004
 Fax: 206-662-0280
 Email: AirportCompatibility@boeing.com
 Website: www.boeing.com/airports



	MD-90-30	MD-90-30ER
MAXIMUM DESIGN TAXI WEIGHT	157,000 LB (71,214 KG)	168,500 LB (76,430 KG)
PERCENT OF WEIGHT ON MAIN GEAR	SEE SECTION 7.4	SEE SECTION 7.4
NOSE TIRE SIZE	26 x 6.6 12 PR	26 x 6.6 12 PR
NOSE TIRE PRESSURE	160 PSI (11.3 KG/CM ²)	170 PSI (11.9 KG/CM ²)
MAIN GEAR TIRE SIZE	H 44.5 x 16.5 — 21 26 PR	H 44.5 x 16.5 — 21 26 PR
MAIN GEAR TIRE PRESSURE	190 PSI (13.4 KG/CM ²)	193 PSI (13.6 KG/CM ²)

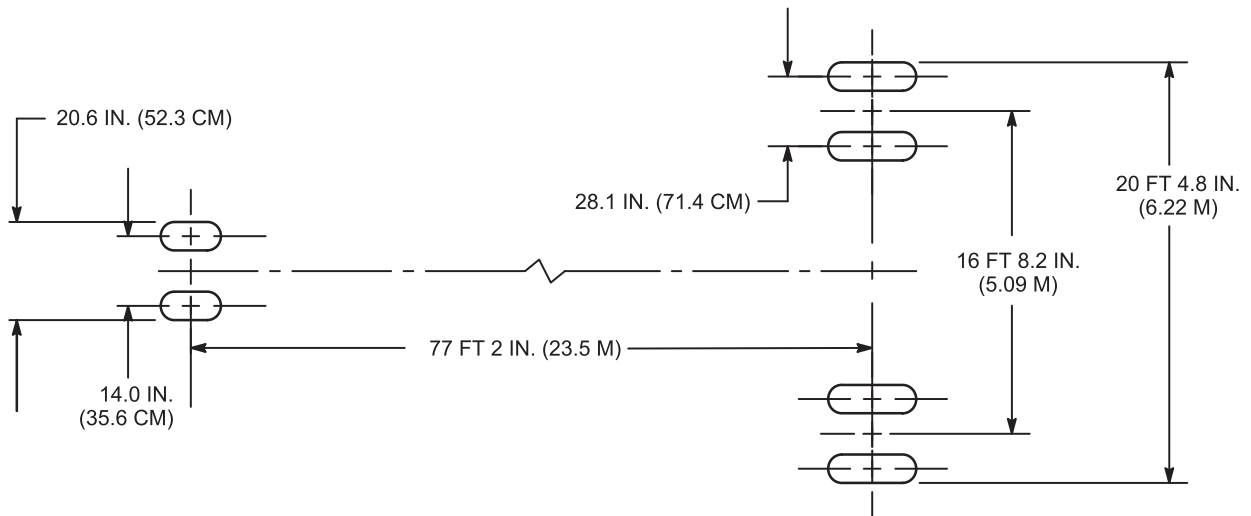

7.2 FOOTPRINT MODEL MD-90-30/-30ER

LEGEND: V_{NG} = MAXIMUM VERTICAL NOSEGEAR GROUND LOAD AT MOST FORWARD C.G.
 V_{MG} = MAXIMUM VERTICAL MAIN GEAR GROUND LOAD AT MOST AFT C.G.
 H = MAXIMUM HORIZONTAL GROUND LOAD FROM BRAKING

NOTE: ALL LOADS CALCULATED USING AIRPLANE MAXIMUM DESIGN TAXI WEIGHT

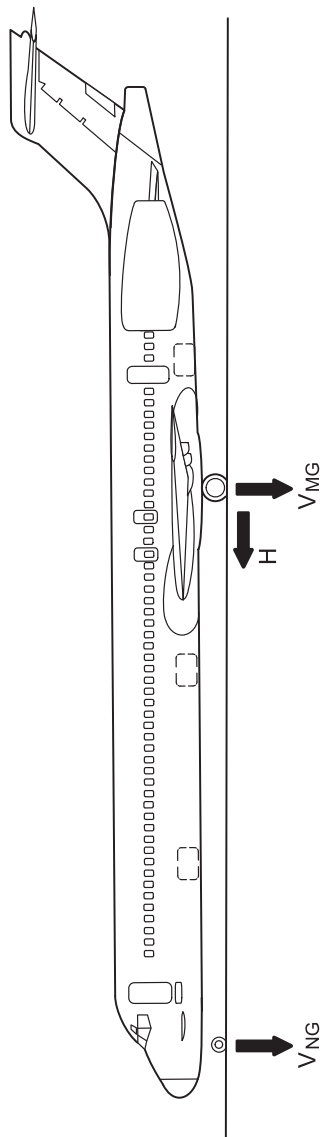

MODEL	MAXIMUM DESIGN TAXI WEIGHT		V_{NG}				V_{MG} PER STRUT (2) AFT C.G.		H PER STRUT (2)				
	LB	KG	STATIC AT MOST FORWARD C.G.	STATIS + BRAKING 10 FT/SEC ² DECLERATION	MAXIMUM LOAD OCCURRING AT STATIC AFT C.G.	AT STEADY BRAKING 10 FT/SEC ² DECELERATION	AT INSTANTANEOUS BRAKING (COEFF. OF FRICTION 0.8)	LB	KG	LB	KG	LB	KG
MD-90-30	157,000	6,670	14,710	20,230	75,740	24,400	56,050	25,420					
MD-90-30ER	168,500	6,952	15,328	21,205	79,167	26,168	63,334	28,728					

7.3 MAXIMUM PAVEMENT LOADS MODEL MD-90-30/-30ER



7.4 Landing Gear Loading on Pavement

To obtain the airplane weight on the following pavement charts, an equivalent main landing gear weight must be determined.

In the example shown for the MD-90-30 in Section 7.4.1, for a gross weight of 105,000 lb at 96.48% weight on main gear, the equivalent weight on the main landing gear is 101,200 lb.



NOTE: UNSHADED AREAS REPRESENT OPERATIONAL LIMITS

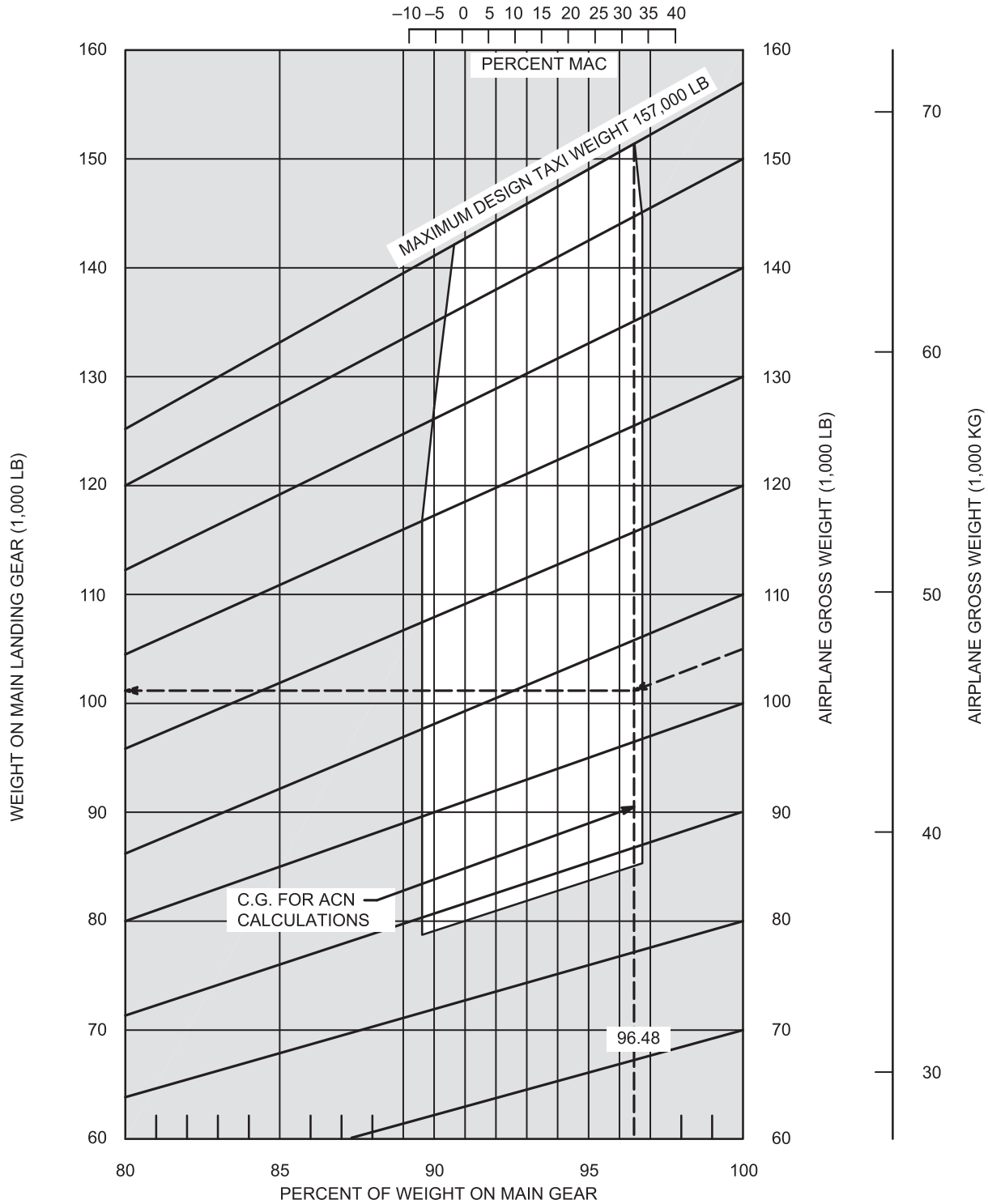

7.4.1 LANDING GEAR LOADING ON PAVEMENT MODEL MD-90-30



NOTE: UNSHADED AREAS REPRESENT OPERATIONAL LIMITS

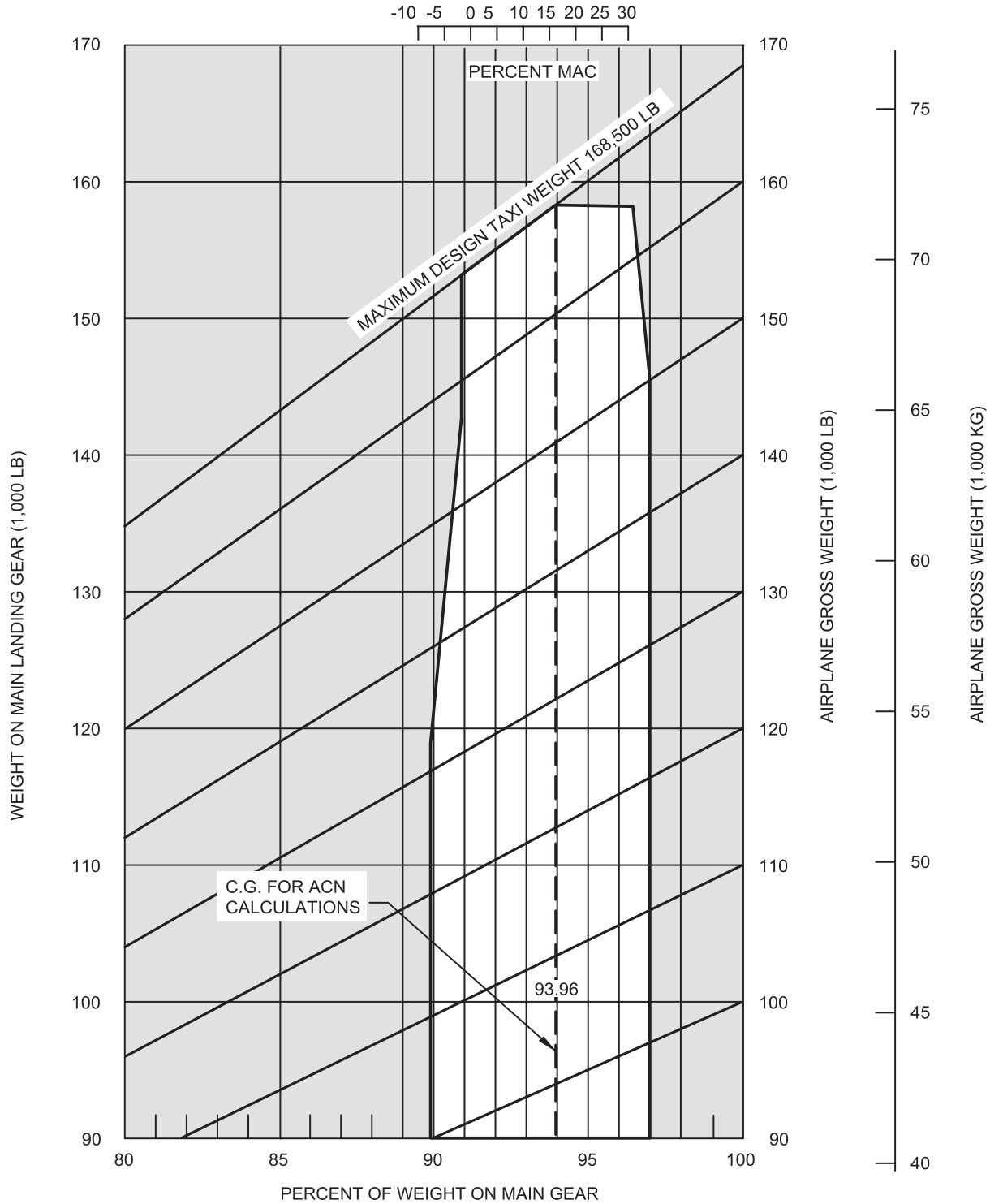

7.4.2 LANDING GEAR LOADING ON PAVEMENT MODEL MD-90-30ER



7.5 Flexible Pavement Requirements -- U.S. Army Corps of Engineers Method (S-77-1)

The following flexible-pavement design chart presents data for 5 incremental main-gear weights at a constant main-gear tire pressure of 200 psi (14.1 kg/cm²).

In the example shown for the MD-90-30, for a CBR of 7.0, a main-gear load of 100,000 lb, and an annual departure level of 6,000, the required pavement thickness is 24.5 inches.

The line showing 10,000 coverages is used for ACN calculations (see section 7.9).

The FAA design method uses a similar procedure using total airplane weight instead of weight on main landing gear. The equivalent main gear loads for a given airplane weight can be calculated from Section 7.4.



NOTES: H44.5 x 16.5-21, 26 PR TIRES
TIRE PRESSURE CONSTANT AT 200 PSI (14.1 KG/CM²)

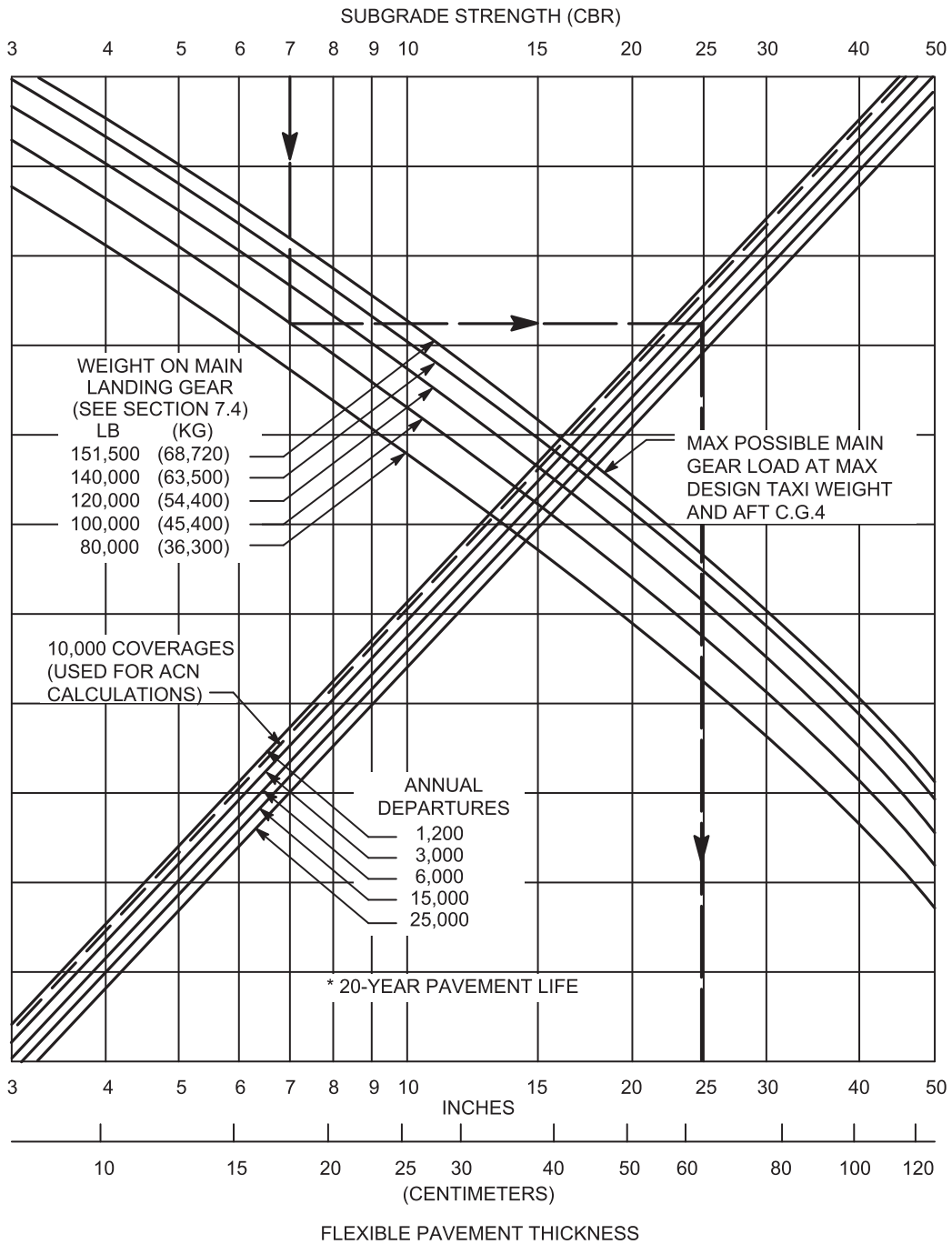

**7.5.1 FLEXIBLE PAVEMENT REQUIREMENTS
U.S. ARMY CORPS OF ENGINEERS/FAA DESIGN METHOD
MODEL MD-90-30**



7.6 Flexible Pavement Requirements, LCN Conversion

To determine the airplane weight that can be accommodated on a particular flexible airport pavement, both the LCN of the pavement and the thickness (h) of the pavement must be known.

In the example shown for the MD-90-30, the flexible pavement thickness is 30 inches and the LCN is 70. For these conditions, the weight on the main landing gear is 110,000 pounds.

Note: If the resulting aircraft LCN is not more than 10 percent above the published pavement LCN, the bearing strength of the pavement can be considered sufficient for unlimited use by the airplane. The figure of 10 percent has been chosen as representing the lowest degree of variation in LCN which is significant. (Reference: ICAO Aerodrome Design Manual, Part 2, "Aerodrome Physical Characteristics," Chpt. 4, Para. 4.1.5.7v, 2nd Edition, 1965.)



- H44.5 x 16.5-21, 26 PR TIRES
- TIRE PRESSURE CONSTRAINT AT 200 PSI

NOTE: EQUIVALENT SINGLE WHEEL LOADS ARE DERIVED BY METHODS SHOWN IN ICAO AERODROME MANUAL, PART 2, PARA. 4.1.3.

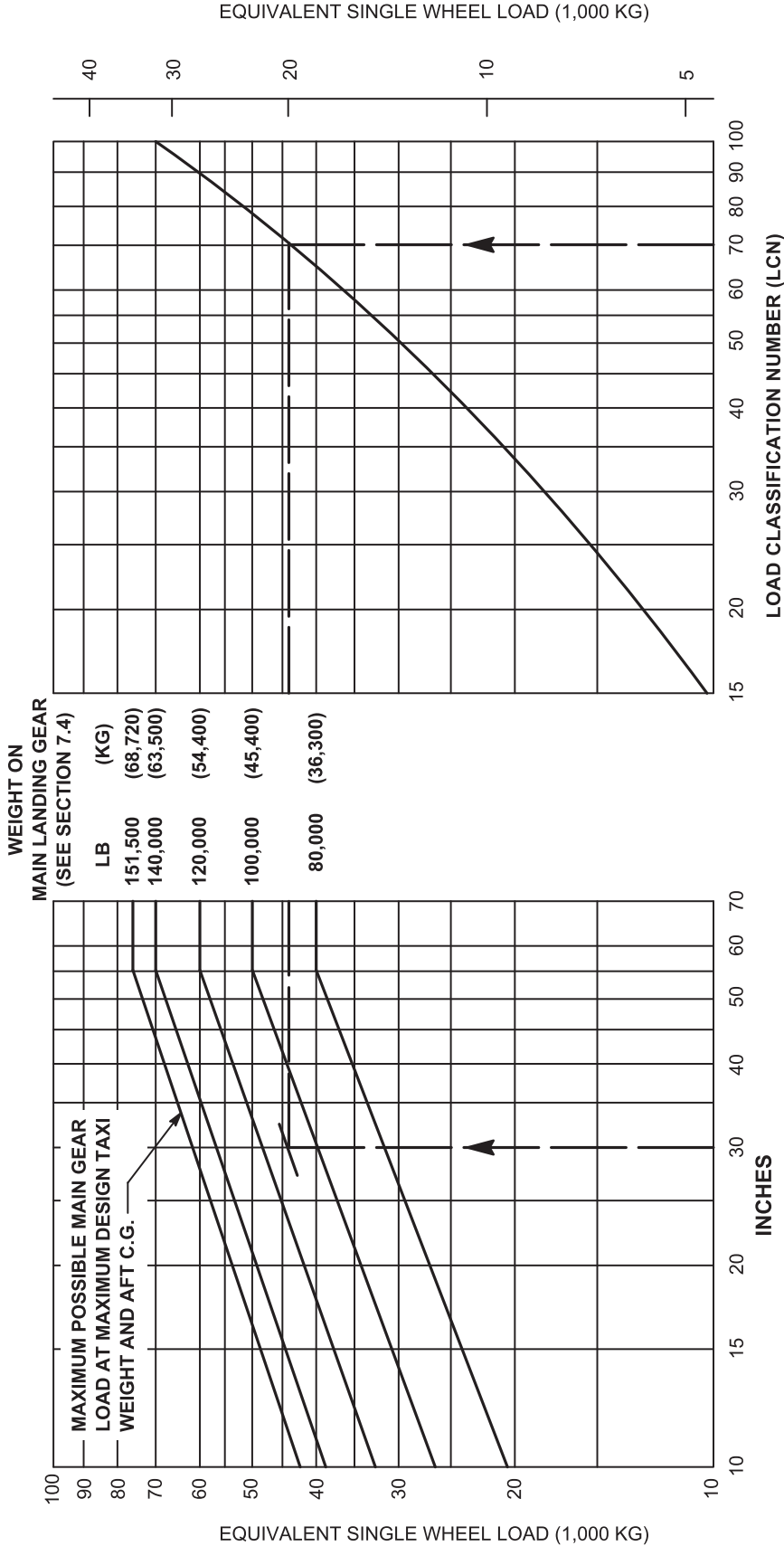

7.6.1 FLEXIBLE PAVEMENT REQUIREMENTS, LCN CONVERSION MODEL MD-90-30



7.7 Rigid Pavement Requirements, Portland Cement Association Design Method

The following rigid-pavement design chart presents data for 5 incremental main-gear weights at a constant main-gear tire pressure of 200 psi (14.1 kg/cm²).

In the example shown for the MD-90-30, for an allowable working stress of 400 psi, a main-gear load of 127,000 lb, and a subgrade strength k of 150, the required rigid-pavement thickness is 12 inches.



NOTES: H44.5 x 16.5-21, 26 PR TIRES
TIRE PRESSURE CONSTANT AT 200 PSI (14.1 KG/CM²)

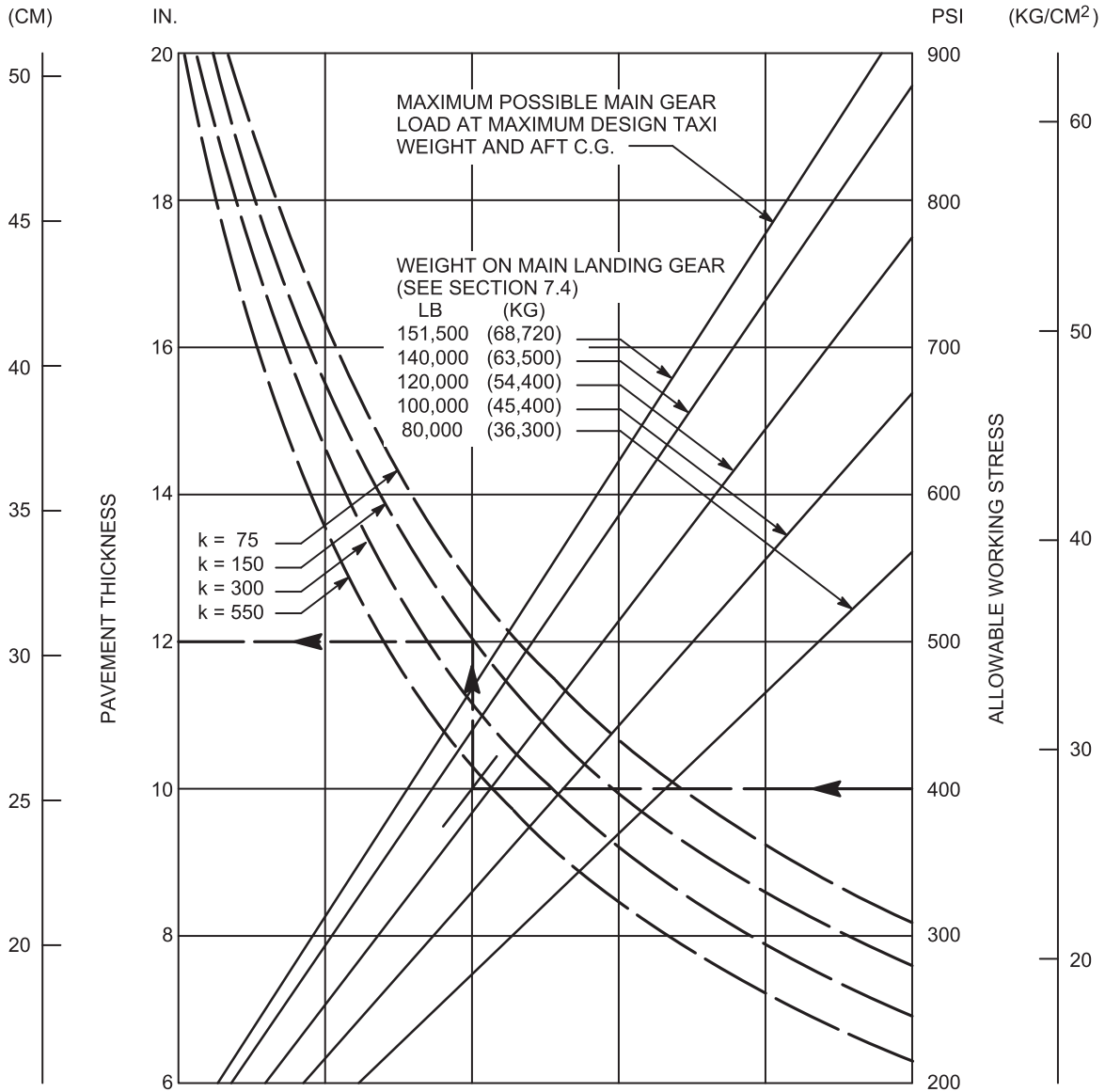

NOTE: THE VALUES OBTAINED BY USING THE MAX LOAD REFERENCE LINE AND ANY VALUES OF k ARE EXACT. FOR LOADS LESS THAN MAXIMUM, THE CURVES ARE EXACT FOR k = 300, BUT DEVIATE SLIGHTLY FOR OTHER VALUES OF k.

REF: "DESIGN OF CONCRETE AIRPORT PAVEMENT" AND "COMPUTER PROGRAM FOR AIRPORT PAVEMENT DESIGN -- PROGRAM PDILB," PORTLAND CEMENT ASSOCIATION.

7.7.1 RIGID PAVEMENT REQUIREMENTS, PORTLAND CEMENT ASSOCIATION DESIGN METHOD MODEL MD-90-30



7.8 Rigid Pavement Requirements, LCN Conversion

To determine the airplane weight that can be accommodated on a particular rigid airport pavement, both the LCN of the pavement and the radius of relative stiffness must be known.

In the example shown in section 7.8.2, the rigid pavement radius of relative stiffness is 35 inches and the LCN is 70. For these conditions, the weight on the main landing gear is 115,000 pounds.

Note: If the resulting aircraft LCN is not more than 10 percent above the published pavement LCN, the bearing strength of the pavement can be considered sufficient for unlimited use by the airplane. The figure of 10 percent has been chosen as representing the lowest degree of variation in LCN which is significant. (Reference: ICAO Aerodrome Design Manual, Part 2, "Aerodrome Physical Characteristics," Chpt. 4, Para. 4.1.5.7v, 2nd Edition, 1965.)



RADIUS OF RELATIVE STIFFNESS (ℓ)
VALUES IN INCHES

$$\ell = \sqrt[4]{\frac{Ed^3}{12(1-\mu^2)k}} = 24.1652 \sqrt[4]{\frac{d^3}{k}}$$

WHERE: E = YOUNG'S MODULUS = 4×10^6 PSI
 k = SUBGRADE MODULUS, LB/IN.³
 d = RIGID-PAVEMENT THICKNESS, IN.
 μ = POISSON'S RATIO = 0.15

d (IN.)	k = 75	k = 100	k = 150	k = 200	k = 250	k = 300	k = 350	k = 400	k = 500	k = 550
6.0	31.48	29.30	26.47	24.63	23.30	22.26	21.42	20.72	19.59	19.13
6.5	33.43	31.11	28.11	26.16	24.74	23.64	22.74	22.00	20.80	20.31
7.0	35.34	32.89	29.72	27.65	26.15	24.99	24.04	23.25	21.99	21.47
7.5	37.22	34.63	31.29	29.12	27.54	26.32	25.32	24.49	23.16	22.61
8.0	39.06	36.35	32.85	30.57	28.91	27.62	26.58	25.70	24.31	23.74
8.5	40.88	38.04	34.37	31.99	30.25	28.91	27.81	26.90	25.44	24.84
9.0	42.67	39.71	35.88	33.39	31.58	30.17	29.03	28.08	26.55	25.93
9.5	44.43	41.35	37.36	34.77	32.89	31.42	30.23	29.24	27.65	27.00
10.0	46.18	42.97	38.83	36.14	34.17	32.65	31.42	30.39	28.74	28.06
10.5	47.90	44.57	40.28	37.48	35.45	33.87	32.59	31.52	29.81	29.11
11.0	49.60	46.16	41.71	38.81	36.71	35.07	33.75	32.64	30.87	30.14
11.5	51.28	47.72	43.12	40.13	37.95	36.26	34.89	33.74	31.91	31.16
12.0	52.94	49.27	44.52	41.43	39.18	37.44	36.02	34.84	32.95	32.17
12.5	54.59	50.80	45.90	42.72	40.40	38.60	37.14	35.92	33.97	33.17
13.0	56.22	52.32	47.27	43.99	41.61	39.75	38.25	36.99	34.99	34.16
13.5	57.83	53.82	48.63	45.26	42.80	40.89	39.35	38.06	35.99	35.14
14.0	59.43	55.31	49.98	46.51	43.98	42.02	40.44	39.11	36.99	36.12
14.5	61.02	56.78	51.31	47.75	45.16	43.15	41.51	40.15	37.97	37.08
15.0	62.59	58.25	52.63	48.98	46.32	44.26	42.58	41.19	38.95	38.03
15.5	64.15	59.70	53.94	50.20	47.47	45.36	43.64	42.21	39.92	38.98
16.0	65.69	61.13	55.24	51.41	48.62	46.45	44.70	43.23	40.88	39.92
16.5	67.23	62.56	56.53	52.61	49.75	47.54	45.74	44.24	41.84	40.85
17.0	68.75	63.98	57.81	53.80	50.88	48.61	46.77	45.24	42.78	41.78
17.5	70.26	65.38	59.08	54.98	52.00	49.68	47.80	46.23	43.72	42.70
18.0	71.76	66.78	60.34	56.16	53.11	50.74	48.82	47.22	44.66	43.61
19.0	74.73	69.54	62.84	58.48	55.31	52.84	50.84	49.17	46.51	45.41
20.0	77.66	72.27	65.30	60.77	57.47	54.91	52.84	51.10	48.33	47.19
21.0	80.55	74.96	67.74	63.04	59.62	56.96	54.81	53.01	50.13	48.95
22.0	83.41	77.63	70.14	65.28	61.73	58.98	56.75	54.89	51.91	50.69
23.0	86.24	80.26	72.52	67.49	63.83	60.98	58.68	56.75	53.67	52.41
24.0	89.04	82.86	74.87	69.68	65.90	62.96	60.58	58.59	55.41	54.11
25.0	91.81	85.44	77.20	71.84	67.95	64.92	62.46	60.41	57.14	55.79

**7.8.1 RADIUS OF RELATIVE STIFFNESS
(REFERENCE: PORTLAND CEMENT ASSOCIATION)**



- H44.5 x 16.5-21, 26 PR TIRES
- TIRE PRESSURE CONSTRAINT AT 200 PSI

NOTE: EQUIVALENT SINGLE WHEEL LOADS ARE DERIVED BY METHODS SHOWN IN ICAO AERODROME MANUAL, PART 2, PARA. 4.1.3.

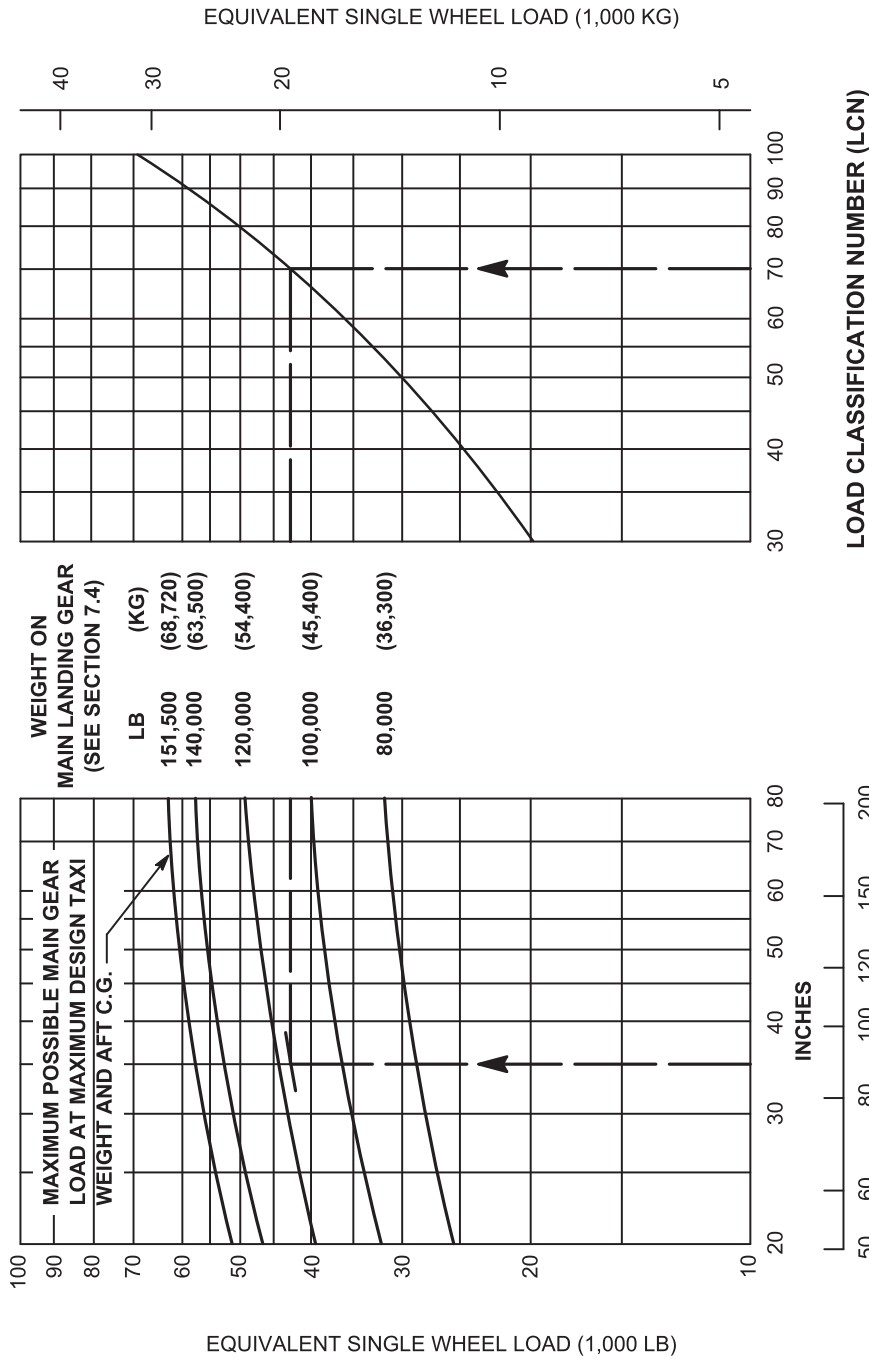

RADIUS OF RELATIVE STIFFNESS (CENTIMETERS)

7.8.2 RIGID PAVEMENT REQUIREMENTS, LCN CONVERSION MODEL MD-90-30



7.8.3 Radius of Relative Stiffness (Other values of E and ℓ)

The chart of Section 7.8.1 presents ℓ -values based on Young's modulus (E) of 4,000,000 psi and Poisson's ratio (μ of 0.15). For convenience in finding ℓ -values based on other values of E and μ , the curves of Section 7.8 are included. For example, to find an ℓ -value based on an E of 3,000,000 psi, the "E" factor of 0.931 is multiplied by the ℓ -value found in the table of Section 7.8.1. The effect of variations of μ on the ℓ -value is treated in a similar manner.

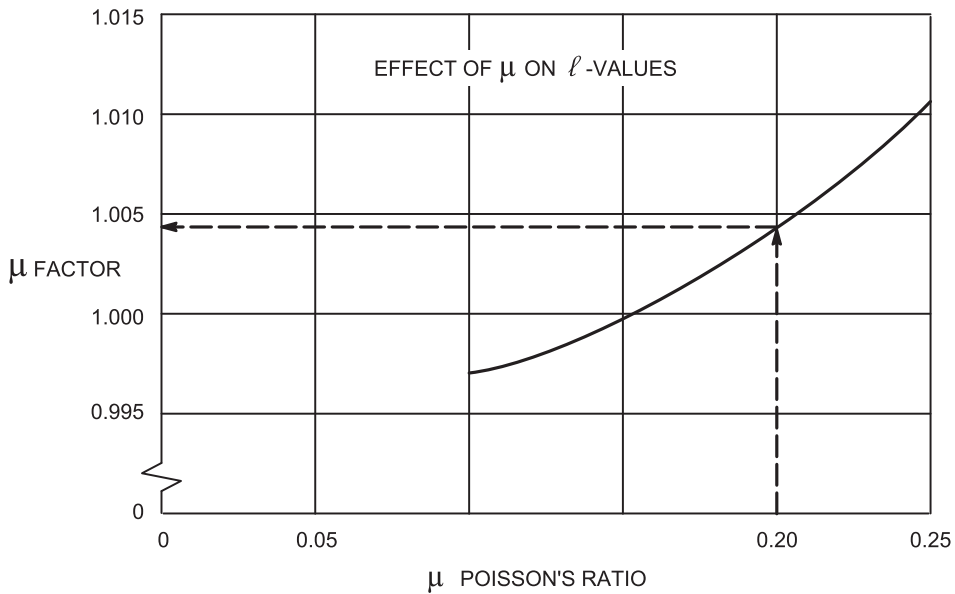
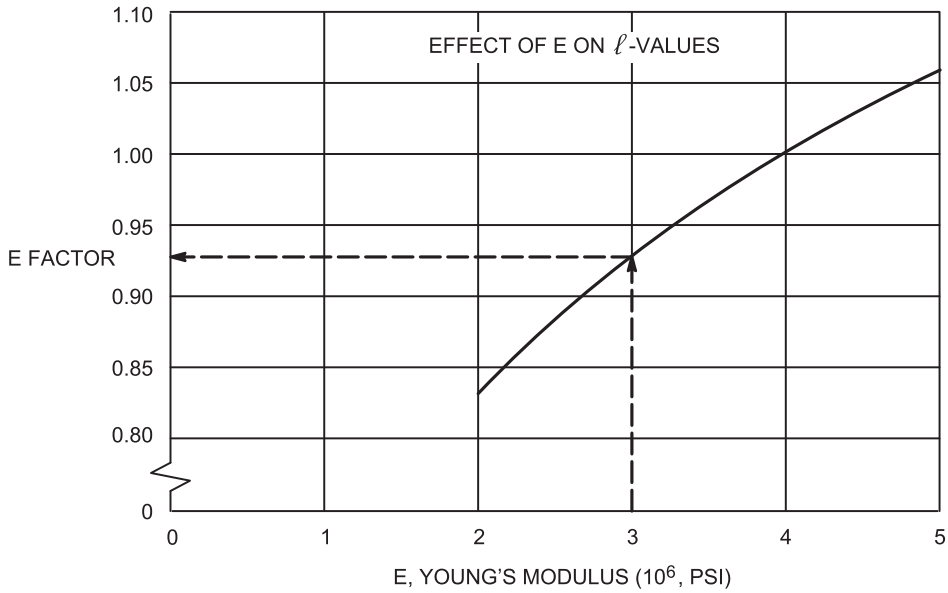

NOTE: BOTH CURVES ON THIS PAGE ARE USED TO ADJUST THE ℓ -VALUES OF TABLE 7.8.1

7.8.4 EFFECT OF E AND μ ON ℓ -VALUES



7.9 ACN-PCN Reporting System: Flexible and Rigid Pavements

To determine the ACN of an aircraft on flexible or rigid pavement, both the aircraft gross weight and the subgrade strength category must be known. As an example, referring to Section 7.9.1, for an aircraft gross weight of 130,000 pounds and low subgrade strength, the ACN for flexible pavement is 39. Referring to Section 7.9.3, for the same gross weight and subgrade strength, the ACN for rigid pavement is 43.

Note: An aircraft with an ACN equal to or less than the reported PCN can operate on the pavement subject to any limitations on the tire pressure. (Reference: ICAO Annex 14, "Aerodromes," 3rd Edition, July 1999.)

The following table provides ACN data in tabular format similar to the one used by ICAO in the "Aerodrome Design Manual Part 3, Pavements".

AIRCRAFT TYPE	ALL-UP MASS/ OPERATING MASS EMPTY LB (KG)	ON ONE MAIN GEAR LEG (%)	TIRE PRESSURE PSI (MPa)	ACN FOR RIGID PAVEMENT SUBGRADES -- MN/m ³				ACN FOR FLEXIBLE PAVEMENT SUBGRADES -- CBR			
				HIGH 150	MEDIUM 80	LOW 40	ULTRA LOW 20	HIGH 15	MEDIUM 10	LOW 6	ULTRA LOW 3
MD-90-30	157,000 (71,214) 88,171 (39,994)	48.24	200 (1.4)	49	51	53	55	42	46	50	53
				25	26	27	28	21	22	24	28
MD-90-30ER	168,500 (76,430) 89,059 (40,396)	46.98	193 (1.33)	51	53	55	57	44	48	52	55
				24	25	26	27	20	21	24	27



NOTES: • H44.5 x 16.5-21, 26 PR TIRES
 • TIRE PRESSURE CONSTRAINT AT 200 PSI (14.1 KG/CM²)

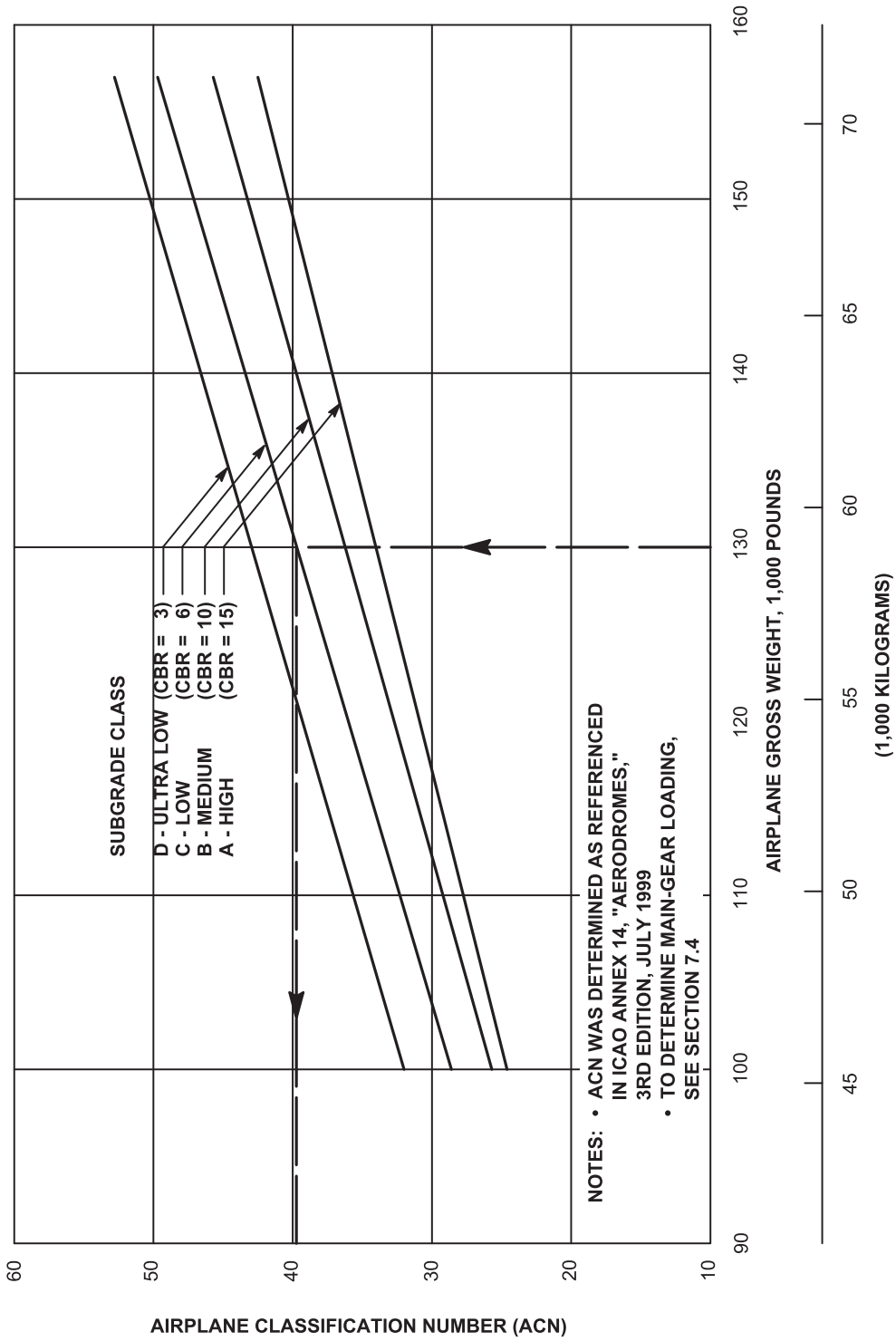

NOTES: • ACN WAS DETERMINED AS REFERENCED IN ICAO ANNEX 14, "AERODROMES," 3RD EDITION, JULY 1999
 • TO DETERMINE MAIN-GEAR LOADING, SEE SECTION 7.4

7.9.1 AIRCRAFT CLASSIFICATION NUMBER -- FLEXIBLE PAVEMENT (157,000 LBS)
 MODEL MD-90-30

- NOTES:
- H44.5 x 16.5-21, 26 PR TIRES
 - TIRE PRESSURE CONSTRAINT AT 193 PSI (13.6 KG/CM²)

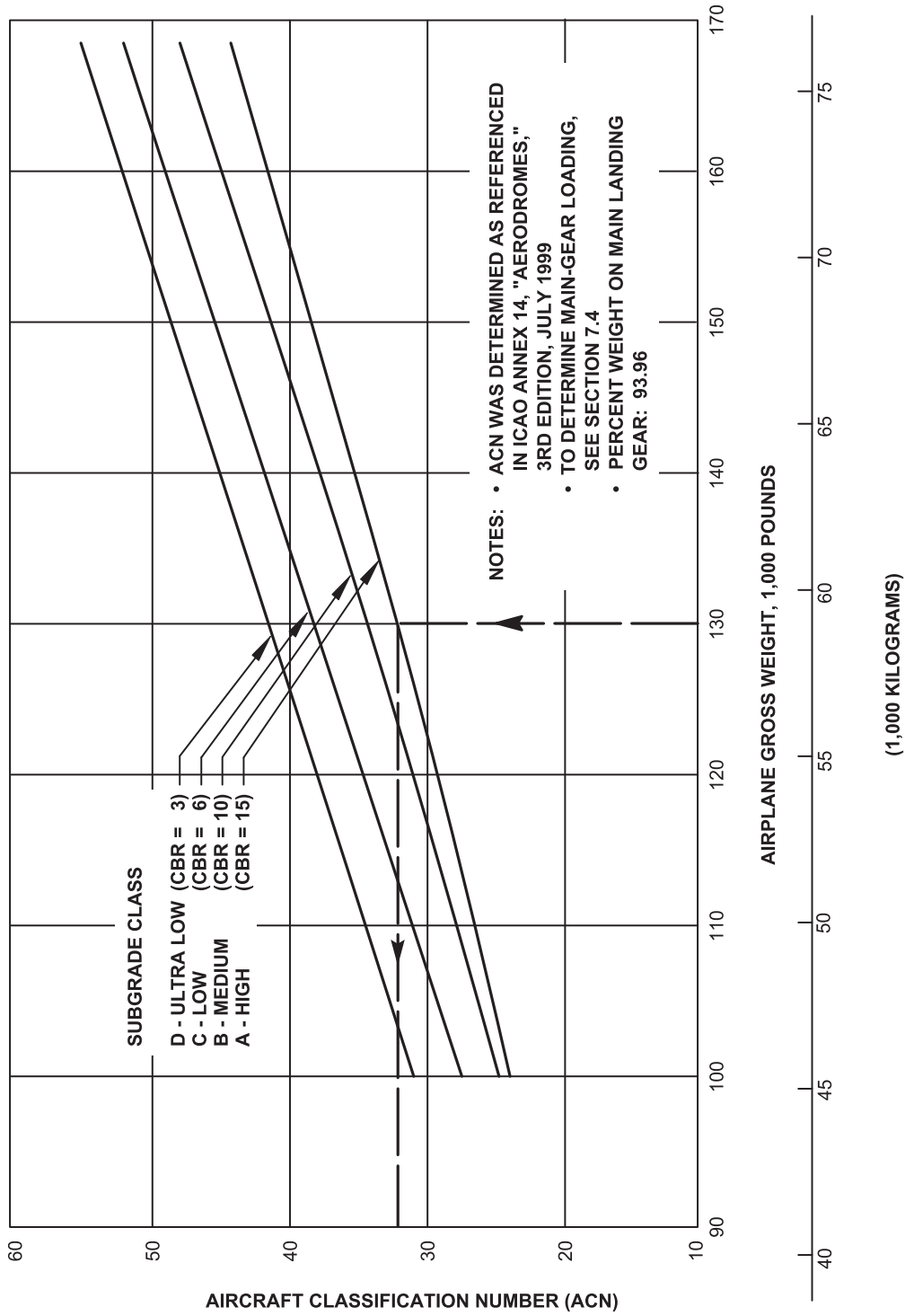

**7.9.2 AIRCRAFT CLASSIFICATION NUMBER -- FLEXIBLE PAVEMENT (168,500 LBS)
MODEL MD-90-30ER**



NOTES: • H44.5 x 16.5-21, 26 PR TIRES
 • TIRE PRESSURE CONSTRAINT AT 200 PSI (14.1 KG/CM²)

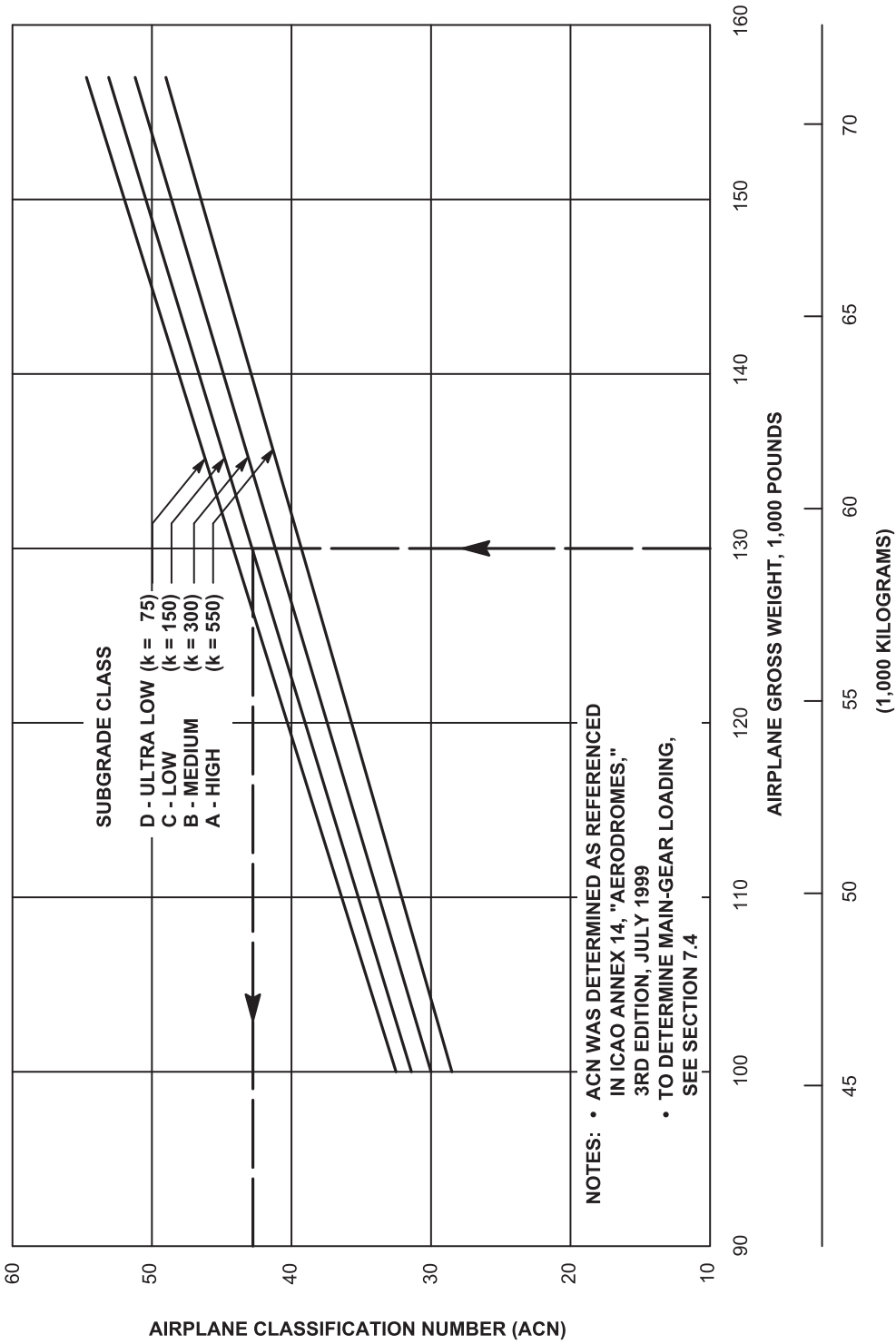

NOTES: • ACN WAS DETERMINED AS REFERENCED IN ICAO ANNEX 14, "AERODROMES," 3RD EDITION, JULY 1999
 • TO DETERMINE MAIN-GEAR LOADING, SEE SECTION 7.4

7.9.3 AIRCRAFT CLASSIFICATION NUMBER -- RIGID PAVEMENT (157,000 LBS)
 MODEL MD-90-30



NOTES: • H44.5 x 16.5-21, 26 PR TIRES
 • TIRE PRESSURE CONSTRAINT AT 193 PSI (13.6 KG/CM²)

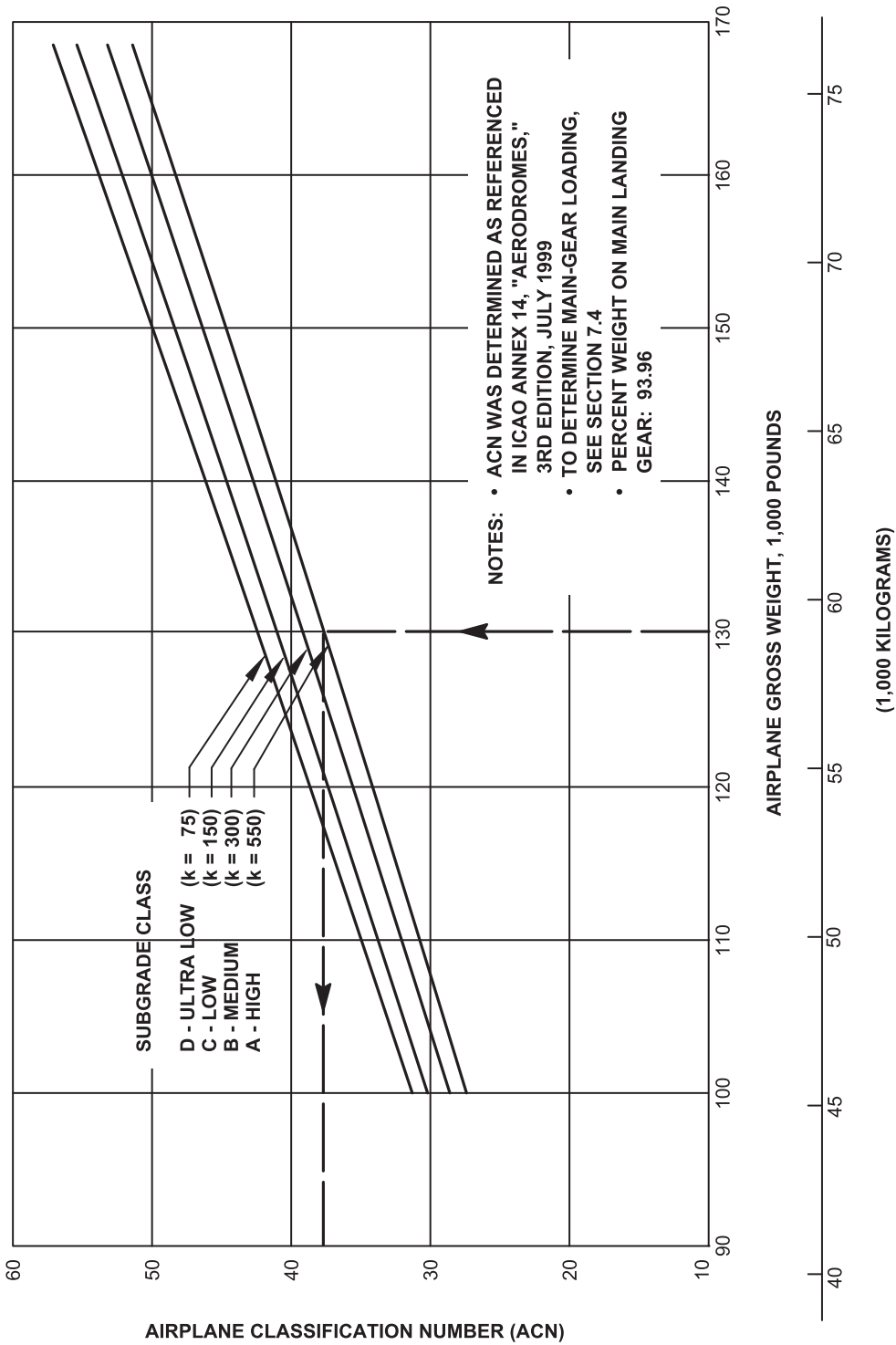

**7.9.4 AIRCRAFT CLASSIFICATION NUMBER -- RIGID PAVEMENT (168,500 LBS)
 MODEL MD-90-30ER**



7.9.5 Development of ACN Charts

The ACN charts for flexible and rigid pavements were developed by methods referenced in ICAO Annex 14, "Aerodromes," 3rd Edition, July 1999. The procedures used to develop these charts are also described below.

The following procedure is used to develop the flexible-pavement ACN charts such as that shown in Section 7.9.1:

1. Determine the percentage of weight on the main gear to be used below in Steps 2, 3, and 4, below. The maximum aft center-of-gravity position yields the critical loading on the critical gear (see Section 7.4). This center-of-gravity position is used to determine main gear loads at all gross weights of the model being considered.
2. Establish a flexible-pavement requirements chart using the S-77-1 design method, such as shown on the right side of Section 7.9.6. Use standard subgrade strengths of CBR 3, 6, 10, and 15 percent and 10,000 coverages. This chart provides the same thickness values as those of Section 7.5.1, but is presented here in a different format.
3. Determine reference thickness values from the pavement requirements chart of Step 2 for each standard subgrade strength and gear loading.
4. Enter the reference thickness values into the ACN flexible-pavement conversion chart shown on the left side of Figure 7.9.6 to determine ACN. This chart was developed using the S-77-1 design method with a single tire inflated to 1.25 MPa (181 psi) pressure and 10,000 coverages. The ACN is two times the derived single-wheel load expressed in thousands of kilograms. These values of ACN are then plotted as functions of aircraft gross weight, as shown in Section 7.9.1.

The following procedure is used to develop the rigid-pavement ACN charts such as that shown in Section 7.9.2:

1. Determine the percentage of weight on the main gear to be used in Steps 2, 3, and 4, below. The maximum aft center-of-gravity position yields the critical loading on the critical gear (see Section 7.4). This center-of-gravity position is used to determine main gear loads at all gross weights of the model being considered.
2. Establish a rigid-pavement requirements chart using the PCA computer program PDILB, such as shown on the right side of Section 7.9.7. Use standard subgrade strengths of $k = 75, 150, 300, \text{ and } 550 \text{ lb/in.}^3$ (nominal values for $k = 20, 40, 80, \text{ and } 15 \text{ MN/M}^3$). This chart provides the same thickness values as those of Section 7.7.1.



- 3 Determine reference thickness values from the pavement requirements chart of Step 2 for each standard subgrade strength and gear loading at 400 psi working stress (nominal value for 2.75 MPa working stress).
4. Enter the reference thickness values into the ACN rigid-pavement conversion chart shown on the left side of Section 7.9.7 to determine ACN. This chart was developed using the PCA computer program PDILB with a single tire inflated to 1.25 MPa (181 psi) pressure and a working stress of 2.75 MPa (400 psi.) The ACN is two times the derived single-wheel load expressed in thousands of kilograms. These values of ACN were plotted as functions of aircraft gross weight, as already shown in Section 7.9.2.



ALLOWABLE WORKING STRESS (PSI)

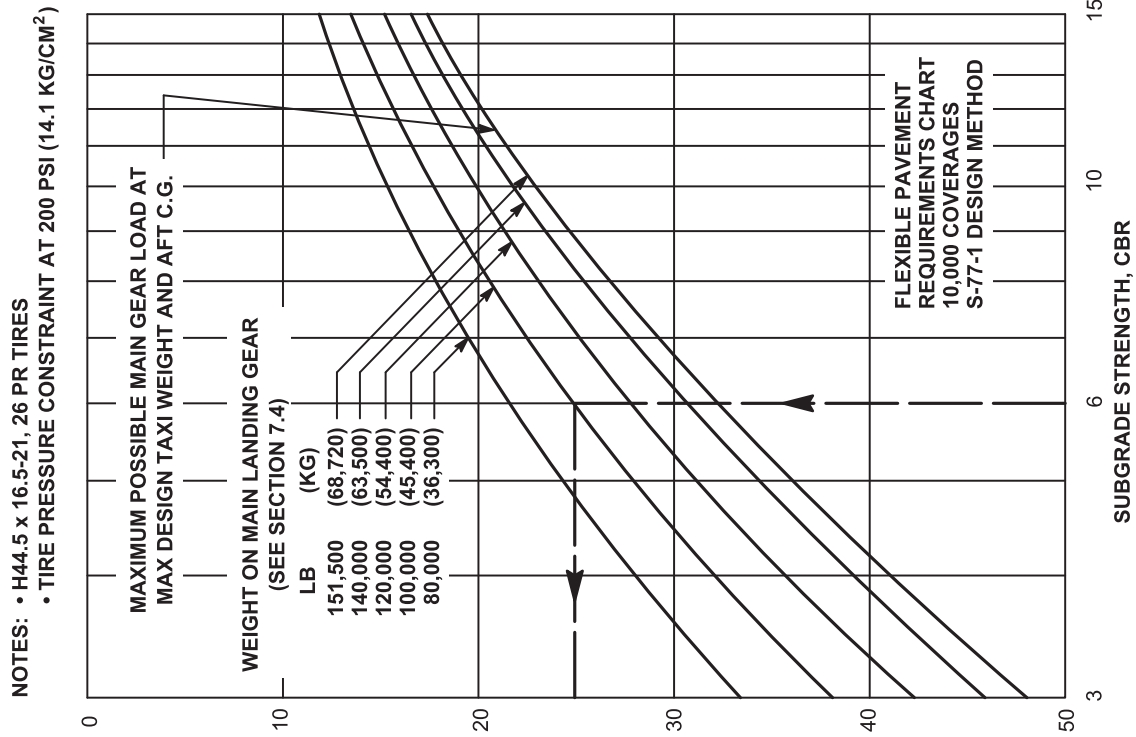

REFERENCE THICKNESS, INCHES

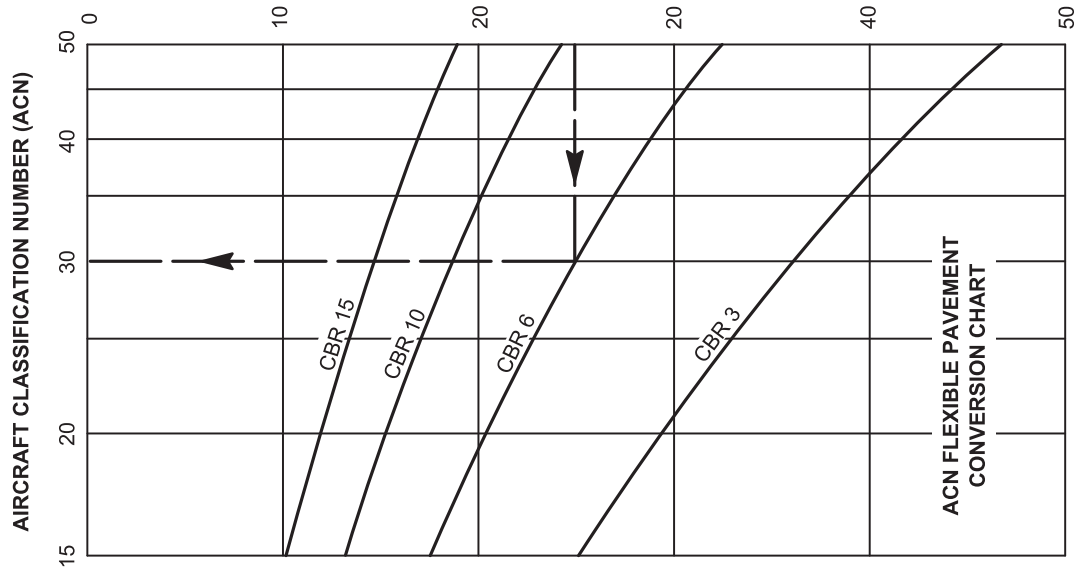

7.9.6 DEVELOPMENT OF AIRCRAFT CLASSIFICATION NUMBER (ACN) - FLEXIBLE PAVEMENT MODEL MD-90-30



ALLOWABLE WORKING STRESS (PSI)

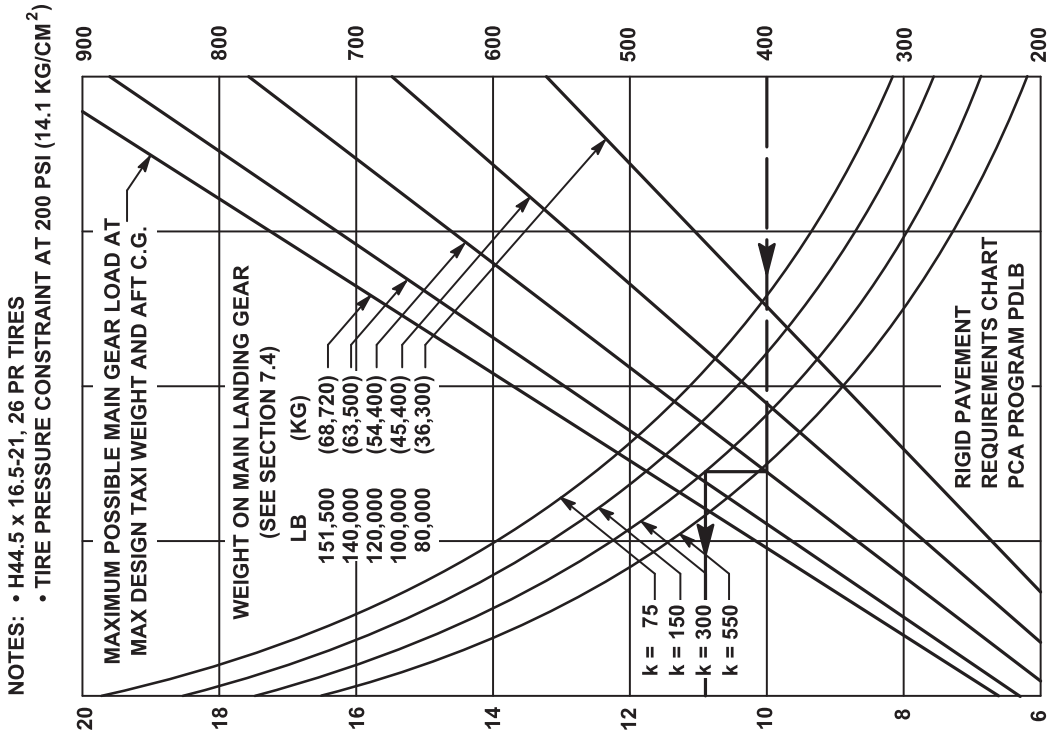

REFERENCE THICKNESS, INCHES

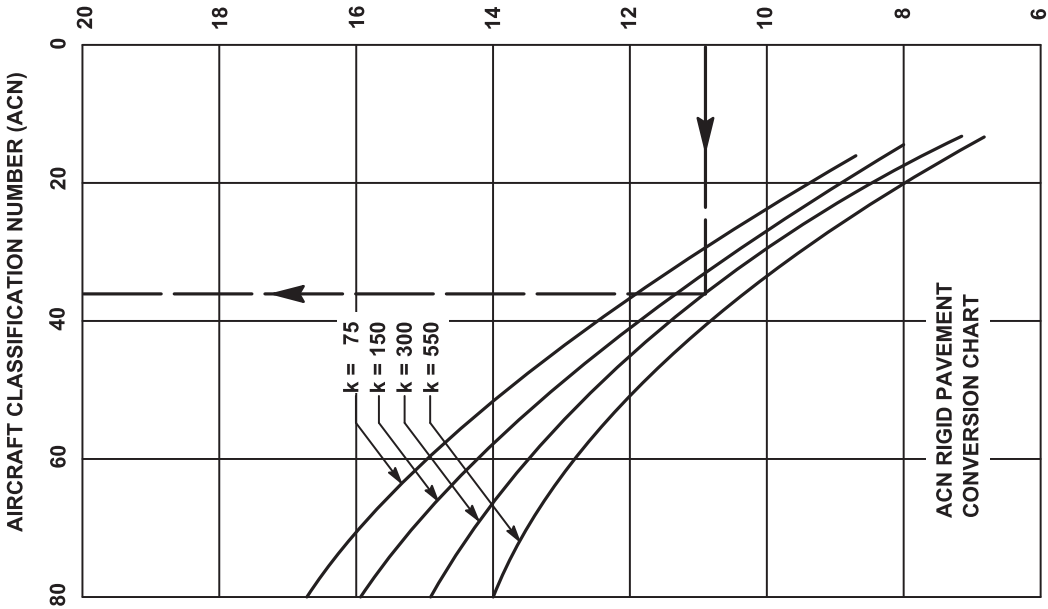

7.9.7 DEVELOPMENT OF AIRCRAFT CLASSIFICATION NUMBER (ACN) - RIGID PAVEMENT MODEL MD-90-30



8.0 POSSIBLE MD-90 DERIVATIVE AIRPLANES



This page intentionally left blank



8.0 POSSIBLE MD-90 DERIVATIVE AIRPLANES

No additional versions of the MD-90 are currently planned.



This page intentionally left blank



9.0 MD-90-30 SCALE DRAWINGS

OCTOBER 2002

MDC K9099

Not Subject to EAR or ITAR.
Copyright © 2023 Boeing. All Rights Reserved.



This page intentionally left blank

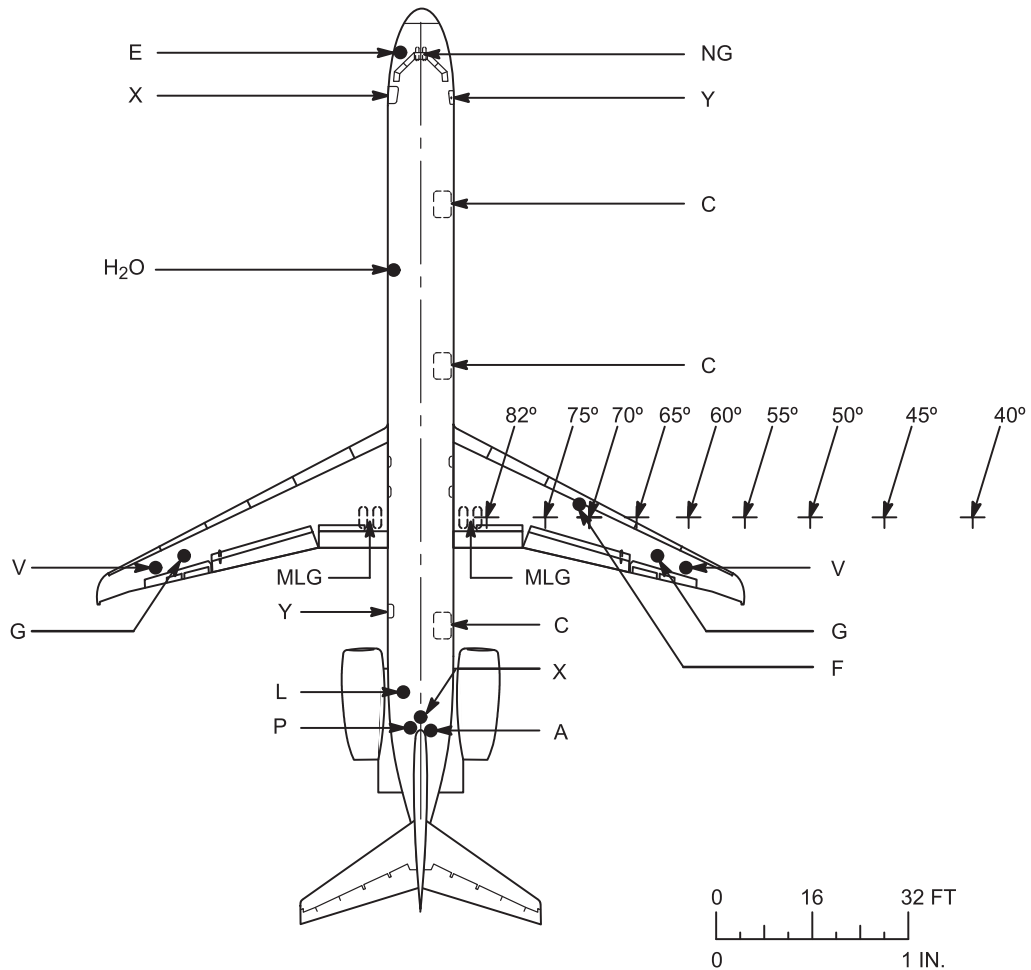

LEGEND

- | | | | |
|------------------|---------------------------|----|---|
| A | AIR CONDITIONING (1) | NG | NOSE GEAR |
| C | LOWER DECK CARGO DOOR (3) | P | PNEUMATIC (1) |
| E | ELECTRICAL (1) | V | FUEL VENT (2) |
| F | PRESSURE REFUELING (1) | X | PASSENGER DOOR (2) |
| G | GRAVITY REFUELING (2) | Y | SERVICE DOOR (2) |
| H ₂ O | POTABLE WATER (1) | + | TURNING RADIUS POINTS: |
| L | LAVATORY (1) | | 82 DEG, 75 DEG, 70 DEG, 65 DEG, 60 DEG, |
| MLG | MAIN LANDING GEAR | | 55 DEG, 50 DEG, 45 DEG, 40 DEG |

9.0 SCALE DRAWINGS

9.1 1 INCH = 32 FEET

MODEL MD-90-30

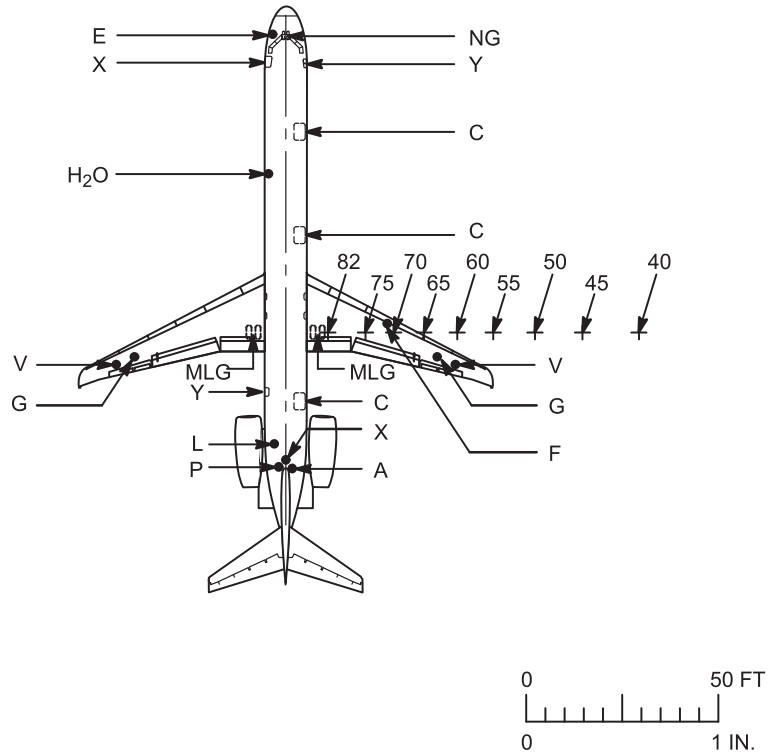

LEGEND

- | | | | |
|------------------|---------------------------|----|---|
| A | AIR CONDITIONING (1) | NG | NOSE GEAR |
| C | LOWER DECK CARGO DOOR (3) | P | PNEUMATIC (1) |
| E | ELECTRICAL (1) | V | FUEL VENT (2) |
| F | PRESSURE REFUELING (1) | X | PASSENGER DOOR (2) |
| G | GRAVITY REFUELING (2) | Y | SERVICE DOOR (2) |
| H ₂ O | POTABLE WATER (1) | + | TURNING RADIUS POINTS: |
| L | LAVATORY (1) | | 82 DEG, 75 DEG, 70 DEG, 65 DEG, 60 DEG, |
| MLG | MAIN LANDING GEAR | | 55 DEG, 50 DEG, 45 DEG, 40 DEG |

9.0 SCALE DRAWINGS

9.2 1 INCH = 50 FEET

MODEL MD-90-30

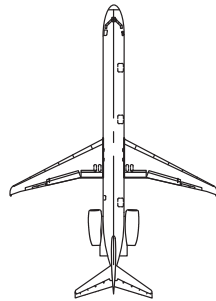

*SEE OTHER PAGES IN THIS SECTION FOR SERVICE POINT LOCATIONS.

9.0 SCALE DRAWINGS
9.3 1 INCH = 100 FEET
MODEL MD-90-30

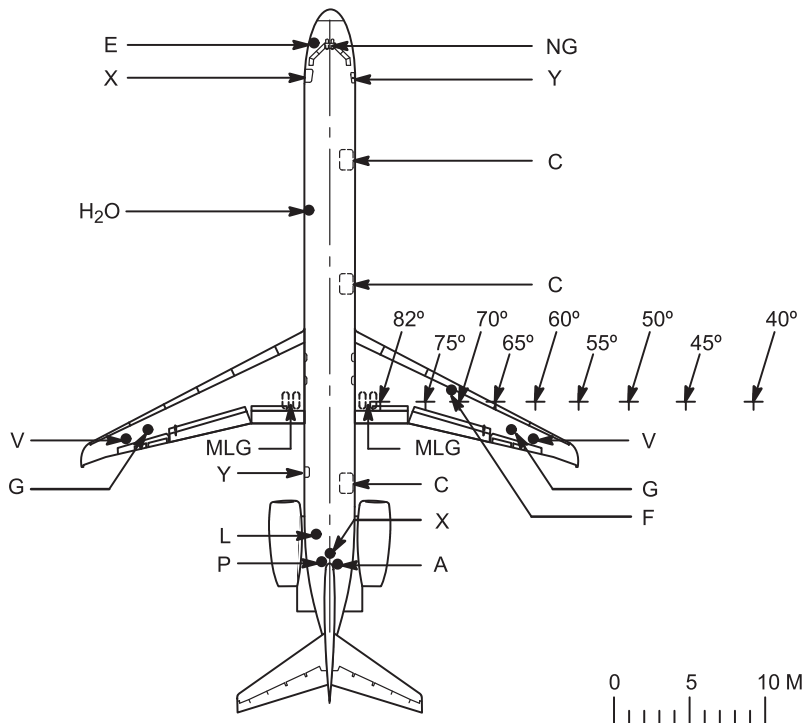

LEGEND

A	AIR CONDITIONING (1)	NG	NOSE GEAR
C	LOWER DECK CARGO DOOR (3)	P	PNEUMATIC (1)
E	ELECTRICAL (1)	V	FUEL VENT (2)
F	PRESSURE REFUELING (1)	X	PASSENGER DOOR (2)
G	GRAVITY REFUELING (2)	Y	SERVICE DOOR (2)
H ₂ O	POTABLE WATER (1)	+	TURNING RADIUS POINTS:
L	LAVATORY (1)		82 DEG, 75 DEG, 70 DEG, 65 DEG, 60 DEG,
MLG	MAIN LANDING GEAR		55 DEG, 50 DEG, 45 DEG, 40 DEG

9.0 SCALE DRAWINGS

9.4 1 TO 500

MODEL MD-90-30

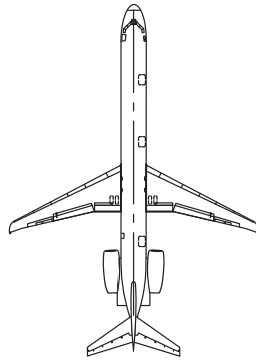

*SEE OTHER PAGES IN THIS SECTION FOR SERVICE POINT LOCATIONS.

9.0 SCALE DRAWINGS
9.5 1 TO 1000
MODEL MD-90-30



This page intentionally left blank