

737-200C/QC/F General Arrangement

StartupBoeing

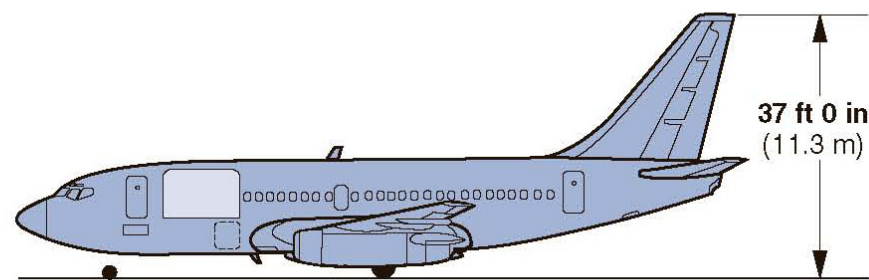
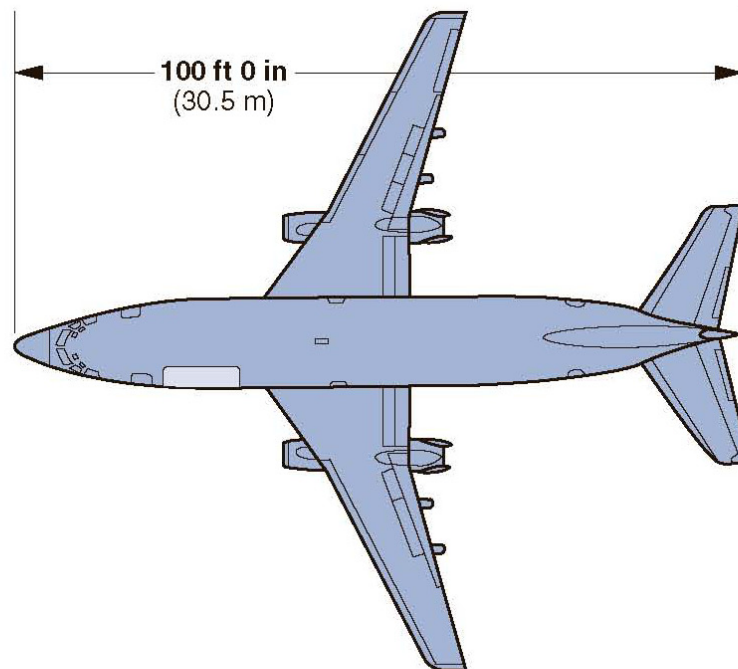
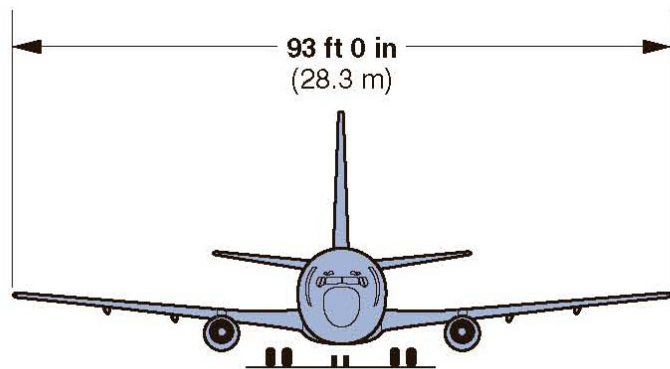

737-300QC/F General Arrangement

StartupBoeing

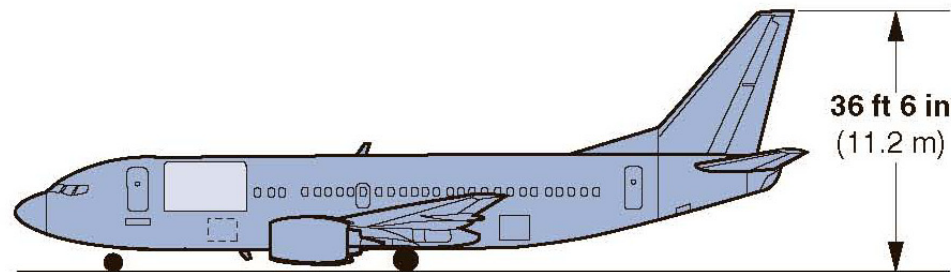
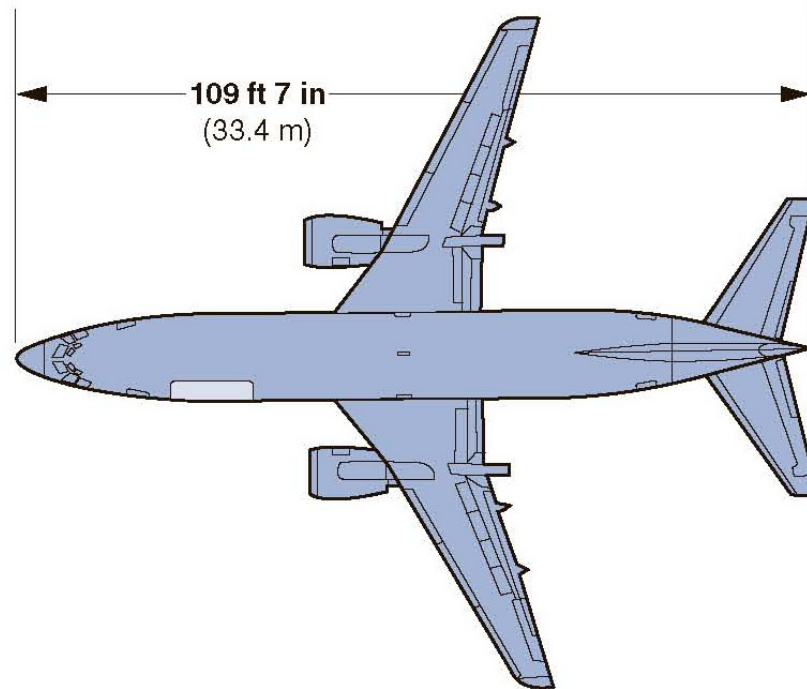
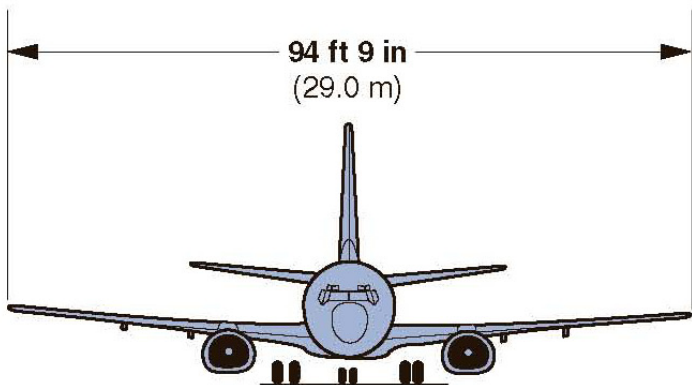

737-200C Advanced Servicing Arrangement

StartupBoeing

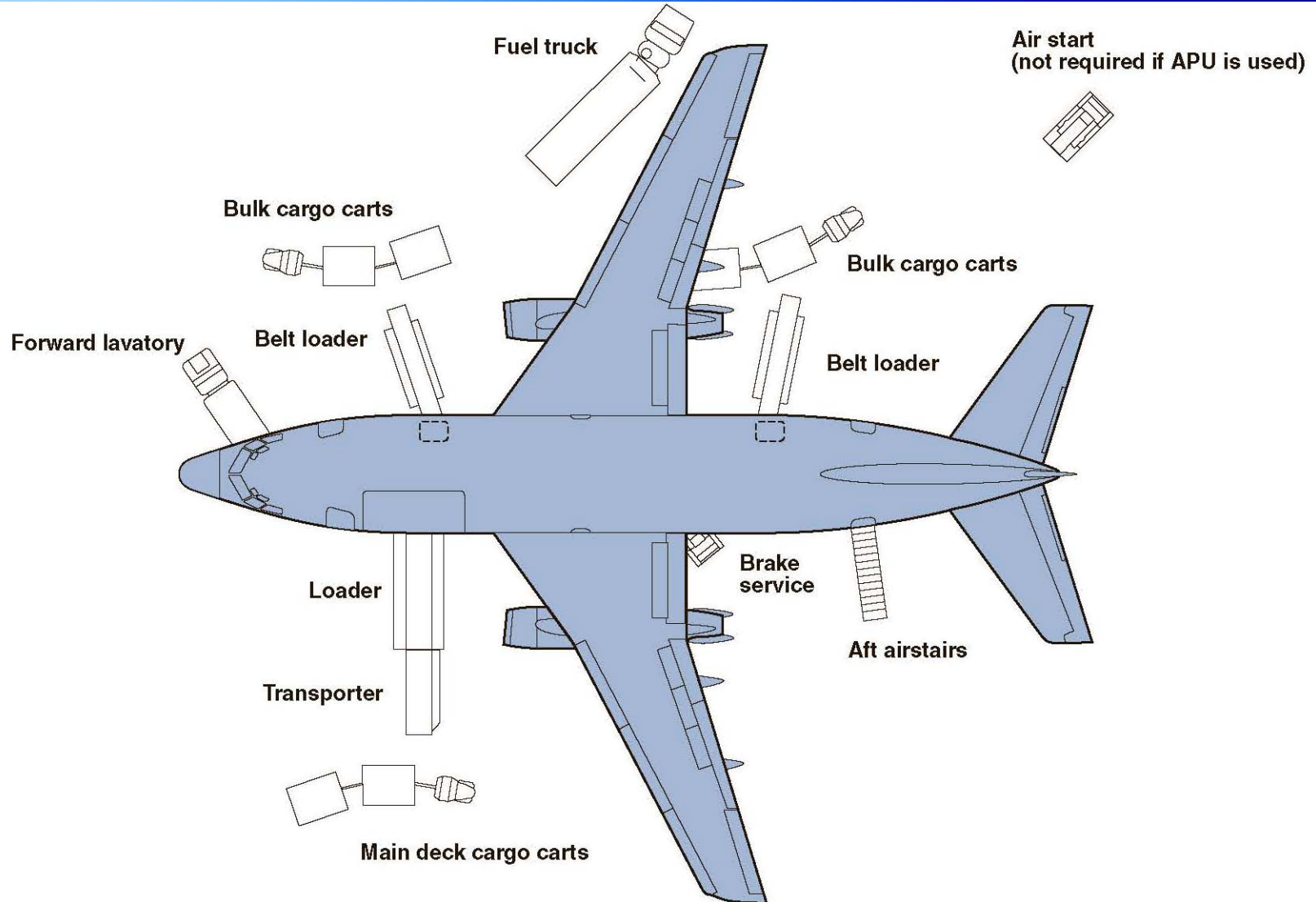

737-200/-300 Freighter Main Deck Arrangement

StartupBoeing

737-200C/QC/F

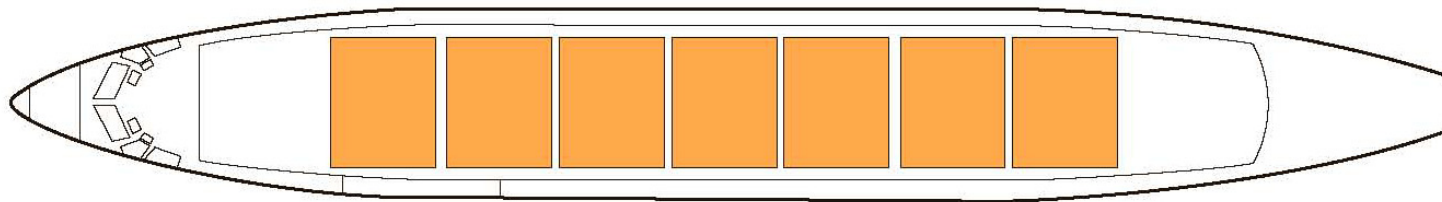

7 containers, 88 x 125 in (2.2 x 3.2 m)
Volume, 3,080 ft³ (87.2 m³); bulk volume, 875 ft³ (24.8 m³)

737-300F

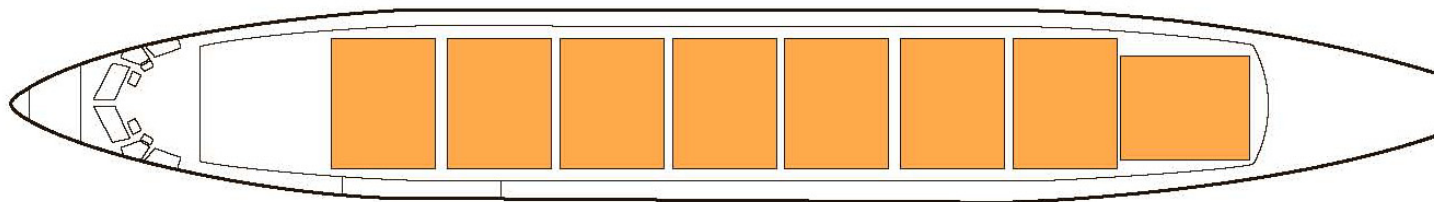

8 containers, 88 x 125 in (2.2 x 3.2 m)
Volume, 3,520 ft³ (99.7 m³); bulk volume, 1,068 ft³ (30.2 m³)

737-200/-300 Freighter Cross Section

StartupBoeing

737-200

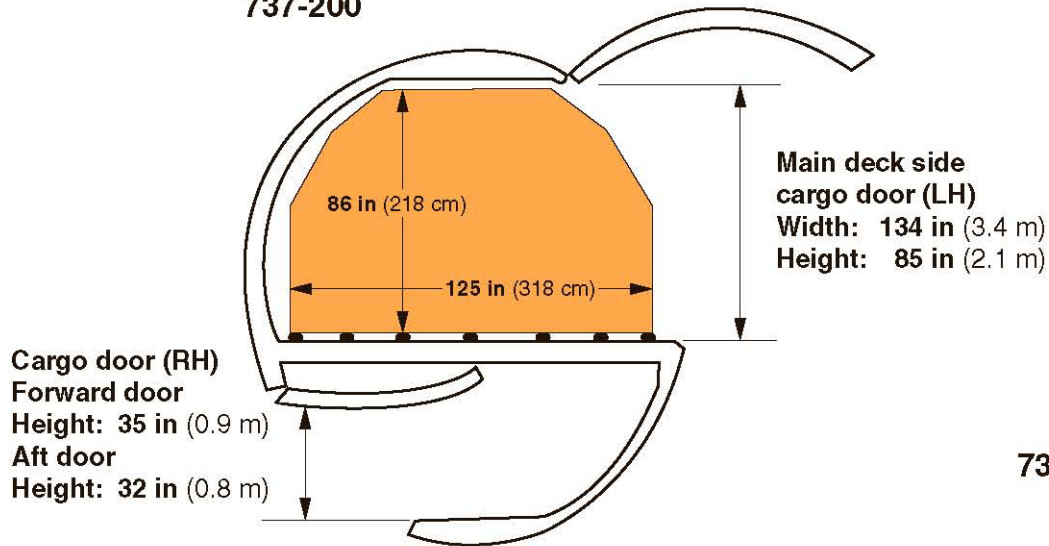

737-300

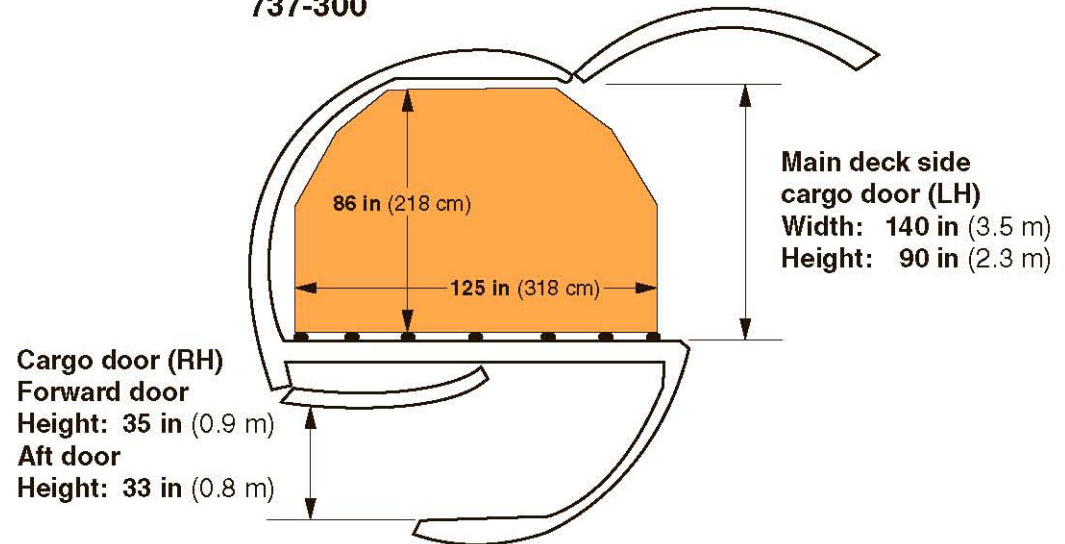

737-200/-300 Freighter Performance Summary

StartupBoeing

Pratt & Whitney JT8D-17A engines*
CFM56-3B engines

	737-200C (Advanced)		737-300SF	
Cargo capacity, ft³ (m³)				
Main deck, (7*/8) 88- x 125-in (2.2- x 3.2-m)				
pallets or containers	3,080	(87.2)	3,520	(99.7)
Lower hold bulk volume	875	(24.8)	1,068	(30.2)
Total cargo volume	3,955	(112.0)	4,588	(130.0)
Maximum gross weight, lb (kg)				
Takeoff	124,500	(56,470)	139,500	(63,276)
Landing	107,000	(48,530)	116,600	(52,889)
Zero fuel	99,000	(44,900)	109,600	(49,714)
Structural limit payload (MZFW – OEW)	38,175	(17,315)	43,500	(19,731)
Operating empty weight including tare**	62,442	(28,323)	67,948	(30,821)
Fuel capacity, U.S. gal (L)	5,160	(19,533)	5,310	(20,100)
Design range (MZFW payload), nmi (km)	1,210	(2,240)	1,635	(3,028)
Chapter 3 cumulative margin, EPNdB	+18.6		-14.4	

* 737-200 models

** Tare weights: 1,617 lb (733.5 kg) for the 737-200C (Advanced), 1,848 lb (838.2 kg) for the 737-300SF

737-200/-300 Freighter Payload-Range Capability

StartupBoeing

Pratt & Whitney JT8D-17A engines

CFM56-3B engines

