

# 747-100/-200 Freighter

StartupBoeing

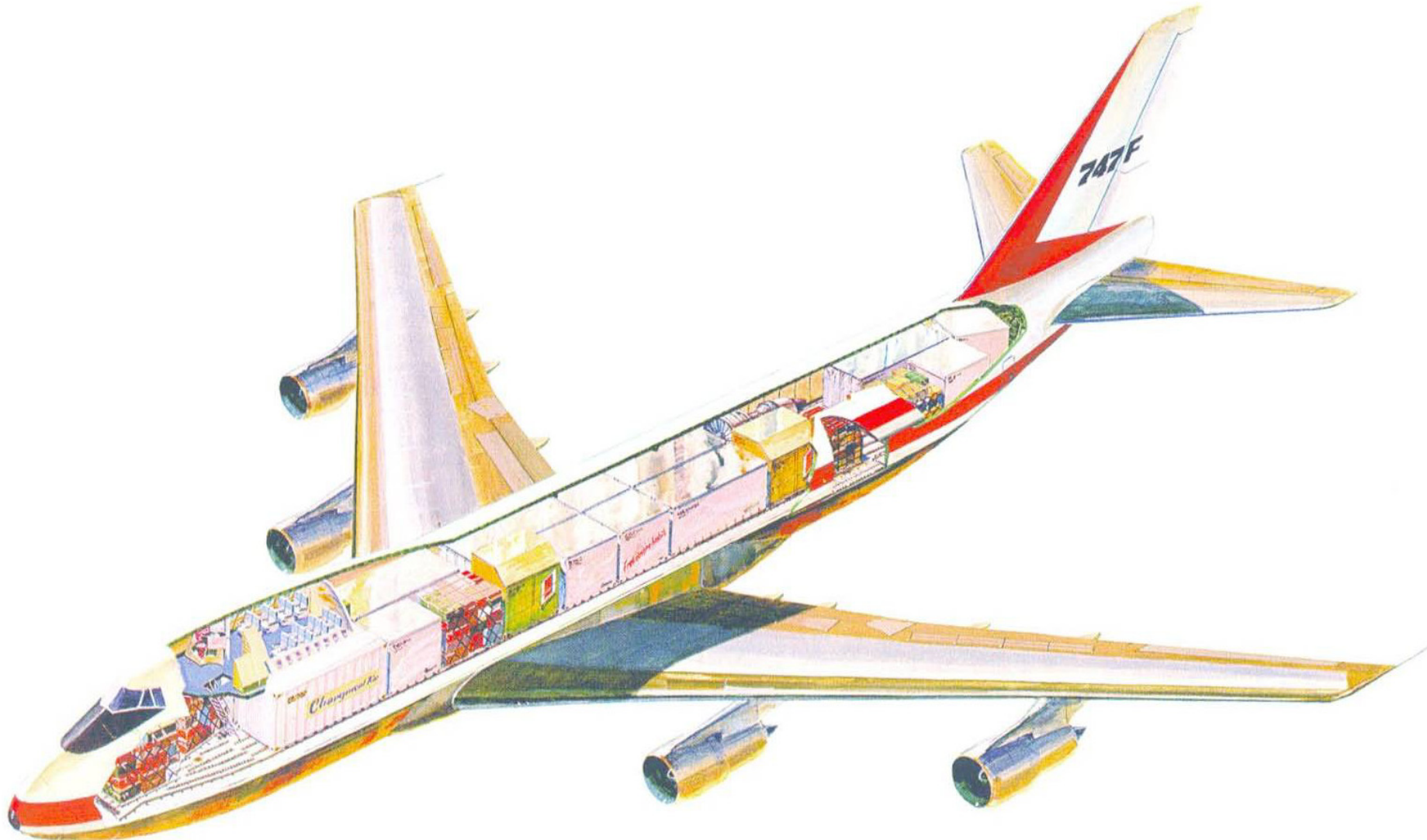

# 747-200 Freighter General Arrangement

StartupBoeing

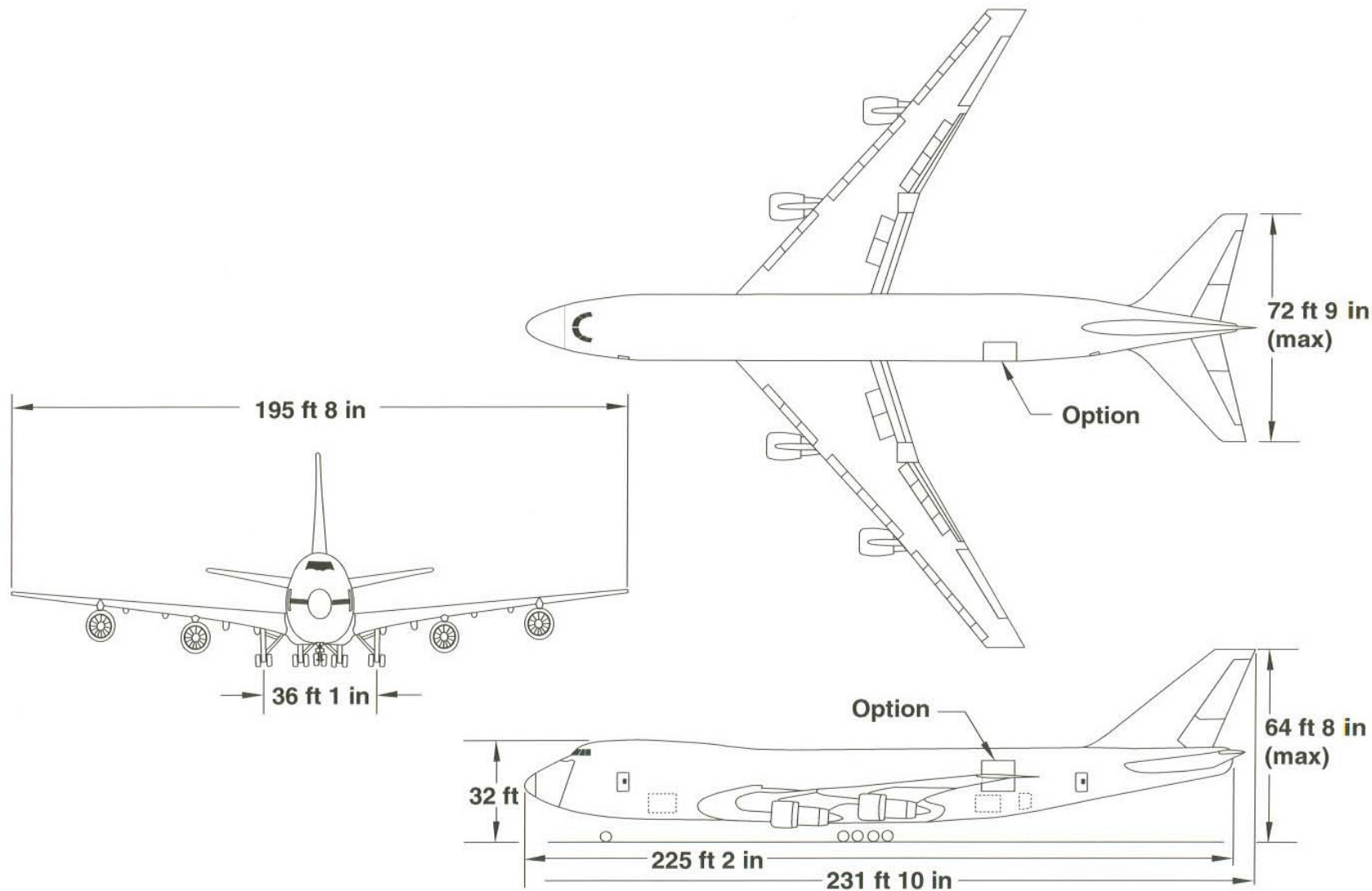

# 747-200 Freighter Crew Accommodations

StartupBoeing

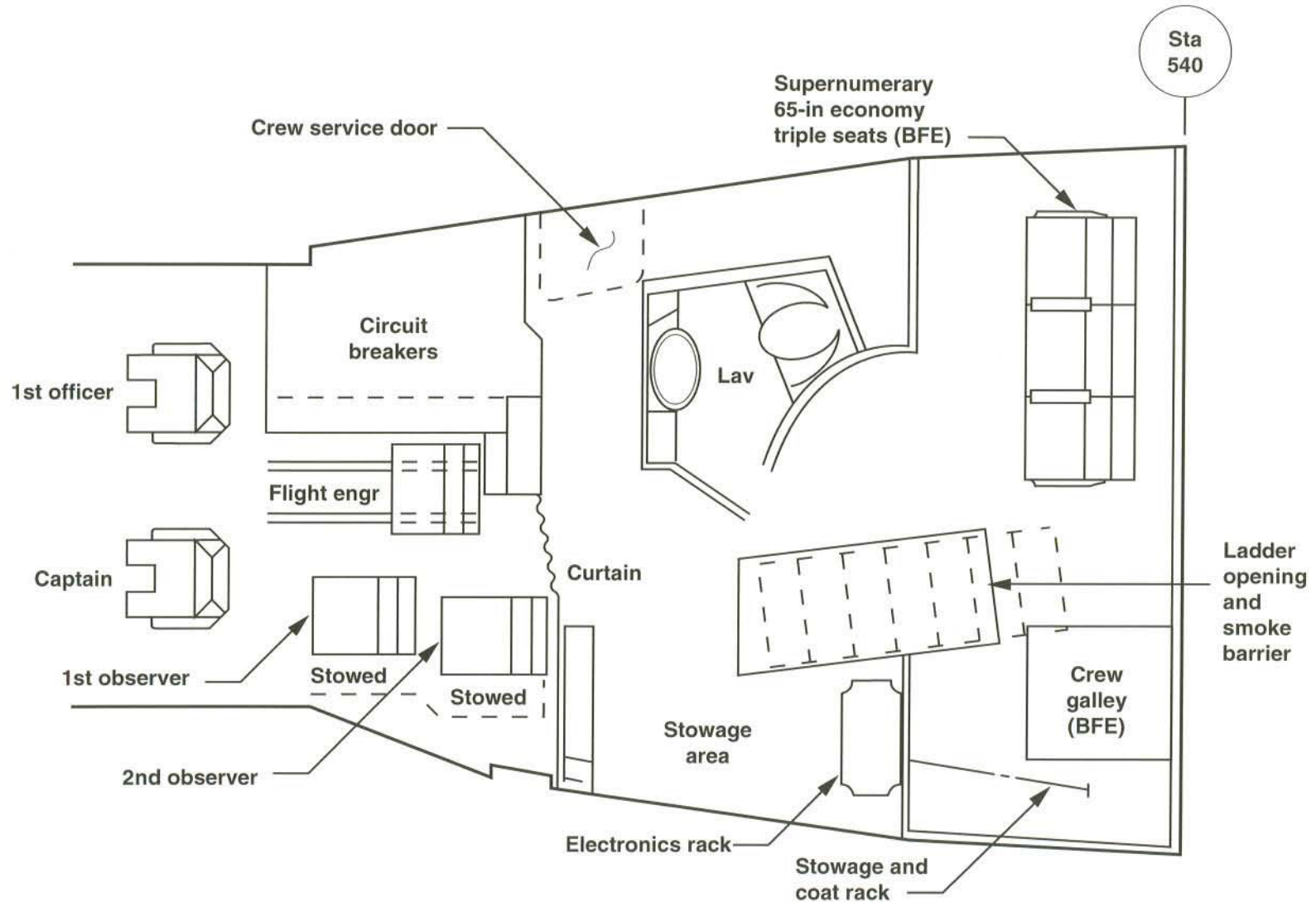

# 747-200 Freighter Basic Arrangement

StartupBoeing

## Flight deck

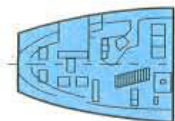

Crew + 3 supernumeraries

## Main deck

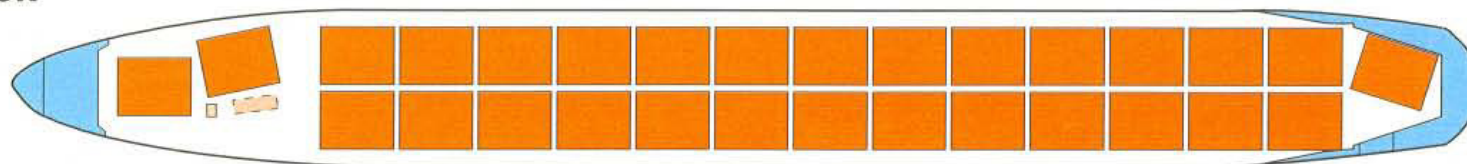

Twenty-nine 96- x 125-in pallet positions

## Lower hold

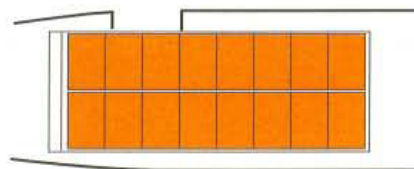

30 LD-1 containers

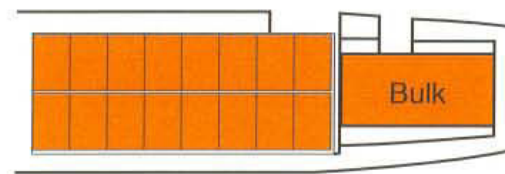

800 ft<sup>3</sup> bulk

# 747-200 Freighter Main Deck Arrangements

StartupBoeing

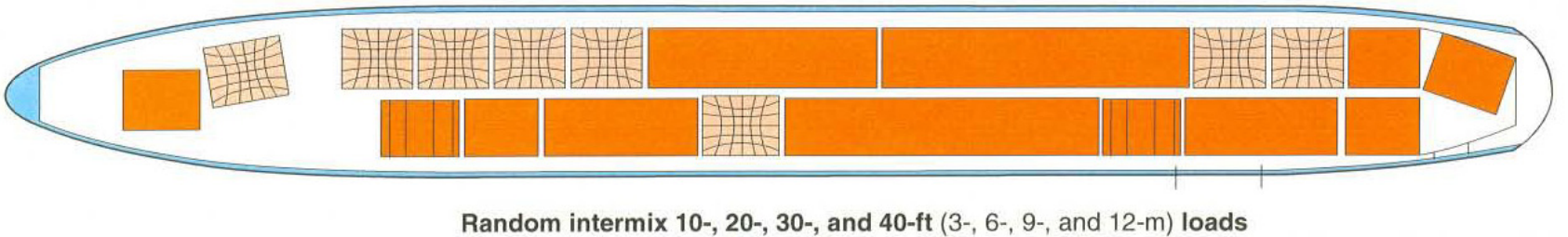
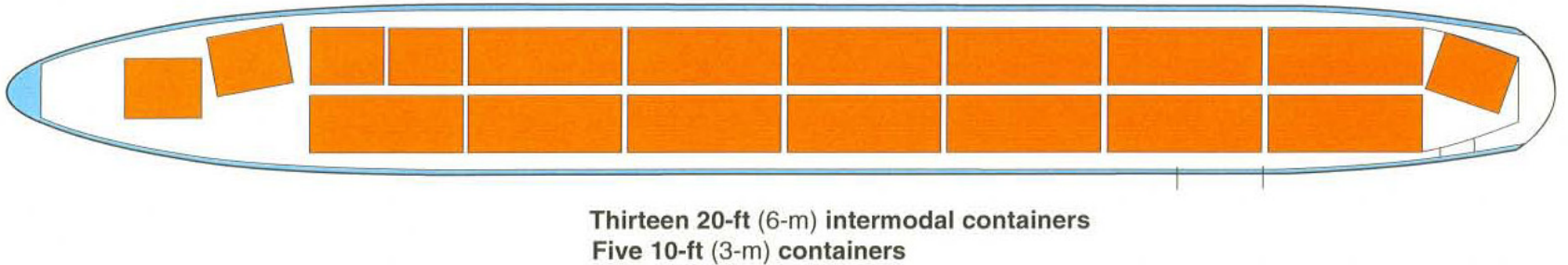
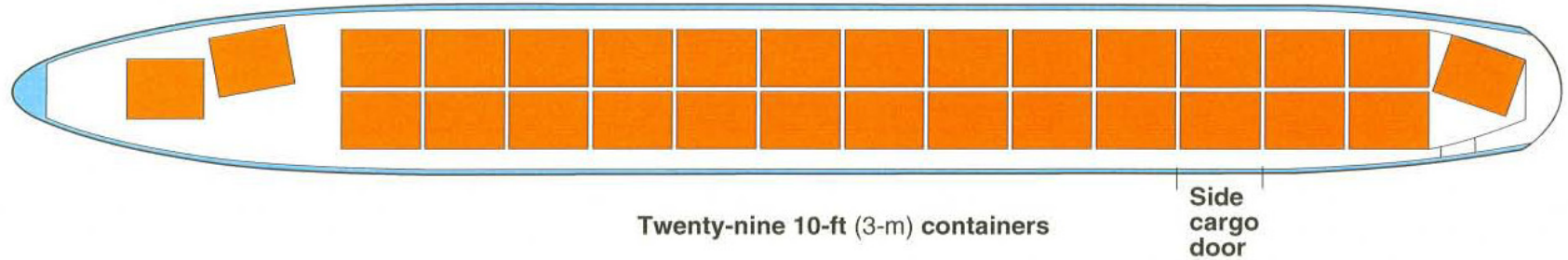

# 747 Freighter Auto Transport

StartupBoeing

## *Cadillac Allanté Airbridge*

56 cars total

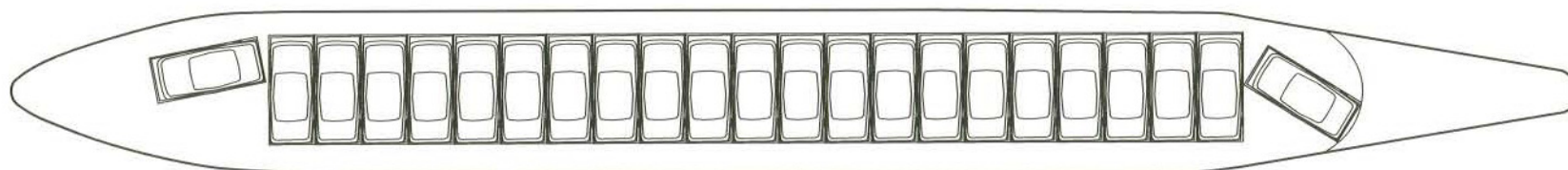
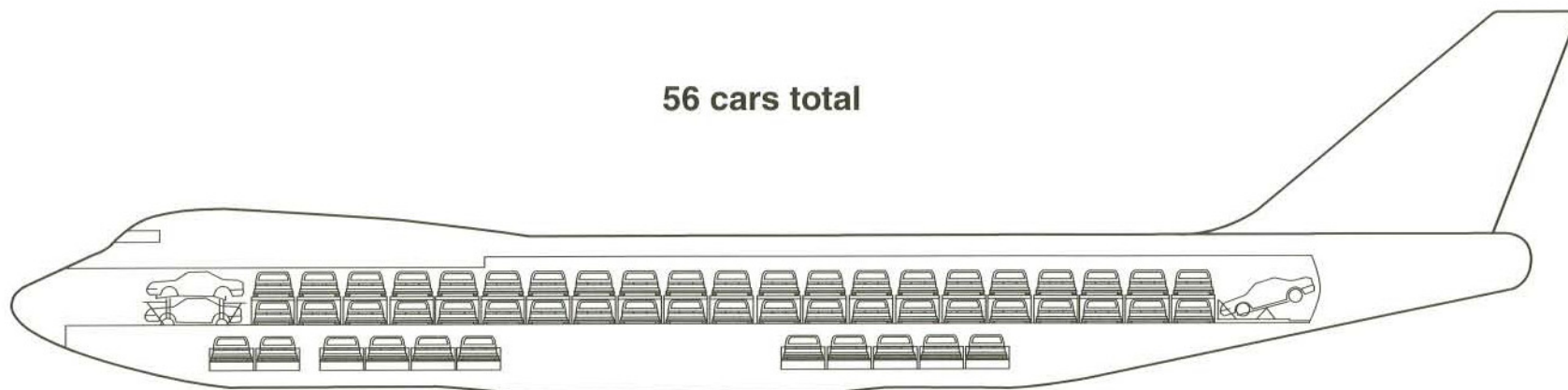

45 cars on main deck  
11 cars in lower hold

# 747-200 Freighter Car Transport

StartupBoeing



# 747-200 Freighter Floor Strength Comparison

StartupBoeing

## *Production 747-200F Versus 747-100/-200SF*

Maximum load, lb per  
96- x 125-in pallet position

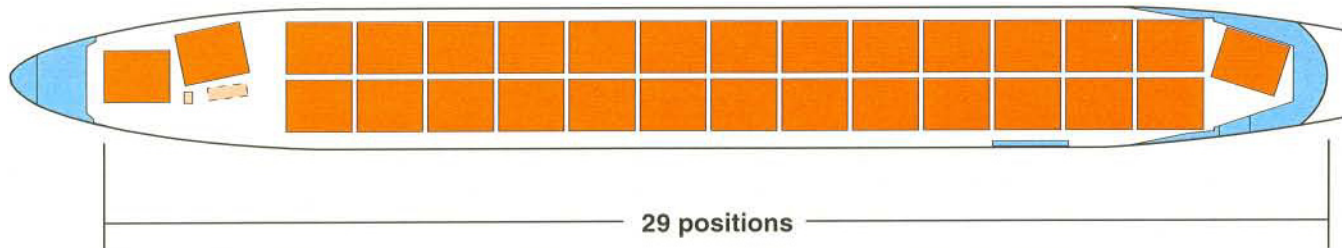

747-200F (ref) 29 positions	10,600		15,000	10,600		4,500	
Special Freighter 29 positions	6,000	9,400	15,000	9,400	10,600	6,900	4,500

Side door area



# 747 Freighter Cargo Weight Capability

StartupBoeing

## 747-200 Freighter

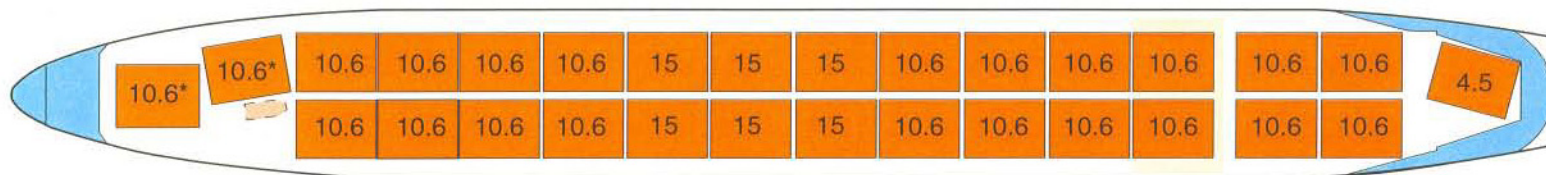

- Weight in thousands of pounds
- 96- x 125-inch pallets
- All weights shown include tare weight of pallets/containers

\* Limited by cargo restraints to 10,000 lb

# 747-200 Freighter Arrangement

StartupBoeing

## *All-Pallet Models*

### Flight deck

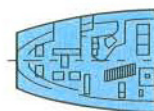

Crew + 3 supernumeraries

### Main deck

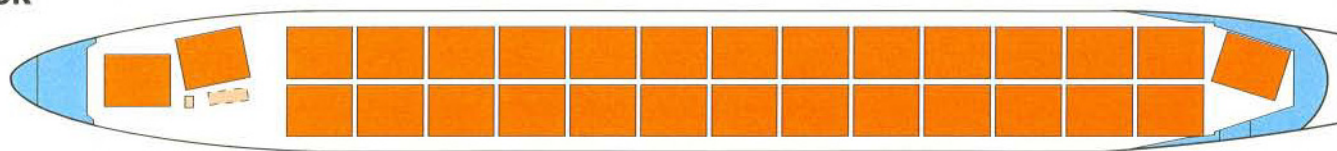

Twenty-nine 96- x 125-in pallet positions

### Lower hold

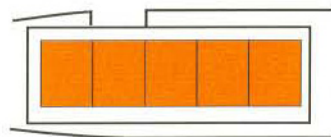

Nine 96- x 125-in pallets

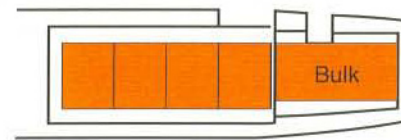

800 ft<sup>3</sup> bulk

# 747 Freighter Lower Hold Arrangements

StartupBoeing

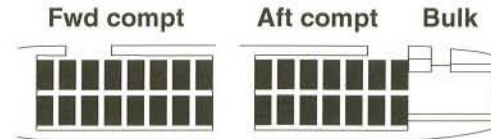
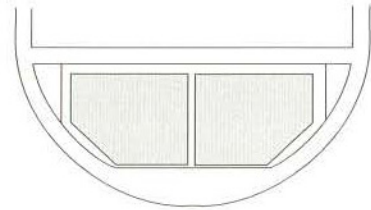

Thirty half-width containers

	Units	Volume, ft <sup>3</sup>	
		LD-1	LD-3
Lower hold Bulk cargo		5,250 800	4,740 800
<b>Total capacity</b>		<b>6,050</b>	<b>5,540</b>

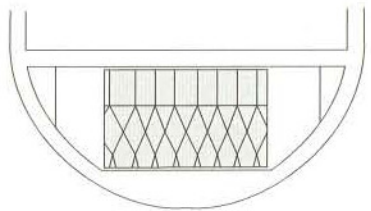

Nine 96- x 125-in pallets, 64 in high\*

	Units	Volume, ft <sup>3</sup>
Lower hold Bulk cargo		3,735 800
<b>Total capacity</b>		<b>4,535</b>

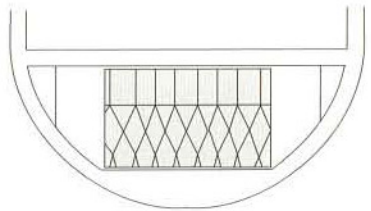

Nine 88- x 125-in pallets, 64 in. high\*  
Two 747 half-width containers

	Units	Volume, ft <sup>3</sup>
Lower hold	9	3,429
Bulk cargo	2	350 800
<b>Total capacity</b>		<b>4,579</b>

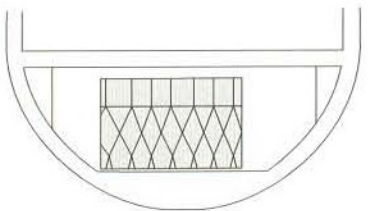

Nine 88- x 108-in pallets, 64 in high\*  
Two 747 half-width containers

	Units	Volume, ft <sup>3</sup>	
		Coml	Mil
Lower hold	9	2,943	2,880
Bulk cargo	2	350 800	350 800
<b>Total capacity</b>		<b>4,093</b>	<b>4,030</b>

\* Optional pallet hardware required

# 747 Freighter Lower Cargo Compartment Door

StartupBoeing

Rear view

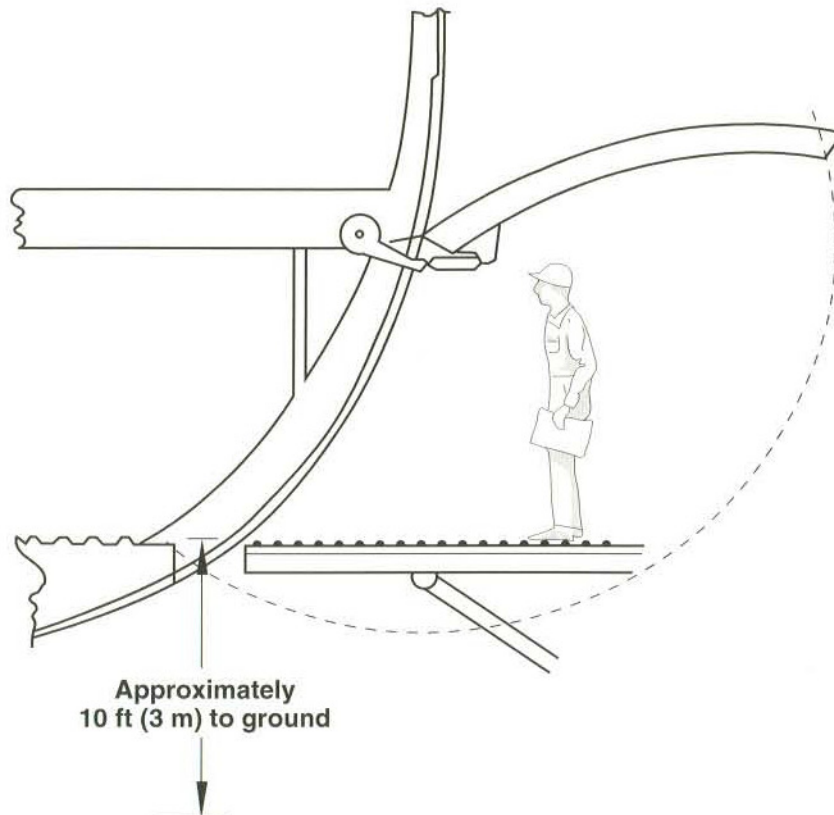

Right-hand side view

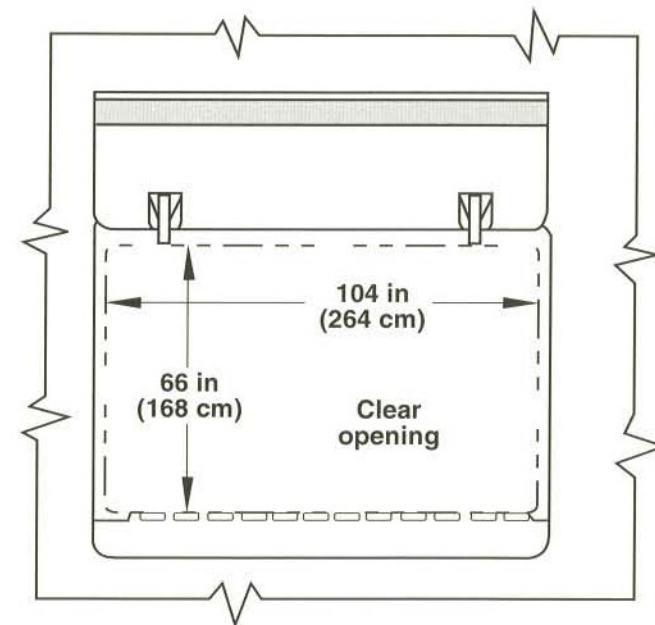

# 747 Freighter Lower Hold Capability

StartupBoeing

## Containers and Pallets

### Basic

3,500 lb MGW  
175 ft<sup>3</sup>  
(LD-1)

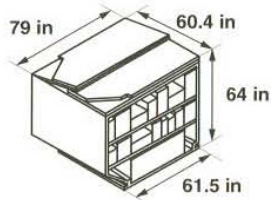
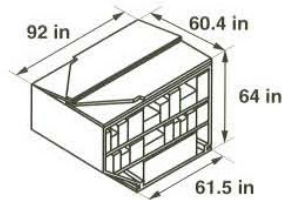

3,500 lb MGW  
159 ft<sup>3</sup>  
(LD-3)

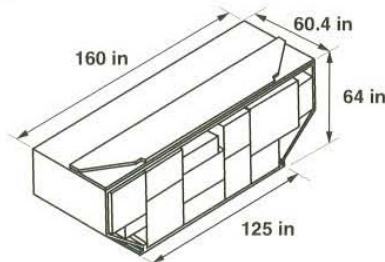

7,000 lb MGW\*  
322 ft<sup>3</sup>  
(LD-6)

### Optional (Additional hardware required)

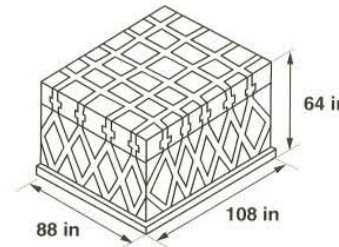

10,200 lb MGW\*  
320 ft<sup>3</sup> (military)  
327 ft<sup>3</sup> (commercial)

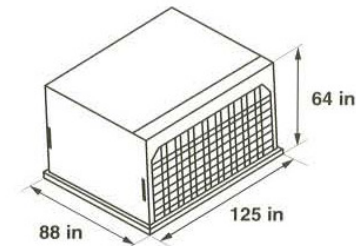

10,200 lb MGW\*  
381 ft<sup>3</sup>  
(LD-9)

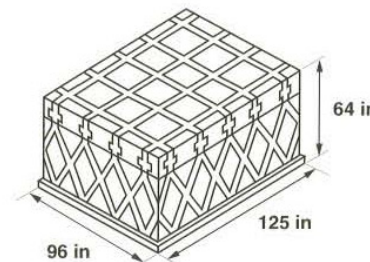

11,100 lb MGW\*  
407 ft<sup>3</sup>

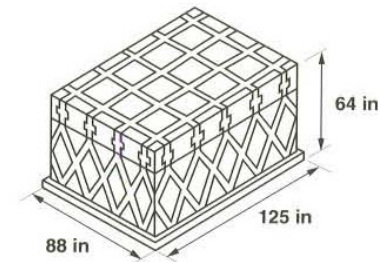

10,200 lb MGW\*  
372 ft<sup>3</sup>

\* Maximum gross weights (MGW) shown are based on lower hold running load capability (116 lb/in), subject to overall airframe structural limits

# 747-200 Freighter Cargo Door Arrangement

StartupBoeing

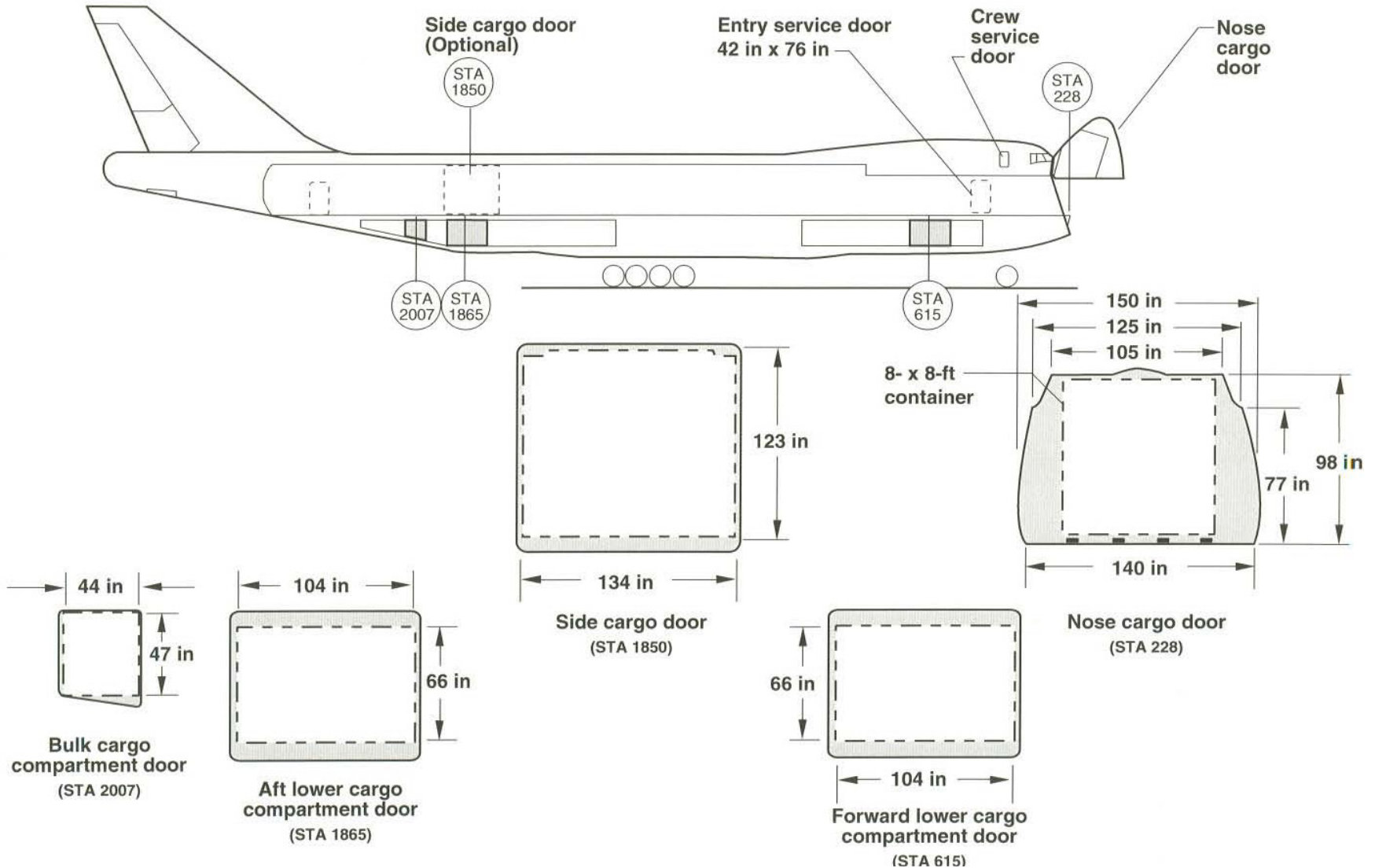

# 747-200 Freighter Nose Cargo Door

StartupBoeing

## Clearances

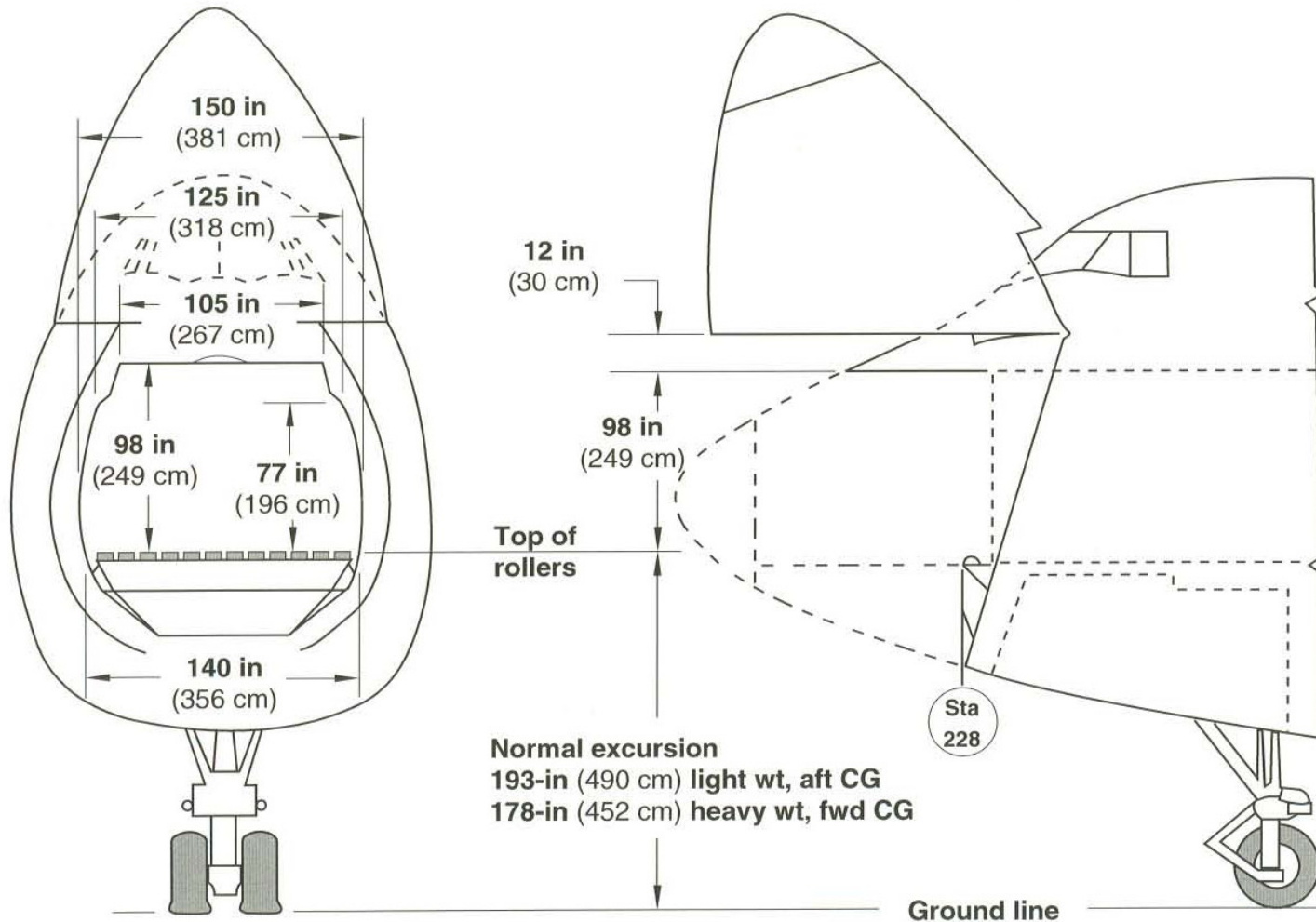

# 747 Side Cargo Door

StartupBoeing

## 747-200 Freighter

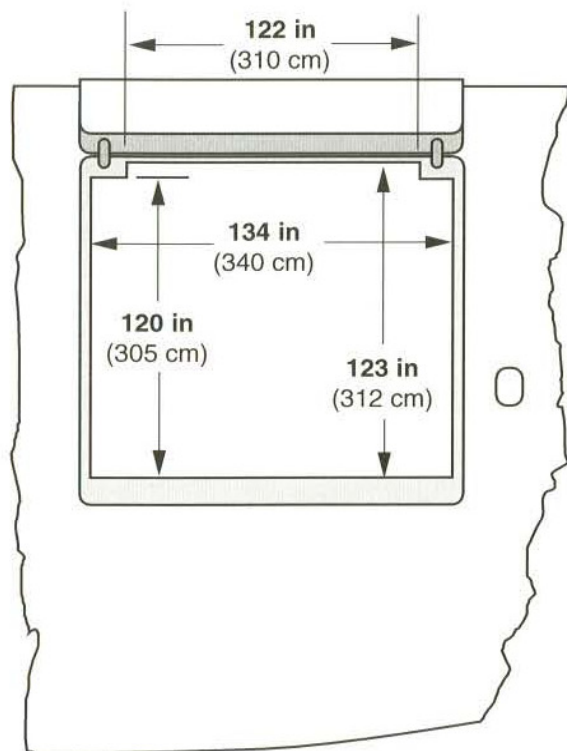

Side view

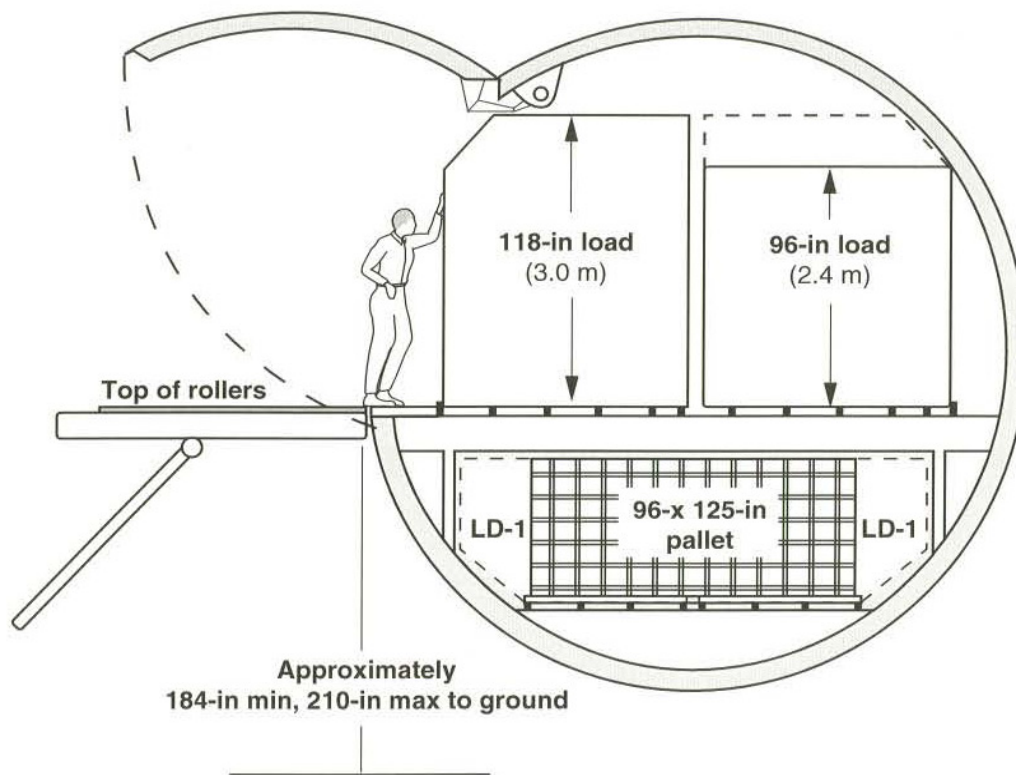

Rear view



# 747-200 Freighter Main Deck

StartupBoeing



# 747-200 Freighter Side Door

StartupBoeing



# 747 Freighter Performance Summary

StartupBoeing

		747-100SF	747-200SF	747-200F
<b>Engines</b>		<b>JT9D-7A</b>	<b>JT9D-7Q</b>	<b>JT9D-7R4G2</b>
<b>SLST to FR temperature</b>	<b>lb to °F</b>	<b>46,950 to 80</b>	<b>53,000 to 86</b>	<b>54,750 to 86</b>
<b>Max takeoff weight</b>	<b>lb</b>	<b>734,000</b>	<b>820,000</b>	<b>833,000</b>
<b>Max landing weight</b>	<b>lb</b>	<b>585,000</b>	<b>630,000</b>	<b>630,000</b>
<b>Max zero fuel weight</b>	<b>lb</b>	<b>545,000</b>	<b>590,000</b>	<b>590,000</b>
<b>Tare weight</b>	<b>lb</b>	<b>11,300</b>	<b>11,300</b>	<b>11,300</b>
<b>Operating empty weight</b>	<b>lb</b>	<b>334,800</b>	<b>351,100</b>	<b>347,200</b>
<b>Fuel capacity</b>	<b>U.S. gal</b>	<b>48,445</b>	<b>53,985</b>	<b>53,985</b>
<b>Structural payload</b>	<b>lb</b>	<b>210,200</b>	<b>238,900</b>	<b>242,800</b>
<b>Design range</b>	<b>nmi</b>	<b>2,656</b>	<b>3,050</b>	<b>3,615</b>
<b>Takeoff field length at 86°F</b>	<b>ft</b>	<b>10,100</b>	<b>10,550</b>	<b>10,900</b>
<b>Initial cruise altitude — MTOW</b>	<b>ft</b>	<b>32,300</b>	<b>33,400</b>	<b>32,400</b>
<b>Landing field length — MLW</b>	<b>ft</b>	<b>6,350</b>	<b>6,910</b>	<b>6,930</b>
<b>Approach speed — MLW</b>	<b>kt</b>	<b>144</b>	<b>152</b>	<b>152</b>
<b>Block fuel</b>				
<b>2,000-nmi mission</b>		<b>115,638</b>	<b>124,107</b>	<b>111,680</b>

- Typical mission rules
- Nominal performance level

# 747-200 Freighter Payload-Range Capability

StartupBoeing

## Typical Mission Rules

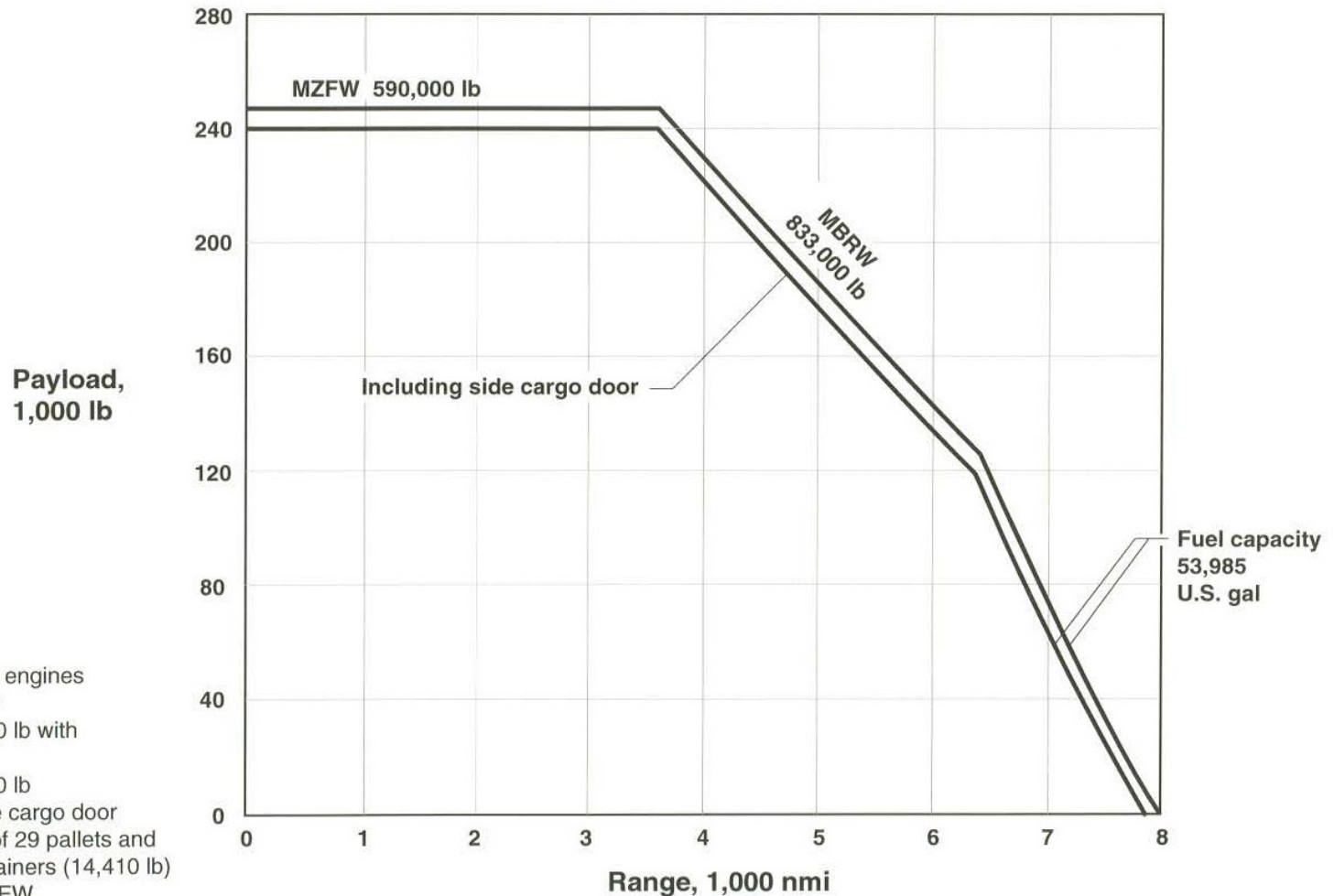

- JT9D-7R4G2 engines
- Standard day
- OEW 342,500 lb with nose door
- OEW 350,460 lb including side cargo door
- Tare weight of 29 pallets and 30 LD-1 containers (14,410 lb) included in OEW

# 747-200SF Payload-Range Capability

StartupBoeing

## Pratt & Whitney PW JT9D-7Q Engines

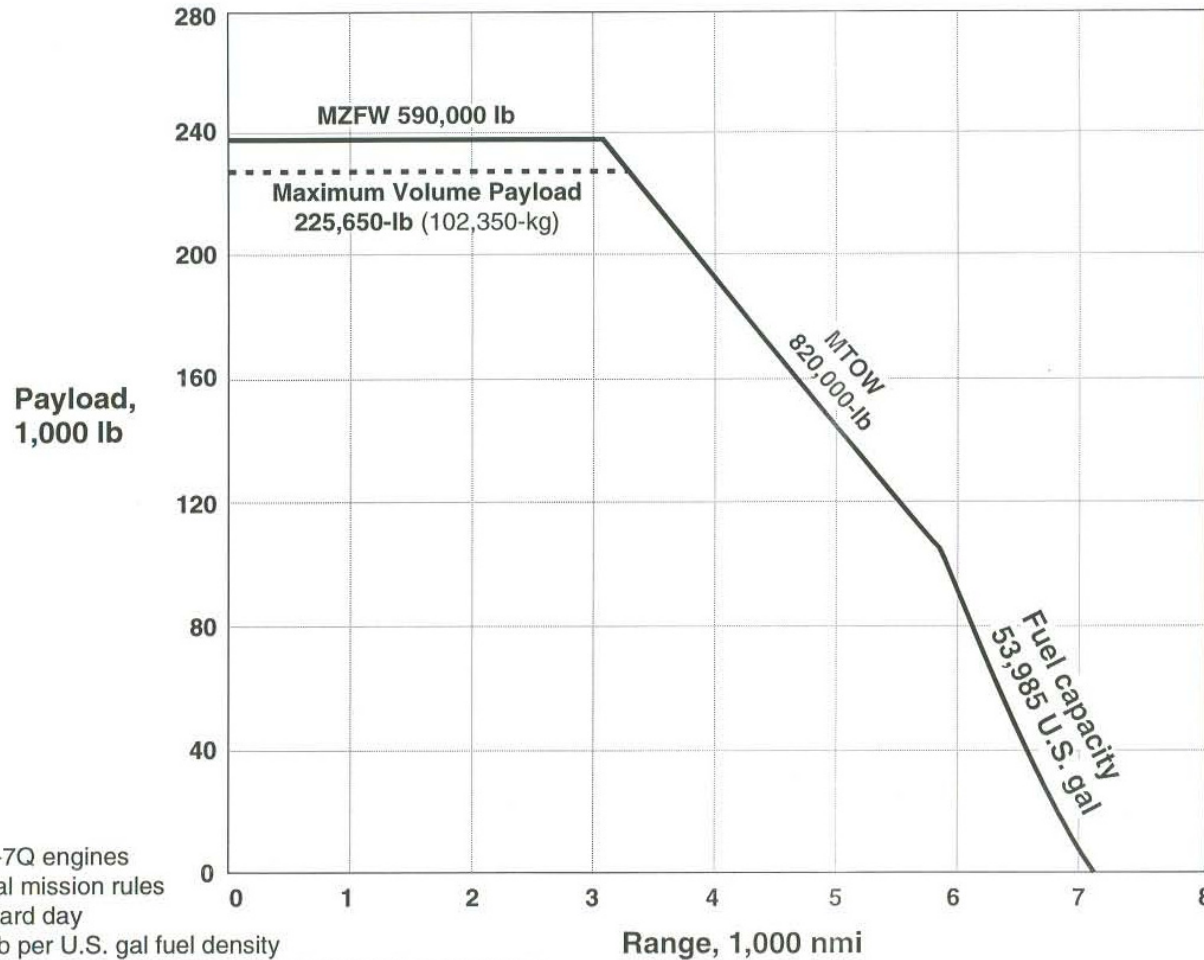

- JT9D-7Q engines
- Typical mission rules
- Standard day
- 6.75-lb per U.S. gal fuel density
- 3% SFC and 1% drag in-service deterioration assumed
- OEW 351,000 includes 11,310-lb tare

# 747-100SF Payload-Range Capability

StartupBoeing

## 747-100 Special Freighter

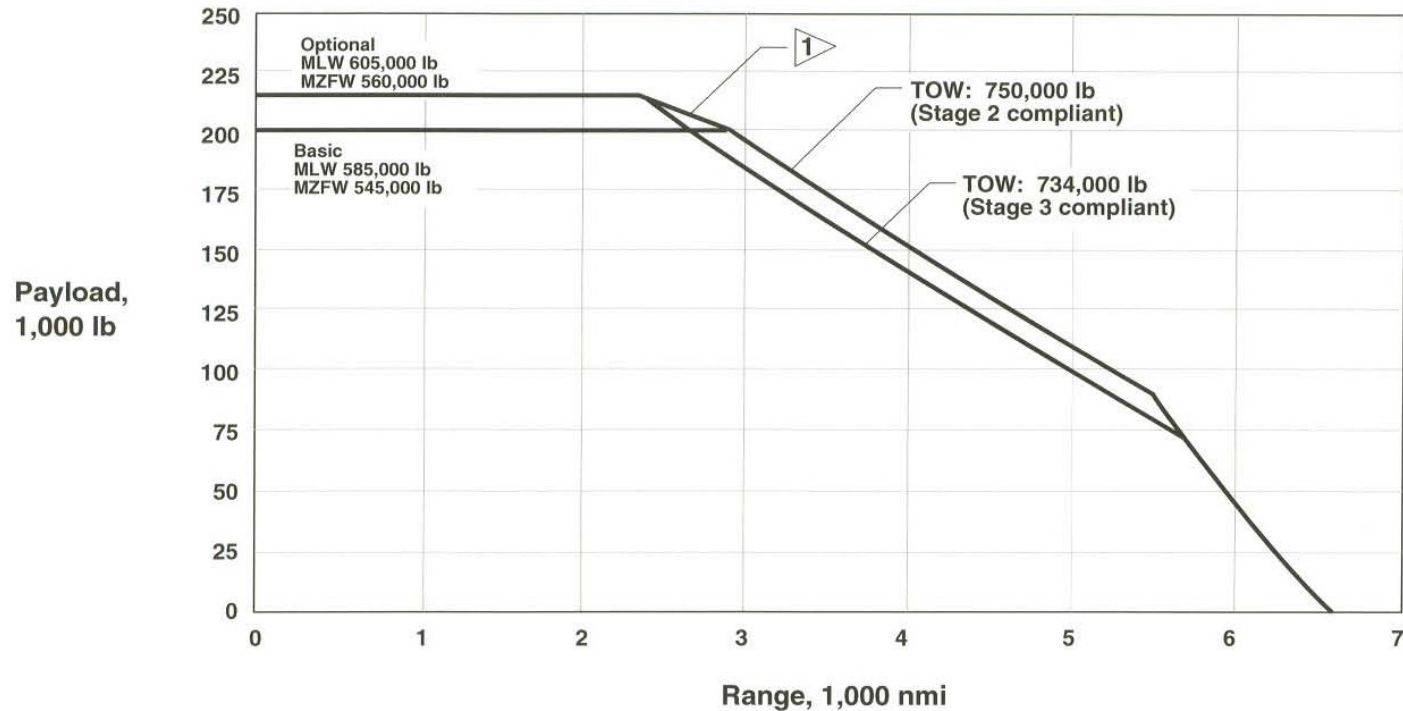

- JT9D-7A engines (-100 "CN" nacelle)
- Typical mission rules; 200 nmi alternate
- Standard day
- Long-range cruise
- OEW 345,600 lb (includes 3,890 lb of typical standard and operating items, plus 11,310 lb pallet tare)
- Fuel capacity 47,210 U.S. gallons
- 4% fuel burn in-service degradation

**1** A linear reduction in maximum takeoff weight from 750,000 to 734,000 lb is required as zero fuel weight increases from 545,000 to 560,000 lb

# 747 Freighter Mission Profile

StartupBoeing

## Typical Mission Rules

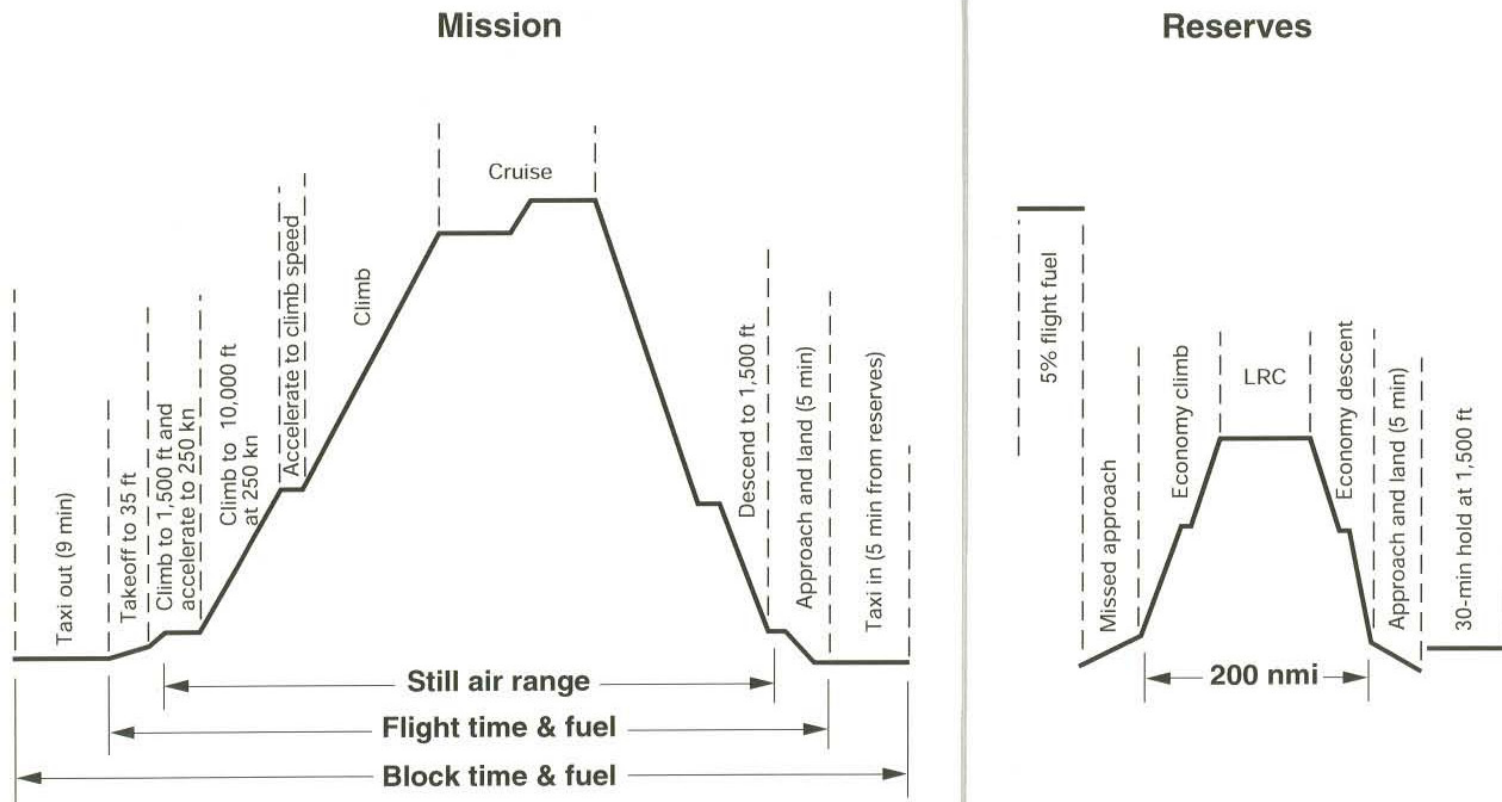

- Standard day
- Fuel density 6.7 lb/U.S. gal
- Nominal performance

# 747 Freighter Range Capability

StartupBoeing

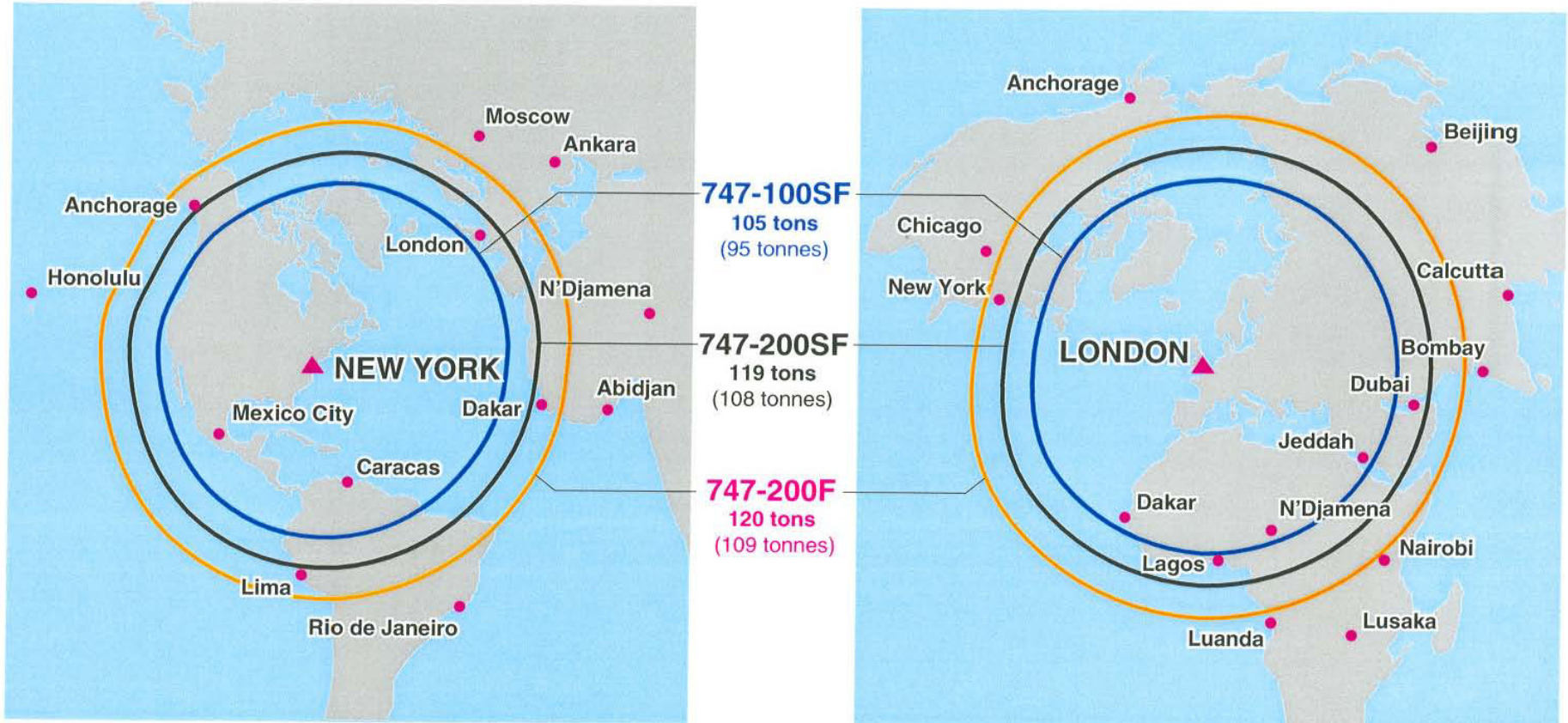

- 85% annual winds
- Unrestricted direct routing
- Maximum revenue payloads (excludes tare)



# 747 Freighter Range Capability

StartupBoeing

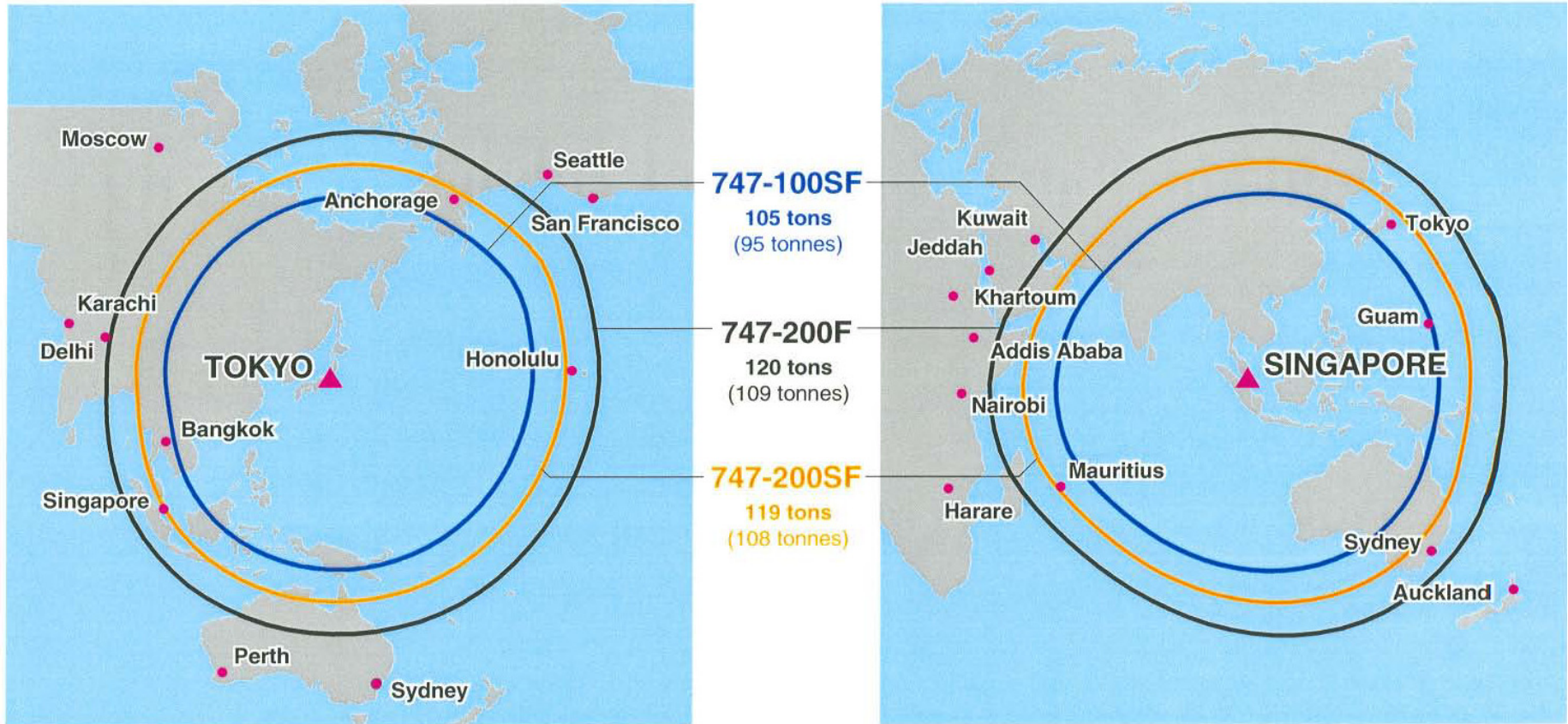

- 85% annual winds
- Unrestricted direct routing
- Maximum revenue payloads (excludes tare)