

DC-8 Freighters

General arrangement

StartupBoeing

DC-8-54/-55/-61/-71

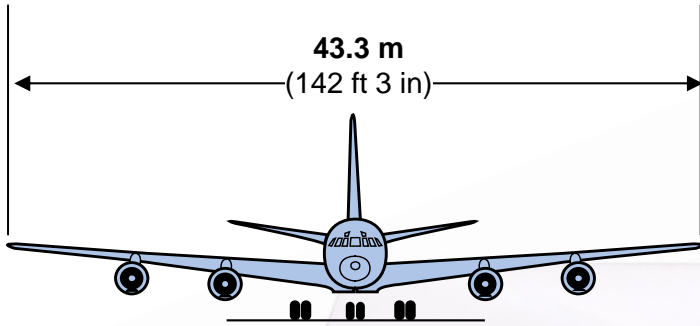

DC-8-62/-63/-72/-73

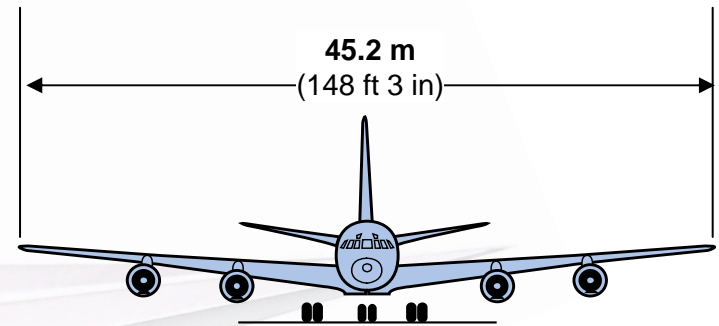

DC-8-61/-63/-71/-73

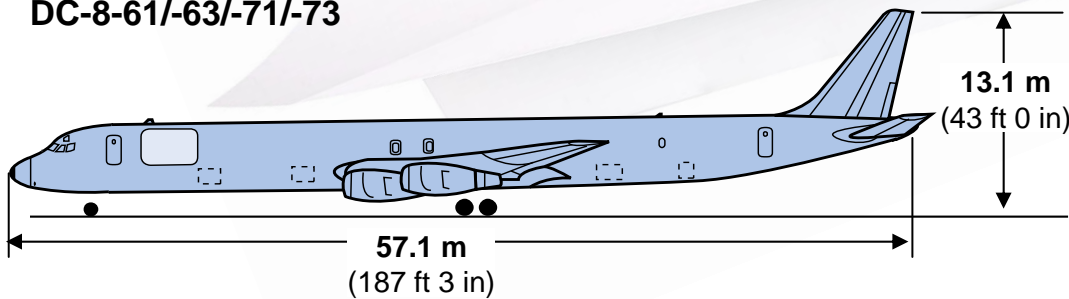

DC-8-62/-72

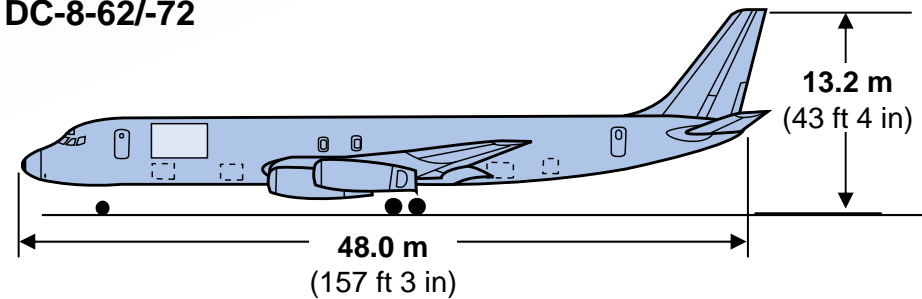

DC-8-54/-55

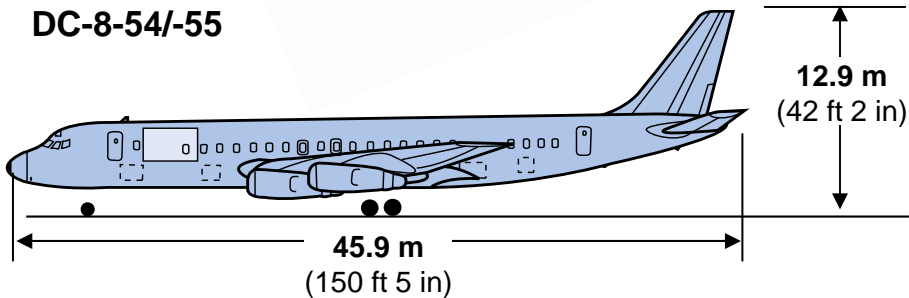

DC-8-63/-73 Freighters

Turnaround servicing arrangement

StartupBoeing

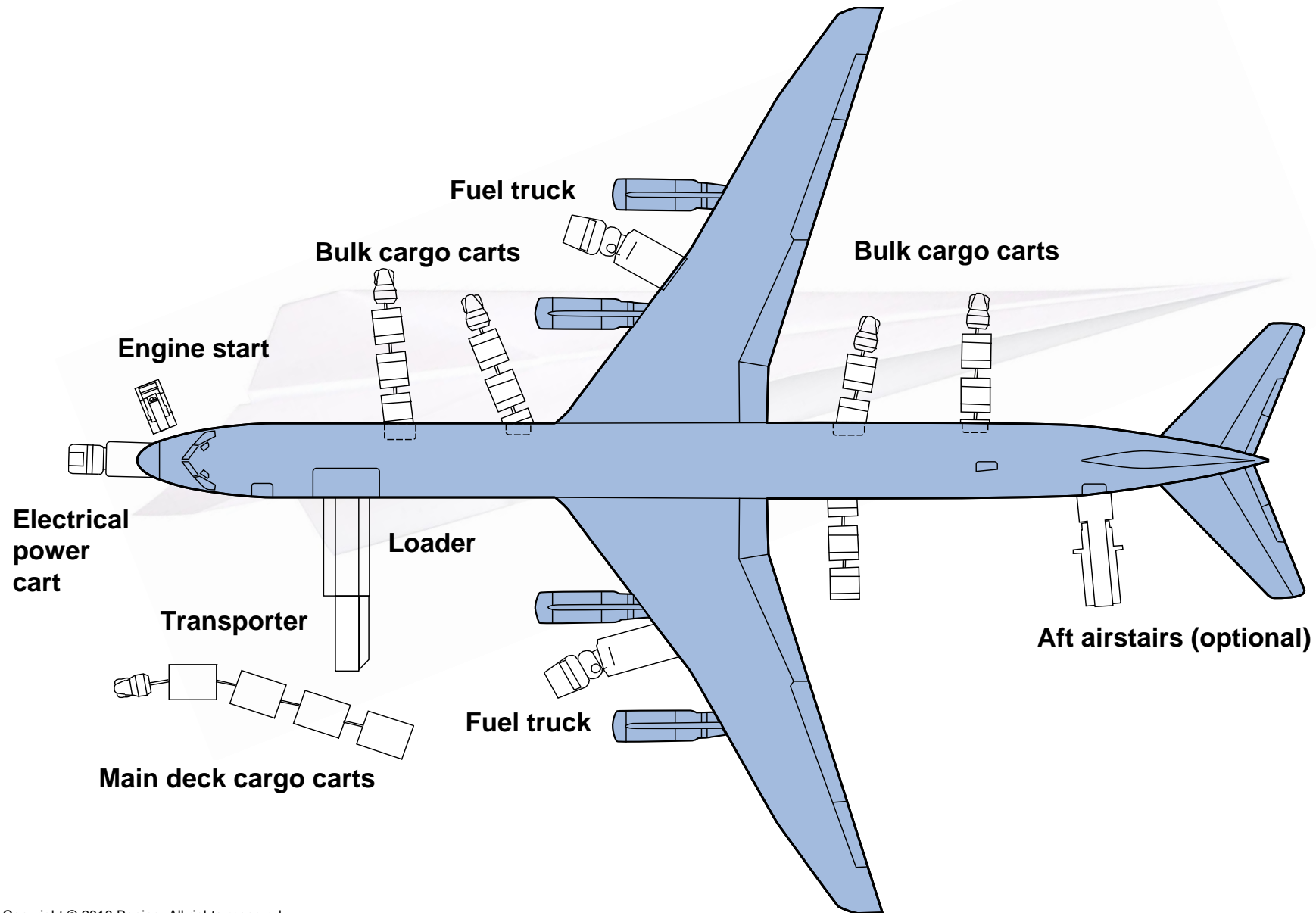

DC-8 Freighters

Main deck cargo arrangements

StartupBoeing

DC-8-50 Series Freighters

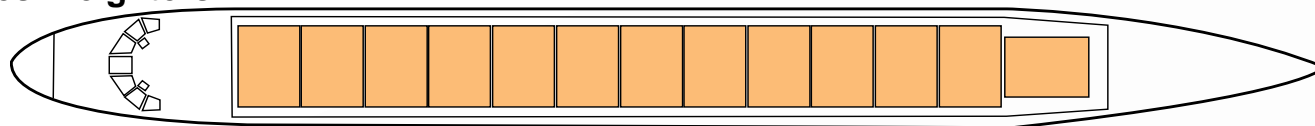

13 containers, 88 x 125-in (2.2 x 3.2-m)
Volume, 162.0 m³ (5,720 ft³)

DC-8-62/-72 Freighters

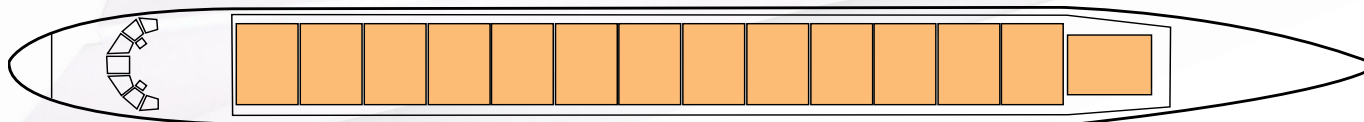

14 containers, 88 x 125-in (2.2 x 3.2-m)
Volume, 174.4 m³ (6,160 ft³)

DC-8-61/-63/-71/-73 Freighters

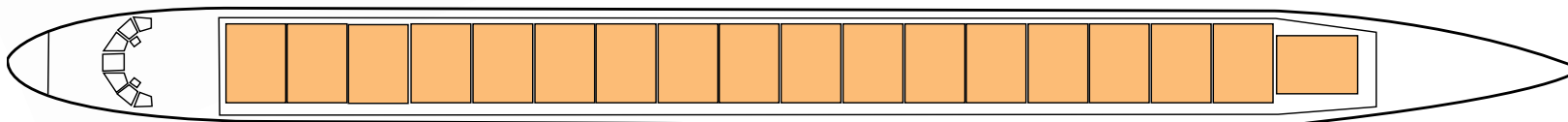

18 containers, 88 x 125-in (2.2 x 3.2-m)
Volume, 224.3 m³ (7,920 ft³)

DC-8 Freighters

Cross section

StartupBoeing

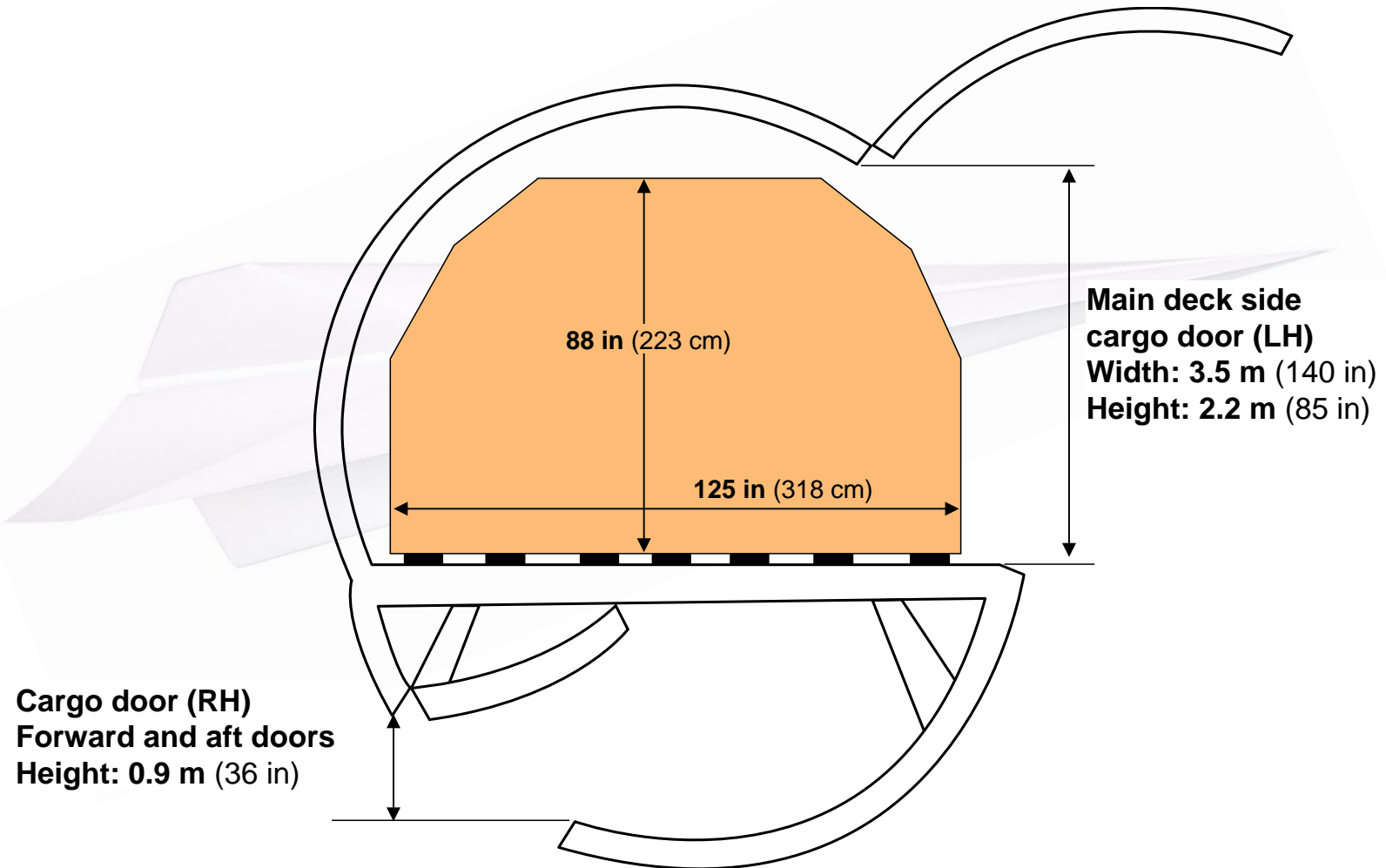

DC-8-54/-55 Freighters

Performance summary

StartupBoeing

Pratt & Whitney JT3D-3B engines

	DC-8-54AF	DC-8-54CF (cargo mode)	DC-8-55AF	DC-8-55CF (cargo mode)
Cargo capacity, m³ (ft³)				
Main deck, (13) 88- x 125-in (2.2 x 3.2-m) pallets or containers	162.0 (5,720)	162.0 (5,720)	162.0 (5,720)	162.0 (5,720)
Lower hold bulk	39.4 (1,390)	39.4 (1,390)	39.4 (1,390)	39.4 (1,390)
Total cargo volume	201.4 (7,110)	201.4 (7,110)	201.4 (7,110)	201.4 (7,110)
Maximum gross weight, kg (lb)				
Takeoff	142,880 (315,000)	142,880 (315,000)	147,420 (325,000)	147,420 (325,000)
Landing	108,860 (240,000)	108,860 (240,000)	108,860 (240,000)	108,860 (240,000)
Zero fuel	101,600 (224,000)	101,600 (224,000)	101,600 (224,000)	101,600 (224,000)
Structural payload (MZFW–OEW)	43,540 (96,000)	41,275 (91,000)	43,540 (96,000)	43,790 (96,550)
Fuel capacity, L (U.S. gal)	70,880 (18,725)	92,625 (24,470)	92,625 (24,470)	89,867 (23,741)
Design range (MZFW payload) nmi, (km)	2,250 (4,165)	2,350 (4,350)	2,650 (4,905)	2,600 (4,815)

DC-8-62 Freighters

Performance summary

StartupBoeing

Pratt & Whitney JT3D-3B engines

	DC-8-62AF	DC-8-62CF (cargo mode)
Cargo capacity, m³ (ft³)		
Main deck, (14) 88- x 125-in (2.2 x 3.2-m) pallets or containers	174.4 (6,160)	174.4 (6,160)
Lower hold bulk	45.7 (1,615)	45.7 (1,615)
Total cargo volume	220.1 (7,775)	220.1 (7,775)
Maximum gross weight, kg (lb)		
Takeoff	151,955 (335,000)	151,955 (335,000)
Landing	113,395 (250,000)	113,395 (250,000)
Zero fuel	104,320 (230,000)	104,320 (230,000)
Structural payload (MZFW–OEW)	42,635 (94,000)	39,915 (88,000)
Fuel capacity, L (U.S. gal)	94,635 (25,000)	94,635 (25,000)
Design range (MZFW payload) nmi, (km)	2,800 (5,185)	2,850 (5,275)

DC-8-61/-71 Freighters

Performance summary

StartupBoeing

*Pratt & Whitney JT3D-3B engines, CFM56-2C1 engines**

	DC-8-61CF (cargo mode)	DC-8-71CF
Cargo capacity, m³ (ft³)		
Main deck, (18) 88- x 125-in (2.2 x 3.2-m) pallets or containers	224.3(7,920)	224.3 (7,920)
Lower hold bulk	70.8(2,500)	70.8 (2,500)
Total cargo volume	295.1(10,420)	295.1 (10,420)
Maximum gross weight, kg (lb)		
Takeoff	148,775(328,000)	148,775 (328,000)
Landing	117,025(258,000)	117,025 (258,000)
Zero fuel	106,140(234,000)	106,140 (234,000)
Structural payload (MZFW–OEW)	39,005(86,000)	36,875 (81,300)
Fuel capacity, L (U.S. gal)	89,865(23,740)	89,865 (23,740)
Design range (MZFW payload) nmi, (km)	2,200(4,070)	2,800 (5,185)

*DC-8-71CF.

DC-8-63/-73 Freighters

Performance summary

StartupBoeing

Pratt & Whitney JT3D-7 engines, CFM56-2 engines*

	DC-8-63AF	DC-8-63CF (cargo mode)	DC-8-73AF	DC-8-73CF (cargo mode)
Cargo capacity, m³ (ft³)				
Main deck, (18) 88- x 125-in (2.2 x 3.2-m) pallets or containers	224.3 (7,920)	224.3 (7,920)	224.3 (7,920)	224.3 (7,920)
Lower hold bulk	70.8 (2,500)	70.8 (2,500)	70.8 (2,500)	70.8 (2,500)
Total cargo volume	295.1 (10,420)	295.1 (10,420)	295.1 (10,420)	295.1 (10,420)
Maximum gross weight, kg (lb)				
Takeoff	161,025 (355,000)	161,025 (355,000)	161,025 (355,000)	161,025 (355,000)
Landing	124,735 (275,000)	124,735 (275,000)	124,735 (275,000)	124,735 (275,000)
Zero fuel	118,385 (261,000)	118,385 (261,000)	118,385 (261,000)	118,385 (261,000)
Structural payload (MZFW–OEW)	52,615 (116,000)	49,440 (109,000)	50,710 (111,800)	47,535 (104,800)
Fuel capacity, L (U.S. gal)	94,635 (25,000)	94,635 (25,000)	94,635 (25,000)	94,635 (25,000)
Design range (MZFW payload) nmi, (km)	2,400 (4,440)	2,400 (4,440)	2,800 (5,185)	2,800 (5,185)

*DC-8-63F.

DC-8-54 Freighters

Payload-range capability

StartupBoeing

Pratt & Whitney JT3D-3B engines

Payload, 1,000 kg (1,000 lb)

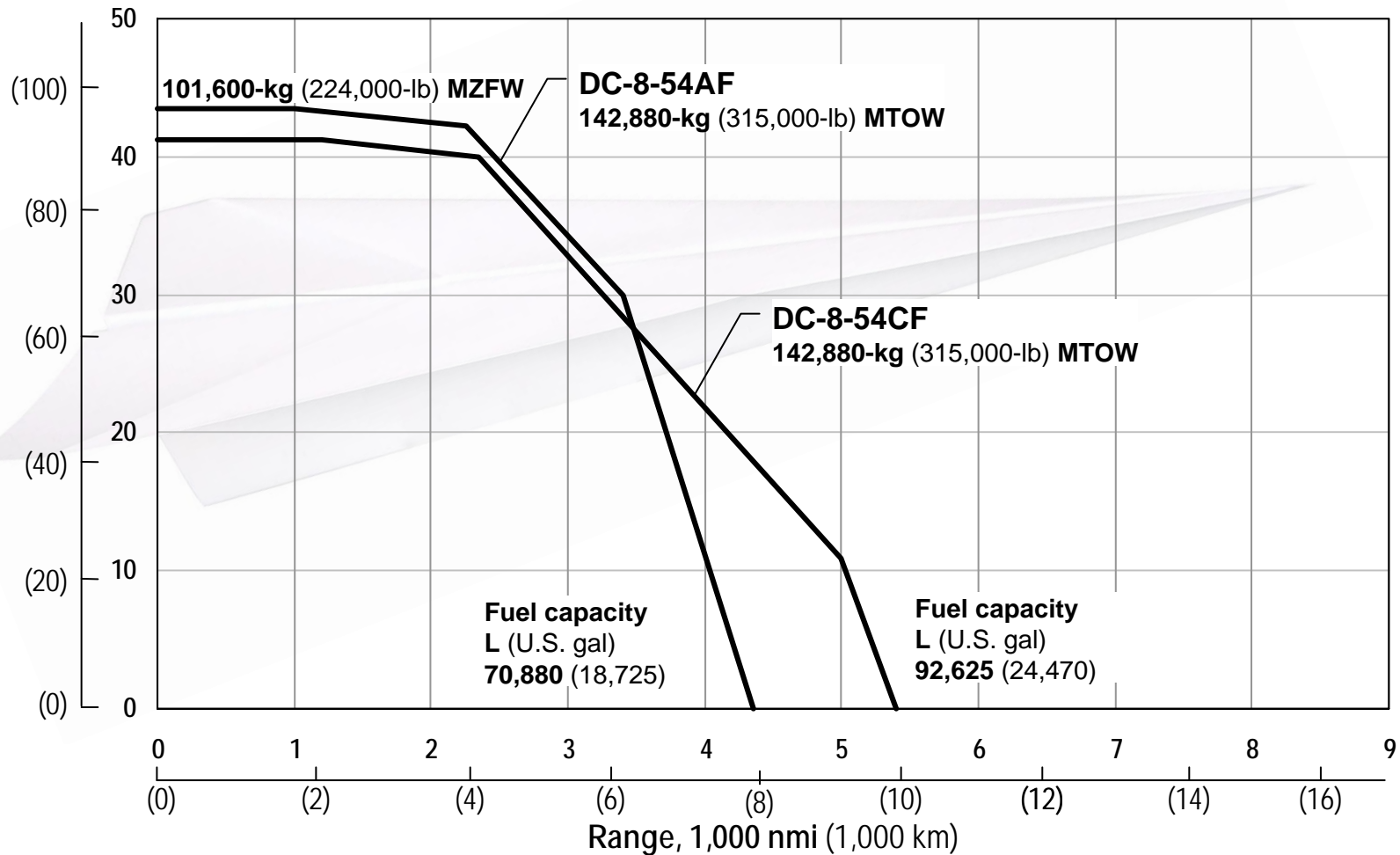

DC-8-55 Freighters

Payload-range capability

StartupBoeing

Pratt & Whitney JT3D-3B engines

Payload, 1,000 kg (1,000 lb)

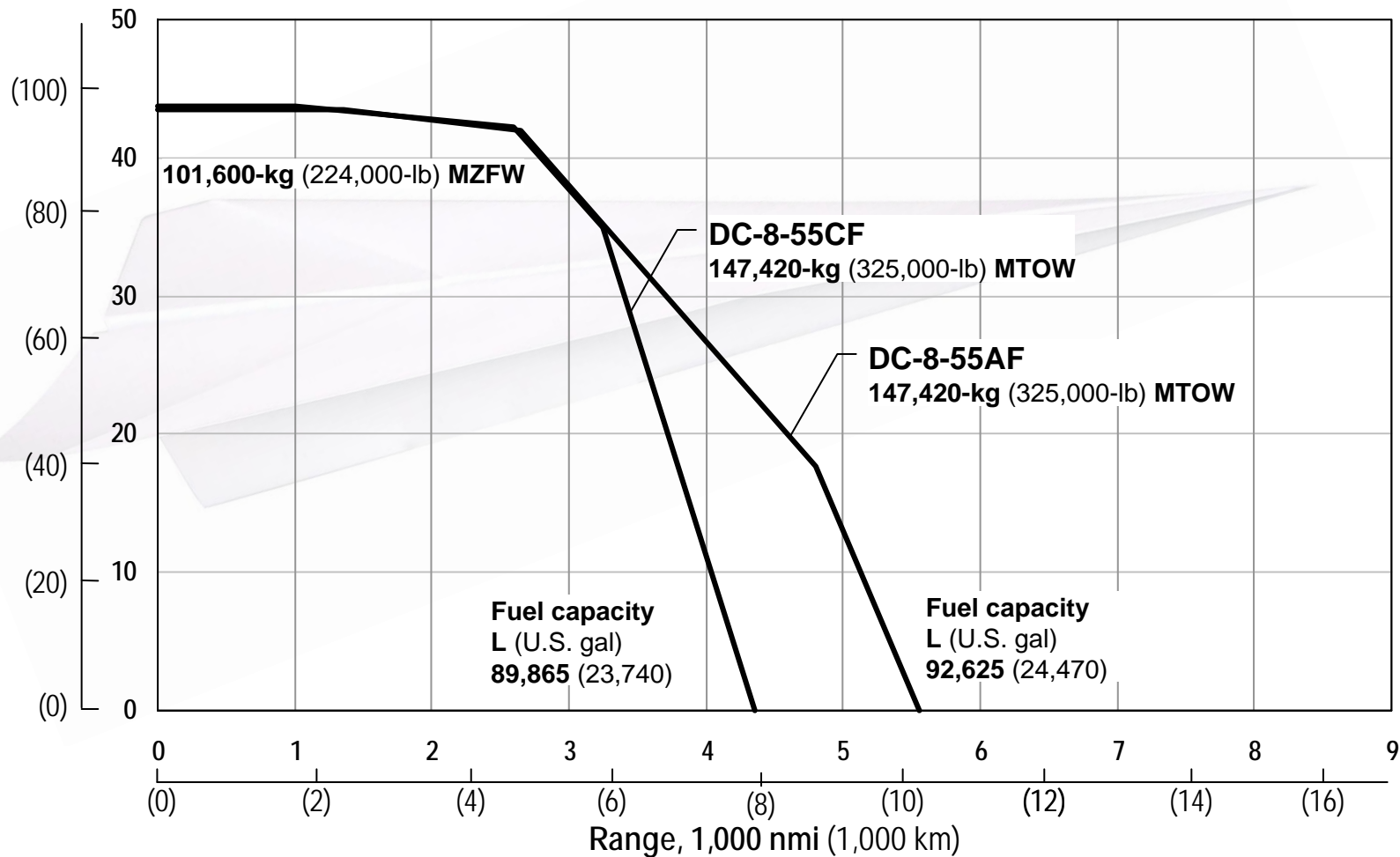

DC-8-62 Freighters

Payload-range capability

StartupBoeing

Pratt & Whitney JT3D-3B engines

Payload, 1,000 kg (1,000 lb)

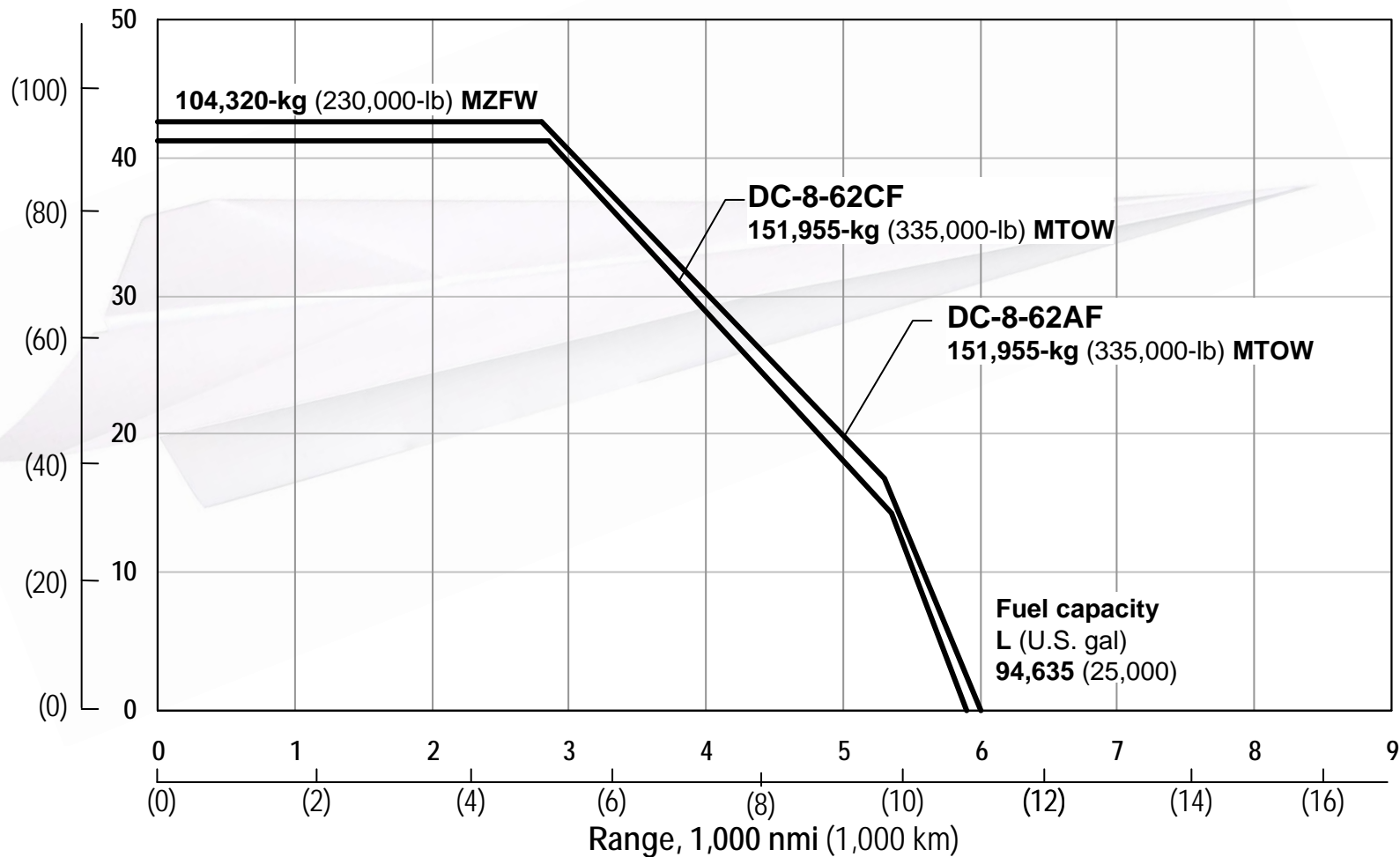

DC-8-61/-71 Freighters

Payload-range capability

StartupBoeing

*Pratt & Whitney JT3D-3B engines, CFM56-2C1 engines**
Payload, 1,000 kg (1,000 lb)

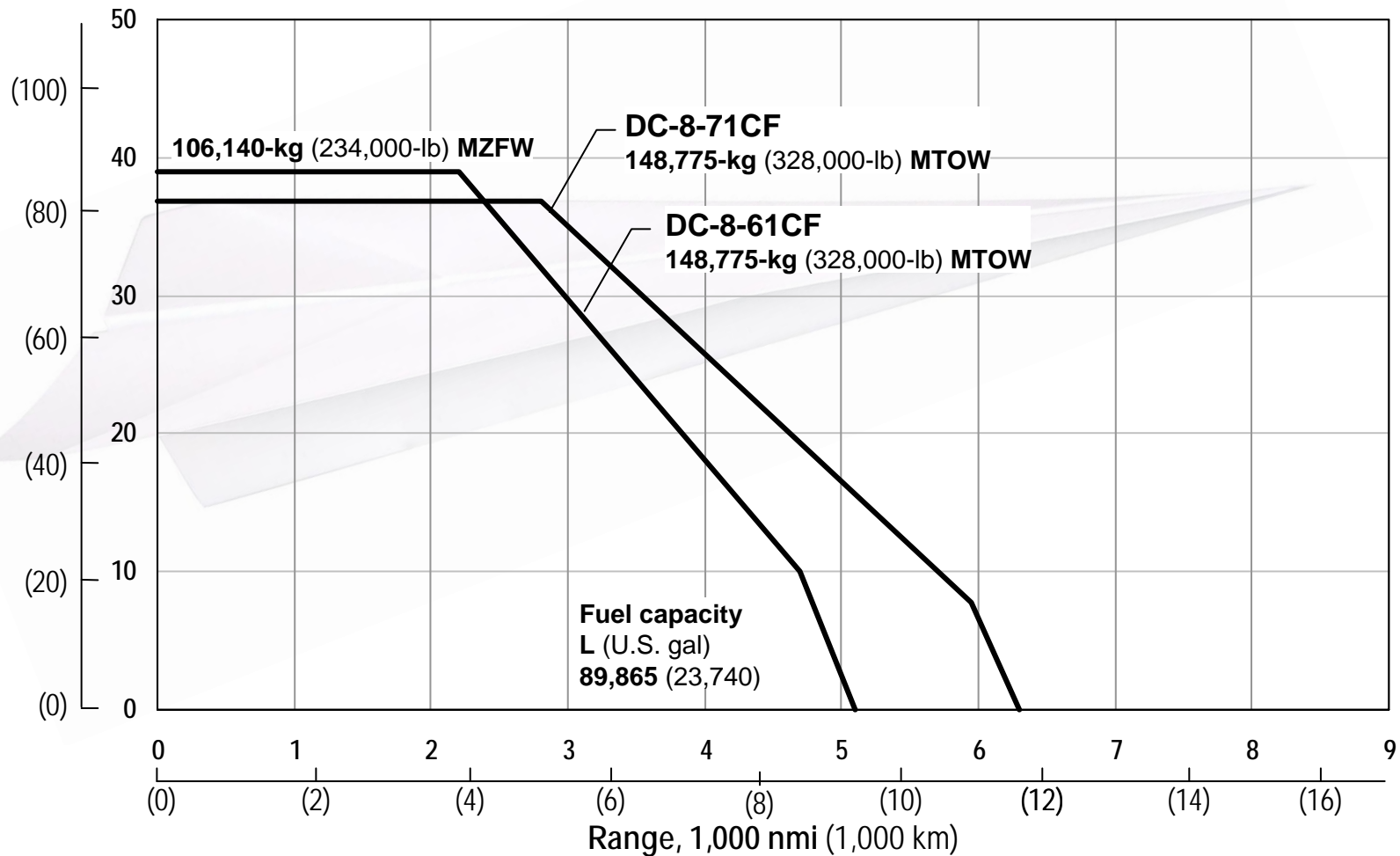

*DC-8-71CF.

DC-8-63 Freighters

Payload-range capability

StartupBoeing

Pratt & Whitney JT3D-7

Payload, 1,000 kg (1,000 lb)

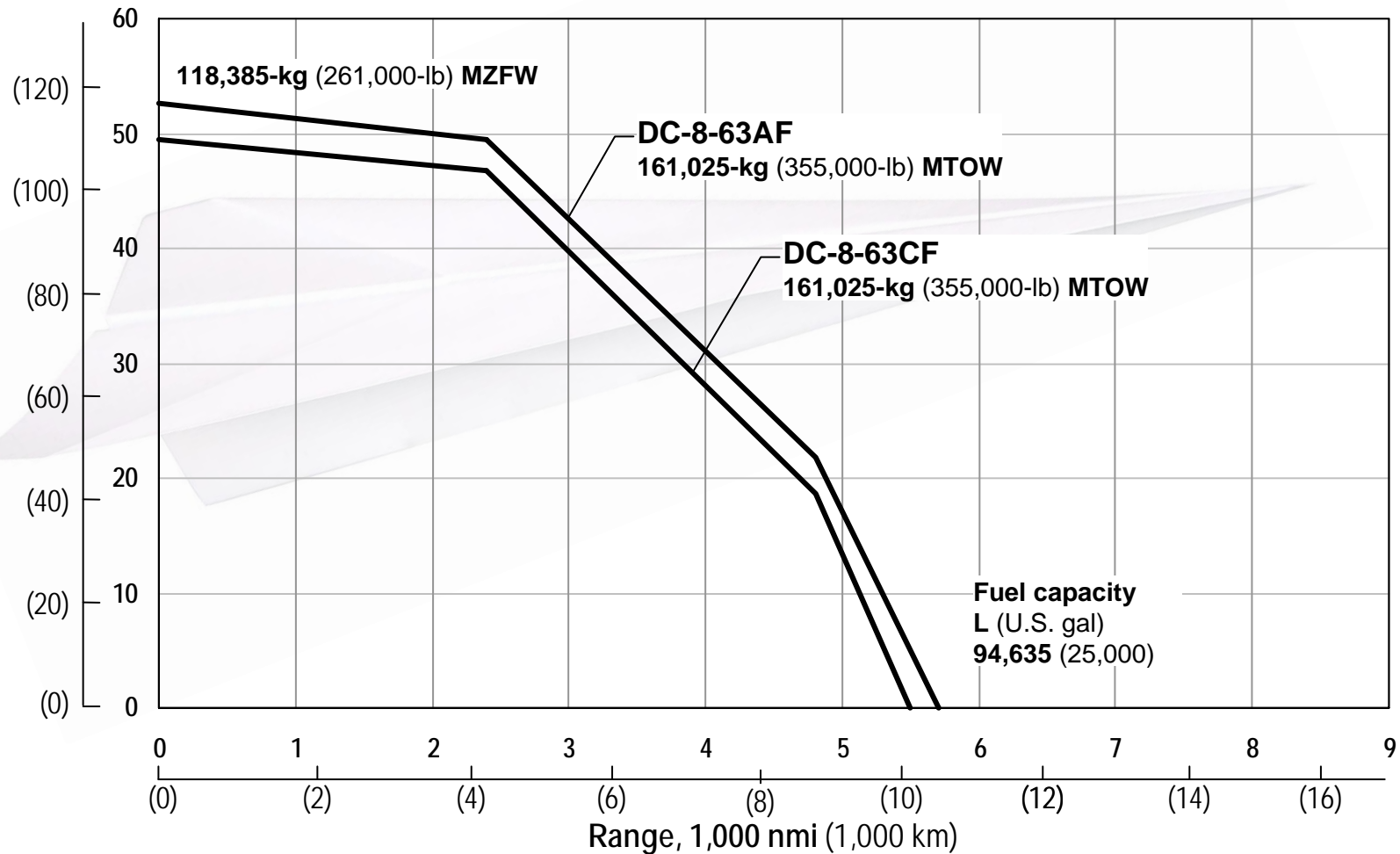

DC-8-73 Freighters

Payload-range capability

StartupBoeing

CFM56-2 engines

Payload, 1,000 kg (1,000 lb)

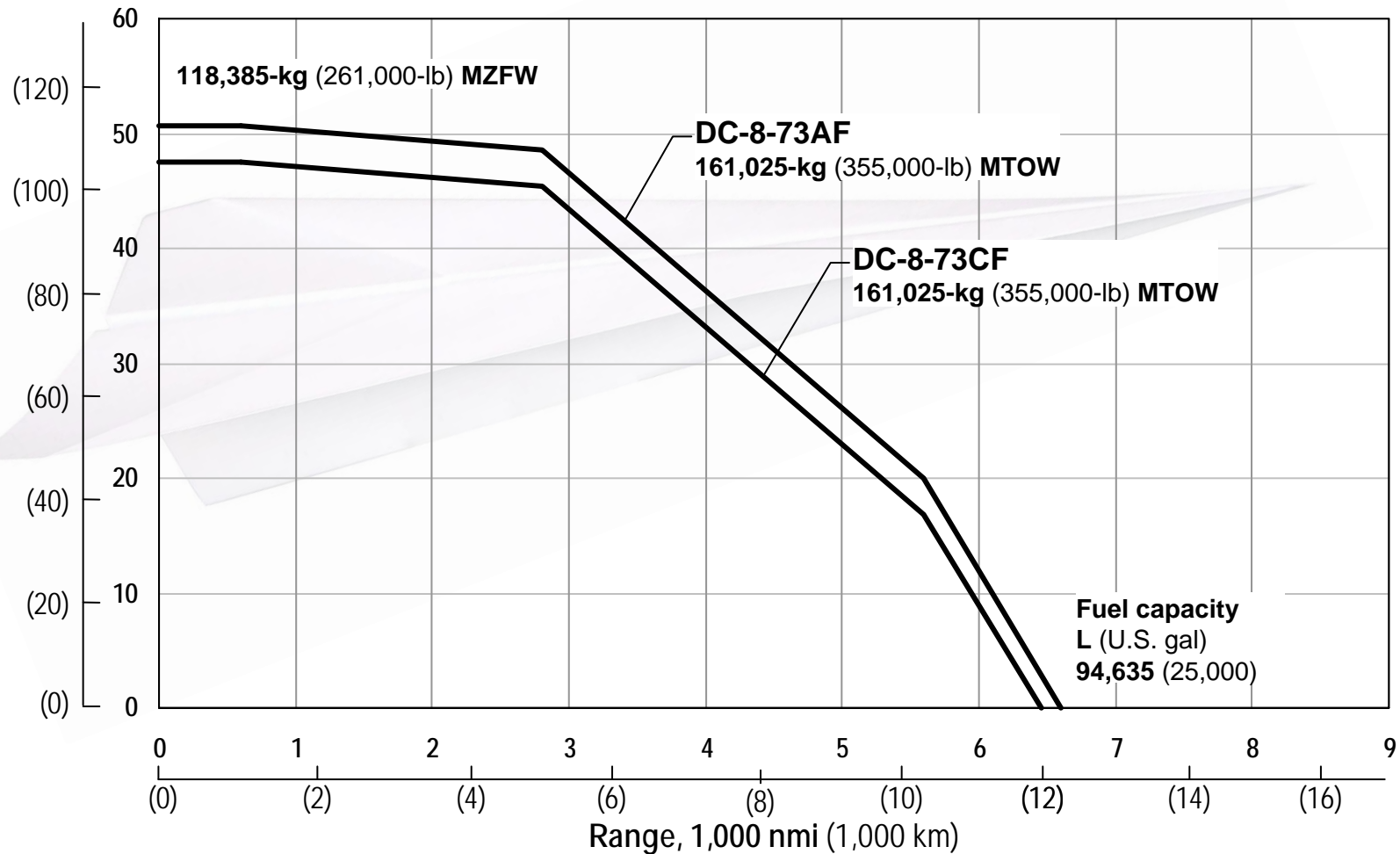

Payload-Range Capability

StartupBoeing

